

# PRODUKTÜBERSICHT

PRODUCT OVERVIEW



**Drehen**  
**turning**

**Fräsen**  
**milling**



# Drehen turning

Inhalt  
content

	<p><b>ULTRAMINI</b></p>	<p>Bohrungsbearbeitung ab Ø 0.2 mm</p> <p>Grooving, boring and profiling starting at Ø 0.2 mm</p>	<p><b>1</b></p>	
	<p><b>MINICUT</b></p>	<p>Bohrungsbearbeitung ab Ø 7.8 mm</p> <p>Grooving, boring and profiling starting at Ø 7.8 mm</p>	<p><b>118</b></p>	
	<p><b>SWISSLINE</b></p>	<p>Miniaturaußenbearbeitung, zweischneidig</p> <p>miniature external machining, two-cutting edges</p>	<p><b>182</b></p>	
	<p><b>STECHDREH- WERKZEUGE</b></p>	<p>SYSTEM DED: Einstecken dreischneidig SYSTEM ZTP: Einstecken zweischneidig</p> <p>system DED: grooving with three-cutting edges system ZTP: grooving with two-cutting edges</p>	<p><b>230</b></p>	
	<p><b>NUTSTOSSEN</b></p>	<p>Herstellung von Längsnuten Breite 2-20 mm und Innensechskant</p> <p>Broaching keyways in the range of 2-20 mm and hexagon socket</p>	<p><b>278</b></p>	



# Fräsen milling

Inhalt  
content

	<p><b>MIKROMILL</b></p>	<p>Nut- und Formzirkularfräsen drei- und vierschneidig, ab Ø 1.3 mm</p> <p>Groove milling by circular interpolation with three and four cutting edges, starting at Ø 1.3 mm</p>	<p><b>312</b></p>	
	<p><b>MINIMILL</b></p>	<p>Nut- und Formzirkularfräsen drei- und sechsschneidig, ab Ø 10 mm</p> <p>Groove milling by circular interpolation with three and six cutting edges, starting at Ø 10 mm</p>	<p><b>334</b></p>	
	<p><b>SYSTEM 500</b></p>	<p>Nut- und Formfräsen Nut- und Trennfräsen</p> <p>Groove milling by circular interpolation groove milling and slotting cutter</p>	<p><b>430</b></p>	
	<p><b>rotaline</b></p>	<p>Ausspindeln ab Ø 0.4 mm</p> <p>Precision boring starting at Ø 0.4 mm</p>	<p><b>460</b></p>	



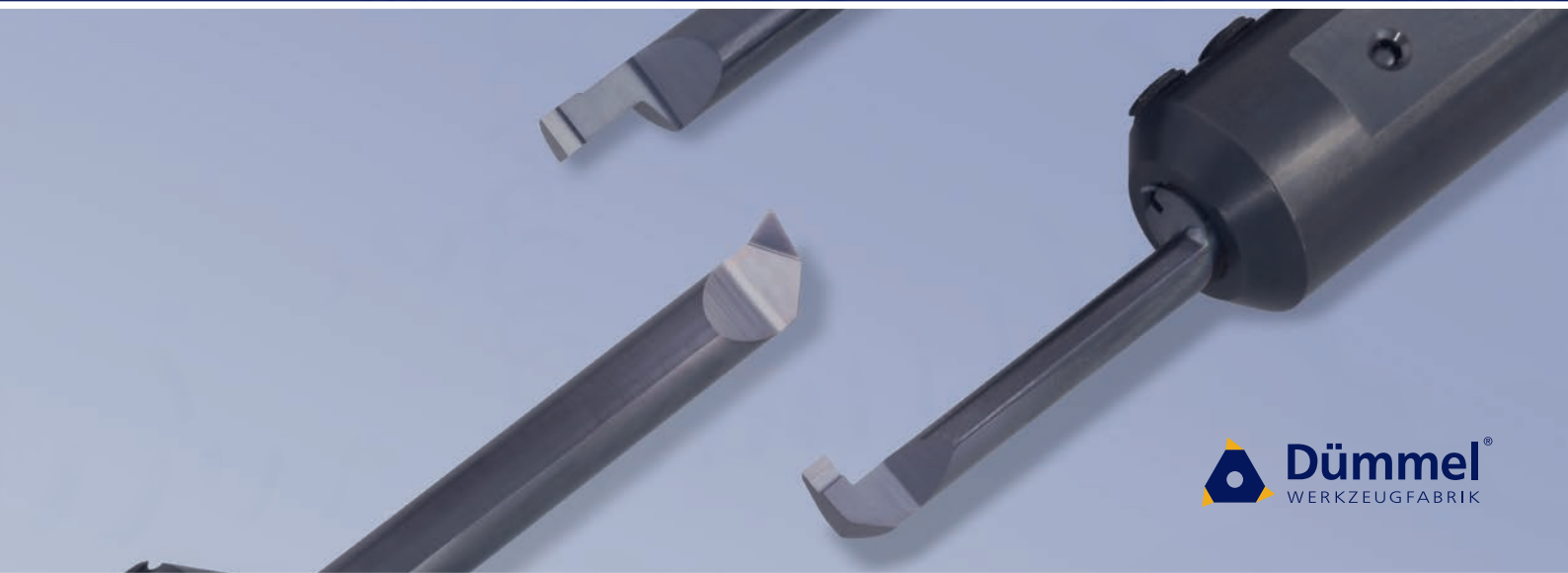

## ULTRAMINI



Bohrungsbearbeitung ab  $\varnothing$  0.2 mm

Grooving, boring and profiling  
starting at  $\varnothing$  0.2 mm



## ULTRAMINI

Bohrungsbearbeitung  
ab Ø 0.2 mm

grooving, boring and profiling  
starting at Ø 0.2 mm

## Übersicht

summary

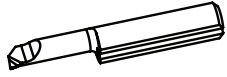

Allgemeine Beschreibung

general instructions

... 8



**Klemmhalter  
Rundschaft**

**toolholder  
straight shank**

**Maße  
dimensions**

**Seite  
page**

<b>Typ 645</b>	Klemmhalter	toolholder	Ø 12 - 28 D min. 0.2 - 5.0	... 11
<b>Typ 645.PT</b>	Klemmhalter, Premiumline mit verbesserter Kühlung	toolholder, Premiumline with improved cooling	Ø 12 - 28 D min. 0.2 - 5.0	... 12
<b>Typ 676</b>	Klemmhalter	toolholder	Ø 16 - 28 D min. 6.0 - 7.0	... 13
<b>Typ 676.PT</b>	Klemmhalter, Premiumline mit verbesserter Kühlung	toolholder, Premiumline with improved cooling	Ø 15.87 - 28 D min. 6.0 - 7.0	... 14
<b>Typ 687 / 681</b>	Klemmhalter	toolholder	Ø 16 - 20 / Ø 20 D min. 6.8 - 7.8 / D min. 7.8 - 10.5	... 15
<b>Typ 687.PT</b>	Klemmhalter, Premiumline mit verbesserter Kühlung	toolholder, Premiumline with improved cooling	Ø 16 - 20 D min. 6.8 - 7.8	... 16
<b>Typ 640 / 650 / 660 / 670 / 680</b>	Klemmhalter	toolholder	Ø 12 / Ø 12.7 D min. 0.2 - 7.8	... 17
<b>Typ 645.K</b>	Klemmhalter, ideal für Typ 520 und mit zentraler Kühlbohrung	toolholder, perfect for type 520 and with central cooling bore	Ø 12 - 20 D min. 0.2 - 5.0	... 18
<b>Typ 676.K</b>	Klemmhalter, ideal für Typ 520 und mit zentraler Kühlbohrung	toolholder, perfect for type 520 and with central cooling bore	Ø 16 - 20 D min. 6.0 - 7.0	... 19
<b>TYP UMST</b>	Klemmhalter, mit Hochdruckanschluss für Langdreher	toolholder, with high-pressure connection for Swiss type Machines	Ø 16 - 28 D min. 0.2 - 7.8	... 20
<b>Typ UM600H</b>	High-Performance-Klemmhalter, mit Kühlmittelanschluss	high-performance toolholder, with coolant connection	Ø 12 - 28 D min. 0.2 - 7.0	... 22

## ULTRAMINI

Bohrungsbearbeitung  
ab  $\varnothing$  0.2 mm

grooving, boring and profiling  
starting at  $\varnothing$  0.2 mm

## Übersicht

summary

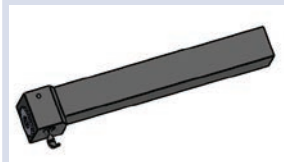

**Klemmhalter  
Quadratschaft und  
Rechteckschaft**

**toolholder  
square shank and  
rectangle shank**

**Maße  
dimensions**

**Seite  
page**



**Typ UM**

Klemmhalter,  
Quadratschaft

toolholder,  
square shank

ab / starting at  
10 x 10 mm  
D min. 0.2 - 7.0

... 25

**Typ .IK.UHCM**

Klemmhalter,  
Quadratschaft,  
mit Innenkühlung

toolholder,  
square shank,  
with internal cooling

ab / starting at  
12 x 12 mm  
D min. 0.2 - 7.0

... 26

**Typ .UM.18 / .UM.28**

Klemmhalter,  
Quadratschaft,  
mit Innenkühlung

toolholder,  
square shank,  
with internal cooling

10 x 10 mm  
D min. 0.2 - 7.0

... 27

**Typ .UM.18 / .UM.28**

Klemmhalter,  
Quadratschaft,  
mit Innenkühlung

toolholder,  
square shank,  
with internal cooling

12 x 12 mm  
D min. 0.2 - 7.0

... 28

**Typ TD0710**

Klemmhalter,  
Rechteckschaft  
für Tornos DECO 7/10

toolholder,  
rectangle shank  
for Tornos DECO 7/10

25 x 26 mm  
D min. 0.2 - 7.0

... 29



**Höhenverstellbarer  
Klemmhalter und Reduzierhülse  
für Rückseitenbearbeitung  
auf Langdrehautomaten**

**height adjustable toolholder  
and reduction bush  
for rear end machining  
on Swiss type lathes**

**Maße  
dimensions**

**Seite  
page**

**Typ UMHV**

Höhenverstellbarer  
Klemmhalter und  
Reduzierhülse

height adjustable  
toolholder and  
reduction bush

D min.  
ab 0.2 /  
starting at 0.2

... 30



## ULTRAMINI

Bohrungsbearbeitung  
ab  $\varnothing$  0.2 mm

grooving, boring and profiling  
starting at  $\varnothing$  0.2 mm

## Übersicht

summary

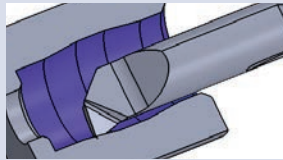

**Schneideinsätze**  
Ausdrehen und Kopieren

**inserts**  
boring and profiling

**Maße**  
dimensions

**Seite**  
page

<b>Typ 050</b>	Ausdrehen und Kopieren	boring and profiling	D min. 0.2 - 9.8	... 32
<b>Superfinish Typ F050</b>	Superfinish Ausdrehen für perfekte Oberflächen	Superfinish boring for perfect surface quality	D min. 4.0 - 6.8	... 37
<b>Typ 050.20</b>	Ausdrehen und Kopieren mit Geometrie 20° / 20°	boring and profiling with geometry 20° / 20°	D min. 2.0 - 5.0	... 38
<b>Typ 053</b>	Ausdrehen und Kopieren mit Eckenradius 0.03 mm	boring and profiling with corner radius 0.03 mm	D min. 2.8 - 4.0	... 39
<b>Typ 055</b>	Ausdrehen und Kopieren mit Eckenradius 0.05 mm	boring and profiling with corner radius 0.05 mm	D min. 2.0 - 6.0	... 40
<b>Typ 050....B</b>	Ausdrehen und Kopieren mit innerer Kühlmittelzufuhr	boring and profiling with through coolant	D min. 6.0 - 6.8	... 42
<b>Typ 050....C</b>	Ausdrehen und Kopieren mit Spantreppe für bessere Spankontrolle	boring and profiling with chipbreaker for better chipcontrol	D min. 2.0 - 6.8	... 43
<b>Mediline Typ M050</b>	Ausdrehen und Kopieren mit innerer Kühlmittelzufuhr und modifizierter Geometrie	boring and profiling with through coolant and modified profile	D min. 0.5 - 4.0	... 45
<b>Xtraline Typ X050</b>	Ausdrehen und Kopieren mit innerer Kühlmittelzufuhr, Spantreppe, extra stabile Ausführung	boring and profiling with through coolant, chipbreaker and extra solid construction	D min. 1.0 - 7.0	... 47
<b>Hardline Typ 050</b>	Ausdrehen und Kopieren, Hartbearbeitung bis 66 HRC	boring and profiling, hard machining up to 66 HRC	D min. 2.0 - 6.8	... 52
<b>Typ 050..../CBN</b>	Ausdrehen und Kopieren, für Hartbearbeitung	boring and profiling, for hard machining	D min. 2.8 - 6.8	... 54
<b>Typ 047</b>	Ausdrehen und Kopieren mit Geometrie 47° / 8°	boring and profiling with geometry 47° / 8°	D min. 2.0 - 6.0	... 55
<b>Typ 090</b>	Ausdrehen und Kopieren mit Geometrie 20° / 90°	boring and profiling with geometry 20° / 90°	D min. 2.8 - 5.0	... 56

## ULTRAMINI

Bohrungsbearbeitung  
ab  $\varnothing$  0.2 mm

grooving, boring and profiling  
starting at  $\varnothing$  0.2 mm

## Übersicht

summary

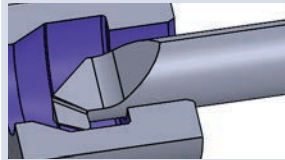

**Schneideinsätze  
Rückwärtsdrehen**

**inserts  
backboring**

**Maße  
dimensions**

**Seite  
page**

**Typ 080**

Rückwärtsdrehen

backboring

D min. 3.0 - 7.0

... 57

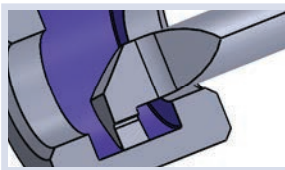

**Schneideinsätze  
Stechdrehen**

**inserts  
grooving**

**Maße  
dimensions**

**Seite  
page**

**Typ 001 / 0015**

Stechdrehen

grooving

D min. 1.0 / 1.5  
t max. 0.2 / 0.4

... 59

**Typ 002**

Stechdrehen

grooving

D min. 2.0  
t max. 0.4

... 60

**Typ 003**

Stechdrehen

grooving

D min. 3.0  
t max. 0.6

... 61

**Typ 004**

Stechdrehen

grooving

D min. 4.0  
t max. 0.8

... 62

**Typ 004M**

Stechdrehen  
mit Eckenradius

grooving  
with corner radius

D min. 4  
t max. 0.8

... 63

**Typ 005**

Stechdrehen

grooving

D min. 5  
t max. 1.0

... 64

**Typ 005M**

Stechdrehen  
mit Eckenradius

grooving  
with corner radius

D min. 5  
t max. 1.0

... 66

**Typ 006**

Stechdrehen

grooving

D min. 6  
t max. 1.8

... 68

**Typ 006M**

Stechdrehen  
mit Eckenradius

grooving  
with corner radius

D min. 6  
t max. 1.8

... 70

**Typ 007**

Stechdrehen

grooving

D min. 6.8  
t max. 2.5

... 72

**Typ 007M**

Stechdrehen  
mit Eckenradius

grooving  
with corner radius

D min. 6.8  
t max. 2.5

... 74

**Typ 008M**

Stechdrehen  
mit Eckenradius

grooving  
with corner radius

D min. 7.8  
t max. 3.0

... 76

↳ ...

## ULTRAMINI

Bohrungsbearbeitung  
ab  $\varnothing$  0.2 mm

grooving, boring and profiling  
starting at  $\varnothing$  0.2 mm

## Übersicht

summary

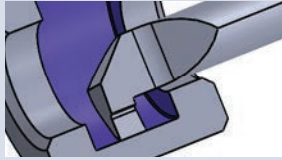

### Schneideinsätze Stechdrehen

### inserts grooving

### Maße dimensions

### Seite page

... ↴

<b>Typ 10M</b>	Stechdrehen mit Eckenradius und innerer Kühlmittelzufuhr	grooving with corner radius and through coolant	D min. 10.5 t max. 4.0	... 77
<b>Typ 004 / 005 / 006 / 007</b>	Stechdrehen und Kopieren mit Vollradius	grooving and profiling with full radius	D min. 4.0 R 0.5 - 1.0	... 78
<b>Typ 060</b>	Ausdrehen und Fasen	boring and chamfering	D min. 3.0 - 6.8	... 79
<b>Typ 070</b>	Vorstechen und Fasen	pregrooving and chamfering	D min. 4.0 - 6.0	... 80

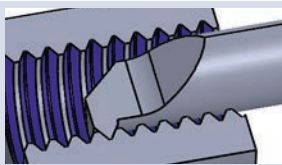

### Schneideinsätze Gewindedrehen, innen

### inserts threading, internal

### Maße dimensions

### Seite page

<b>Typ Gewindedrehen</b>	metrisches ISO-Gewinde, Teilprofil, innen	type threading, metric ISO-thread, partial profile, internal	D min. 1.56 - 7.0 P = 0.4 - 1.75	... 82
<b>Typ Gewindedrehen</b>	metrisches ISO-Gewinde, Vollprofil, innen	type threading, metric ISO-thread, full profile, internal	D min. 4.0 - 7.0 P = 0.5 - 1.5	... 84
<b>Typ Gewindedrehen</b>	Whitworth-Gewinde, Teilprofil, innen	type threading, Whitworth thread, partial profile, internal	D min. 4.8 - 7.0	... 85
<b>Typ Gewindedrehen</b>	Whitworth-Gewinde, Vollprofil, innen	type threading, Whitworth thread, full profile, internal	D min. 6.0	... 86
<b>Typ Gewindedrehen</b>	NPT-Gewinde, Teilprofil, innen	type threading, NPT thread, partial profile, internal	D min. 6.0	... 87
<b>Typ Gewindedrehen</b>	Trapezgewinde, Teilprofil, innen	type threading, trapezoidal thread, partial profile, internal	D min. 7.0 P = 2.0 - 3.0	... 88

## ULTRAMINI

Bohrungsbearbeitung  
ab  $\varnothing$  0.2 mm

grooving, boring and profiling  
starting at  $\varnothing$  0.2 mm

## Übersicht

summary

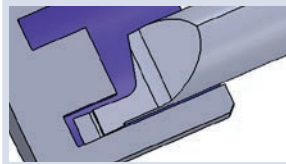

### Schneideinsätze Axialstechen

### inserts face grooving

### Maße dimensions

### Seite page



<b>Typ 510M</b>	Axialstechen mit Eckenradius	face grooving with corner radius	D min. 5.0 t max. 4.0	... 90
<b>Typ 610</b>	Axialstechen	face grooving	D min. 6.0 t max. 3.5	... 91
<b>Typ 610M</b>	Axialstechen mit Eckenradius	face grooving with corner radius	D min. 6.0 t max. 6.0	... 92
<b>Typ 610</b>	Axialstechen mit Vollradius	face grooving with full radius	D min. 6.0 t max. 6.0	... 93
<b>Typ 620</b>	Axialstechen am Zapfen vorbei	face grooving in pivots	D min. 6.0 t max. 6.0	... 94
<b>Typ 620M</b>	Axialstechen am Zapfen vorbei, mit Eckenradius	face grooving in pivots, with corner radius	D min. 6.0 t max. 6.0	... 95
<b>Typ 010</b>	Axialstechen	face grooving	D min. 6.0 t max. 3.5	... 96
<b>Typ 010M</b>	Axialstechen mit Eckenradius	face grooving with corner radius	D min. 8.0 t max. 6.0	... 98
<b>Typ 010</b>	Axialstechen mit Vollradius	face grooving with full radius	D min. 8.0 t max. 6.0	... 100
<b>Typ 015</b>	Axialstechen	face grooving	D min. 8.0 t max. 3.0	... 101
<b>Typ 015M</b>	Axialstechen mit Eckenradius	face grooving with corner radius	D min. 8.0 t max. 3.0	... 102
<b>Typ 012 / 016</b>	Axialstechen mit Eckenradius und doppeltem Kühlkanal	face grooving with corner radius and double internal cooling	D min. 12.0 t max. 2.0	... 103
<b>Typ 020</b>	Axialstechen mit Eckenradius und doppeltem Kühlkanal	face grooving with corner radius and double internal cooling	D min. 20.0 t max. 4.0	... 104
<b>Typ 520</b>	Fasen	chamfering	D min. 1.0 t max. 4.0	... 105

## ULTRAMINI

Bohrungsbearbeitung  
ab Ø 0.2 mm

grooving, boring and profiling  
starting at Ø 0.2 mm

## Übersicht

summary



### Sets Ultramini

#### Halter und Schneiden (Rechte Ausführung)

### sets Ultramini

#### toolholder and inserts (righthand version)

### Maße dimensions

### Seite page

#### SET.1

- Ausdrehen und Kopieren
- Ausdrehen und Fasen
- Stechdrehen

- boring and profiling
- boring and chamfering
- grooving

... 106

#### SET.2

- Stechdrehen

- grooving

... 106

#### SET.3

- Ausdrehen und Kopieren

- boring and profiling

... 107

#### SET.6R

- Axialstechen

- face grooving

... 107

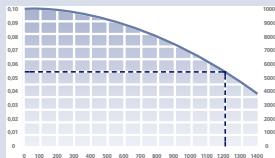

### Technische Hinweise

### Technical Instructions

### Seite page

Grundsätzliche Informationen zum  
Werkzeugprogramm Ultramini

Basic informations about the tool  
program Ultramini

... 108

Allgemeine Informationen zum  
Gewindeschneiden

General informations about threading

... 109

Hartmetallsorten und Beschichtungen

carbide grades and coatings

... 111

Schnittdaten

cutting data

... 113

## ULTRAMINI

Bohrungsbearbeitung  
ab  $\varnothing$  0.2 mm

grooving, boring and profiling  
starting at  $\varnothing$  0.2 mm

## Allgemeine Beschreibung

general instruction

### Ultramini:

Das überlegene System in der Mini-Bohrungsbearbeitung mit über 1000 Schneideinsätzen!

### Ultramini:

The superior system in the world of miniature machining with over 1000 different inserts!

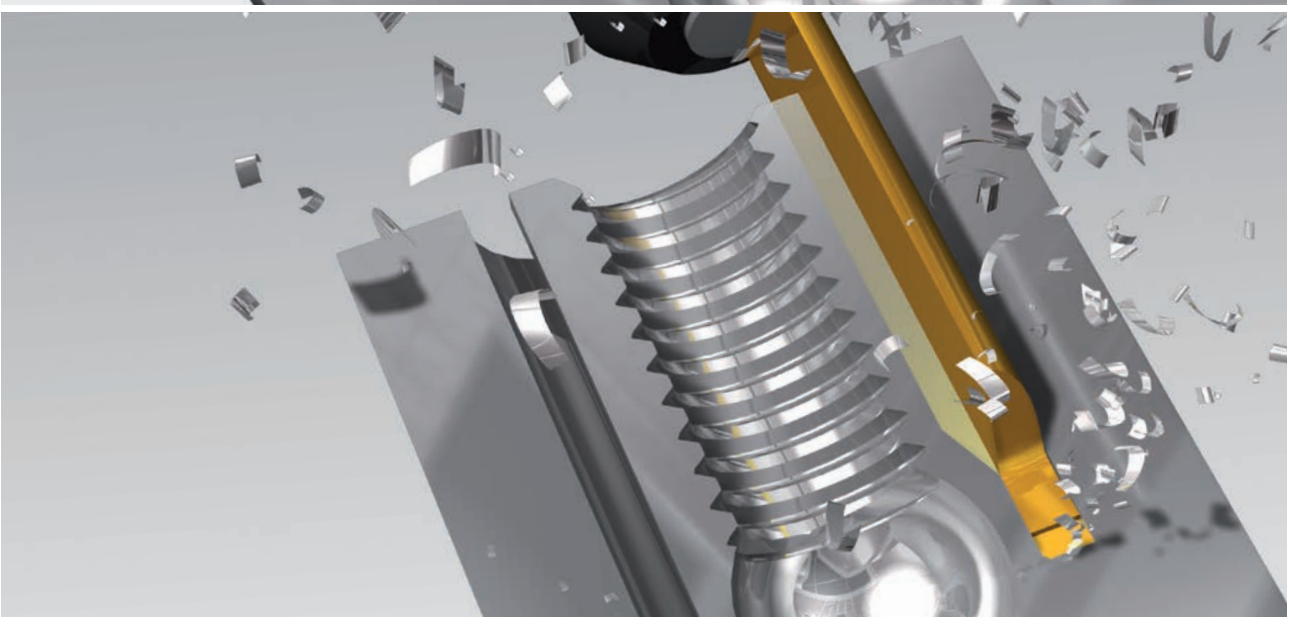
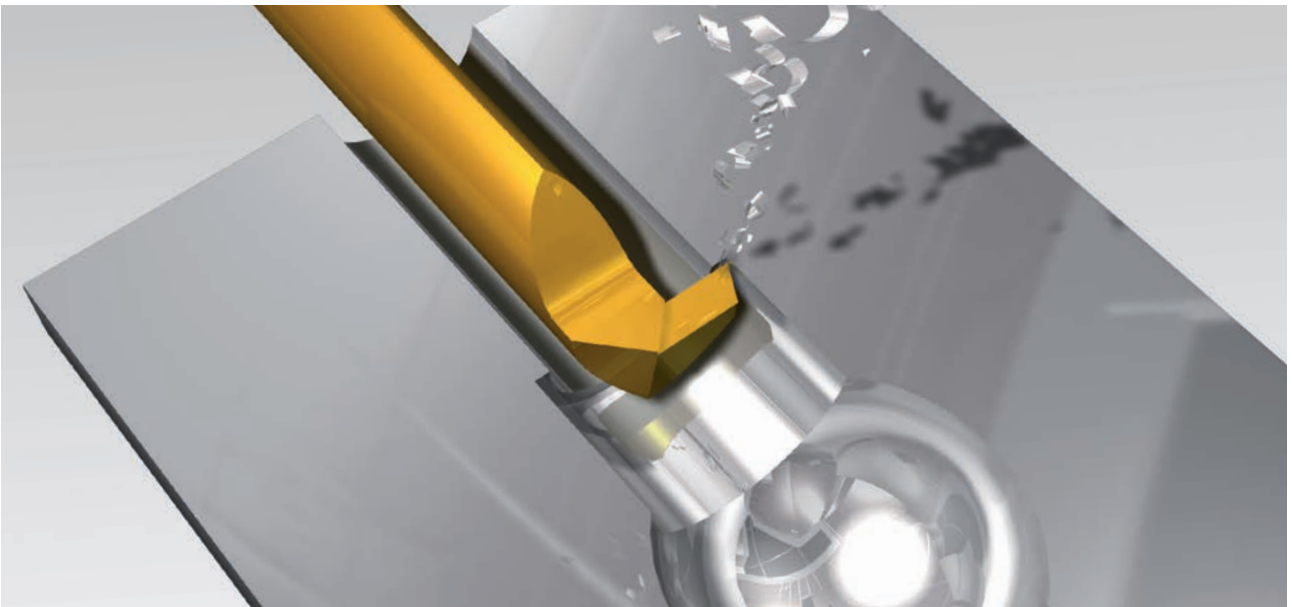

## ULTRAMINI

Bohrungsbearbeitung  
ab  $\varnothing 0.2 \text{ mm}$

grooving, boring and profiling  
starting at  $\varnothing 0.2 \text{ mm}$

## Allgemeine Beschreibung

Superfinish, Mediline, Xtraline und Hardline

general instruction  
Superfinish, Mediline, Xtraline and Hardline



### Superfinish Typ F050

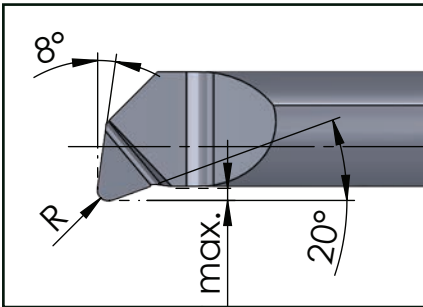

- Großer Eckenradius für hohe Oberflächenqualität
- Sonderhartmetall für einen stabilen und schwingungsarmen Aufbau
- Optimierte Beschichtung für eine geringe Rauhtiefe in der Bohrung
- Bei Einsatz im PT-Halter verbesserte Kühlung
- Big corner radius for high surface quality
- Premium carbide for a strong and low-vibration construction
- Optimized coating causes extremely low surface roughness in the bore
- Better cooling by using PT-toolholder

### Mediline Typ M050

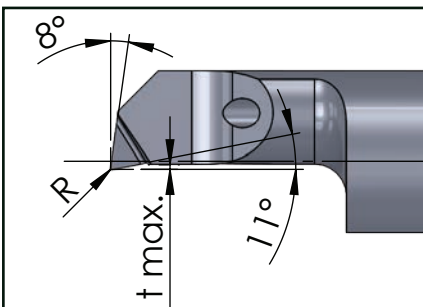

- Modifizierte Geometrie speziell für Materialien aus der Medizintechnik
- Innere Kühlmittelzufuhr
- Reduziertes t max. für höhere Stabilität
- Ausgezeichnete Oberflächenqualität der Schneide
- Eckenradius verspricht längere Standzeit und bessere Oberflächenqualität
- Modified geometry specifically designed for materials of medical technology
- Coolant delivered thru the tool
- Reduced t max. for higher stability
- Superior grinding surface quality
- Corner radius provides longer tool life and better surface finishes

## ULTRAMINI

Bohrungsbearbeitung  
ab  $\varnothing 0.2 \text{ mm}$

grooving, boring and profiling  
starting at  $\varnothing 0.2 \text{ mm}$

## Allgemeine Beschreibung

Superfinish, Mediline, Xtraline und Hardline

general instruction  
Superfinish, Mediline, Xtraline and Hardline

### Xtraline Typ X050

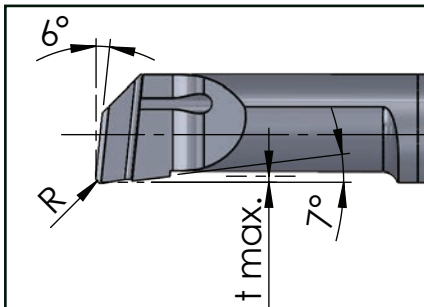

- Modifizierte Geometrie speziell für Nickel- und Chromlegierungen
- Innere Kühlmittelzufuhr
- Position der Kühlmittelzufuhr optimiert für beste Stabilität
- Reduziertes t max. für höhere Stabilität
- Variabler Eckenradius verspricht längere Standzeit und bessere Oberflächenqualität
- Spantreppe reduziert Schneidkräfte und ermöglicht höhere Schnittgeschwindigkeiten
- Modified geometry specifically designed for Nickel and Chrome based alloys
- Coolant delivered thru the tool
- Coolant hole location optimized for greatest tool rigidity
- Reduced t max. for higher stability
- Various corner radius provides for longer tool life and better surface finishes
- Chip breaker reduces cutting forces and provides for higher cutting feed

### Hardline Typ 050

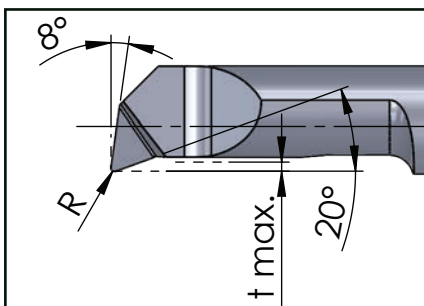

- Wirtschaftlicher als CBN
- Bis 66 HRC einsetzbar
- Optimal für dünnwandige Materialien
- Universell einsetzbar
- Scharfe Schneide
- Nur mit Kühlung arbeiten
- More economical than CBN
- Machine up to HRC 66
- Perfect for thin wall materials
- Very universal
- Sharp insert
- Don't use without cooling



**ULTRAMINI**

Bohrungsbearbeitung  
ab Ø 0.2 mm

grooving, boring and profiling  
starting at Ø 0.2 mm

**Typ 645**

Klemmhalter

toolholder

ab Ø 12 - 28 mm  
für Schneideinsatz mit  
D min. 0.2 - 5.0 mm

starting at Ø 12 - 28 mm  
for insert with  
D min. 0.2 - 5.0 mm

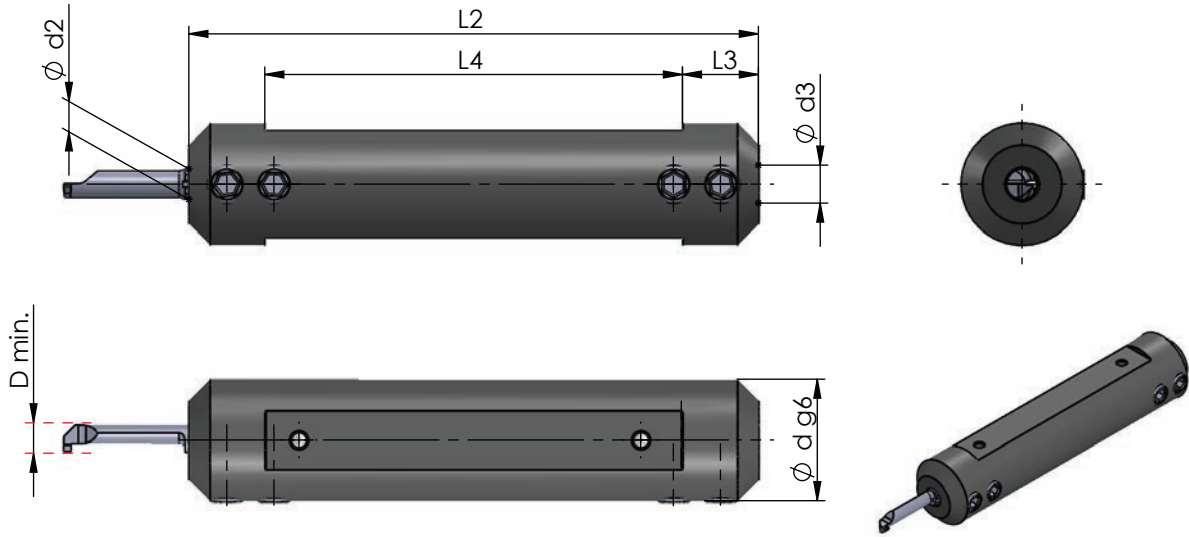

Klemmhalter für rechte und linke  
Schneideinsätze einsetzbar

toolholder for right and left  
inserts usable

Abmessungen in mm

dimensions in mm

Bestellnummer part number	Ø d g6			Spannschraube screw	Schraubenschlüssel wrench	Anzugs- drehmoment torque	Ø d2		Ø d h6	
	Ø d (inch)	L2	L3				L4	Ø d h6 Schneideinsatz insert	Ø d h6 Schneideinsatz insert	
645.0012-D	12		75	10	55	110.640	111.645	1.2 Nm	4	5
645.0016-D	16		75	10	55	110.645	111.645	1.2 Nm	4	5
645.0018-D	18		90	10	70	110.645	111.645	1.2 Nm	4	5
645.001905-D	19.05	3/4"	90	10	70	110.645	111.645	1.2 Nm	4	5
645.0020-D	20		90	10	70	110.650	111.645	1.2 Nm	4	5
645.0022-D	22		90	10	70	110.650	111.645	1.2 Nm	4	5
645.0025-D	25		95	10	75	110.650	111.645	1.2 Nm	4	5
645.00254-D	25.4	1"	95	10	75	110.650	111.645	1.2 Nm	4	5
645.0028-D	28		95	10	75	110.650	111.645	1.2 Nm	4	5

Bestellbeispiel:  
645.0012-D



# ULTRAMINI

Bohrungsbearbeitung  
ab Ø 0.2 mm

grooving, boring and profiling  
starting at Ø 0.2 mm

# Typ 645.PT

Klemmhalter,  
Premiumline mit  
verbesserter Kühlung

toolholder,  
Premiumline with  
improved cooling

ab Ø 12 - 28 mm  
für Schneideinsatz mit  
D min. 0.2 - 5.0 mm

starting at Ø 12 - 28 mm  
for insert with  
D min. 0.2 - 5.0 mm

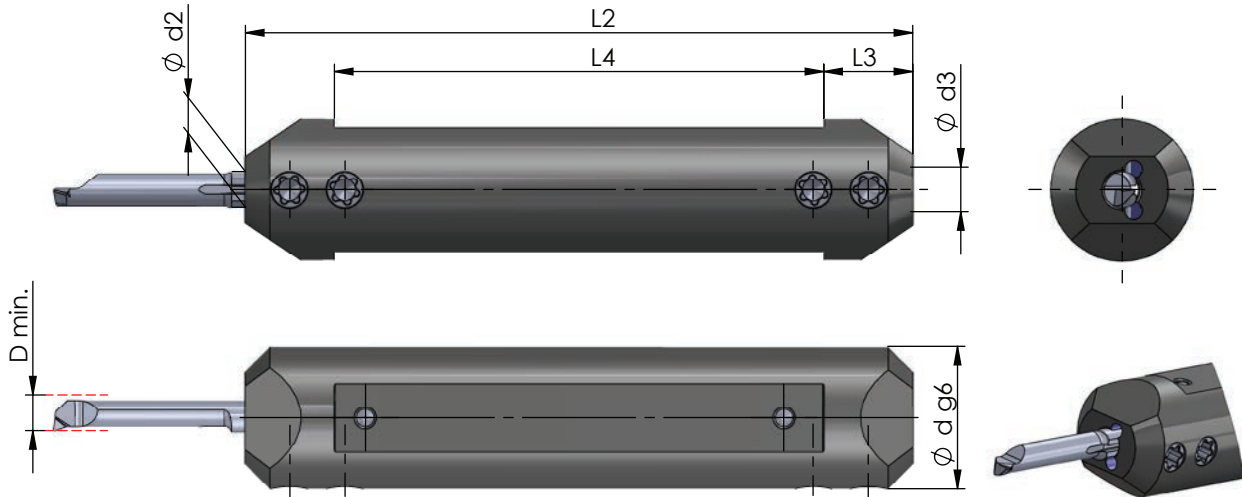

Klemmhalter für rechte und linke  
Schneideinsätze einsetzbar

toolholder for right and left  
inserts usable

Abmessungen in mm

dimensions in mm

Bestellnummer part number	Abmessungen in mm					dimensions in mm			dimensions in mm	
	Ø d g6	Ø d (inch)	L2	L3	L4	Spannschraube screw	Schraubenschlüssel wrench	Anzugs- drehmoment torque	Ø d2 ≤ Ø d h6 Schneideinsatz insert	Ø d3 ≤ Ø d h6 Schneideinsatz insert
645.PT12-D	12		75	10	55	PT12	T10F	1.2 Nm	4	5
645.PT127-D	12.7	1/2"	75	10	55	PT12	T10F	1.2 Nm	4	5
645.PT1587-D	15.87	5/8"	75	10	55	PT16	T10F	1.2 Nm	4	5
645.PT16-D	16		75	10	55	PT16	T10F	1.2 Nm	4	5
645.PT18-D	18		90	10	70	PT16	T10F	1.2 Nm	4	5
645.PT1905-D	19.05	3/4"	90	10	70	PT16	T10F	1.2 Nm	4	5
645.PT20-D	20		90	10	70	PT20	T10F	1.2 Nm	4	5
645.PT22-D	22		90	10	70	PT20	T10F	1.2 Nm	4	5
645.PT25-D	25		95	10	75	PT20	T10F	1.2 Nm	4	5
645.PT254-D	25.4	1"	95	10	75	PT20	T10F	1.2 Nm	4	5
645.PT28-D	28		95	10	75	PT20	T10F	1.2 Nm	4	5

Bestellbeispiel:  
645.PT12-D



**ULTRAMINI**

Bohrungsbearbeitung  
ab Ø 0.2 mm

grooving, boring and profiling  
starting at Ø 0.2 mm

**Typ 676**

Klemmhalter

toolholder

ab Ø 16 - 28 mm  
für Schneideinsatz mit  
D min. 6.0 - 7.0 mm

starting at Ø 16 - 28 mm  
for insert with  
D min. 6.0 - 7.0 mm

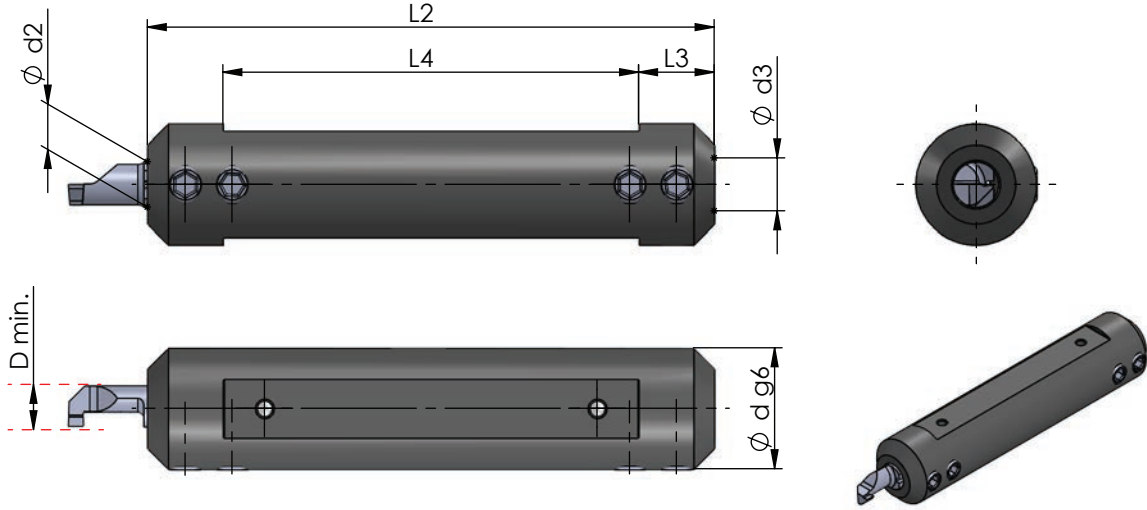

Klemmhalter für rechte und linke  
Schneideinsätze einsetzbar

toolholder for right and left  
inserts usable

Abmessungen in mm

dimensions in mm

Bestellnummer part number	Abmessungen in mm			Abmessungen in inch		Spannschraube screw	Schraubenschlüssel wrench	Anzugs- drehmoment torque	Schneideinsatz insert	
	Ø d g6	Ø d (inch)	L2	L3	L4				Ø d2    Ø d h6	Ø d3    Ø d h6
676.0016-D	16		75	10	55	110.645	111.645	1.2 Nm	6	7
676.0018-D	18		90	10	70	110.645	111.645	1.2 Nm	6	7
676.001905-D	19.05	3/4"	90	10	70	110.645	111.645	1.2 Nm	6	7
676.0020-D	20		90	10	70	110.650	111.645	1.2 Nm	6	7
676.0022-D	22		90	10	70	110.650	111.645	1.2 Nm	6	7
676.0025-D	25		95	10	75	110.650	111.645	1.2 Nm	6	7
676.00254-D	25.4	1"	95	10	75	110.650	111.645	1.2 Nm	6	7
676.0028-D	28		95	10	75	110.650	111.645	1.2 Nm	6	7

Bestellbeispiel:  
676.0016-D



# ULTRAMINI

Bohrungsbearbeitung  
ab Ø 0.2 mm

grooving, boring and profiling  
starting at Ø 0.2 mm

# Typ 676.PT

Klemmhalter,  
Premiumline mit  
verbesserter Kühlung

toolholder,  
Premiumline with  
improved cooling

ab Ø 15.87 - 28 mm  
für Schneideinsatz mit  
D min. 6.0 - 7.0 mm

starting at Ø 15.87 - 28 mm  
for insert with  
D min. 6.0 - 7.0 mm

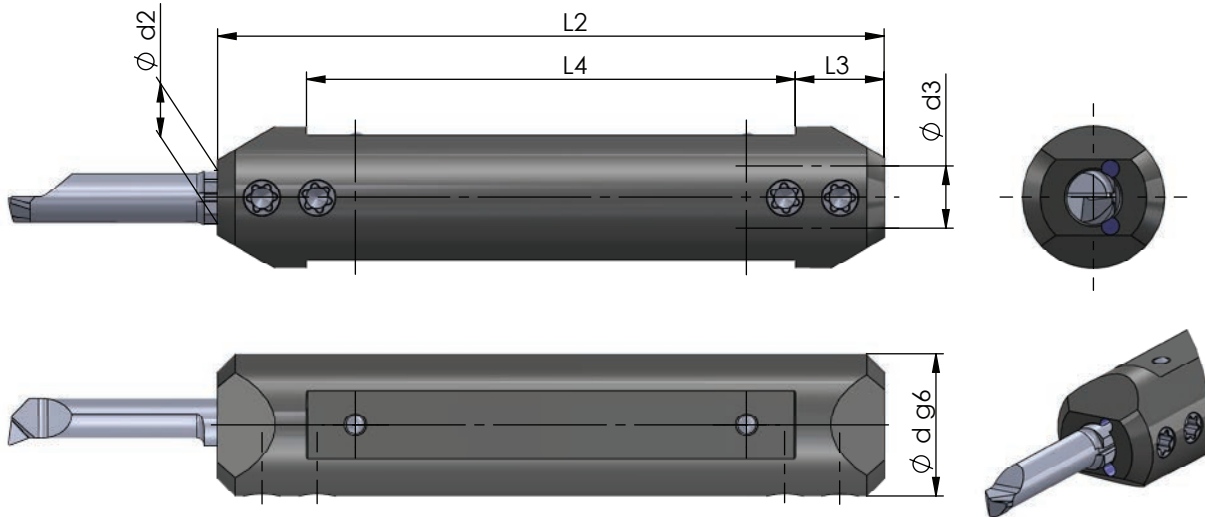

Klemmhalter für rechte und linke  
Schneideinsätze einsetzbar

toolholder for right and left  
inserts usable

Abmessungen in mm

dimensions in mm

Bestellnummer part number	Abmessungen in mm					dimensions in mm			dimensions in mm	
	Ø d g6	Ø d (inch)	L2	L3	L4	Spannschraube screw	Schraubenschlüssel wrench	Anzugs- drehmoment torque	Ø d2 ≤ Ø d h6 Schneideinsatz insert	Ø d3 ≤ Ø d h6 Schneideinsatz insert
676.PT1587-D	15.87	5/8"	75	10	55	PT16	T10F	1.2 Nm	6	7
676.PT16-D	16		75	10	55	PT16	T10F	1.2 Nm	6	7
676.PT18-D	18		90	10	70	PT16	T10F	1.2 Nm	6	7
676.PT1905-D	19.05	3/4"	90	10	70	PT16	T10F	1.2 Nm	6	7
676.PT20-D	20		90	10	70	PT20	T10F	1.2 Nm	6	7
676.PT22-D	22		90	10	70	PT20	T10F	1.2 Nm	6	7
676.PT25-D	25		95	10	75	PT20	T10F	1.2 Nm	6	7
676.PT254-D	25.4	1"	95	10	75	PT20	T10F	1.2 Nm	6	7
676.PT28-D	28		95	10	75	PT20	T10F	1.2 Nm	6	7

Bestellbeispiel:  
676.PT16-D



**ULTRAMINI**

Bohrungsbearbeitung  
ab Ø 0.2 mm

grooving, boring and profiling  
starting at Ø 0.2 mm

**Typ 687 / 681**

Klemmhalter

toolholder

ab Ø 16 - 20 mm  
für Schneideinsatz mit D min. 6.8 - 7.8 mm  
und D min. 7.8 - 10.5 mm

starting at Ø 16 - 20 mm  
for insert with D min. 6.8 - 7.8 mm  
and D min. 7.8 - 10.5 mm

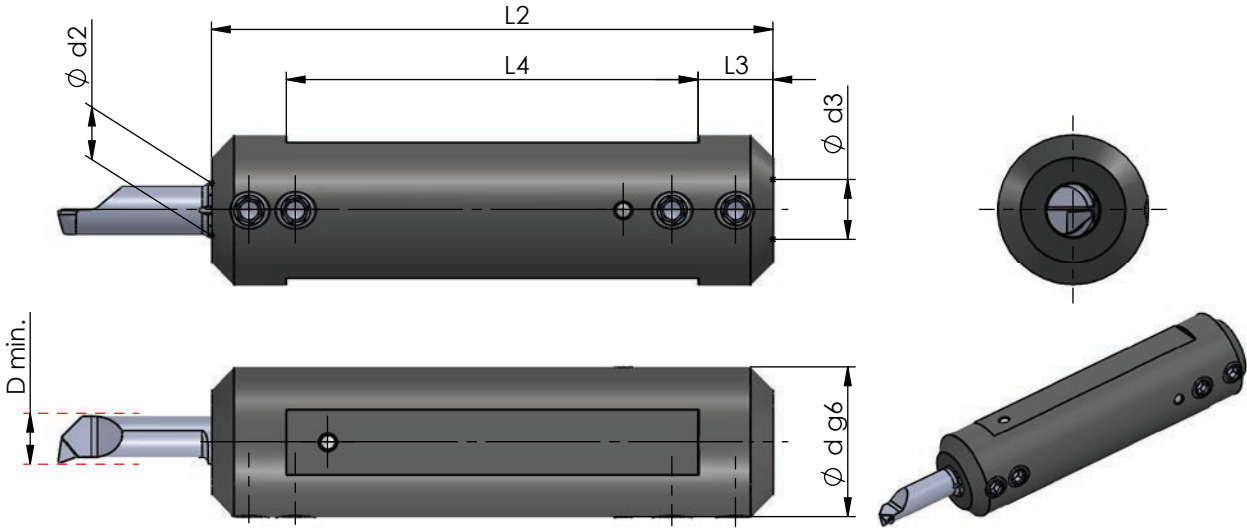

Klemmhalter für rechte und linke  
Schneideinsätze einsetzbar

toolholder for right and left  
inserts usable

Abmessungen in mm

dimensions in mm

Bestellnummer part number	Abmessungen in mm				Spannschraube screw	Schraubenschlüssel wrench	Anzugs- drehmoment torque	Schneideinsatz insert	
	Ø d g6	L2	L3	L4				Ø d2 ≤	Ø d h6 Schneideinsatz insert
687.0016-D	16	75	10	55	110.687-16	111.687	2.5 Nm	7	8
687.0020-D	20	90	10	70	110.687-16	111.687	2.5 Nm	7	8
681.0020-D	20	100	10	80	110.640	111.645	1.2 Nm	8	10

Bestellbeispiel:  
687.0016-D



# ULTRAMINI

Bohrungsbearbeitung  
ab  $\varnothing 0.2$  mm

grooving, boring and profiling  
starting at  $\varnothing 0.2$  mm

# Typ 687.PT

Klemmhalter,  
Premiumline mit  
verbesserter Kühlung

toolholder,  
Premiumline with  
improved cooling

ab  $\varnothing 16 - 20$  mm  
für Schneideinsatz mit  
D min. 6.8 - 7.8 mm

starting at  $\varnothing 16 - 20$  mm  
for insert with  
D min. 6.8 - 7.8 mm

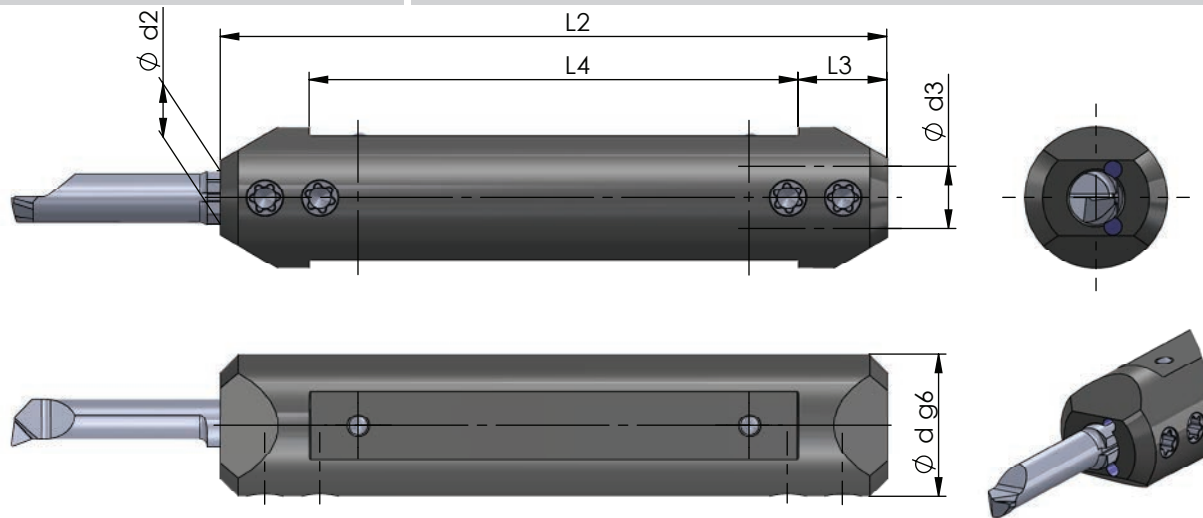

Klemmhalter für rechte und linke  
Schneideinsätze einsetzbar

toolholder for right and left  
inserts usable

Abmessungen in mm

dimensions in mm

Bestellnummer part number	Abmessungen in mm				Spannschraube screw	Schraubenschlüssel wrench	Anzugs- drehmoment torque	Schneideinsatz insert	
	$\varnothing d g6$	L2	L3	L4				$\varnothing d2$	$\varnothing d h6$
687.PT16-D	16	75	10	55	PT12	T10F	1.2 Nm	7	8
687.PT20-D	20	90	10	70	PT16	T10F	1.2 Nm	7	8

Bestellbeispiel:  
687.PT16-D



**ULTRAMINI**

Bohrungsbearbeitung  
ab Ø 0.2 mm

grooving, boring and profiling  
starting at Ø 0.2 mm

**Typ 640 / 650 / 660 / 670 / 680**

Klemmhalter

toolholder

ab Ø 12 / 12.7 mm  
für Schneideinsatz mit  
D min. 0.2 - 7.8 mm

starting at Ø 12 / 12.7 mm  
for insert with  
D min. 0.2 - 7.8 mm

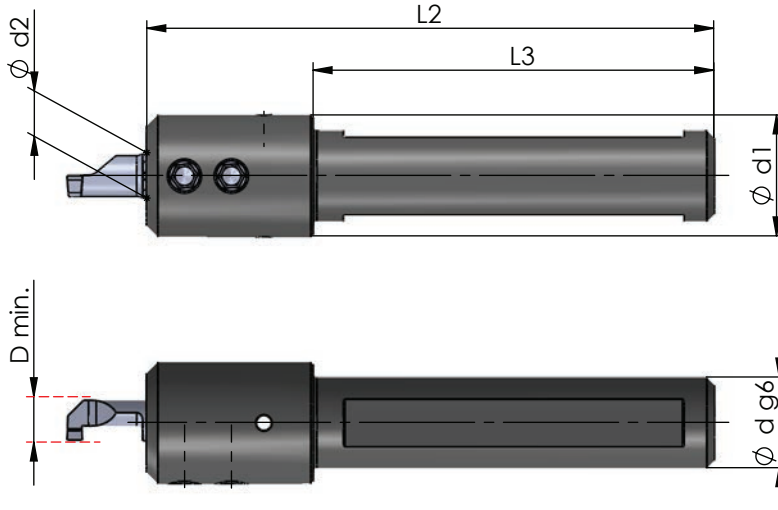

Klemmhalter für rechte und linke  
Schneideinsätze einsetzbar

toolholder for right and left  
inserts usable

Abmessungen in mm

dimensions in mm

Bestellnummer part number	Ø d g6	Ø d (inch)	L2	Ø d1	L3	Spannschraube screw	Schraubenschlüssel wrench	Anzugs- drehmoment torque	Ø d2 Ø d h6 Schneideinsatz insert
640.0012	12		75	16	53	G016	111.645	1.2 Nm	4
650.0012	12		75	16	53	G016	111.645	1.2 Nm	5
660.0012	12		75	16	53	G016	111.645	1.2 Nm	6
660.0127	12.7	1/2"	75	16	53	G016	111.645	1.2 Nm	6
670.0012	12		75	16	53	G016	111.645	1.2 Nm	7
670.0127	12.7	1/2"	75	16	53	G016	111.645	1.2 Nm	7
680.0012	12		75	16	53	G016	111.645	1.2 Nm	8
680.0127	12.7	1/2"	75	16	53	G016	111.645	1.2 Nm	8

Bestellbeispiel:  
640.0012

order example:  
640.0012



## ULTRAMINI

Bohrungsbearbeitung  
ab  $\varnothing 0.2$  mm

grooving, boring and profiling  
starting at  $\varnothing 0.2$  mm

## Typ 645.K

Klemmhalter, ideal für Typ 520  
und mit zentraler Kühlbohrung

toolholder, perfect for type 520  
and with central cooling bore

ab  $\varnothing 12 - 20$  mm  
für Schneideinsatz mit  
D min. 0.2 - 5.0 mm

starting at  $\varnothing 12 - 20$  mm  
for insert with  
D min. 0.2 - 5.0 mm

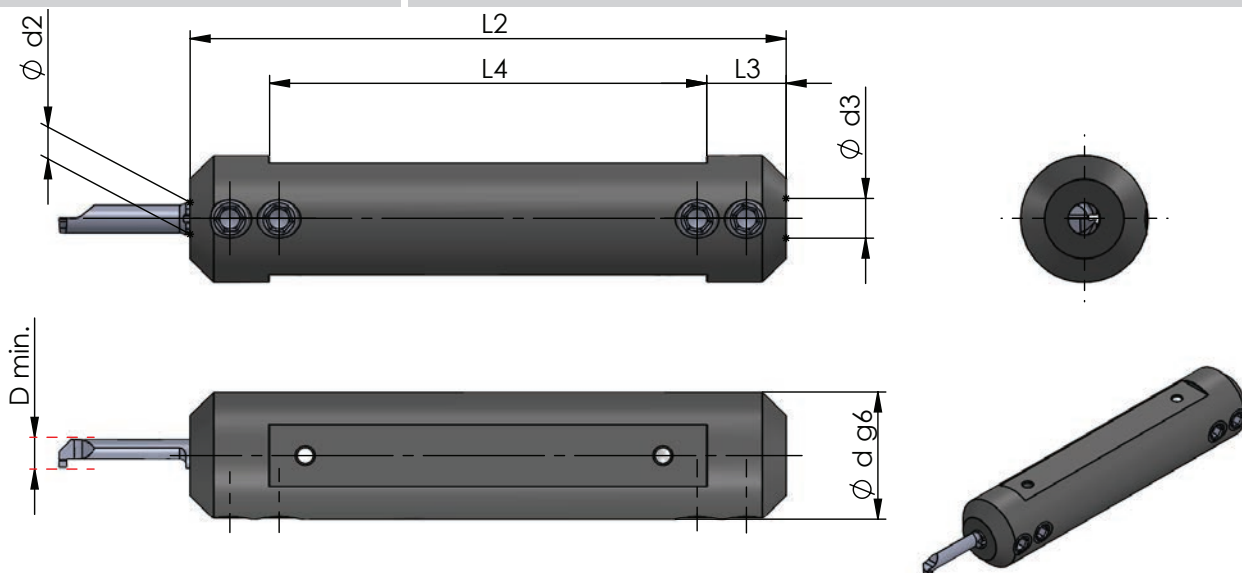

Klemmhalter für rechte und linke  
Schneideinsätze einsetzbar

toolholder for right and left  
inserts usable

Abmessungen in mm

dimensions in mm

Bestellnummer part number	$\varnothing d6$	L2	L3	L4	Spannschraube screw	Schraubenschlüssel wrench	Anzugs- drehmoment torque	Schneideinsatz insert	
								$\varnothing d2$	$\varnothing d3$
645.K012-D	12	75	10	55	110.640	111.645	1.2 Nm	4	5
645.K016-D	16	75	10	55	110.645	111.645	1.2 Nm	4	5
645.K020-D	20	90	10	70	110.650	111.645	1.2 Nm	4	5

Bestellbeispiel:  
645.K012-D



**ULTRAMINI**

Bohrungsbearbeitung  
ab  $\varnothing 0.2$  mm

grooving, boring and profiling  
starting at  $\varnothing 0.2$  mm

**Typ 676.K**

Klemmhalter, ideal für Typ 520  
und mit zentraler Kühlbohrung

toolholder, perfect for type 520  
and with central cooling bore

ab  $\varnothing 16 - 20$  mm  
für Schneideinsatz mit  
D min. 6.0 - 7.0 mm

starting at  $\varnothing 16 - 20$  mm  
for insert with  
D min. 6.0 - 7.0 mm

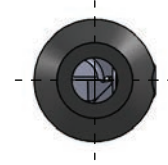
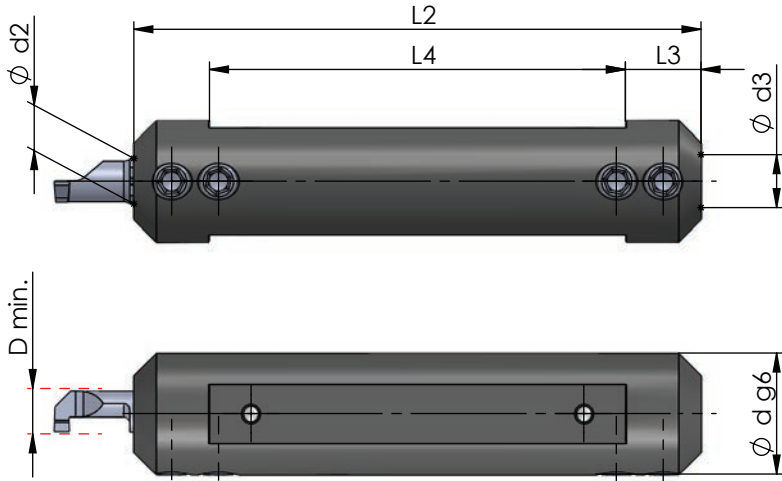

Klemmhalter für rechte und linke  
Schneideinsätze einsetzbar

toolholder for right and left  
inserts usable

Abmessungen in mm

dimensions in mm

Bestellnummer part number	$\varnothing d g6$	L2	L3	L4	Spannschraube screw	Schraubenschlüssel wrench	Anzugs- drehmoment torque	$\varnothing d2$	$\varnothing d h6$
								Schneideinsatz insert	Schneideinsatz insert
676.K016-D	16	75	10	55	110.645	111.645	1.2 Nm	6	7
676.K020-D	20	90	10	70	110.650	111.645	1.2 Nm	6	7

Bestellbeispiel:  
676.K016-D



## ULTRAMINI

Bohrungsbearbeitung  
ab Ø 0.2 mm

grooving, boring and profiling  
starting at Ø 0.2 mm

## Typ UMST

Klemmhalter,  
mit Hochdruckanschluss  
für Langdreher

toolholder,  
with high-pressure connection  
for Swiss type Machines

ab Ø 16 - 28 mm  
für Schneideinsatz mit  
D min. 0.2 - 7.8 mm

starting at Ø 16 - 28 mm  
for insert with  
D min. 0.2 - 7.8 mm

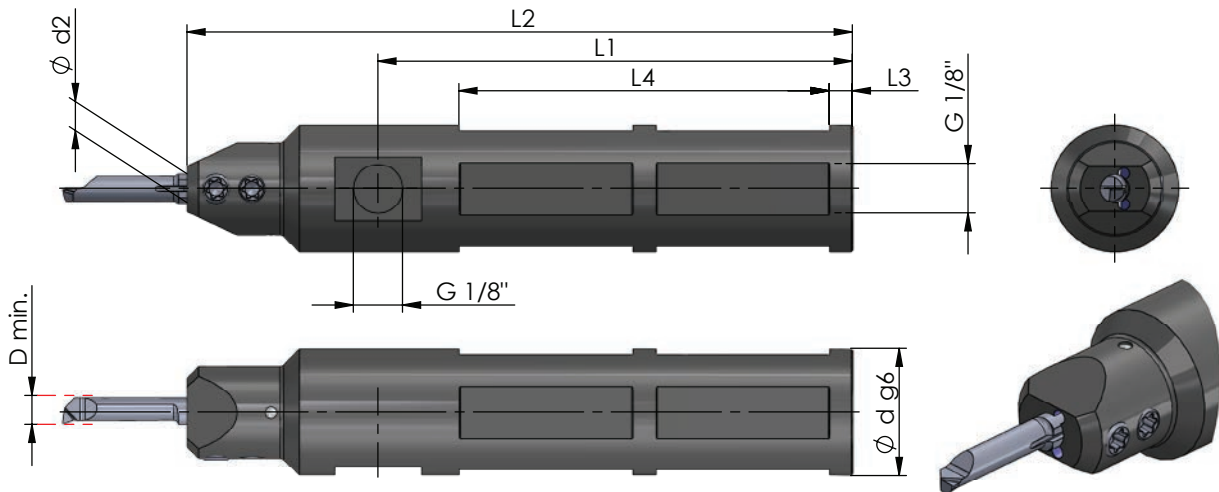

Klemmhalter für rechte und linke  
Schneideinsätze einsetzbar

toolholder for right and left  
inserts usable

Abmessungen in mm

dimensions in mm

Bestellnummer part number	Ø d g6		L1	L2	L3	L4	Spannschraube screw	Schrauben- schlüssel wrench	Anzugs- drehmoment torque	Schneideinsatz insert	
	Ø d2	Ø d h6									
UMST.0016.4	16		82	115	4	64	PT16	T10F	1.2 Nm	4	
UMST.0016.5	16		82	115	4	64	PT16	T10F	1.2 Nm	5	
UMST.0016.6	16		82	115	4	64	PT16	T10F	1.2 Nm	6	
UMST.0016.7	16		82	115	4	64	PT16	T10F	1.2 Nm	7	
UMST.0016.8	16		82	115	4	64	PT16	T10F	1.2 Nm	8	
UMST.001905.4	19.05	3/4"	82	115	4	64	PT16	T10F	1.2 Nm	4	
UMST.001905.5	19.05	3/4"	82	115	4	64	PT16	T10F	1.2 Nm	5	
UMST.001905.6	19.05	3/4"	82	115	4	64	PT16	T10F	1.2 Nm	6	
UMST.001905.7	19.05	3/4"	82	115	4	64	PT16	T10F	1.2 Nm	7	
UMST.001905.8	19.05	3/4"	82	115	4	64	PT16	T10F	1.2 Nm	8	
UMST.0020.4	20		82	115	4	64	PT16	T10F	1.2 Nm	4	
UMST.0020.5	20		82	115	4	64	PT16	T10F	1.2 Nm	5	
UMST.0020.6	20		82	115	4	64	PT16	T10F	1.2 Nm	6	
UMST.0020.7	20		82	115	4	64	PT16	T10F	1.2 Nm	7	
UMST.0020.8	20		82	115	4	64	PT16	T10F	1.2 Nm	8	
↳ ...											

Bestellbeispiel:  
UMST.0016.4

order example:  
UMST.0016.4

## ULTRAMINI

Bohrungsbearbeitung  
ab Ø 0.2 mm

grooving, boring and profiling  
starting at Ø 0.2 mm

## Typ UMST

Klemmhalter,  
mit Hochdruckanschluss  
für Langdreher

toolholder,  
with high-pressure connection  
for Swiss type Machines

ab Ø 16 - 28 mm  
für Schneideinsatz mit  
D min. 0.2 - 7.8 mm

starting at Ø 16 - 28 mm  
for insert with  
D min. 0.2 - 7.8 mm

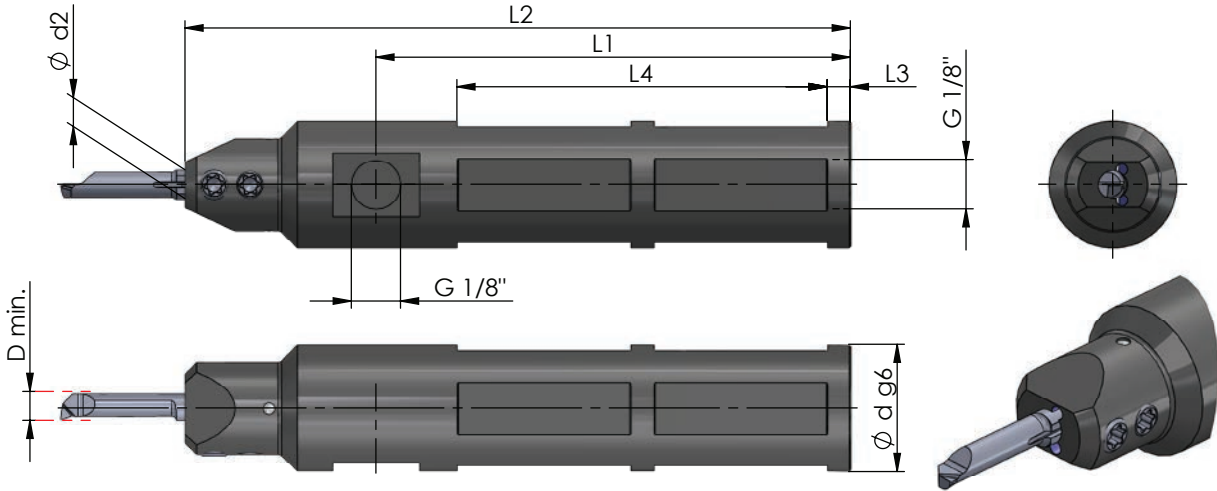

Klemmhalter für rechte und linke  
Schneideinsätze einsetzbar

toolholder for right and left  
inserts usable

Abmessungen in mm

dimensions in mm

Bestellnummer part number	Ø d g6	Ø d (inch)	L1	L2	L3	L4	Spannschraube screw	Schrauben- schlüssel wrench	Anzugs- drehmoment torque	Ø d2 Ø d h6 Schneideinsatz insert
⋮ ↴										
UMST.0022.4	22		82	115	4	64	PT16	T10F	1.2 Nm	4
UMST.0022.5	22		82	115	4	64	PT16	T10F	1.2 Nm	5
UMST.0022.6	22		82	115	4	64	PT16	T10F	1.2 Nm	6
UMST.0022.7	22		82	115	4	64	PT16	T10F	1.2 Nm	7
UMST.0022.8	22		82	115	4	64	PT16	T10F	1.2 Nm	8
UMST.00254.4	25.4	1"	82	115	4	64	PT16	T10F	1.2 Nm	4
UMST.00254.5	25.4	1"	82	115	4	64	PT16	T10F	1.2 Nm	5
UMST.00254.6	25.4	1"	82	115	4	64	PT16	T10F	1.2 Nm	6
UMST.00254.7	25.4	1"	82	115	4	64	PT16	T10F	1.2 Nm	7
UMST.00254.8	25.4	1"	82	115	4	64	PT16	T10F	1.2 Nm	8
UMST.0028.4	28		82	115	4	64	PT16	T10F	1.2 Nm	4
UMST.0028.5	28		82	115	4	64	PT16	T10F	1.2 Nm	5
UMST.0028.6	28		82	115	4	64	PT16	T10F	1.2 Nm	6
UMST.0028.7	28		82	115	4	64	PT16	T10F	1.2 Nm	7
UMST.0028.8	28		82	115	4	64	PT16	T10F	1.2 Nm	8

Bestellbeispiel:  
UMST.0022.4

order example:  
UMST.0022.4



## ULTRAMINI

Bohrungsbearbeitung  
ab Ø 0.2 mm

grooving, boring and profiling  
starting at Ø 0.2 mm

## Typ UM600H

High-Performance-Klemmhalter  
mit Kühlmittelsanschluss

high-performance toolholder  
with coolant connection

ab Ø 12 - 28 mm  
für Schneideinsatz mit  
D min. 0.2 - 7.0 mm

starting at Ø 12 - 28 mm  
for insert with  
D min. 0.2 - 7.0 mm

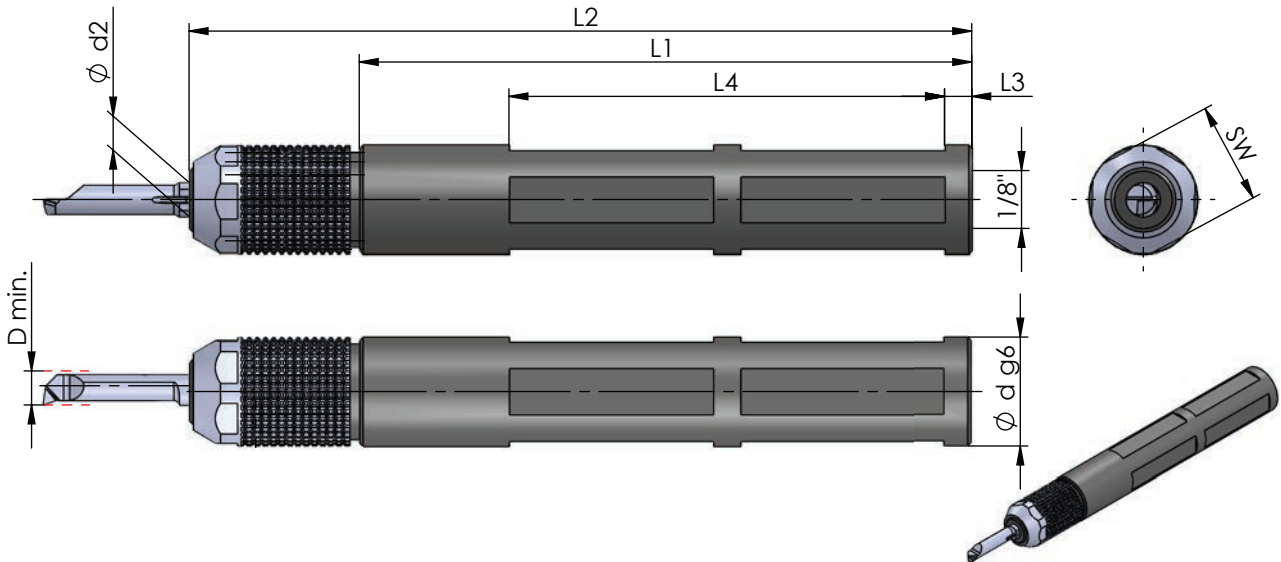

Klemmhalter für rechte und linke  
Schneideinsätze einsetzbar

toolholder for right and left  
inserts usable

Abmessungen in mm

dimensions in mm

Bestellnummer part number	Ø d g6	Ø d (inch)	Längen				Überwurfmutter union nut	Klemmkeil nut	Ø d2 Ø d h6 Schneideinsatz insert
			L2	L1	L3	L4			
UM600H.0012.4	12		115	90	4	64	UM600H.M4	UM600H.K	4
UM600H.0012.5	12		115	90	4	64	UM600H.M5	UM600H.K	5
UM600H.0012.6	12		115	90	4	64	UM600H.M6	UM600H.K	6
UM600H.0012.7	12		115	90	4	64	UM600H.M7	UM600H.K	7
UM600H.0016.4	16		115	90	4	64	UM600H.M4	UM600H.K	4
UM600H.0016.5	16		115	90	4	64	UM600H.M5	UM600H.K	5
UM600H.0016.6	16		115	90	4	64	UM600H.M6	UM600H.K	6
UM600H.0016.7	16		115	90	4	64	UM600H.M7	UM600H.K	7

### Merkmale:

- Handspannung ohne zusätzlichen Schlüssel
- Wiederholgenauigkeit ± 0,005 mm (hohe Präzision)
- einfachste Bedienung
- ideal bei engen Platzverhältnissen
- Spannung mit Standardschlüssel SW15 möglich
- bei Einsatz von Rückwärtsdreher oder Hochdruckkühlung muss mit Schlüssel gespannt werden

### characteristics:

- manual clamping without additional wrench
- continuous repeatability ± 0,005 mm (high precision)
- simplest operation
- ideal where space is tight
- clamping by standard wrench SW15 is possible
- when backboring or high-pressure cooling you have to clamp with a wrench

Bestellbeispiel:  
UM600H.0012.4

order example:  
UM600H.0012.4

**ULTRAMINI**

Bohrungsbearbeitung  
ab Ø 0.2 mm

grooving, boring and profiling  
starting at Ø 0.2 mm

**Typ UM600H**

High-Performance-Klemmhalter  
mit Kühlmittelsanschluss

high-performance toolholder  
with coolant connection

ab Ø 12 - 28 mm  
für Schneideinsatz mit  
D min. 0.2 - 7.0 mm

starting at Ø 12 - 28 mm  
for insert with  
D min. 0.2 - 7.0 mm

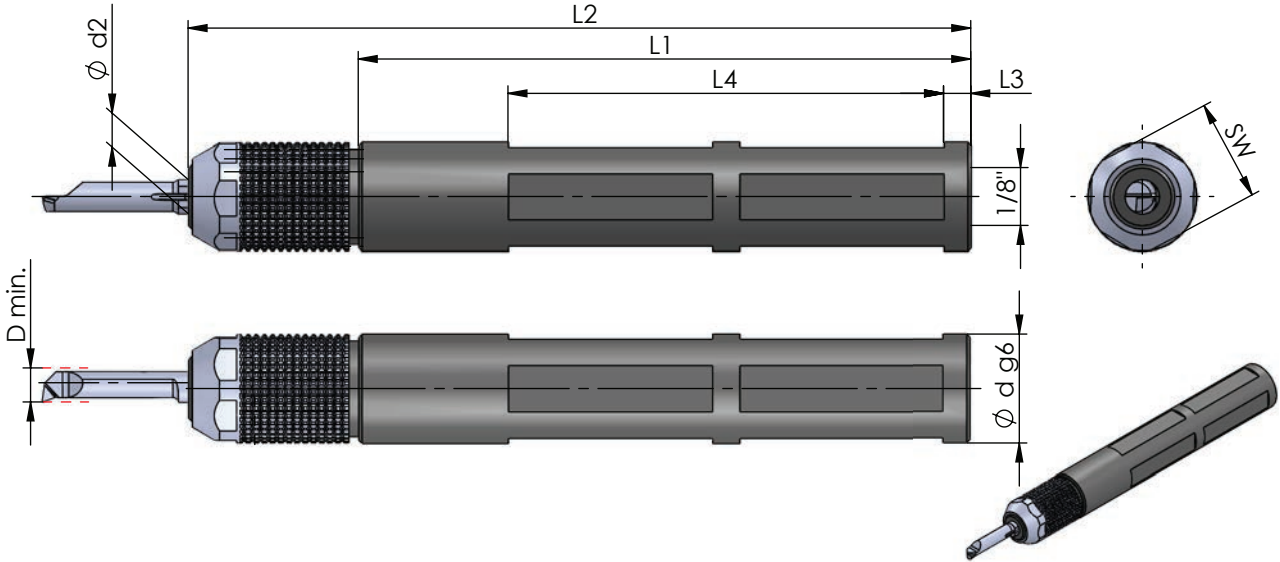

Klemmhalter für rechte und linke  
Schneideinsätze einsetzbar

toolholder for right and left  
inserts usable

Abmessungen in mm

dimensions in mm

Bestellnummer part number	Ø d g6		L2	L1	L3	L4	Überwurfmutter union nut	Klemmkeil nut	Ø d2 Ø d h6 Schneideinsatz insert
	Ø d (inch)								
⋮ ↓									
UM600H.001905.4	19.05	3/4"	115	90	4	64	UM600H.M4	UM600H.K	4
UM600H.001905.5	19.05	3/4"	115	90	4	64	UM600H.M5	UM600H.K	5
UM600H.001905.6	19.05	3/4"	115	90	4	64	UM600H.M6	UM600H.K	6
UM600H.001905.7	19.05	3/4"	115	90	4	64	UM600H.M7	UM600H.K	7
UM600H.0020.4	20		115	90	4	64	UM600H.M4	UM600H.K	4
UM600H.0020.5	20		115	90	4	64	UM600H.M5	UM600H.K	5
UM600H.0020.6	20		115	90	4	64	UM600H.M6	UM600H.K	6
UM600H.0020.7	20		115	90	4	64	UM600H.M7	UM600H.K	7
UM600H.0022.4	22		115	90	4	64	UM600H.M4	UM600H.K	4
UM600H.0022.5	22		115	90	4	64	UM600H.M5	UM600H.K	5
UM600H.0022.6	22		115	90	4	64	UM600H.M6	UM600H.K	6
UM600H.0022.7	22		115	90	4	64	UM600H.M7	UM600H.K	7
↳ ...									

Bestellbeispiel:  
UM600H.001905.4

order example:  
UM600H.001905.4



# ULTRAMINI

Bohrungsbearbeitung  
ab Ø 0.2 mm

grooving, boring and profiling  
starting at Ø 0.2 mm

# Typ UM600H

High-Performance-Klemmhalter  
mit Kühlmittelsanschluss

high-performance toolholder  
with coolant connection

ab Ø 12 - 28 mm  
für Schneideinsatz mit  
D min. 0.2 - 7.0 mm

starting at Ø 12 - 28 mm  
for insert with  
D min. 0.2 - 7.0 mm

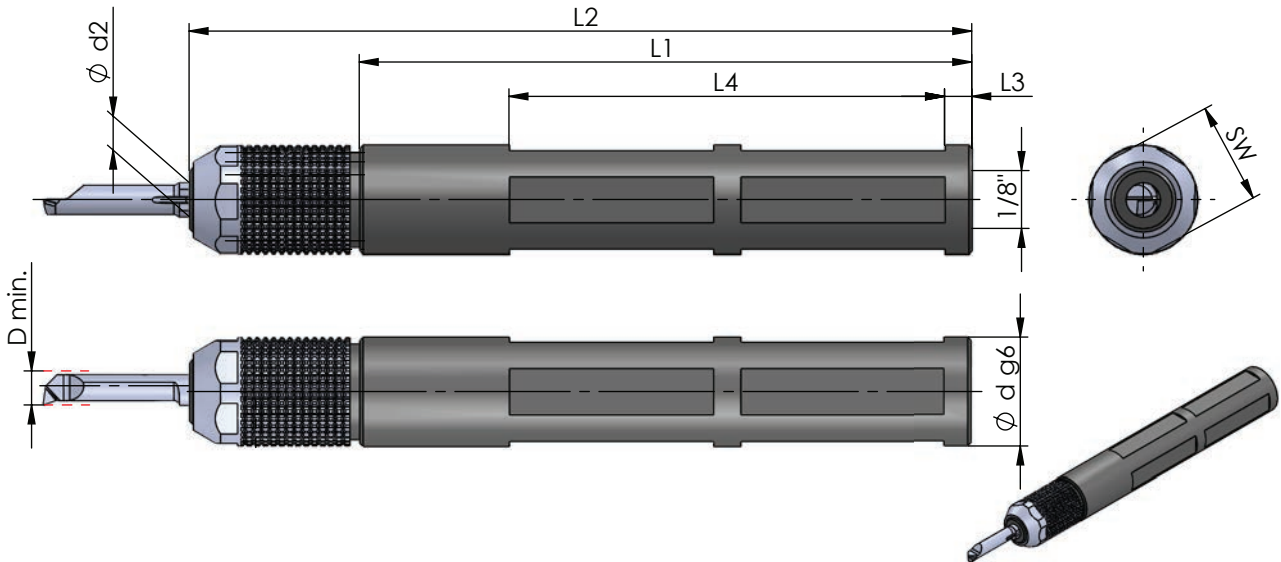

Klemmhalter für rechte und linke  
Schneideinsätze einsetzbar

toolholder for right and left  
inserts usable

Abmessungen in mm

dimensions in mm

Bestellnummer part number	Ø d g6	Ø d (inch)	L2	L1	L3	L4	Überwurfmutter union nut	Klemmkeil nut	Ø d2 Ø d h6 Schneideinsatz insert
...									
UM600H.0025.4	25		115	90	4	64	UM600H.M4	UM600H.K	4
UM600H.0025.5	25		115	90	4	64	UM600H.M5	UM600H.K	5
UM600H.0025.6	25		115	90	4	64	UM600H.M6	UM600H.K	6
UM600H.0025.7	25		115	90	4	64	UM600H.M7	UM600H.K	7
UM600H.00254.4	25.4	1"	115	90	4	64	UM600H.M4	UM600H.K	4
UM600H.00254.5	25.4	1"	115	90	4	64	UM600H.M5	UM600H.K	5
UM600H.00254.6	25.4	1"	115	90	4	64	UM600H.M6	UM600H.K	6
UM600H.00254.7	25.4	1"	115	90	4	64	UM600H.M7	UM600H.K	7
UM600H.0028.4	28		115	90	4	64	UM600H.M4	UM600H.K	4
UM600H.0028.5	28		115	90	4	64	UM600H.M5	UM600H.K	5
UM600H.0028.6	28		115	90	4	64	UM600H.M6	UM600H.K	6
UM600H.0028.7	28		115	90	4	64	UM600H.M7	UM600H.K	7

Bestellbeispiel:  
UM600H.0025.4



## ULTRAMINI

Bohrungsbearbeitung  
ab  $\varnothing 0.2$  mm

grooving, boring and profiling  
starting at  $\varnothing 0.2$  mm

## Typ UM

Klemhalter,  
Quadratschaft

toolholder,  
square shank

ab 10.0 x 10.0 mm  
für Schneideinsätze  
D min. 0.2 - 7.0 mm

starting at 10.0 x 10.0 mm  
for insert  
D min. 0.2 - 7.0 mm

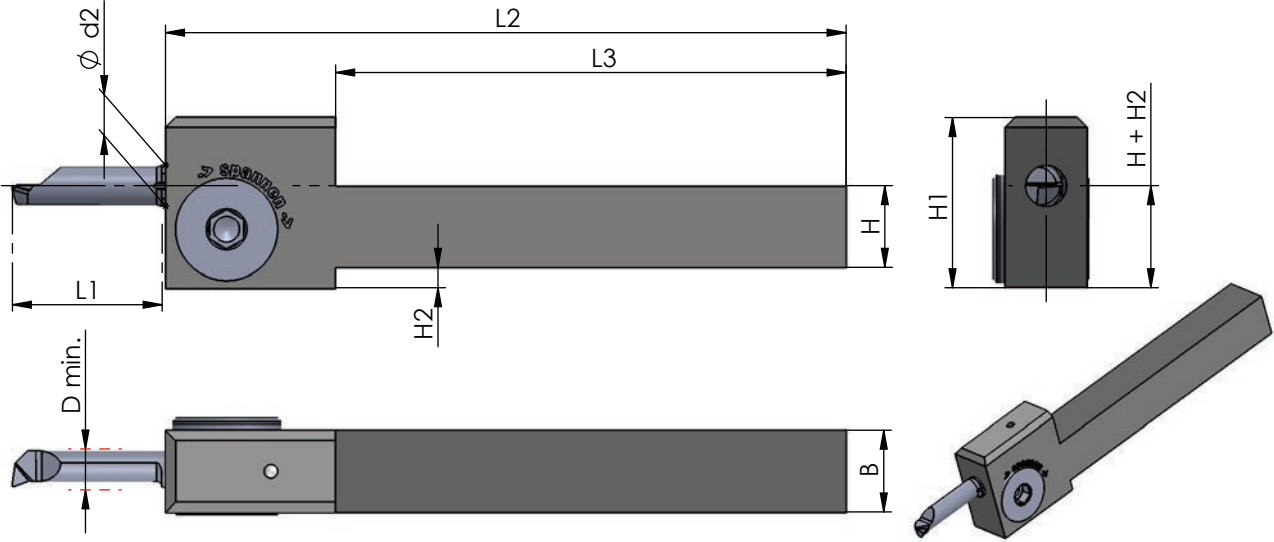

Klemhalter für rechte und linke  
Schneideinsätze einsetzbar

toolholder for right and left  
inserts usable

Abmessungen in mm

dimensions in mm

Bestellnummer part number	H	B	L2	L3	H1	H2	L1	Schneide / insert	Klemmelement locking element	Schraubenschlüssel wrench	Anzugs- drehmoment torque	$\varnothing d2$ $\varnothing d h6$ Schneideinsatz insert
UM.1010.4	10	10	100	75	22	2			UM12	111.INB5	2.0 NM	4
UM.1010.5	10	10	100	75	22	2			UM12	111.INB5	2.0 NM	5
UM.1212.4	12	12	100	75	22				UM12	111.INB5	2.0 NM	4
UM.1212.5	12	12	100	75	22				UM12	111.INB5	2.0 NM	5
UM.1212.6	12	12	100	75	25	3	-2		UM16	111.INB5	2.0 NM	6
UM.1616.4	16	16	125	100	25				UM12	111.INB5	2.0 NM	4
UM.1616.5	16	16	125	100	25				UM12	111.INB5	2.0 NM	5
UM.1616.6	16	16	125	100	25		-2		UM16	111.INB5	2.0 NM	6
UM.1616.7	16	16	125	100	25		-2		UM16	111.INB5	2.0 NM	7

Bestellbeispiel:  
UM.1010.4

order example:  
UM.1010.4

# ULTRAMINI

Bohrungsbearbeitung  
ab  $\varnothing 0.2$  mm

grooving, boring and profiling  
starting at  $\varnothing 0.2$  mm

# Typ .IK.UHCM

Klemmhalter,  
Quadratschaft,  
mit Innenkühlung

toolholder,  
square shank,  
with internal cooling

ab 12.0 x 12.0 mm  
für Schneideinsätze  
D min. 0.2 - 7.0 mm

starting at 12.0 x 12.0 mm  
for insert  
D min. 0.2 - 7.0 mm

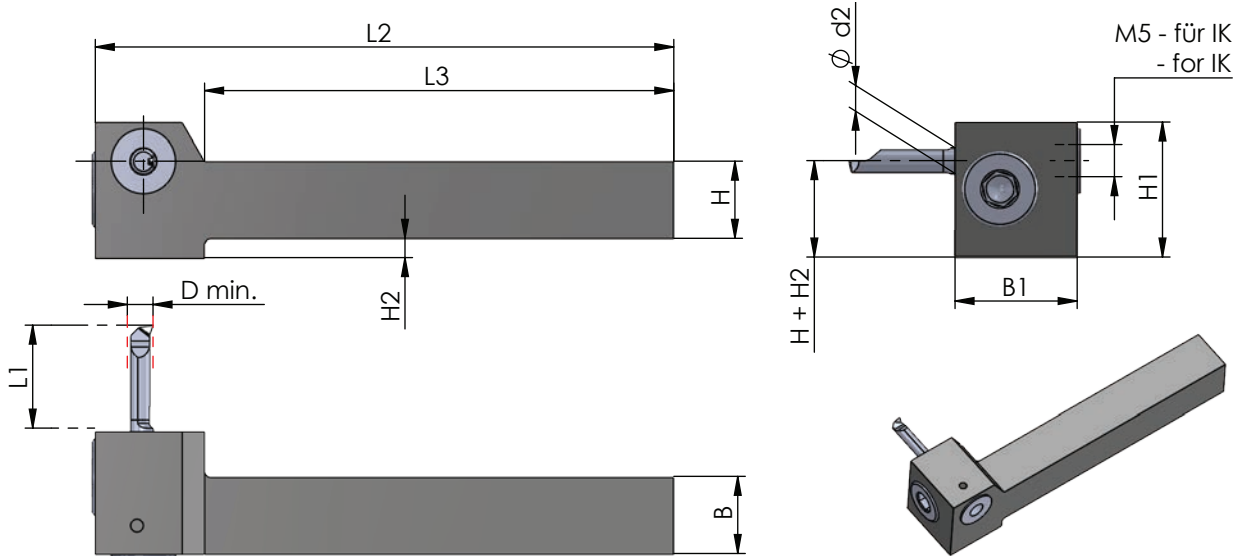

Klemmhalter für rechte und linke  
Schneideinsätze einsetzbar

Abbildung: linksschneidend

Abmessungen in mm

toolholder for right and left  
inserts usable

lefthand version shown

dimensions in mm

Bestellnummer part number	H	B	L2	L3	B1	H1	H2	L1	Schneide / insert	Klemmelement locking element	Schraubenschlüssel wrench	Anzugs- drehmoment torque	$\varnothing d2$ $\varnothing d h6$ Schneideinsatz insert
R/L .IK.UHCM.1212.4	12	12	90	73	20	18				UM12	111.INB5	2.0 NM	4
R/L .IK.UHCM.1212.5	12	12	90	73	20	18				UM12	111.INB5	2.0 NM	5
R/L .IK.UHCM.1212.6	12	12	90	73	20	21	3	-2		UM16	111.INB5	2.0 NM	6
R/L .IK.UHCM.1212.7	12	12	90	73	20	21	3	-2		UM16	111.INB5	2.0 NM	7
R/L .IK.UHCM.1616.4	16	16	130	113	20	22				UM12	111.INB5	2.0 NM	4
R/L .IK.UHCM.1616.5	16	16	130	113	20	22				UM12	111.INB5	2.0 NM	5
R/L .IK.UHCM.1616.6	16	16	130	113	20	22		-2		UM16	111.INB5	2.0 NM	6
R/L .IK.UHCM.1616.7	16	16	130	113	20	22		-2		UM16	111.INB5	2.0 NM	7

Kühlmittldruck max. 10 bar

Bestellbeispiel:  
R.IK.UHCM.1212.4

Coolant pressure max. 10 bar

order example:  
R.IK.UHCM.1212.4





**ULTRAMINI**

Bohrungsbearbeitung  
ab Ø 0.2 mm

grooving, boring and profiling  
starting at Ø 0.2 mm

**Typ .UM.18 / .UM.28**

Klemmhalter,  
Quadratschaft,  
mit Innenkühlung

toolholder,  
square shank,  
with internal cooling

10.0 x 10.0 mm  
für Schneideinsätze  
D min. 0.2 - 7.0 mm

10.0 x 10.0 mm  
for insert  
D min. 0.2 - 7.0 mm

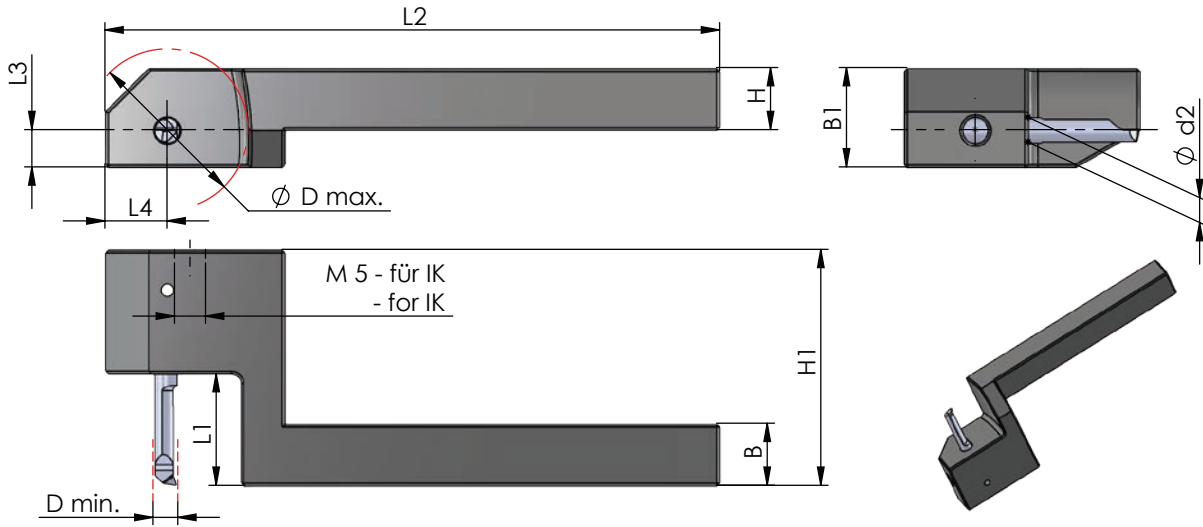

Rechts (R): wie gezeichnet  
Links (L): spiegelbildlich

Rechte Schneidpl. in rechte Halter  
Linke Schneidpl. in linkem Halter

Abmessungen in mm

righthand version (R): as shown  
lefthand version (L): mirror image

use RH insert in RH tool holder and  
LH insert in LH tool holder

dimensions in mm

Bestellnummer part number	H	B	L2	L1	L3	L4	H1	B1	Ø D max.	Spannschraube screw	Schraubenschlüssel wrench	Anzugs- drehmoment torque	Ø d2 Ø d h6 Schneideinsatz insert
R/L .UM.18.1010.4	10	10	99	18	6	10	38	16	26	110.650	111.645	1.2 Nm	4
R/L .UM.18.1010.5	10	10	99	18	6	10	38	16	26	110.650	111.645	1.2 Nm	5
R/L .UM.18.1010.6	10	10	99	18	6	10	38	16	26	110.650	111.645	1.2 Nm	6
R/L .UM.18.1010.7	10	10	99	18	6	10	38	16	26	110.650	111.645	1.2 Nm	7
R/L .UM.28.1010.4	10	10	99	28	6	10	48	16	26	110.650	111.645	1.2 Nm	4
R/L .UM.28.1010.5	10	10	99	28	6	10	48	16	26	110.650	111.645	1.2 Nm	5
R/L .UM.28.1010.6	10	10	99	28	6	10	48	16	26	110.650	111.645	1.2 Nm	6
R/L .UM.28.1010.7	10	10	99	28	6	10	48	16	26	110.650	111.645	1.2 Nm	7

Bestellbeispiel:  
für rechte Ausführung  
R.UM.18.1010.4

order-example:  
righthand version  
R.UM.18.1010.4

# ULTRAMINI

Bohrungsbearbeitung  
ab  $\varnothing 0.2$  mm

grooving, boring and profiling  
starting at  $\varnothing 0.2$  mm

## Typ .UM.18 / .UM.28

Klemmhalter,  
Quadratschaft,  
mit Innenkühlung

toolholder,  
square shank,  
with internal cooling

12.0 x 12.0 mm  
für Schneideinsätze  
D min. 0.2 - 7.0 mm

12.0 x 12.0 mm  
for insert  
D min. 0.2 - 7.0 mm

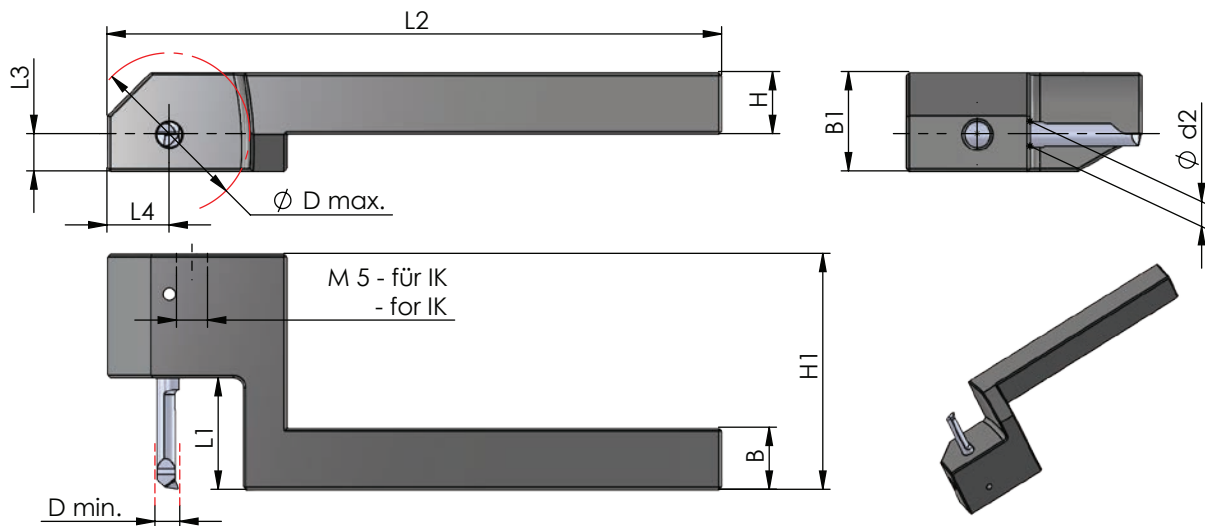

Rechts (R): wie gezeichnet  
Links (L): spiegelbildlich

Rechte Schneidpl. in rechte Halter  
Linke Schneidpl. in linkem Halter

Abmessungen in mm

righthand version (R): as shown  
lefthand version (L): mirror image

use RH insert in RH tool holder and  
LH insert in LH tool holder

dimensions in mm

Bestellnummer part number	H	B	L2	L1	L3	L4	H1	B1	Ø D max.	Spannschraube screw	Schraubenschlüssel wrench	Anzugs- drehmoment torque	Ø d2 Ø d h6 Schneideinsatz insert
R/L .UM.18.1212.4	12	12	99	18	6	10	38	18	26	110.650	111.645	1.2 Nm	4
R/L .UM.18.1212.5	12	12	99	18	6	10	38	18	26	110.650	111.645	1.2 Nm	5
R/L .UM.18.1212.6	12	12	99	18	6	10	38	18	26	110.650	111.645	1.2 Nm	6
R/L .UM.18.1212.7	12	12	99	18	6	10	38	18	26	110.650	111.645	1.2 Nm	7
R/L .UM.28.1212.4	12	12	99	28	6	10	48	18	26	110.650	111.645	1.2 Nm	4
R/L .UM.28.1212.5	12	12	99	28	6	10	48	18	26	110.650	111.645	1.2 Nm	5
R/L .UM.28.1212.6	12	12	99	28	6	10	48	18	26	110.650	111.645	1.2 Nm	6
R/L .UM.28.1212.7	12	12	99	28	6	10	48	18	26	110.650	111.645	1.2 Nm	7

Bestellbeispiel:  
für rechte Ausführung  
R.UM.18.1212.4

order-example:  
righthand version  
R.UM.18.1212.4

**ULTRAMINI**

Bohrungsbearbeitung  
ab  $\varnothing 0.2$  mm

grooving, boring and profiling  
starting at  $\varnothing 0.2$  mm

**Typ TD0710**

Klemmhalter,  
Rechteckschaft  
für Tornos DECO 7/10

toolholder,  
rectangle shank  
for Tornos DECO 7/10

für Schneideinsätze  
D min. 0.2 - 7.0 mm

for insert  
D min. 0.2 - 7.0 mm

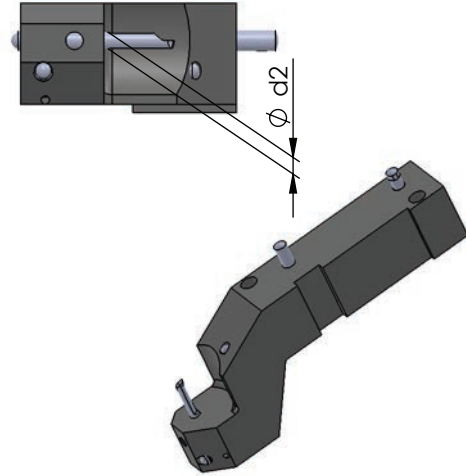
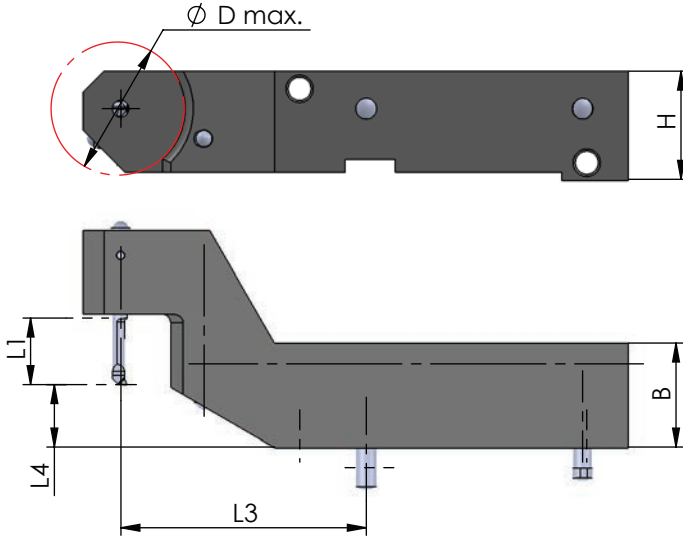

Rechts (R): wie gezeichnet  
Links (L): spiegelbildlich

Rechte Schneidpl. in rechte Halter  
Linke Schneidpl. in linkem Halter

Abmessungen in mm

righthand version (R): as shown  
lefthand version (L): mirror image

use RH insert in RH tool holder and  
LH insert in LH tool holder

dimensions in mm

Bestellnummer part number	H	B	L1	L3	L4	Ø D max.	Spannschraube screw	Schraubenschlüssel wrench	Anzugs- drehmoment torque	Ø d2
										Ø d h6 Schneideinsatz insert
R/L .TD0710.16.4	26	25	16	59	15	32	G016	111.645	1.2 Nm	4
R/L .TD0710.16.5	26	25	16	59	15	32	G016	111.645	1.2 Nm	5
R/L .TD0710.16.6	26	25	16	59	15	32	G016	111.645	1.2 Nm	6
R/L .TD0710.16.7	26	25	16	59	15	32	G016	111.645	1.2 Nm	7

Bestellbeispiel:  
für rechte Ausführung  
R.TD0710.16.4

order-example:  
righthand version  
R.TD0710.16.4



## ULTRAMINI

Bohrungsbearbeitung  
ab  $\varnothing 0.2 \text{ mm}$

grooving, boring and profiling  
starting at  $\varnothing 0.2 \text{ mm}$

## Typ UMHV

Höhenverstellbarer Klemmhalter und  
Reduzierhülse für Rückseiten-  
bearbeitung auf Langdrehautomaten

height adjustable toolholder and  
reduction bush for rear end machining  
on Swiss type lathes

ab  $\varnothing 4 - 10 \text{ mm}$   
für Schneideinsatz  
ab  $D \text{ min. } 0.2 \text{ mm}$

starting at  $\varnothing 4 - 10 \text{ mm}$   
for insert starting at  
 $D \text{ min. } 0.2 \text{ mm}$

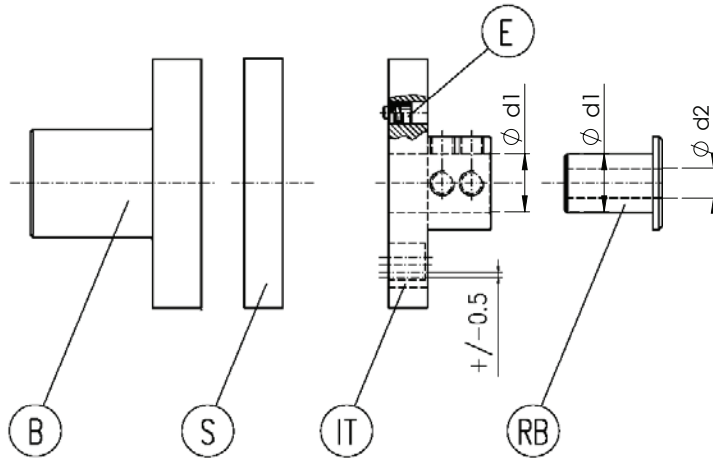

Abmessungen in mm

dimensions in mm

Bestellnummer part number	Position	Bezeichnung description	Ø		Ø d1 / Ø d2 Ø d h6 Schneideinsatz insert
			d1	d2	
UMHV-IT020110	IT		10		10
UMHV-IT050110	IT	Klemmhalter Innendrehen / toolholder internal turning	10		10
UMHV-IT90F0110	IT		10		10
UMHV-RBD1004	RB			4	4
UMHV-RBD1005	RB			5	5
UMHV-RBD1006	RB	Reduzierhülse / reduction bush		6	6
UMHV-RBD1007	RB			7	7
UMHV-RBD1008	RB			8	8
auf Anfrage / on request	B	Grundhalter / basic toolholder			
auf Anfrage / on request	S	Zwischenplatte / spacer			
auf Anfrage / on request	E	Excenter / excenter			

Bestellbeispiel:  
UMHV-IT020110

order example:  
UMHV-IT020110

## ULTRAMINI

Bohrungsbearbeitung  
ab  $\varnothing$  0.2 mm

grooving, boring and profiling  
starting at  $\varnothing$  0.2 mm

## Impressionen

impressions

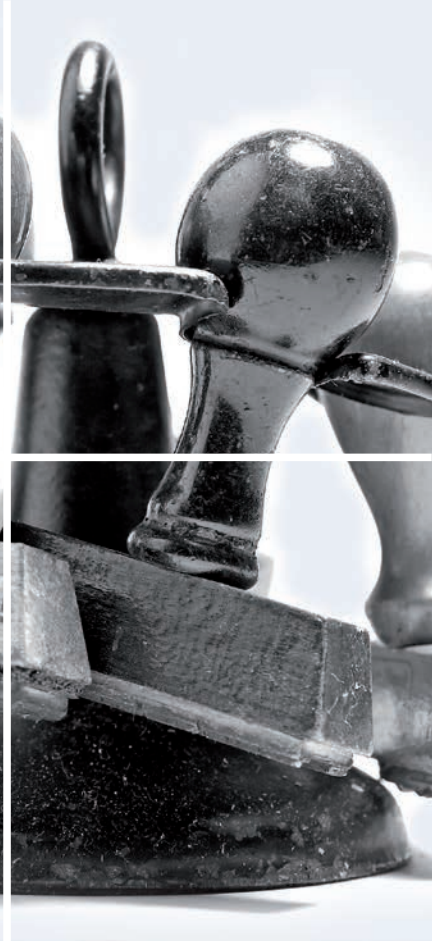

# ULTRAMINI

Bohrungsbearbeitung  
ab  $\varnothing 0.2$  mm

grooving, boring and profiling  
starting at  $\varnothing 0.2$  mm

# Typ 050

Audreihen und Kopieren

D min. 0.2 - 9.8 mm

boring and profiling

D min. 0.2 - 9.8 mm

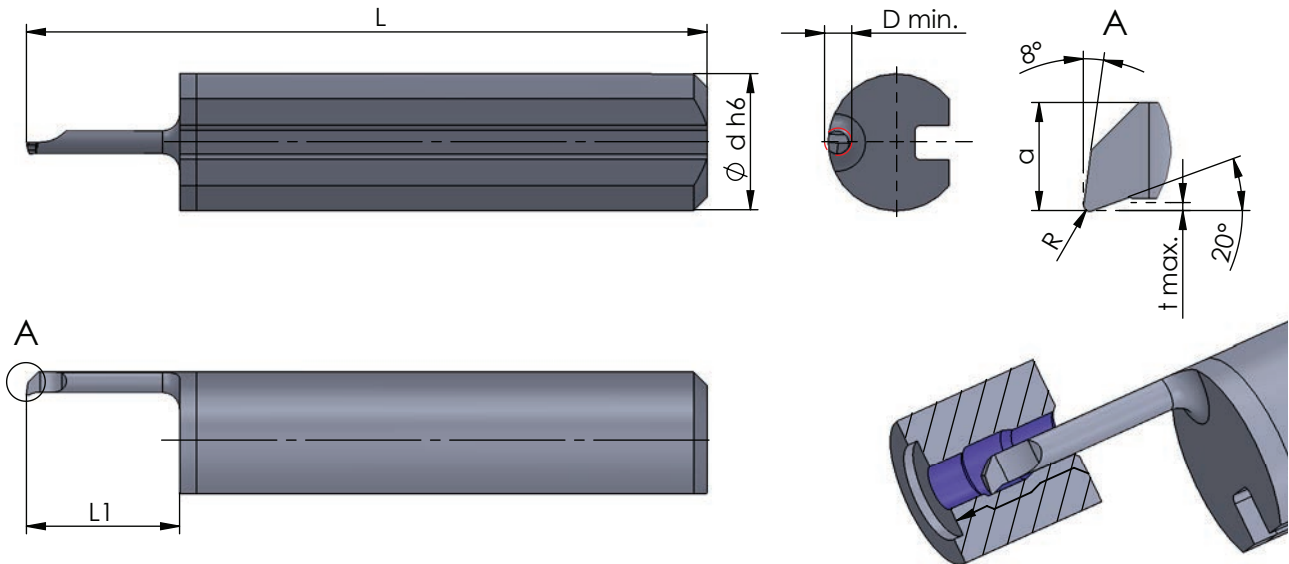

Rechts (R): wie gezeichnet  
Links (L): spiegelbildlich

\*zentrisch aufgebaut

Abmessungen in mm

righthand (R): as shown  
lefthand version (L): mirror image

\* central designed

dimensions in mm

Bestellnummer part number	R	f	a	L	L1	t max.	D min.	Ø d h6	K10F	CN45F	AL41F	PD2F	Klemmhalter Typ	toolholder type
													640... 645... ...4	
R/L 050.02-1 *	0.02		0.15	20	1.0	-	0.2	4.0	●					
R/L 050.05-2	0.04		0.4	20	2.0	-	0.5	4.0	●	●				
R/L 050.06-2	0.04		0.5	20	2.0	0.05	0.6	4.0	●	●				
R/L 050.06-3	0.04		0.5	20	3.0	0.05	0.6	4.0	●	●				
R/L 050.08-4	0.04		0.7	20	4.0	0.05	0.8	4.0	●	●				
R/L 050.1-5	0.05		0.9	20	4.5	0.1	1.0	4.0	●	●				
R/L 050.1-7	0.05		0.9	22	6.5	0.1	1.0	4.0	●	●				
R/L 050.1-8	0.05		0.9	22	8.0	0.1	1.0	4.0	●	●				
R/L 050.15-5	0.05		1.3	19	5.0	0.1	1.5	4.0	●	●				
R/L 050.15-10	0.05		1.3	24	10.0	0.1	1.5	4.0	●	●				
R/L 050.15-12	0.05		1.3	26	12.0	0.1	1.5	4.0	●					
R/L 050.2-5	0.05		1.7	19	5.0	0.1	2.0	4.0	●	●	●			
R/L 050.2-10	0.05		1.7	24	10.0	0.1	2.0	4.0	●	●	●			
R/L 050.2-15	0.05		1.7	29	15.0	0.1	2.0	4.0	●	●	●			
↳ ...														

Weitere HM Sorten können Sie in der Sortenübersicht im Kapitel "Technische Hinweise" und der Preisliste finden.

Bestellbeispiel:  
für rechte Ausführung und Sorte  
R050.02-1/K10F

More carbide grades you can find in the grades summary in the chapter "technical instructions" and in the price list.

order-example:  
righthand version and grade  
R050.02-1/K10F



**ULTRAMINI**

Bohrungsbearbeitung  
ab  $\varnothing$  0.2 mm

grooving, boring and profiling  
starting at  $\varnothing$  0.2 mm

**Typ 050**

Audreihen und Kopieren

D min. 0.2 - 9.8 mm

boring and profiling

D min. 0.2 - 9.8 mm

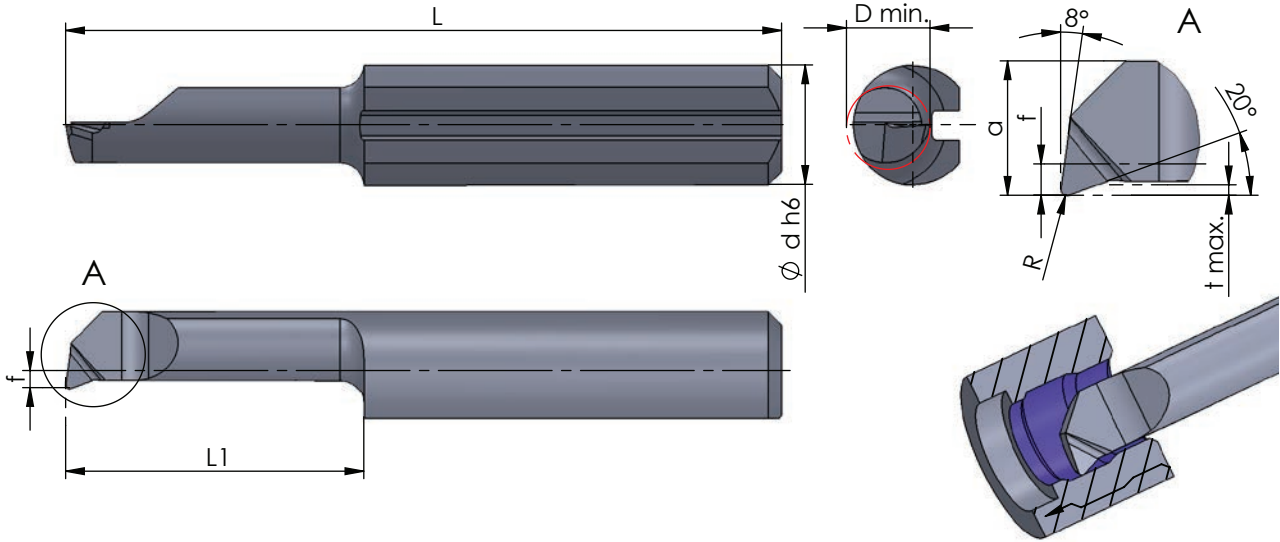

Rechts (R): wie gezeichnet  
Links (L): spiegelbildlich

righthand (R): as shown  
lefthand version (L): mirror image

Abmessungen in mm

dimensions in mm

Bestellnummer part number	R	f	a	L	L1	t max.	D min.	Ø d h6	K10F	CN45F	AL41F	PD2F	Klemmhalter Typ	toolholder type
													640, ... 645, ... ...4	
...														
R/L 050.25-5	0.05	0.2	2.2	19	5	0.15	2.5	4.0	●	●	●		640, ... 645, ... ...4	
R/L 050.25-10	0.05	0.2	2.2	24	10	0.15	2.5	4.0	●	●	●			
R/L 050.25-16	0.05	0.2	2.2	30	16	0.15	2.5	4.0	●	●	●			
R/L 050.3-10	0.1	0.6	2.6	24	10	0.2	2.8	4.0	●	●	●			
R/L 050.3-16	0.1	0.6	2.6	30	16	0.2	2.8	4.0	●	●	●			
R/L 050.3-20	0.1	0.6	2.6	34	20	0.2	2.8	4.0	●	●	●			
R/L 050.35-10	0.1	1.1	3.1	24	10	0.25	3.5	4.0	●	●	●			
R/L 050.35-16	0.1	1.1	3.1	30	16	0.25	3.5	4.0	●	●	●			
R/L 050.35-20	0.1	1.1	3.1	34	20	0.25	3.5	4.0	●	●	●			
R/L 050.35-24	0.1	1.1	3.1	38	24	0.25	3.5	4.0		●	●			
↳ ...														

Weitere HM Sorten können Sie in der Sortenübersicht im Kapitel "Technische Hinweise" und der Preisliste finden.

Bestellbeispiel:  
für rechte Ausführung und Sorte  
R050.25-5/AL41F

More carbide grades you can find in the grades summary in the chapter "technical instructions" and in the price list.

order-example:  
righthand version and grade  
R050.25-5/AL41F



# ULTRAMINI

Bohrungsbearbeitung  
ab  $\varnothing$  0.2 mm

grooving, boring and profiling  
starting at  $\varnothing$  0.2 mm

# Typ 050

Audreihen und Kopieren

D min. 0.2 - 9.8 mm

boring and profiling

D min. 0.2 - 9.8 mm

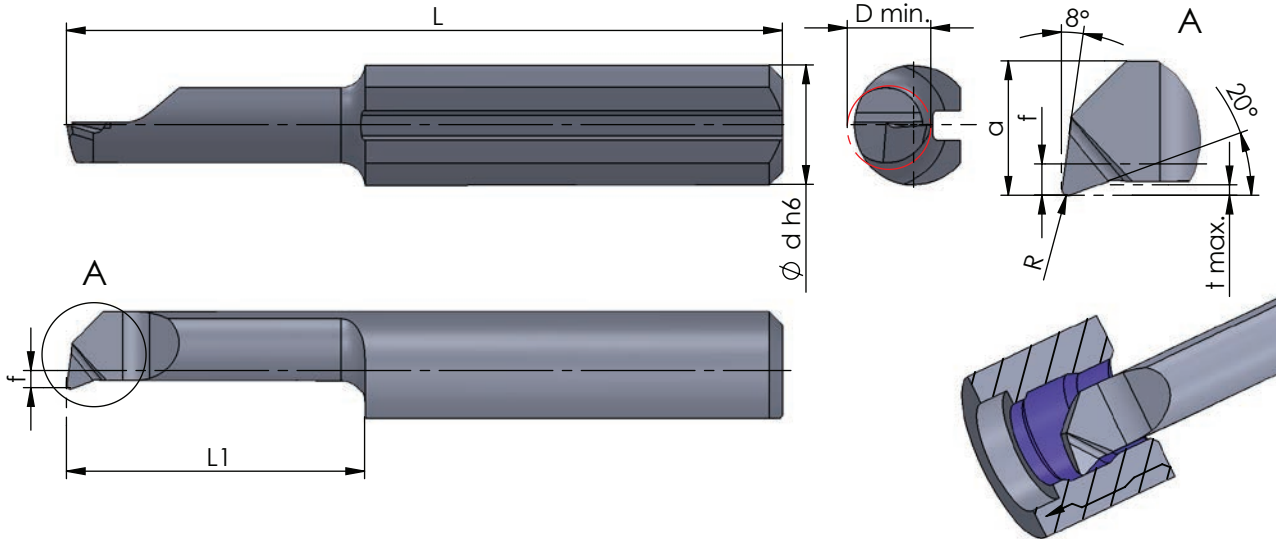

Rechts (R): wie gezeichnet  
Links (L): spiegelbildlich

righthand (R): as shown  
lefthand version (L): mirror image

Abmessungen in mm

dimensions in mm

Bestellnummer part number	R	f	a	L	L1	t max.	D min.	Ø d h6	K10F CN45F AL41F PD2F	Klemmhalter Typ toolholder type
R/L 050.4-10	0.1	1.5	3.5	24	10	0.3	4.0	4.0	● ● ●	640, ... ...4
R/L 050.4-16	0.1	1.5	3.5	30	16	0.3	4.0	4.0	● ● ●	
R/L 050.4-20	0.1	1.5	3.5	34	20	0.3	4.0	4.0	● ● ●	
R/L 050.4-24	0.1	1.5	3.5	38	24	0.3	4.0	4.0	● ● ●	
R/L 050.4-28	0.1	1.5	3.5	42	28	0.3	4.0	4.0	● ●	
R/L 050.5-10	0.15	1.9	4.4	25	10	0.5	5.0	5.0	● ● ●	645, ... 650, ... ...5
R/L 050.5-15	0.15	1.9	4.4	30	15	0.5	5.0	5.0	● ● ●	
R/L 050.5-20	0.15	1.9	4.4	35	20	0.5	5.0	5.0	● ● ●	
R/L 050.5-25	0.15	1.9	4.4	40	25	0.5	5.0	5.0	● ● ●	
R/L 050.5-30	0.15	1.9	4.4	45	30	0.5	5.0	5.0	● ● ●	
R/L 050.5-35	0.15	1.9	4.4	50	35	0.5	5.0	5.0	● ●	
R/L 050.5-40	0.15	1.9	4.4	55	40	0.5	5.0	5.0	● ●	
↳ ...										

Weitere HM Sorten können Sie in der Sortenübersicht im Kapitel "Technische Hinweise" und der Preisliste finden.

Bestellbeispiel:  
für rechte Ausführung und Sorte  
R050.4-10/AL41F

More carbide grades you can find in the grades summary in the chapter "technical instructions" and in the price list.

order-example:  
righthand version and grade  
R050.4-10/AL41F





**ULTRAMINI**

Bohrungsbearbeitung  
ab  $\varnothing$  0.2 mm

grooving, boring and profiling  
starting at  $\varnothing$  0.2 mm

**Typ 050**

Audreihen und Kopieren

D min. 0.2 - 9.8 mm

boring and profiling

D min. 0.2 - 9.8 mm

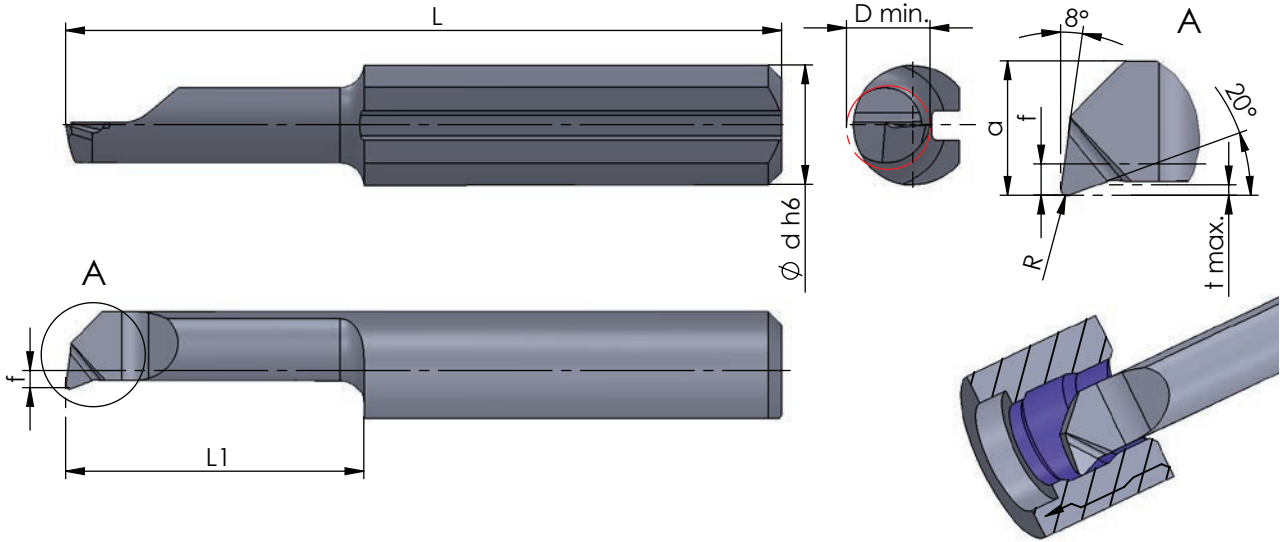

Rechts (R): wie gezeichnet  
Links (L): spiegelbildlich

righthand (R): as shown  
lefthand version (L): mirror image

Abmessungen in mm

dimensions in mm

Bestellnummer part number	R	f	a	L	L1	t max.	D min.	$\varnothing d h6$	K10F	CN45F	AL41F	PD2F	Klemmhalter Typ toolholder type	
														660... ...6
...														
R/L 050.6-15	0.15	2.3	5.3	30	15	0.5	6.0	6.0	●	●	●		676... 670... 687... ...7	
R/L 050.6-22	0.15	2.3	5.3	37	22	0.5	6.0	6.0	●	●	●			
R/L 050.6-25	0.15	2.3	5.3	40	25	0.5	6.0	6.0	●	●	●			
R/L 050.6-30	0.15	2.3	5.3	45	30	0.5	6.0	6.0	●	●	●			
R/L 050.6-35	0.15	2.3	5.3	50	35	0.5	6.0	6.0		●	●			
R/L 050.6-42	0.15	2.3	5.3	57	42	0.5	6.0	6.0		●	●			
R/L 050.7-20	0.15	2.8	6.3	35	20	0.6	6.8	7.0	●	●	●		676... 670... 687... ...7	
R/L 050.7-25	0.15	2.8	6.3	40	25	0.6	6.8	7.0	●	●	●			
R/L 050.7-30	0.15	2.8	6.3	45	30	0.6	6.8	7.0	●	●	●			
R/L 050.7-35	0.15	2.8	6.3	50	35	0.6	6.8	7.0		●	●			
R/L 050.7-40	0.15	2.8	6.3	55	40	0.6	6.8	7.0		●	●			
R/L 050.7-45	0.15	2.8	6.3	60	45	0.6	6.8	7.0	●	●	●			
R/L 050.7-50	0.15	2.8	6.3	65	50	0.6	6.8	7.0		●	●			
↳ ...														

Weitere HM Sorten können Sie in der Sortenübersicht im Kapitel "Technische Hinweise" und der Preisliste finden.

Bestellbeispiel:  
für rechte Ausführung und Sorte  
R050.6-15/AL41F

More carbide grades you can find in the grades summary in the chapter "technical instructions" and in the price list.

order-example:  
righthand version and grade  
R050.6-15/AL41F



# ULTRAMINI

Bohrungsbearbeitung  
ab  $\varnothing 0.2$  mm

grooving, boring and profiling  
starting at  $\varnothing 0.2$  mm

# Typ 050

Audreihen und Kopieren

D min. 0.2 - 9.8 mm

boring and profiling

D min. 0.2 - 9.8 mm

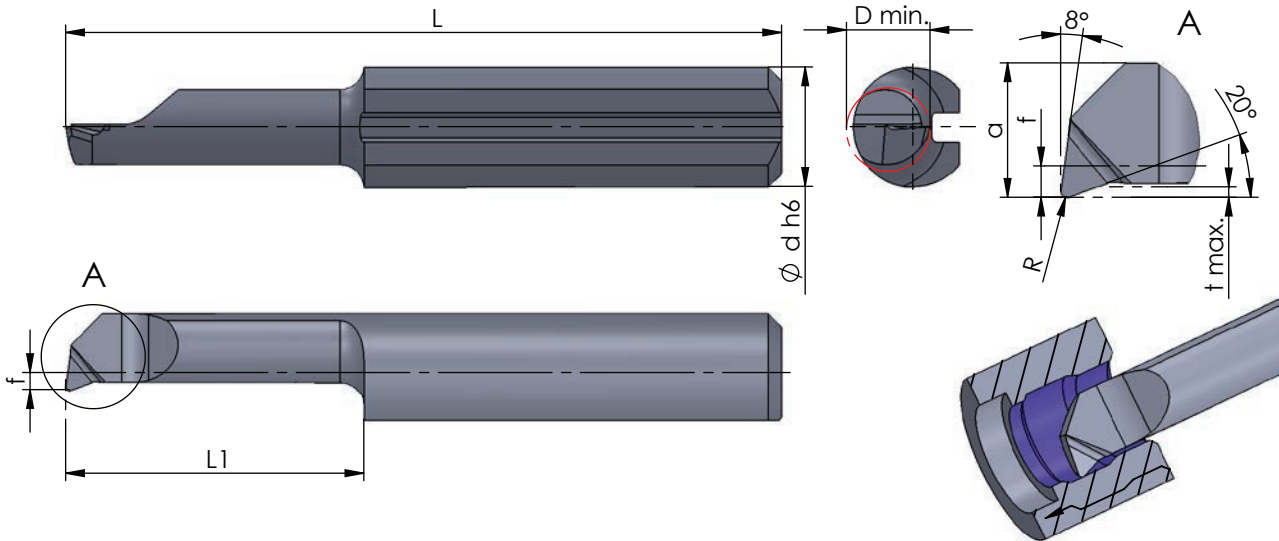

Rechts (R): wie gezeichnet  
Links (L): spiegelbildlich

righthand (R): as shown  
lefthand version (L): mirror image

Abmessungen in mm

dimensions in mm

Bestellnummer part number	R	f	a	L	L1	t max.	D min.	$\varnothing$ d h6					Klemmhalter Typ toolholder type	
									K10F	CN45F	AL41F	PD2F		
...														
R/L 050.8-50	0.2	3.3	7.3	70	50	0.7	7.8	8.0			●		681...	680... 687... ...8
R/L 050.8-60	0.2	3.3	7.3	80	60	0.7	7.8	8.0			●		681...	680... 687... ...8
R/L 050.10-35	0.2	4.2	9.2	60	35	1.0	9.8	10.0			●		681...	680... 687... ...8

Weitere HM Sorten können Sie in der Sortenübersicht im Kapitel "Technische Hinweise" und der Preisliste finden.

Bestellbeispiel:  
für rechte Ausführung und Sorte  
R050.8-50/AL41F

More carbide grades you can find in the grades summary in the chapter "technical instructions" and in the price list.

order-example:  
righthand version and grade  
R050.8-50/AL41F



## ULTRAMINI

Bohrungsbearbeitung  
ab  $\varnothing 0.2$  mm

grooving, boring and profiling  
starting at  $\varnothing 0.2$  mm

## Superfinish Typ F050

Superfinish Ausdrehen für  
perfekte Oberflächen

D min. 4.0 - 6.8 mm

Superfinish boring for  
perfect surface quality

D min. 4.0 - 6.8 mm

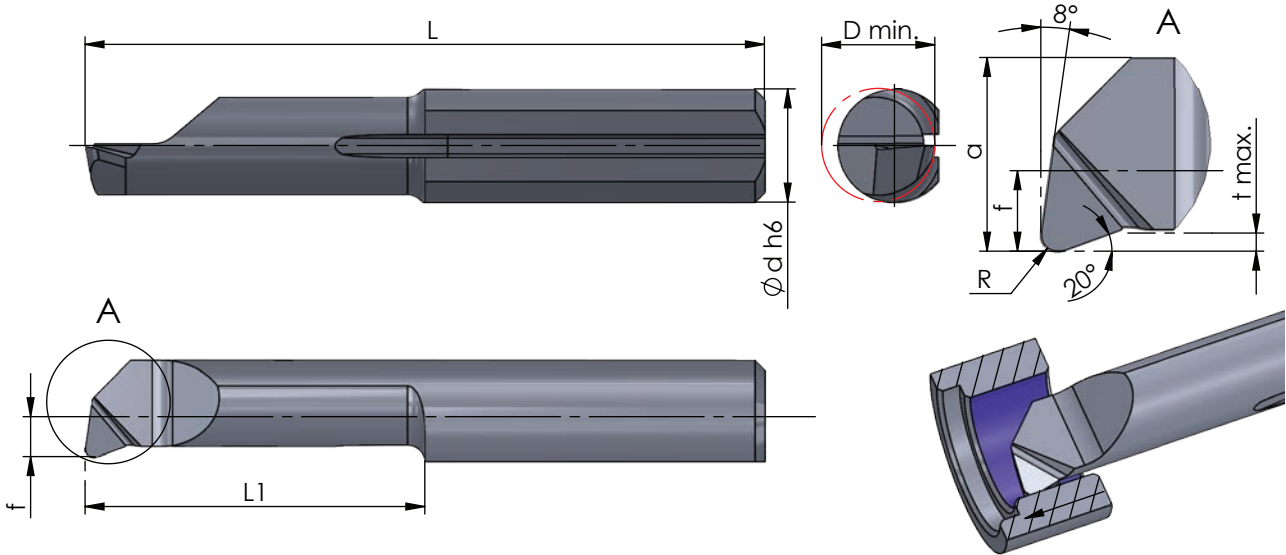

Rechts (R): wie gezeichnet  
Links (L): spiegelbildlich

righthand (R): as shown  
lefthand version (L): mirror image

Abmessungen in mm

dimensions in mm

	Bestellnummer part number	R	f	a	L	L1	t max.	D min.	$\varnothing$ d h6	K10F	CN45F	AL41F	P18C-NH	Klemmhalter Typ	toolholder type
neu	R/L F050.4-10	0.4	1.35	3.35	24	10	0.25	4.0	4.0					645, ...	640, ... ...4
neu	R/L F050.4-20	0.4	1.35	3.35	34	20	0.25	4.0	4.0						
neu	R/L F050.5-15	0.4	1.80	4.30	30	15	0.40	5.0	5.0					645, ...	650, ... ...5
neu	R/L F050.5-25	0.4	1.80	4.30	40	25	0.40	5.0	5.0						
neu	R/L F050.6-15	0.4	2.20	5.20	30	15	0.50	6.0	6.0					676, ...	660, ... ...6
neu	R/L F050.6-30	0.4	2.20	5.20	45	30	0.50	6.0	6.0						
neu	R/L F050.7-20	0.4	2.70	6.20	35	20	0.50	7.0	6.8					676, ...	670, ... 687, ... ...7
neu	R/L F050.7-35	0.4	2.70	6.20	50	35	0.50	7.0	6.8						

Weitere HM Sorten können Sie in der Sortenübersicht im Kapitel "Technische Hinweise" und der Preisliste finden.

Bestellbeispiel:  
für rechte Ausführung und Sorte  
RF050.4-10/P18C-NH

### weitere Informationen:

- siehe Allgemeine Beschreibung

### more informations:

- look at the general instructions

More carbide grades you can find in the grades summary in the chapter "technical instructions" and in the price list.

order-example:  
righthand version and grade  
RF050.4-10/P18C-NH

**BROTECH**

# ULTRAMINI

Bohrungsbearbeitung  
ab  $\varnothing 0.2$  mm

grooving, boring and profiling  
starting at  $\varnothing 0.2$  mm

# Typ 050.20

Ausdrehen und Kopieren  
mit Geometrie  $20^\circ / 20^\circ$

boring and profiling  
with geometry  $20^\circ / 20^\circ$

D min. 2.0 - 5.0 mm

D min. 2.0 - 5.0 mm

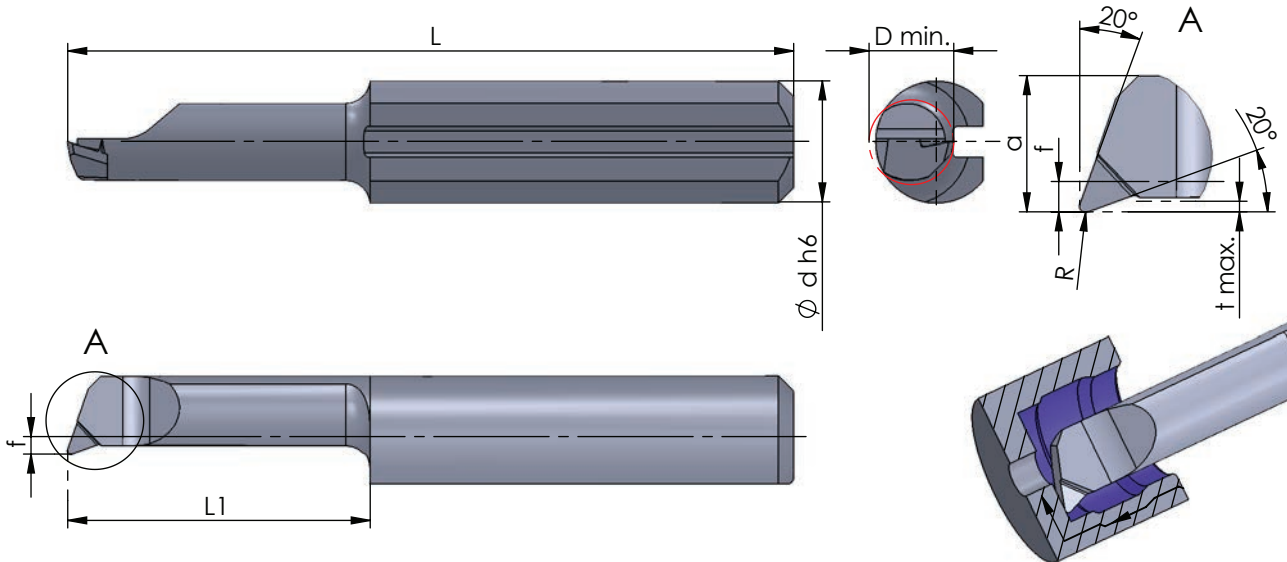

Rechts (R): wie gezeichnet  
Links (L): spiegelbildlich

righthand (R): as shown  
lefthand version (L): mirror image

Abmessungen in mm

dimensions in mm

Bestellnummer part number	R	f	a	L	L1	t max.	D min.	Ø d h6	K10F CN45F AL41F PD2F	Klemmhalter Typ toolholder type
R/L 050.20.2-5	0.05		1.7	19	5	0.1	2.0	4.0	●	645... 640... ...4
R/L 050.20.2-10	0.05		1.7	24	10	0.1	2.0	4.0	●	
R/L 050.20.2-15	0.05		1.7	29	15	0.1	2.0	4.0	●	
R/L 050.20.3-10	0.1	0.6	2.6	24	10	0.2	2.8	4.0	●	
R/L 050.20.3-16	0.1	0.6	2.6	30	16	0.2	2.8	4.0	●	
R/L 050.20.3-20	0.1	0.6	2.6	34	20	0.2	2.8	4.0	●	
R/L 050.20.4-10	0.1	1.5	3.5	24	10	0.3	4.0	4.0	●	
R/L 050.20.4-16	0.1	1.5	3.5	30	16	0.3	4.0	4.0	●	
R/L 050.20.4-20	0.1	1.5	3.5	34	20	0.3	4.0	4.0	●	
R/L 050.20.4-24	0.1	1.5	3.5	38	24	0.3	4.0	4.0	●	
R/L 050.20.4-28	0.1	1.5	3.5	42	28	0.3	4.0	4.0	●	
R/L 050.20.5-10	0.15	1.9	4.4	25	10	0.5	5.0	5.0	●	650... ...5
R/L 050.20.5-20	0.15	1.9	4.4	35	20	0.5	5.0	5.0	●	
R/L 050.20.5-35	0.15	1.9	4.4	50	35	0.5	5.0	5.0	●	

Weitere HM Sorten können Sie in der Sortenübersicht im Kapitel "Technische Hinweise" und der Preisliste finden.

Bestellbeispiel:  
für rechte Ausführung und Sorte  
R050.20.2-5/AL41F

More carbide grades you can find in the grades summary in the chapter "technical instructions" and in the price list.

order-example:  
righthand version and grade  
R050.20.2-5/AL41F



**ULTRAMINI**

Bohrungsbearbeitung  
ab  $\varnothing 0.2$  mm

grooving, boring and profiling  
starting at  $\varnothing 0.2$  mm

**Typ 053**

Audreihen und Kopieren  
mit Eckenradius 0.03 mm

boring and profiling  
with corner radius 0.03 mm

D min. 2.8 - 4.0 mm

D min. 2.8 - 4.0 mm

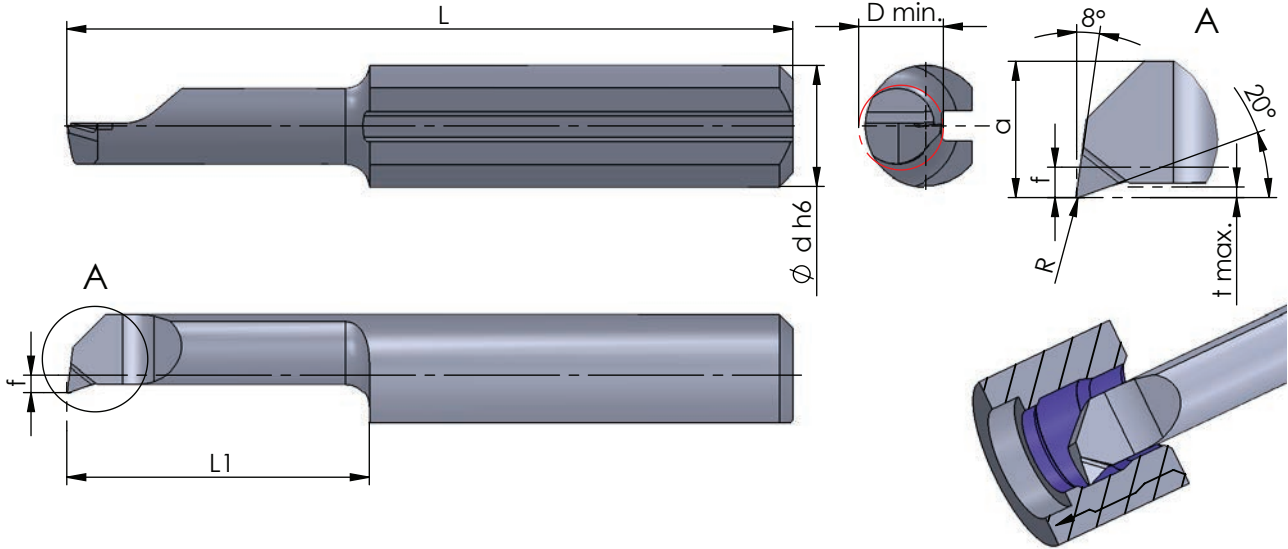

Rechts (R): wie gezeichnet  
Links (L): spiegelbildlich

righthand (R): as shown  
lefthand version (L): mirror image

Abmessungen in mm

dimensions in mm

Bestellnummer part number	R	f	a	L	L1	t max.	D min.	Ø d h6	Klemmhalter Typ toolholder type				
									K10F	CN45F	AL41F	PD2F	
R/L 053.3-10	0.03	0.6	2.6	24	10	0.2	2.8	4.0			●		
R/L 053.3-16	0.03	0.6	2.6	30	16	0.2	2.8	4.0			●		
R/L 053.3-20	0.03	0.6	2.6	34	20	0.2	2.8	4.0			●		
R/L 053.4-10	0.03	1.5	3.5	24	10	0.3	4.0	4.0			●		
R/L 053.4-16	0.03	1.5	3.5	30	16	0.3	4.0	4.0			●		
R/L 053.4-20	0.03	1.5	3.5	34	20	0.3	4.0	4.0			●		
R/L 053.4-24	0.03	1.5	3.5	38	24	0.3	4.0	4.0			●		
R/L 053.4-28	0.03	1.5	3.5	42	28	0.3	4.0	4.0			●		

Weitere HM Sorten können Sie in der Sortenübersicht im Kapitel "Technische Hinweise" und der Preisliste finden.

Bestellbeispiel:  
für rechte Ausführung und Sorte  
R053.3-10/AL41F

More carbide grades you can find in the grades summary in the chapter "technical instructions" and in the price list.

order-example:  
righthand version and grade  
R053.3-10/AL41F



# ULTRAMINI

Bohrungsbearbeitung  
ab  $\varnothing 0.2$  mm

grooving, boring and profiling  
starting at  $\varnothing 0.2$  mm

# Typ 055

Ausdrehen und Kopieren  
mit Eckenradius 0.05 mm

boring and profiling  
with corner radius 0.05 mm

D min. 2.0 - 6.0 mm

D min. 2.0 - 6.0 mm

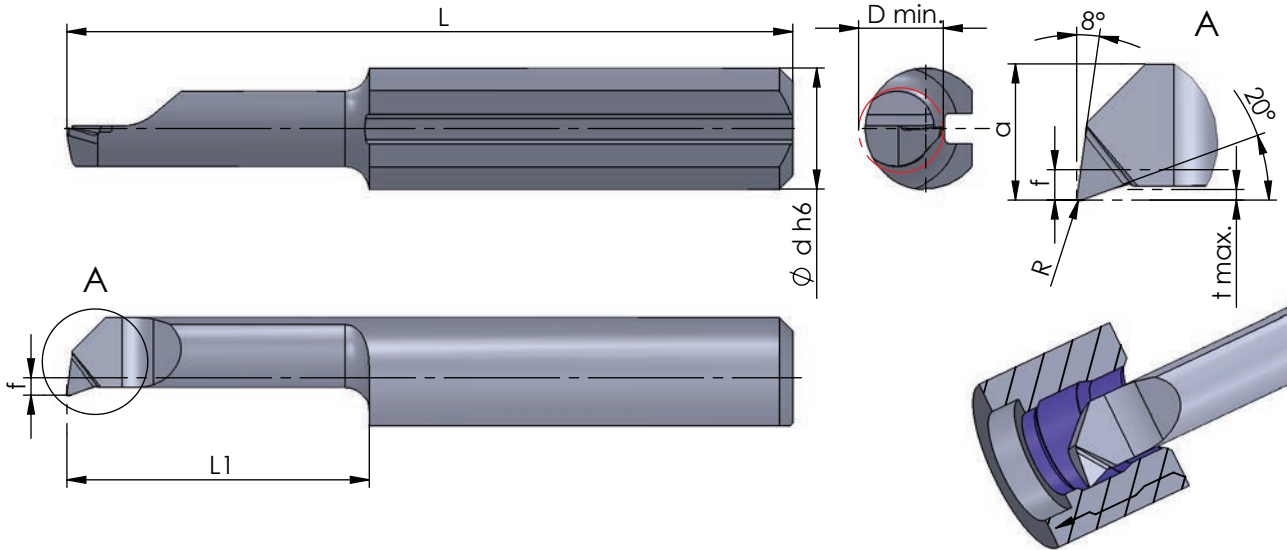

Rechts (R): wie gezeichnet  
Links (L): spiegelbildlich

righthand (R): as shown  
lefthand version (L): mirror image

Abmessungen in mm

dimensions in mm

Bestellnummer part number	R	f	a	L	L1	t max.	D min.	Ø d h6	Klemmhalter Typ toolholder type				
									K10F	CN45F	AL41F	PD2F	
R/L 055.2-5	0.05		1.7	19	5	0.1	2.0	4.0			●		
R/L 055.2-10	0.05		1.7	24	10	0.1	2.0	4.0			●		
R/L 055.2-15	0.05		1.7	29	15	0.1	2.0	4.0			●		
R/L 055.3-10	0.05	0.6	2.6	24	10	0.2	2.8	4.0			●		
R/L 055.3-16	0.05	0.6	2.6	30	16	0.2	2.8	4.0			●		
R/L 055.3-20	0.05	0.6	2.6	34	20	0.2	2.8	4.0			●		
R/L 055.4-10	0.05	1.5	3.5	24	10	0.3	4.0	4.0			●		
R/L 055.4-16	0.05	1.5	3.5	30	16	0.3	4.0	4.0			●		
R/L 055.4-20	0.05	1.5	3.5	34	20	0.3	4.0	4.0			●		
R/L 055.4-24	0.05	1.5	3.5	38	24	0.3	4.0	4.0			●		
R/L 055.4-28	0.05	1.5	3.5	42	28	0.3	4.0	4.0			●		
↳ ...													

Weitere HM Sorten können Sie in der Sortenübersicht im Kapitel "Technische Hinweise" und der Preisliste finden.

Bestellbeispiel:  
für rechte Ausführung und Sorte  
R055.2-5/AL41F

More carbide grades you can find in the grades summary in the chapter "technical instructions" and in the price list.

order-example:  
righthand version and grade  
R055.2-5/AL41F



**ULTRAMINI**

Bohrungsbearbeitung  
ab  $\varnothing$  0.2 mm

grooving, boring and profiling  
starting at  $\varnothing$  0.2 mm

**Typ 055**

Ausdrehen und Kopieren  
mit Eckenradius 0.05 mm

boring and profiling  
with corner radius 0.05 mm

D min. 2.0 - 6.0 mm

D min. 2.0 - 6.0 mm

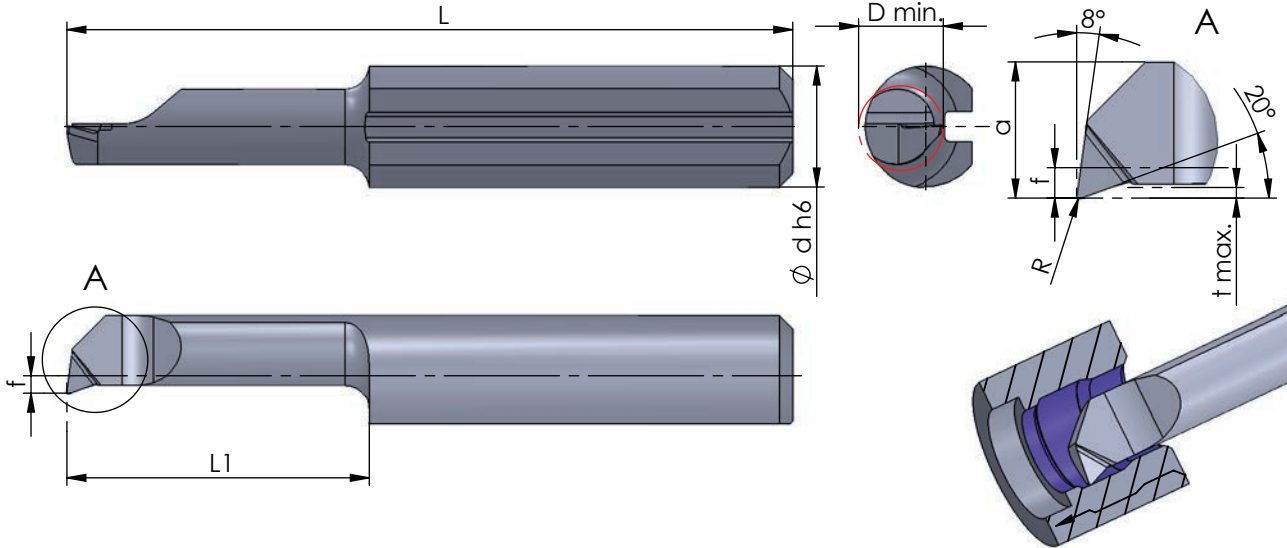

Rechts (R): wie gezeichnet  
Links (L): spiegelbildlich

righthand (R): as shown  
lefthand version (L): mirror image

Abmessungen in mm

dimensions in mm

Bestellnummer part number	R	f	a	L	L1	t max.	D min.	Ø d h6	K10F CN45F AL41F PD2F	Klemmhalter Typ toolholder type	
...											
R/L 055.5-10	0.05	1.9	4.4	25	10	0.5	5.0	5.0		●	
R/L 055.5-15	0.05	1.9	4.4	30	15	0.5	5.0	5.0		●	
R/L 055.5-20	0.05	1.9	4.4	35	20	0.5	5.0	5.0		●	
R/L 055.5-25	0.05	1.9	4.4	40	25	0.5	5.0	5.0		●	645... 650... ...5
R/L 055.5-30	0.05	1.9	4.4	45	30	0.5	5.0	5.0		●	
R/L 055.5-35	0.05	1.9	4.4	50	35	0.5	5.0	5.0		●	
R/L 055.6-15	0.05	2.3	5.3	30	15	0.5	6.0	6.0		●	
R/L 055.6-22	0.05	2.3	5.3	37	22	0.5	6.0	6.0		●	
R/L 055.6-25	0.05	2.3	5.3	40	25	0.5	6.0	6.0		●	
R/L 055.6-30	0.05	2.3	5.3	45	30	0.5	6.0	6.0		●	
R/L 055.6-35	0.05	2.3	5.3	50	35	0.5	6.0	6.0		●	660... 676... ...6
R/L 055.6-42	0.05	2.3	5.3	57	42	0.5	6.0	6.0		●	

Weitere HM Sorten können Sie in der Sortenübersicht im Kapitel "Technische Hinweise" und der Preisliste finden.

Bestellbeispiel:  
für rechte Ausführung und Sorte  
R055.5-10/AL41F

More carbide grades you can find in the grades summary in the chapter "technical instructions" and in the price list.

order-example:  
righthand version and grade  
R055.5-10/AL41F



## ULTRAMINI

Bohrungsbearbeitung  
ab  $\varnothing 0.2 \text{ mm}$

grooving, boring and profiling  
starting at  $\varnothing 0.2 \text{ mm}$

## Typ 050....B

Ausdrehen und Kopieren  
mit innerer Kühlmittelzufuhr

boring and profiling  
with through coolant

D min. 6.0 - 6.8 mm  
Auskrägung (L1) bis 7x D

D min. 6.0 - 6.8 mm  
overhang length (L1) up to 7x D

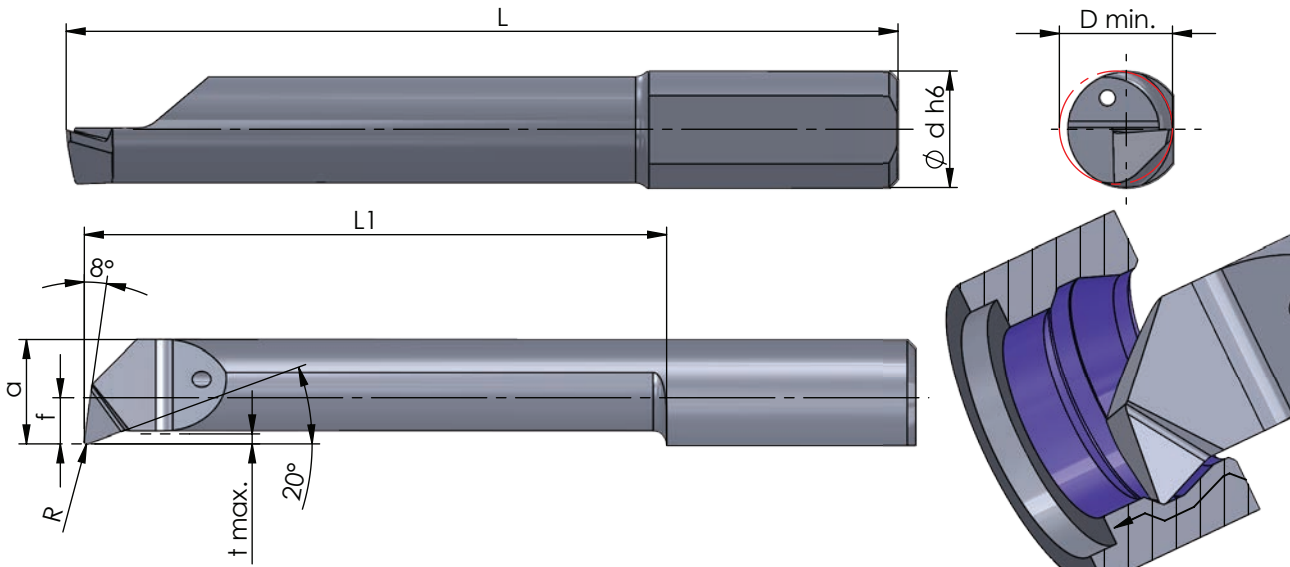

Rechts (R): wie gezeichnet  
Links (L): spiegelbildlich

righthand (R): as shown  
lefthand version (L): mirror image

Abmessungen in mm

dimensions in mm

Bestellnummer part number	R	f	a	L	L1	t max.	D min.	Ø d h6					Klemmhalter Typ toolholder type	
									K10F	CN45F	AL41F	PD2F		
R/L 050.6-35B	0.15	2.3	5.3	50	35	0.5	6.0	6.0			●			
R/L 050.6-42B	0.15	2.3	5.3	57	42	0.5	6.0	6.0			●		660... ...6	
R/L 050.7-35B	0.15	2.8	6.3	50	35	0.6	6.8	7.0			●	676...		
R/L 050.7-40B	0.15	2.8	6.3	55	40	0.6	6.8	7.0			●			
R/L 050.7-45B	0.15	2.8	6.3	60	45	0.6	6.8	7.0			●			670... 687... ...7
R/L 050.7-50B	0.15	2.8	6.3	65	50	0.6	6.8	7.0			●			

Weitere HM Sorten können Sie in der Sortenübersicht im Kapitel "Technische Hinweise" und der Preisliste finden.

Bestellbeispiel:  
für rechte Ausführung und Sorte  
R050.6-35B/AL41F

More carbide grades you can find in the grades summary in the chapter "technical instructions" and in the price list.

order-example:  
righthand version and grade  
R050.6-35B/AL41F



**ULTRAMINI**

Bohrungsbearbeitung  
ab  $\varnothing$  0.2 mm

grooving, boring and profiling  
starting at  $\varnothing$  0.2 mm

**Typ 050....C**

Ausdrehen und Kopieren  
mit Spantreppe  
für bessere Spantkontrolle

boring and profiling  
with chipbreaker  
for better chipcontrol

D min. 2.0 - 6.8 mm  
Auskrägung (L1) bis 7x D

D min. 2.0 - 6.8 mm  
overhang length (L1) up to 7x D

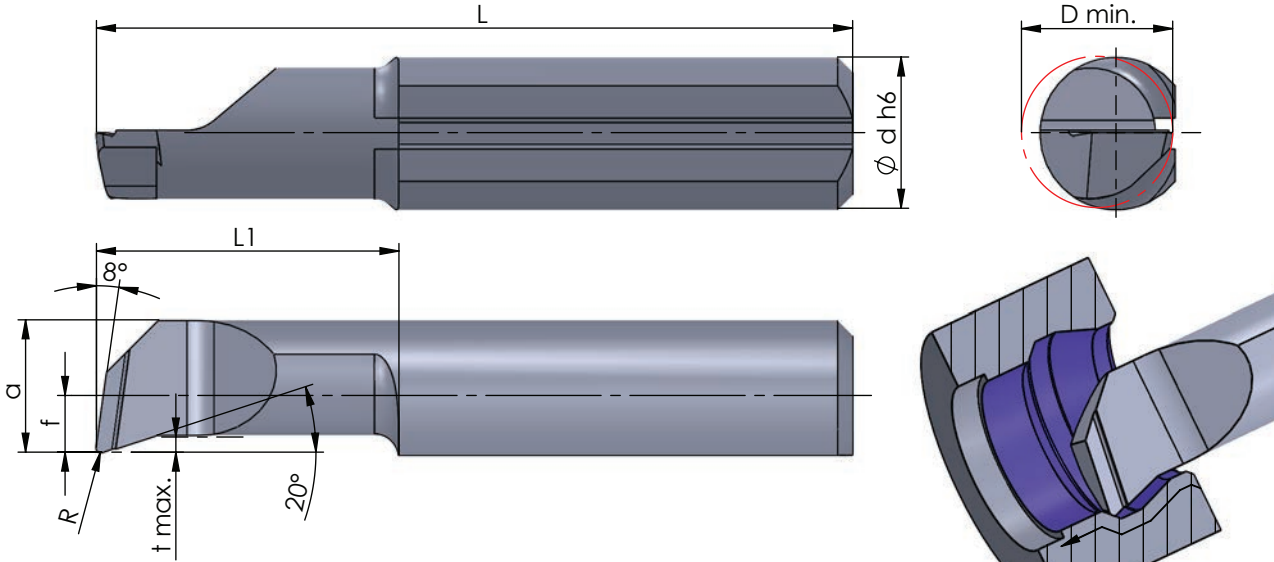

Rechts (R): wie gezeichnet  
Links (L): spiegelbildlich

righthand (R): as shown  
lefthand version (L): mirror image

Abmessungen in mm

dimensions in mm

Bestellnummer part number	R	f	a	L	L1	t max.	D min.	Ø d h6	K10F CN45F AL41F PD2F	Klemmhalter Typ toolholder type
R/L 050.2-10C	0.05		1.7	24	10	0.1	2.0	4.0	●	645... 640... ...4
R/L 050.3-10C	0.1	0.6	2.6	24	10	0.2	2.8	4.0	●	
R/L 050.3-16C	0.1	0.6	2.6	30	16	0.2	2.8	4.0	●	
R/L 050.4-10C	0.1	1.5	3.5	24	10	0.3	4.0	4.0	●	
R/L 050.4-16C	0.1	1.5	3.5	30	16	0.3	4.0	4.0	●	
R/L 050.4-20C	0.1	1.5	3.5	34	20	0.3	4.0	4.0	●	
R/L 050.4-24C	0.1	1.5	3.5	38	24	0.3	4.0	4.0	●	
R/L 050.4-28C	0.1	1.5	3.5	42	28	0.3	4.0	4.0	●	650... ...5
R/L 050.5-10C	0.15	1.9	4.4	25	10	0.5	5.0	5.0	●	
R/L 050.5-15C	0.15	1.9	4.4	30	15	0.5	5.0	5.0	● ●	
R/L 050.5-20C	0.15	1.9	4.4	35	20	0.5	5.0	5.0	●	
R/L 050.5-25C	0.15	1.9	4.4	40	25	0.5	5.0	5.0	●	
R/L 050.5-30C	0.15	1.9	4.4	45	30	0.5	5.0	5.0	●	
R/L 050.5-35C	0.15	1.9	4.4	50	35	0.5	5.0	5.0	●	

Weitere HM Sorten können Sie in der Sortenübersicht im Kapitel "Technische Hinweise" und der Preisliste finden.

Bestellbeispiel:  
für rechte Ausführung und Sorte  
R050.2-10C/AL41F

More carbide grades you can find in the grades summary in the chapter "technical instructions" and in the price list.

order-example:  
righthand version and grade  
R050.2-10C/AL41F



# ULTRAMINI

Bohrungsbearbeitung  
ab  $\varnothing 0.2 \text{ mm}$

grooving, boring and profiling  
starting at  $\varnothing 0.2 \text{ mm}$

# Typ 050....C

Ausdrehen und Kopieren  
mit Spantreppe  
für bessere Spantkontrolle

boring and profiling  
with chipbreaker  
for better chipcontrol

D min. 2.0 - 6.8 mm  
Auskrägung (L1) bis 7x D

D min. 2.0 - 6.8 mm  
overhang length (L1) up to 7x D

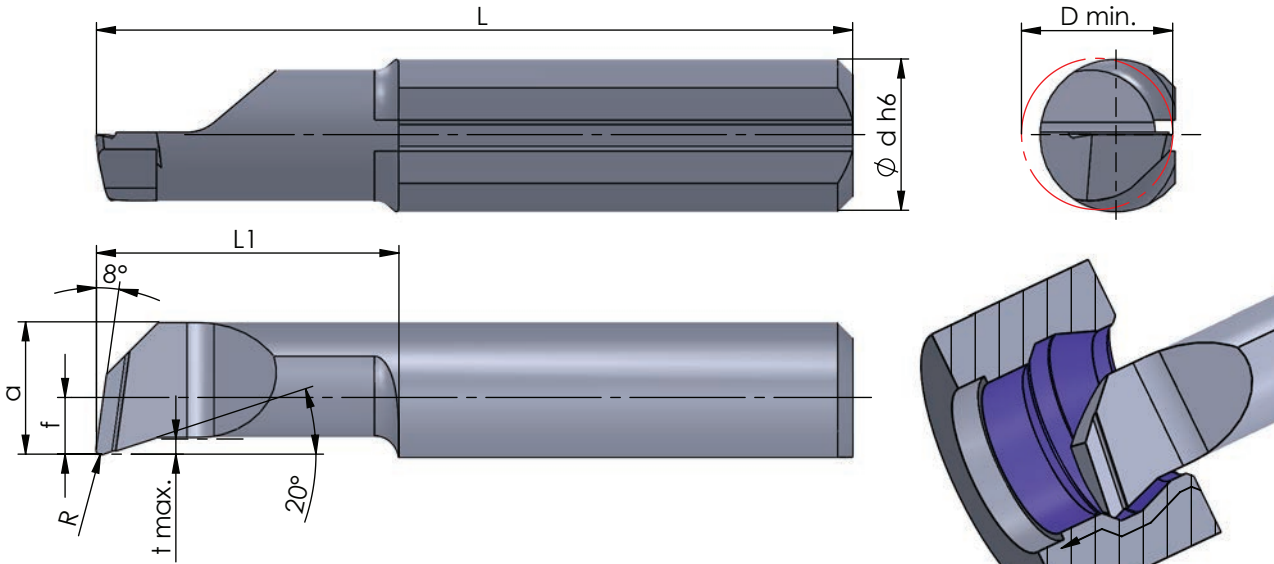

Rechts (R): wie gezeichnet  
Links (L): spiegelbildlich

righthand (R): as shown  
lefthand version (L): mirror image

Abmessungen in mm

dimensions in mm

Bestellnummer part number	R	f	a	L	L1	t max.	D min.	Ø d h6	K10F CN45F AL41F PD2F	Klemmhalter Typ toolholder type	
										676... 670... 687... ...7	660... ...6
R/L 050.6-15C	0.15	2.3	5.3	30	15	0.5	6.0	6.0		●	676... 660... ...6
R/L 050.6-22C	0.15	2.3	5.3	37	22	0.5	6.0	6.0		●	
R/L 050.6-25C	0.15	2.3	5.3	40	25	0.5	6.0	6.0		●	
R/L 050.6-30C	0.15	2.3	5.3	45	30	0.5	6.0	6.0		●	
R/L 050.6-35C	0.15	2.3	5.3	50	35	0.5	6.0	6.0		●	
R/L 050.6-42C	0.15	2.3	5.3	57	42	0.5	6.0	6.0		●	
R/L 050.7-20C	0.15	2.8	6.3	35	20	0.6	6.8	7.0		●	676... 670... 687... ...7
R/L 050.7-25C	0.15	2.8	6.3	40	25	0.6	6.8	7.0		●	
R/L 050.7-30C	0.15	2.8	6.3	45	30	0.6	6.8	7.0		●	
R/L 050.7-35C	0.15	2.8	6.3	50	35	0.6	6.8	7.0		●	
R/L 050.7-40C	0.15	2.8	6.3	55	40	0.6	6.8	7.0		●	
R/L 050.7-45C	0.15	2.8	6.3	60	45	0.6	6.8	7.0		●	
R/L 050.7-50C	0.15	2.8	6.3	65	50	0.6	6.8	7.0		●	

Weitere HM Sorten können Sie in der Sortenübersicht im Kapitel "Technische Hinweise" und der Preisliste finden.

Bestellbeispiel:  
für rechte Ausführung und Sorte  
R050.6-15C/AL41F

More carbide grades you can find in the grades summary in the chapter "technical instructions" and in the price list.

order-example:  
righthand version and grade  
R050.6-15C/AL41F



## ULTRAMINI

Bohrungsbearbeitung  
ab  $\varnothing 0.2$  mm

grooving, boring and profiling  
starting at  $\varnothing 0.2$  mm

## Mediline Typ M050

Audreihen und Kopieren  
mit innerer Kühlmittelzufuhr  
und modifizierter Geometrie

boring and profiling  
with through coolant  
and modified profile

D min. 0.5 - 4.0 mm

D min. 0.5 - 4.0 mm

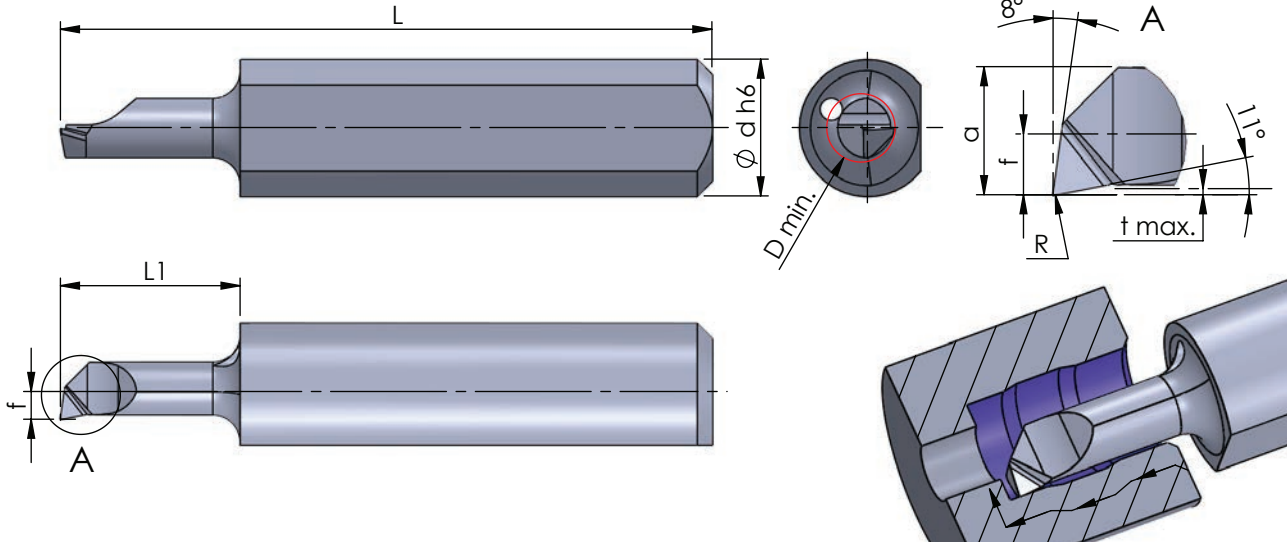

Rechts (R): wie gezeichnet  
Links (L): spiegelbildlich

righthand (R): as shown  
lefthand version (L): mirror image

Abmessungen in mm

dimensions in mm

Bestellnummer part number	R	f	a	L	L1	t max.	D min.	$\varnothing$ d h6	K10F	CN45F	AL41F	P07C	Klemmhalter Typ	toolholder type
R/L M050.05-2	0.02	0.2	0.4	20	2	0.02	0.5	4.0	●			●	640... 645... ...4	
R/L M050.08-4	0.02	0.35	0.7	20	4	0.03	0.8	4.0	●			●		
R/L M050.1-5	0.02	0.4	0.9	20	5	0.05	1	4.0	●			●		
R/L M050.1-7	0.02	0.4	0.9	22	7	0.05	1	4.0	●			●		
R/L M050.15-5	0.02	0.6	1.35	19	5	0.08	1.5	4.0	●			●		
R/L M050.15-10	0.02	0.6	1.35	24	10	0.08	1.5	4.0	●			●		
R/L M050.2-5	0.02	0.8	1.7	19	5	0.08	2	4.0	●			●		
R/L M050.2-10	0.02	0.8	1.7	24	10	0.08	2	4.0	●			●		
↳ ...														

Weitere HM Sorten können Sie in der Sortenübersicht im Kapitel "Technische Hinweise" und der Preisliste finden.

Bestellbeispiel:  
für rechte Ausführung und Sorte  
RM050.05-2/P07C

### weitere Informationen:

- siehe Allgemeine Beschreibung

### more informations:

- look at the general instructions

More carbide grades you can find in the grades summary in the chapter "technical instructions" and in the price list.

order-example:  
righthand version and grade  
RM050.05-2/P07C

**BROTECH**

## ULTRAMINI

Bohrungsbearbeitung  
ab  $\varnothing 0.2$  mm

grooving, boring and profiling  
starting at  $\varnothing 0.2$  mm

## Mediline Typ M050

Audreihen und Kopieren  
mit innerer Kühlmittelzufuhr  
und modifizierter Geometrie

boring and profiling  
with through coolant  
and modified profile

D min. 0.5 - 4.0 mm

D min. 0.5 - 4.0 mm

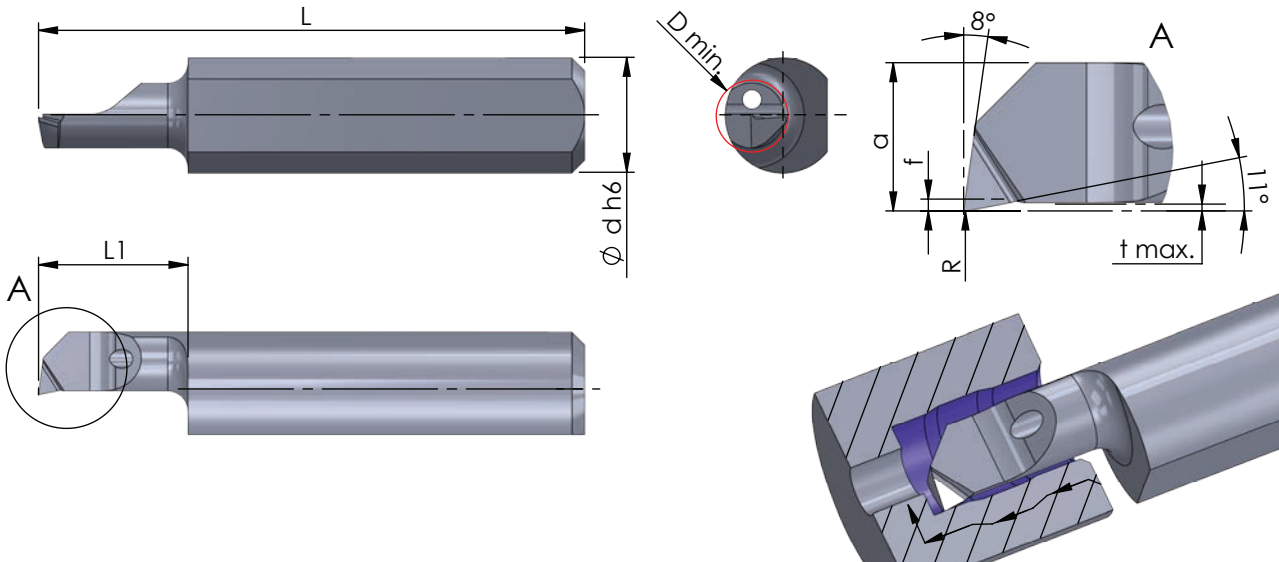

Rechts (R): wie gezeichnet  
Links (L): spiegelbildlich

righthand (R): as shown  
lefthand version (L): mirror image

Abmessungen in mm

dimensions in mm

Bestellnummer part number	R	f	a	L	L1	t max.	D min.	Ø d h6					Klemmhalter Typ toolholder type
									K10F	CN45F	AL41F	P07C	
...													
R/L M050.25-5	0.02	0.2	2.2	19	5	0.1	2.5	4.0	●			●	640... 645... ...4
R/L M050.25-10	0.02	0.2	2.2	24	10	0.1	2.5	4.0	●			●	
R/L M050.3-10	0.02	0.6	2.6	24	10	0.15	3	4.0	●			●	
R/L M050.3-16	0.02	0.6	2.6	30	16	0.15	3	4.0	●			●	
R/L M050.35-10	0.02	1.1	3.1	24	10	0.17	3.5	4.0	●			●	
R/L M050.35-16	0.02	1.1	3.1	30	16	0.17	3.5	4.0	●			●	
R/L M050.35-20	0.02	1.1	3.1	34	20	0.17	3.5	4.0	●			●	
R/L M050.4-10	0.02	1.5	3.5	24	10	0.2	4	4.0	●			●	
R/L M050.4-16	0.02	1.5	3.5	30	16	0.2	4	4.0	●			●	
R/L M050.4-20	0.02	1.5	3.5	34	20	0.2	4	4.0	●			●	
R/L M050.4-24	0.02	1.5	3.5	38	24	0.2	4	4.0	●			●	

Weitere HM Sorten können Sie in der Sortenübersicht im Kapitel "Technische Hinweise" und der Preisliste finden.

Bestellbeispiel:  
für rechte Ausführung und Sorte  
RM050.25-5/P07C

### weitere Informationen:

- siehe Allgemeine Beschreibung

### more informations:

- look at the general instructions

More carbide grades you can find in the grades summary in the chapter "technical instructions" and in the price list.

order-example:  
righthand version and grade  
RM050.25-5/P07C

**BROTECH**

## ULTRAMINI

Bohrungsbearbeitung  
ab  $\varnothing 0.2$  mm

grooving, boring and profiling  
starting at  $\varnothing 0.2$  mm

## Xtraline Typ X050

Ausdrehen und Kopieren  
mit innerer Kühlmittelzufuhr,  
Spantreppe, extra stabile Ausführung

D min. 1.0 - 7.0 mm

boring and profiling  
with through coolant  
and extra solid construction

D min. 1.0 - 7.0 mm

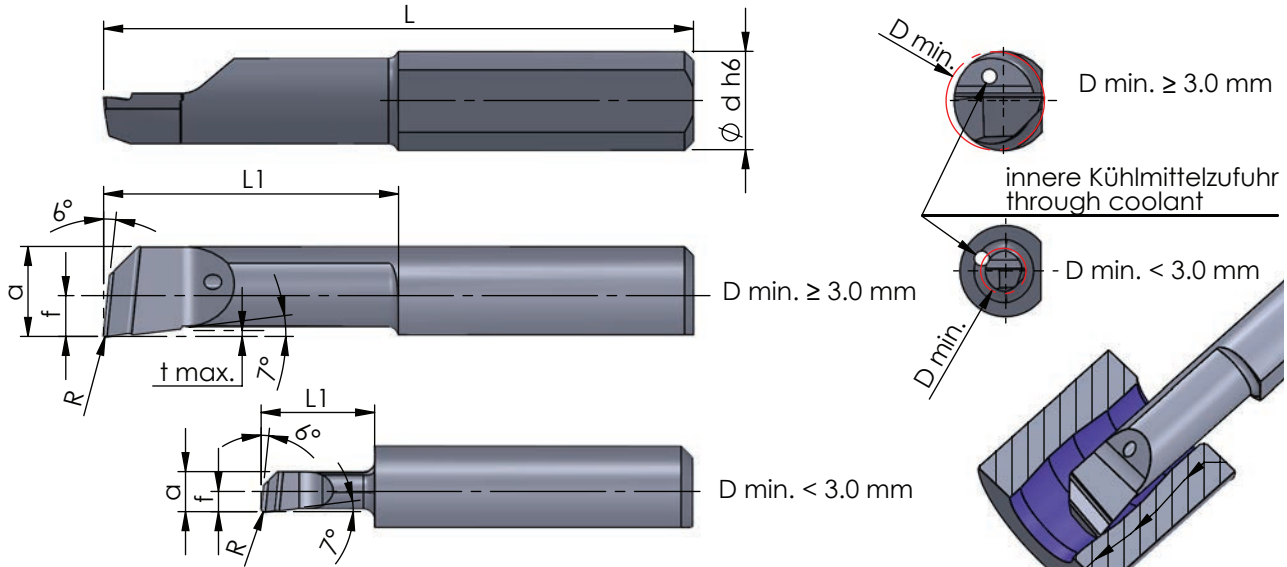

Rechts (R): wie gezeichnet  
Links (L): spiegelbildlich

righthand (R): as shown  
lefthand version (L): mirror image

Abmessungen in mm

dimensions in mm

Bestellnummer part number	R	f	a	L	L1	t max.	D min.	Ø d h6					Klemmhalter Typ toolholder type
									K10F	CN45F	AL41F	P18C	
R/L X050.1-5R05	0.05	0.45	0.9	20	5	0.03	1.0	4.0	●			●	640... 645... ...4
R/L X050.15-7R10	0.1	0.65	1.35	21	7	0.05	1.5	4.0	●			●	
R/L X050.2-5R15	0.15	0.9	1.8	19	5	0.1	2.0	4.0	●			●	
R/L X050.2-10R05	0.05	0.9	1.8	24	10	0.1	2.0	4.0	●			●	
R/L X050.2-10R15	0.15	0.9	1.8	24	10	0.1	2.0	4.0	●			●	
R/L X050.3-10R05	0.05	0.7	2.7	24	10	0.15	3.0	4.0	●			●	
R/L X050.3-10R20	0.2	0.7	2.7	24	10	0.15	3.0	4.0	●			●	
R/L X050.3-16R05	0.05	0.7	2.7	30	16	0.15	3.0	4.0	●			●	
R/L X050.3-16R10	0.1	0.7	2.7	30	16	0.15	3.0	4.0	●			●	
R/L X050.3-16R20	0.2	0.7	2.7	30	16	0.15	3.0	4.0	●			●	
↳ ...													

Weitere HM Sorten können Sie in der Sortenübersicht im Kapitel "Technische Hinweise" und der Preisliste finden.

Bestellbeispiel:  
für rechte Ausführung und Sorte  
RX050.1-5R05/P18C

### weitere Informationen:

- siehe Allgemeine Beschreibung

### more informations:

- look at the general instructions

More carbide grades you can find in the grades summary in the chapter "technical instructions" and in the price list.

order-example:  
righthand version and grade  
RX050.1-5R05/P18C

**BROTECH**

# ULTRAMINI

Bohrungsbearbeitung  
ab Ø 0.2 mm

grooving, boring and profiling  
starting at Ø 0.2 mm

# Xtraline Typ X050

Ausdrehen und Kopieren  
mit innerer Kühlmittelzufuhr,  
Spantreppe, extra stabile Ausführung

D min. 1.0 - 7.0 mm

boring and profiling  
with through coolant,  
chipbreaker and extra solid construction

D min. 1.0 - 7.0 mm

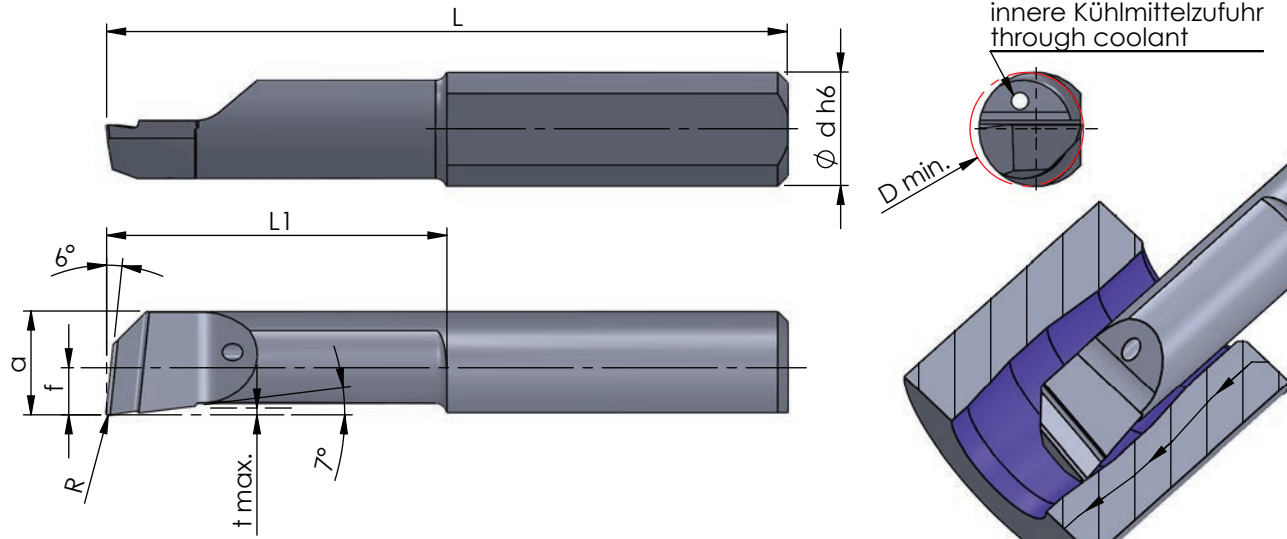

Rechts (R): wie gezeichnet  
Links (L): spiegelbildlich

righthand (R): as shown  
lefthand version (L): mirror image

Abmessungen in mm

dimensions in mm

Bestellnummer part number	R	f	a	L	L1	t max.	D min.	Ø d h6	K10F CN45F AL41F P18C	Klemmhalter Typ toolholder type
R/L X050.4-10R10	0.1	1.6	3.6	24	10	0.2	4.0	4.0	●	●
R/L X050.4-10R20	0.2	1.6	3.6	24	10	0.2	4.0	4.0	●	●
R/L X050.4-16R05	0.05	1.6	3.6	30	16	0.2	4.0	4.0	●	●
R/L X050.4-16R10	0.1	1.6	3.6	30	16	0.2	4.0	4.0	●	●
R/L X050.4-16R20	0.2	1.6	3.6	30	16	0.2	4.0	4.0	●	●
R/L X050.4-16R40	0.4	1.6	3.6	30	16	0.2	4.0	4.0	●	●
R/L X050.4-24R10	0.1	1.6	3.6	38	24	0.2	4.0	4.0	●	●
R/L X050.4-24R20	0.2	1.6	3.6	38	24	0.2	4.0	4.0	●	●
R/L X050.4-24R40	0.4	1.6	3.6	38	24	0.2	4.0	4.0	●	●

neu

neu

Weitere HM Sorten können Sie in der Sortenübersicht im Kapitel "Technische Hinweise" und der Preisliste finden.

Bestellbeispiel:  
für rechte Ausführung und Sorte  
RX050.4-10R10/P18C

### weitere Informationen:

- siehe Allgemeine Beschreibung

### more informations:

- look at the general instructions

More carbide grades you can find in the grades summary in the chapter "technical instructions" and in the price list.

order-example:  
righthand version and grade  
RX050.4-10R10/P18C



## ULTRAMINI

Bohrungsbearbeitung  
ab  $\varnothing 0.2$  mm

grooving, boring and profiling  
starting at  $\varnothing 0.2$  mm

## Xtraline Typ X050

Ausdrehen und Kopieren  
mit innerer Kühlmittelzufuhr,  
Spantreppe, extra stabile Ausführung

D min. 1.0 - 7.0 mm

boring and profiling  
with through coolant,  
chipbreaker and extra solid construction

D min. 1.0 - 7.0 mm

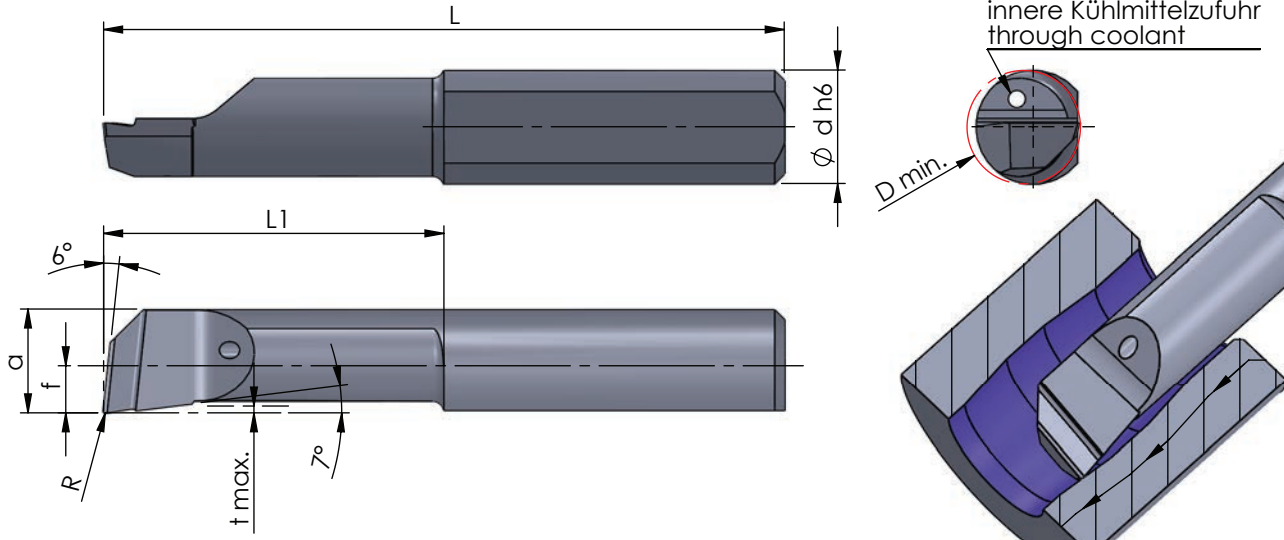

Rechts (R): wie gezeichnet  
Links (L): spiegelbildlich

righthand (R): as shown  
lefthand version (L): mirror image

Abmessungen in mm

dimensions in mm

Bestellnummer part number	R	f	a	L	L1	t max.	D min.	Ø d h6	K10F CN45F AL41F P18C	Klemmhalter Typ toolholder type
R/L X050.5-15R05	0.05	2.1	4.6	30	15	0.3	5.0	5.0	●	645, ... 650, ... ...5
R/L X050.5-15R10	0.1	2.1	4.6	30	15	0.3	5.0	5.0	●	
R/L X050.5-15R20	0.2	2.1	4.6	30	15	0.3	5.0	5.0	●	
R/L X050.5-15R40	0.4	2.1	4.6	30	15	0.3	5.0	5.0	●	
R/L X050.5-25R10	0.1	2.1	4.6	40	25	0.3	5.0	5.0	●	
R/L X050.5-25R20	0.2	2.1	4.6	40	25	0.3	5.0	5.0	●	
R/L X050.5-30R10	0.1	2.1	4.6	45	30	0.3	5.0	5.0	●	
R/L X050.5-30R20	0.2	2.1	4.6	45	30	0.3	5.0	5.0	●	
R/L X050.5-30R40	0.4	2.1	4.6	45	30	0.3	5.0	5.0	●	

Weitere HM Sorten können Sie in der Sortenübersicht im Kapitel "Technische Hinweise" und der Preisliste finden.

Bestellbeispiel:  
für rechte Ausführung und Sorte  
RX050.5-15R05/P18C

### weitere Informationen:

- siehe Allgemeine Beschreibung

### more informations:

- look at the general instructions

More carbide grades you can find in the grades summary in the chapter "technical instructions" and in the price list.

order-example:  
righthand version and grade  
RX050.5-15R05/P18C

**BROTECH**

# ULTRAMINI

Bohrungsbearbeitung  
ab  $\varnothing 0.2$  mm

grooving, boring and profiling  
starting at  $\varnothing 0.2$  mm

# Xtraline Typ X050

Ausdrehen und Kopieren  
mit innerer Kühlmittelzufuhr,  
Spantreppe, extra stabile Ausführung

boring and profiling  
with through coolant,  
chipbreaker  
and extra solid construction

D min. 1.0 - 7.0 mm

D min. 1.0 - 7.0 mm

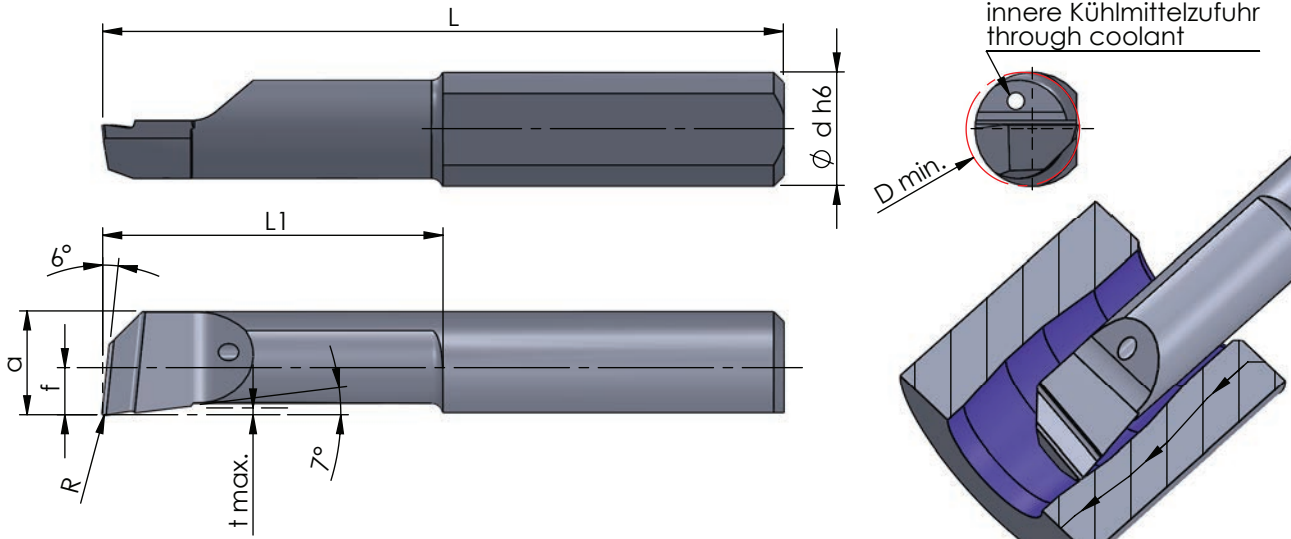

Rechts (R): wie gezeichnet  
Links (L): spiegelbildlich

righthand (R): as shown  
lefthand version (L): mirror image

Abmessungen in mm

dimensions in mm

Bestellnummer part number	R	f	a	L	L1	t max.	D min.	Ø d h6	K10F CN45F AL41F P18C	Klemmhalter Typ toolholder type
...										
R/L X050.6-15R05	0.05	2.5	5.5	30	15	0.4	6.0	6.0	●	676, ...
R/L X050.6-15R10	0.1	2.5	5.5	30	15	0.4	6.0	6.0	●	
R/L X050.6-15R20	0.2	2.5	5.5	30	15	0.4	6.0	6.0	●	
R/L X050.6-15R40	0.4	2.5	5.5	30	15	0.4	6.0	6.0	●	
R/L X050.6-22R20	0.2	2.5	5.5	37	22	0.4	6.0	6.0	●	
R/L X050.6-30R20	0.2	2.5	5.5	45	30	0.4	6.0	6.0	●	
R/L X050.6-30R40	0.4	2.5	5.5	45	30	0.4	6.0	6.0	●	
R/L X050.6-35R20	0.2	2.5	5.5	50	35	0.4	6.0	6.0	●	
R/L X050.6-42R20	0.2	2.5	5.5	57	42	0.4	6.0	6.0	●	
R/L X050.6-50R20	0.2	2.5	5.5	65	50	0.4	6.0	6.0	●	
↳ ...										

Weitere HM Sorten können Sie in der Sortenübersicht im Kapitel "Technische Hinweise" und der Preisliste finden.

Bestellbeispiel:  
für rechte Ausführung und Sorte  
RX050.6-15R05/P18C

### weitere Informationen:

- siehe Allgemeine Beschreibung

### more informations:

- look at the general instructions

More carbide grades you can find in the grades summary in the chapter "technical instructions" and in the price list.

order-example:  
righthand version and grade  
RX050.6-15R05/P18C





**ULTRAMINI**

Bohrungsbearbeitung  
ab  $\varnothing$  0.2 mm

grooving, boring and profiling  
starting at  $\varnothing$  0.2 mm

**Xtraline Typ X050**

Ausdrehen und Kopieren  
mit innerer Kühlmittelzufuhr,  
Spantreppe, extra stabile Ausführung

boring and profiling  
with through coolant,  
chipbreaker and extra solid construction

D min. 1.0 - 7.0 mm

D min. 1.0 - 7.0 mm

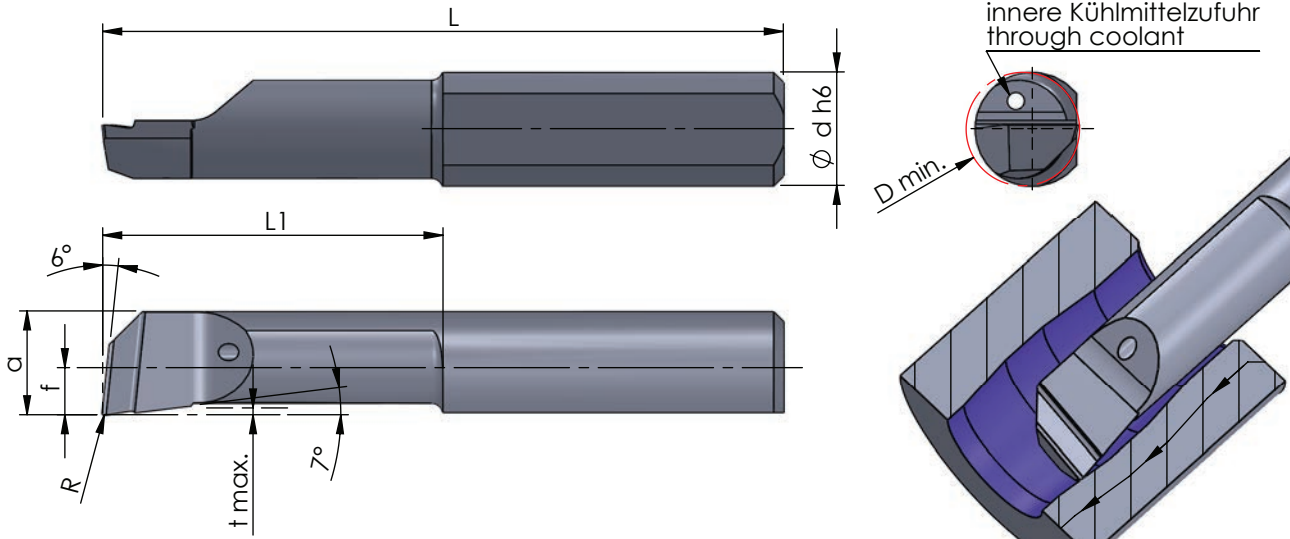

Rechts (R): wie gezeichnet  
Links (L): spiegelbildlich

righthand (R): as shown  
lefthand version (L): mirror image

Abmessungen in mm

dimensions in mm

neu  
neu  
neu  
neu  
neu

Bestellnummer part number	R	f	a	L	L1	t max.	D min.	Ø d h6	K10F CN45F AL41F P18C	Klemmhalter Typ toolholder type
R/L X050.7-25R20	0.2	3	6.5	40	25	0.5	7.0	7.0	●	●
R/L X050.7-30R20	0.2	3	6.5	45	30	0.5	7.0	7.0	●	●
R/L X050.7-30R40	0.4	3	6.5	45	30	0.5	7.0	7.0	●	●
R/L X050.7-35R20	0.2	3	6.5	50	35	0.5	7.0	7.0	●	●
R/L X050.7-40R20	0.2	3	6.5	55	40	0.5	7.0	7.0	●	●
R/L X050.7-45R20	0.2	3	6.5	60	45	0.5	7.0	7.0	●	●
R/L X050.7-50R20	0.2	3	6.5	65	50	0.5	7.0	7.0	●	●

Weitere HM Sorten können Sie in der Sortenübersicht im Kapitel "Technische Hinweise" und der Preisliste finden.

Bestellbeispiel:  
für rechte Ausführung und Sorte  
RX050.7-25R20/P18C

**weitere Informationen:**

• siehe Allgemeine Beschreibung

**more informations:**

• look at the general instructions

More carbide grades you can find in the grades summary in the chapter "technical instructions" and in the price list.

order-example:  
righthand version and grade  
RX050.7-25R20/P18C



## ULTRAMINI

Bohrungsbearbeitung  
ab  $\varnothing 0.2$  mm

grooving, boring and profiling  
starting at  $\varnothing 0.2$  mm

## Hardline Typ 050

Audreihen und Kopieren,  
für Hartbearbeitung bis 66 HRC

boring and profiling,  
for hard machining up to 66 HRC

D min. 2.0 - 6.8 mm  
Auskrägung (L1) bis 7x D

D min. 2.0 - 6.8 mm  
overhang length (L1) up to 7x D

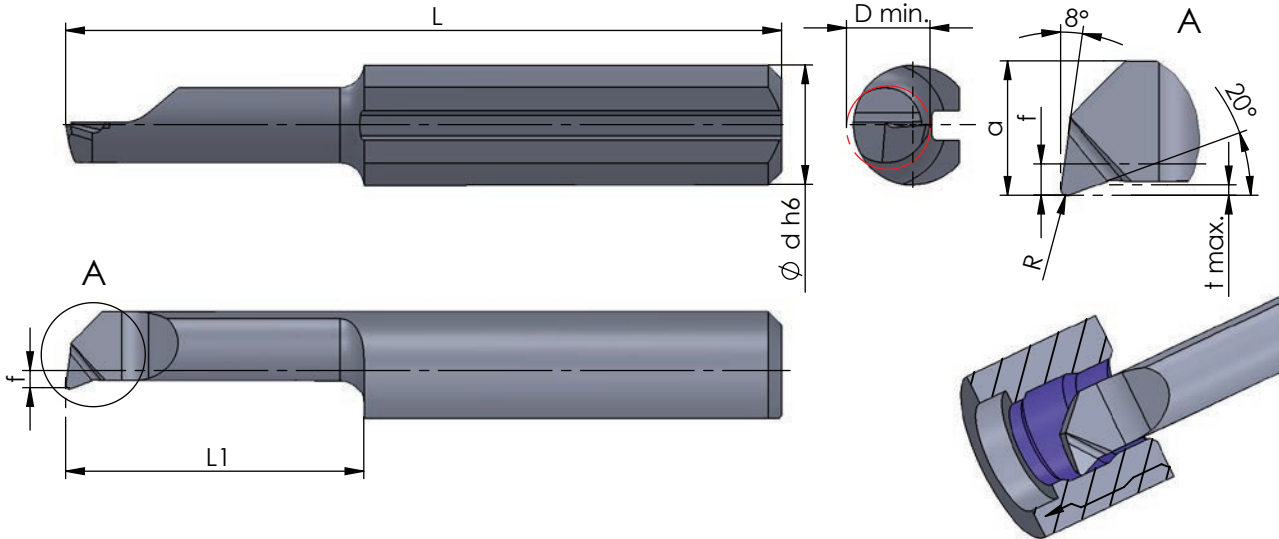

Rechts (R): wie gezeichnet  
Links (L): spiegelbildlich

righthand (R): as shown  
lefthand version (L): mirror image

Abmessungen in mm

dimensions in mm

Bestellnummer part number	R	f	a	L	L1	t max.	D min.	Ø d h6	K10F	CN45F	AL41F	XC2A-NH	Klemmhalter Typ toolholder type	
														645...
R/L 050.2-5/XC2A-NH	0.05		1.7	19	5	0.1	2.0	4.0				●	645...	640... ...4
R/L 050.2-10/XC2A-NH	0.05		1.7	24	10	0.1	2.0	4.0				●		
R/L 050.2-15/XC2A-NH	0.05		1.7	29	15	0.1	2.0	4.0				●		
R/L 050.3-10/XC2A-NH	0.1	0.6	2.6	24	10	0.2	2.8	4.0				●		
R/L 050.3-16/XC2A-NH	0.1	0.6	2.6	30	16	0.2	2.8	4.0				●		
R/L 050.3-20/XC2A-NH	0.1	0.6	2.6	34	20	0.2	2.8	4.0				●		
R/L 050.4-10/XC2A-NH	0.1	1.5	3.5	24	10	0.3	4.0	4.0				●		
R/L 050.4-16/XC2A-NH	0.1	1.5	3.5	30	16	0.3	4.0	4.0				●		
R/L 050.4-20/XC2A-NH	0.1	1.5	3.5	34	20	0.3	4.0	4.0				●		
R/L 050.4-24/XC2A-NH	0.1	1.5	3.5	38	24	0.3	4.0	4.0				●		
R/L 050.4-28/XC2A-NH	0.1	1.5	3.5	42	28	0.3	4.0	4.0				●		
R/L 050.5-10/XC2A-NH	0.15	1.9	4.4	25	10	0.5	5.0	5.0				●	650... ...5	
R/L 050.5-15/XC2A-NH	0.15	1.9	4.4	30	15	0.5	5.0	5.0				●		
R/L 050.5-20/XC2A-NH	0.15	1.9	4.4	35	20	0.5	5.0	5.0				●		
R/L 050.5-25/XC2A-NH	0.15	1.9	4.4	40	25	0.5	5.0	5.0				●		
↳ ...														

Weitere HM Sorten können Sie in der Sortenübersicht im Kapitel "Technische Hinweise" und der Preisliste finden.

Bestellbeispiel:  
für rechte Ausführung und Sorte  
R050.2-5/XC2A-NH

### weitere Informationen:

- siehe Allgemeine Beschreibung

### more informations:

- look at the general instructions

More carbide grades you can find in the grades summary in the chapter "technical instructions" and in the price list.

order-example:  
righthand version and grade  
R050.2-5/XC2A-NH

## ULTRAMINI

Bohrungsbearbeitung  
ab  $\varnothing 0.2$  mm

grooving, boring and profiling  
starting at  $\varnothing 0.2$  mm

## Hardline Typ 050

Ausdrehen und Kopieren,  
für Hartbearbeitung bis 66 HRC

boring and profiling,  
for hard machining up to 66 HRC

D min. 2.0 - 6.8 mm  
Auskrägung (L1) bis 7x D

D min. 2.0 - 6.8 mm  
overhang length (L1) up to 7x D

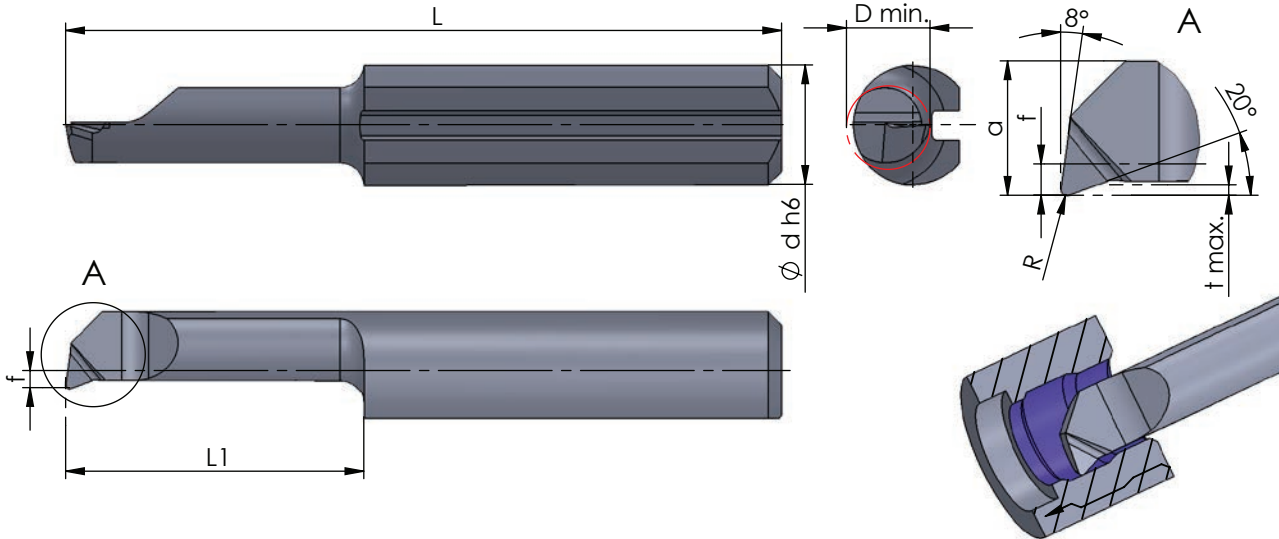

Rechts (R): wie gezeichnet  
Links (L): spiegelbildlich

righthand (R): as shown  
lefthand version (L): mirror image

Abmessungen in mm

dimensions in mm

Bestellnummer part number	R	f	a	L	L1	t max.	D min.	Ø d h6	K10F	CN45F	AL41F	XC2A-NH	Klemmhalter Typ toolholder type	
.. ↙														
R/L 050.5-30/XC2A-NH	0.15	1.9	4.4	45	30	0.5	5.0	5.0					●	645... 650... ...5
R/L 050.5-35/XC2A-NH	0.15	1.9	4.4	50	35	0.5	5.0	5.0					●	
R/L 050.6-15/XC2A-NH	0.15	2.3	5.3	30	15	0.5	6.0	6.0					●	
R/L 050.6-22/XC2A-NH	0.15	2.3	5.3	37	22	0.5	6.0	6.0					●	
R/L 050.6-25/XC2A-NH	0.15	2.3	5.3	40	25	0.5	6.0	6.0					●	660... ...6
R/L 050.6-30/XC2A-NH	0.15	2.3	5.3	45	30	0.5	6.0	6.0					●	
R/L 050.6-35/XC2A-NH	0.15	2.3	5.3	50	35	0.5	6.0	6.0					●	
R/L 050.6-42/XC2A-NH	0.15	2.3	5.3	57	42	0.5	6.0	6.0					●	
R/L 050.7-20/XC2A-NH	0.15	2.8	6.3	35	20	0.6	6.8	7.0					●	676...
R/L 050.7-25/XC2A-NH	0.15	2.8	6.3	40	25	0.6	6.8	7.0					●	
R/L 050.7-30/XC2A-NH	0.15	2.8	6.3	45	30	0.6	6.8	7.0					●	
R/L 050.7-35/XC2A-NH	0.15	2.8	6.3	50	35	0.6	6.8	7.0					●	670... 687... ...7
R/L 050.7-40/XC2A-NH	0.15	2.8	6.3	55	40	0.6	6.8	7.0					●	
R/L 050.7-45/XC2A-NH	0.15	2.8	6.3	60	45	0.6	6.8	7.0					●	
R/L 050.7-50/XC2A-NH	0.15	2.8	6.3	65	50	0.6	6.8	7.0					●	

Weitere HM Sorten können Sie in der Sortenübersicht im Kapitel "Technische Hinweise" und der Preisliste finden.

Bestellbeispiel:  
für rechte Ausführung und Sorte  
R050.5-30/XC2A-NH

### weitere Informationen:

- siehe Allgemeine Beschreibung

### more informations:

- look at the general instructions

More carbide grades you can find in the grades summary in the chapter "technical instructions" and in the price list.

order example:  
righthand version and grade  
R050.5-30/XC2A-NH

**BROTECH**

# ULTRAMINI

Bohrungsbearbeitung  
ab  $\varnothing 0.2$  mm

grooving, boring and profiling  
starting at  $\varnothing 0.2$  mm

# Typ 050..../CBN

Ausdrehen und Kopieren,  
für Hartbearbeitung

boring and profiling,  
for hard machining

D min. 2.8 - 6.8 mm

D min. 2.8 - 6.8 mm

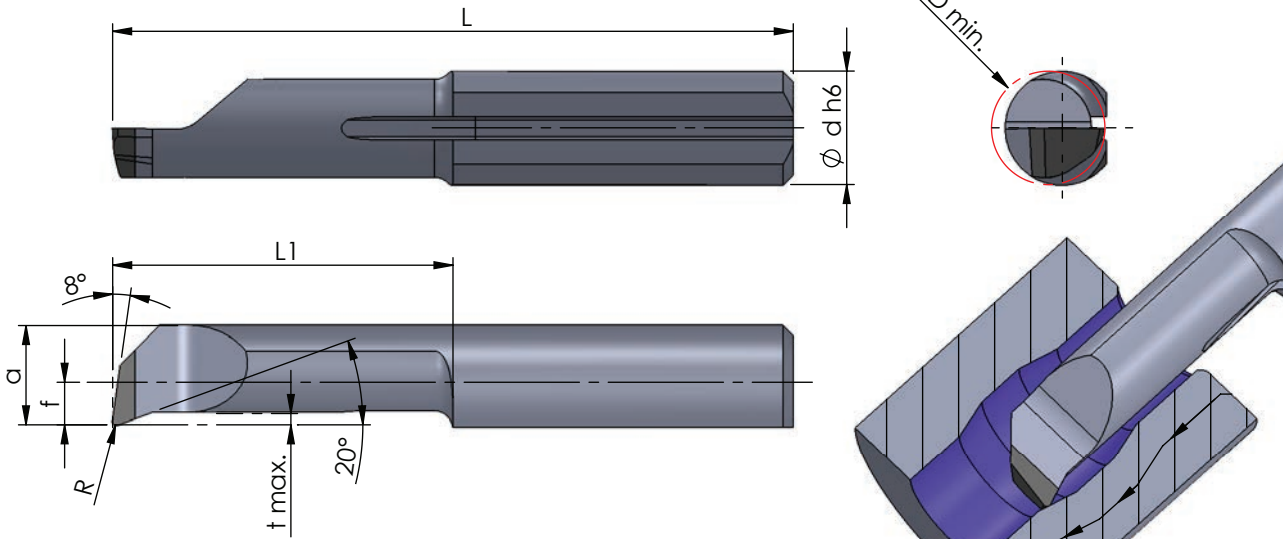

Rechts (R): wie gezeichnet  
Links (L): spiegelbildlich

righthand (R): as shown  
lefthand version (L): mirror image

Abmessungen in mm

dimensions in mm

Bestellnummer part number									K10F CN45F AL41F CBN	Klemmhalter Typ toolholder type	
	R	f	a	L	L1	t max.	D min.	$\varnothing d h6$			
R 050.3-10/CBN	0.1	0.6	2.6	25.5	10	0.2	2.8	4.0	●	645...	640... ...4
R 050.4-10/CBN	0.1	1.5	3.5	25.5	10	0.3	4.0	4.0	●		650... ...5
R 050.5-15/CBN	0.15	1.9	4.4	31.5	15	0.5	5.0	5.0	●	676...	660... ...6
R 050.6-15/CBN	0.15	2.3	5.3	31.5	15	0.5	6.0	6.0	●		687... ...7
R 050.7-20/CBN	0.15	2.8	6.3	36.5	20	0.6	6.8	7.0	●		

Weitere HM Sorten können Sie in der Sortenübersicht im Kapitel "Technische Hinweise" und der Preisliste finden.

Bestellbeispiel:  
für rechte Ausführung und Sorte  
R050.3-10/CBN

More carbide grades you can find in the grades summary in the chapter "technical instructions" and in the price list.

order example:  
righthand version and grade  
R050.3-10/CBN



**ULTRAMINI**

Bohrungsbearbeitung  
ab  $\varnothing$  0.2 mm

grooving, boring and profiling  
starting at  $\varnothing$  0.2 mm

**Typ 047**

Audreihen und Kopieren  
mit Geometrie 47° / 8°

boring and profiling  
with geometry 47° / 8°

D min. 2.0 - 6.0 mm

D min. 2.0 - 6.0 mm

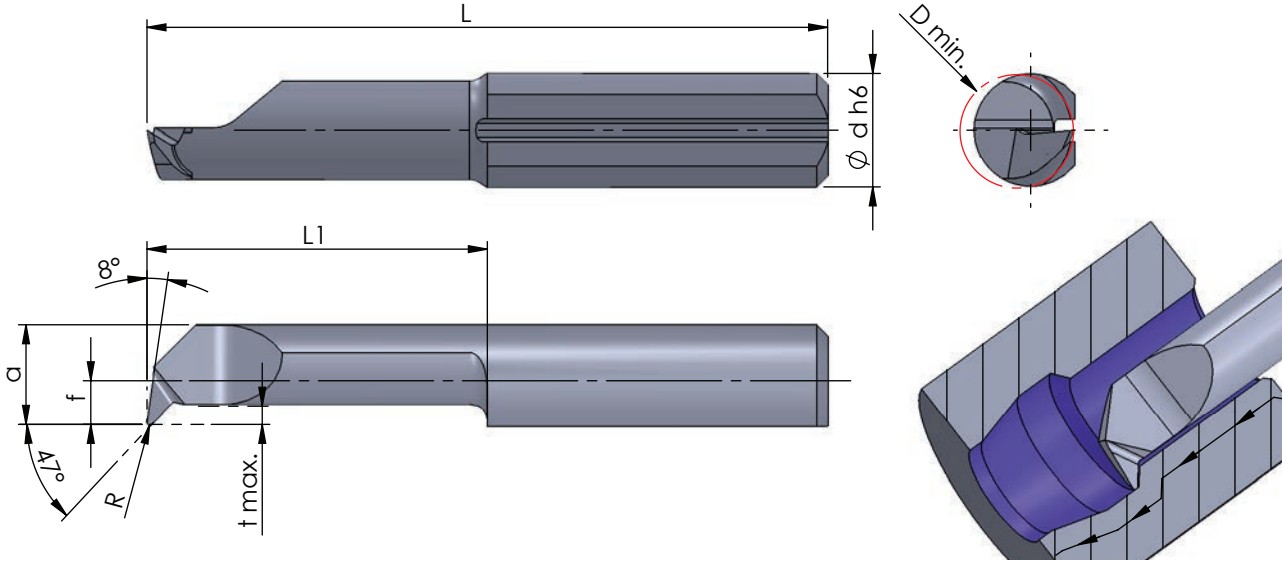

Rechts (R): wie gezeichnet  
Links (L): spiegelbildlich

righthand (R): as shown  
lefthand version (L): mirror image

Abmessungen in mm

dimensions in mm

Bestellnummer part number	R	f	a	L	L1	t max.	D min.	Ø d h6	K10F CN45F AL41F P07C	Klemmhalter Typ toolholder type	
										645... 640... ...4	650... ...5
R/L 047T2-10	0.05		1.7	24	10	0.4	2.0	4.0			
R/L 047T3-15	0.1	0.6	2.6	29	15	0.6	2.8	4.0	●	●	
R/L 047T4-10	0.1	1.5	3.5	24	10	0.6	4.0	4.0		●	
R/L 047.4-20	0.1	1.5	3.5	34	20	0.3	4.0	4.0	●	●	●
R/L 047T4-20	0.1	1.5	3.5	34	20	0.6	4.0	4.0		●	
R/L 047T5-15	0.15	1.9	4.4	30	15	0.8	5.0	5.0		●	
R/L 047.5-25	0.15	1.9	4.4	40	25	0.5	5.0	5.0	●	●	●
R/L 047T5-25	0.15	1.9	4.4	40	25	0.8	5.0	5.0		●	
R/L 047T6-22	0.15	2.3	5.3	37	22	1.8	6.0	6.0		●	
R/L 047.6-30	0.15	2.3	5.3	45	30	0.5	6.0	6.0	●	●	●
R/L 047T6-30	0.15	2.3	5.3	45	30	1.8	6.0	6.0		●	

Weitere HM Sorten können Sie in der Sortenübersicht im Kapitel "Technische Hinweise" und der Preisliste finden.

Bestellbeispiel:  
für rechte Ausführung und Sorte  
R047T2-10/AL41F

More carbide grades you can find in the grades summary in the chapter "technical instructions" and in the price list.

order-example:  
righthand version and grade  
R047T2-10/AL41F



# ULTRAMINI

Bohrungsbearbeitung  
ab  $\varnothing 0.2$  mm

grooving, boring and profiling  
starting at  $\varnothing 0.2$  mm

# Typ 090

Ausdrehen und Kopieren  
mit Geometrie  $20^\circ / 90^\circ$

boring and profiling  
with geometry  $20^\circ / 90^\circ$

D min. 2.8 - 5.0 mm

D min. 2.8 - 5.0 mm

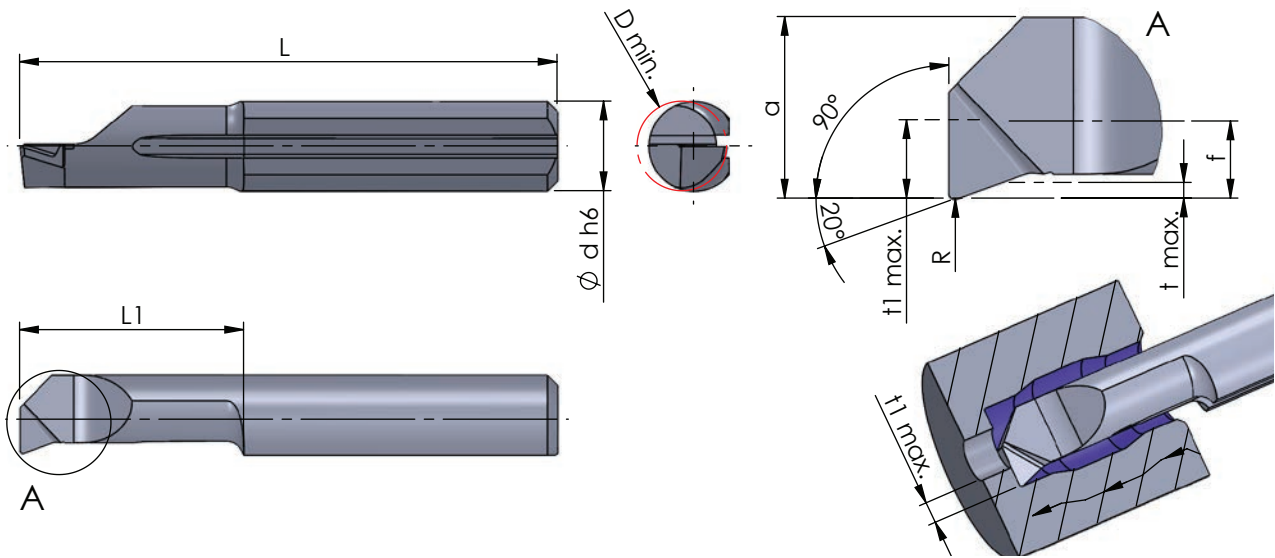

Rechts (R): wie gezeichnet  
Links (L): spiegelbildlich

righthand (R): as shown  
lefthand version (L): mirror image

Abmessungen in mm

dimensions in mm

Bestellnummer part number	R	f	a	L	L1	t max.	t1 max.	D min.	Ø d h6	Klemmhalter Typ				Klemmhalter Typ	toolholder type
										K10F	CN45F	AL41F	P07C		
R/L 090.3-10	0.1	0.6	2.6	24	10	0.2	0.8	2.8	4.0	●				645...	640... ...4
R/L 090.3-16	0.1	0.6	2.6	30	16	0.2	0.8	2.8	4.0	●					
R/L 090.4-10	0.1	1.5	3.5	24	10	0.3	1.5	4.0	4.0	●					
R/L 090.4-16	0.1	1.5	3.5	30	16	0.3	1.5	4.0	4.0	●					
R/L 090.5-10	0.15	1.9	4.4	25	10	0.5	1.8	5.0	5.0	●			645...	650... ...5	
R/L 090.5-15	0.15	1.9	4.4	30	15	0.5	1.8	5.0	5.0	●					
R/L 090.5-20	0.15	1.9	4.4	35	20	0.5	1.8	5.0	5.0	●					

Weitere HM Sorten können Sie in der Sortenübersicht im Kapitel "Technische Hinweise" und der Preisliste finden.

Bestellbeispiel:  
für rechte Ausführung und Sorte  
R090.3-10/CN45F

More carbide grades you can find in the grades summary in the chapter "technical instructions" and in the price list.

order-example:  
righthand version and grade  
R090.3-10/CN45F



## ULTRAMINI

Bohrungsbearbeitung  
ab  $\varnothing 0.2$  mm

grooving, boring and profiling  
starting at  $\varnothing 0.2$  mm

## Typ 080

Rückwärtsdrehen

D min. 3.0 - 7.0 mm

backboring

D min. 3.0 - 7.0 mm

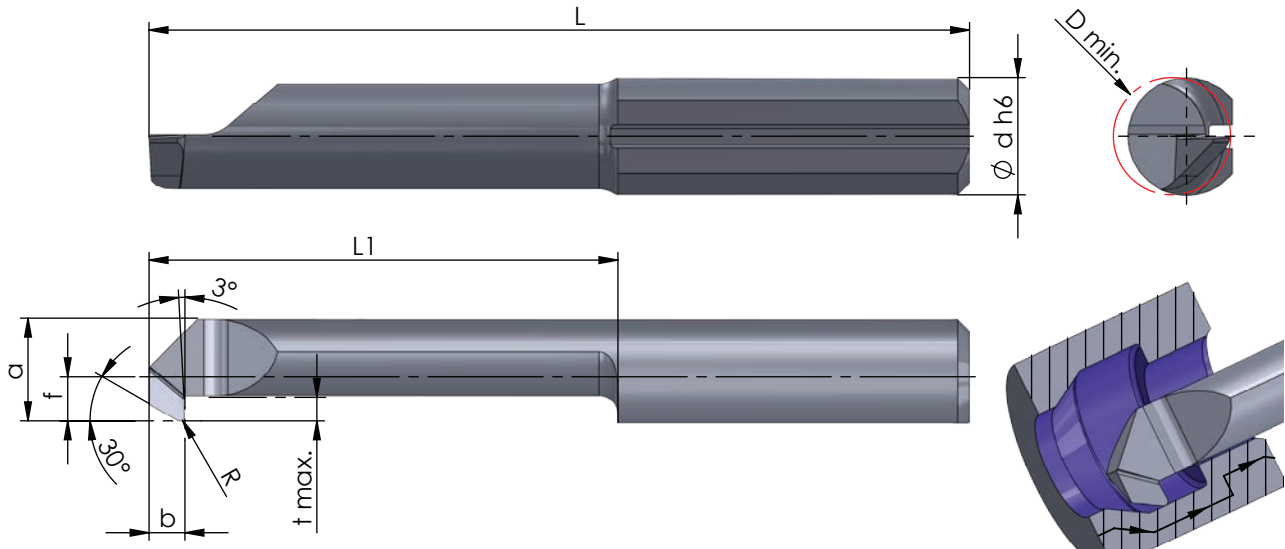

Rechts (R): wie gezeichnet  
Links (L): spiegelbildlich

righthand (R): as shown  
lefthand version (L): mirror image

Abmessungen in mm

dimensions in mm

Bestellnummer part number	b	R	f	a	L	L1	t max.	D min.	Ø d h6					Klemmhalter Typ toolholder type
										K10F	CN45F	AL41F	PD2F	
R/L 080.0003-15	1.5	0.1	0.6	2.6	29	15	0.5	3.0	4.0	●	●	●	●	645... 640... ...4 650... ...5 660... ...6 670... 687... ...7 In Kombination mit UM600H... muss mit Schlüssel gespannt werden! In combination with UM600H... you have to clamp with wrench!
R/L 080.0003-20	1.5	0.1	0.6	2.6	34	20	0.5	3.0	4.0	●	●	●	●	
R/L 080.0004-15	1.5	0.15	1.5	3.5	29	15	0.8	4.0	4.0	●	●	●	●	
R/L 080.0004-25	1.5	0.15	1.5	3.5	39	25	0.8	4.0	4.0	●	●	●	●	
R/L 080.0005-20	1.5	0.2	1.9	4.4	35	20	1.0	5.0	5.0	●	●	●	●	
R/L 080.0005-30	1.5	0.2	1.9	4.4	45	30	1.0	5.0	5.0	●	●	●	●	
R/L 080.0006-20	1.5	0.2	2.3	5.3	35	20	1.8	6.0	6.0	●	●	●	●	
R/L 080.0006-30	1.5	0.2	2.3	5.3	45	30	1.8	6.0	6.0	●	●	●	●	
R/L 080.0007-20	1.5	0.2	2.8	6.3	35	20	2.5	7.0	7.0	●	●	●	●	
R/L 080.0007-30	1.5	0.2	2.8	6.3	45	30	2.5	7.0	7.0	●	●	●	●	

Weitere HM Sorten können Sie in der Sortenübersicht im Kapitel "Technische Hinweise" und der Preisliste finden.

Bestellbeispiel:  
für rechte Ausführung und Sorte  
R080.0003-15/CN45F

More carbide grades you can find in the grades summary in the chapter "technical instructions" and in the price list.

order-example:  
righthand version and grade  
R080.0003-15/CN45F

**BROTECH**

## ULTRAMINI

Bohrungsbearbeitung  
ab  $\varnothing$  0.2 mm

grooving, boring and profiling  
starting at  $\varnothing$  0.2 mm

## Impressionen

impressions

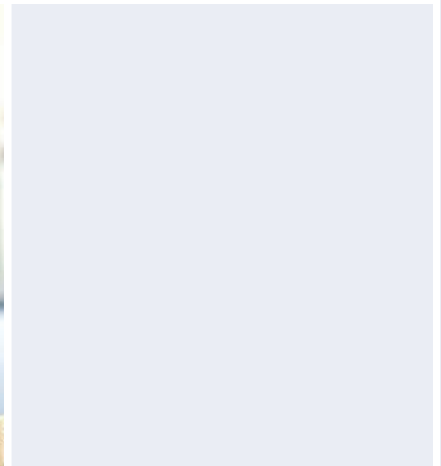
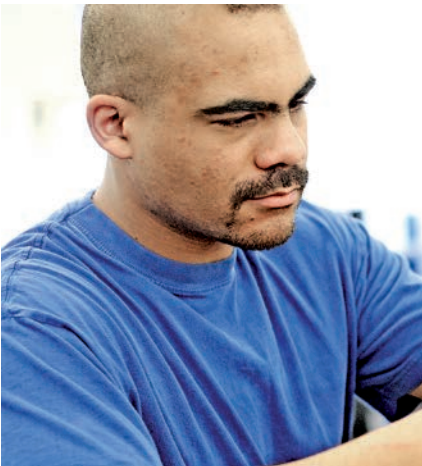
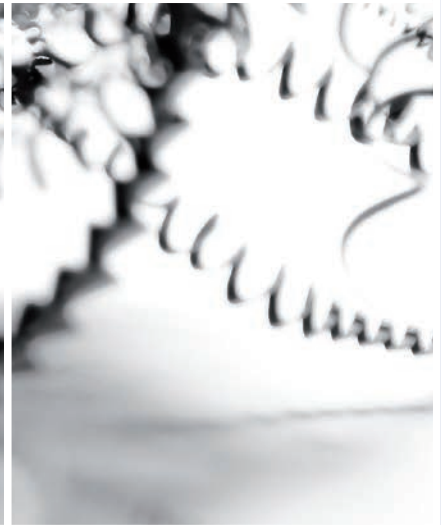
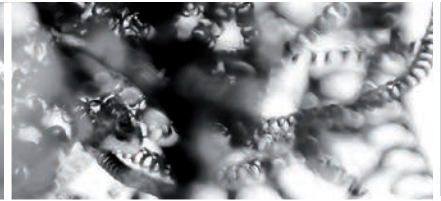



**ULTRAMINI**

Bohrungsbearbeitung  
ab  $\varnothing 0.2$  mm

grooving, boring and profiling  
starting at  $\varnothing 0.2$  mm

**Typ 001 / 0015**

Stechdrehen

D min. 1.0 / 1.5 mm  
Stechtiefe t max. 0.2 / 0.4 mm

grooving

D min. 1.0 / 1.5 mm  
depth of groove t max. 0.2 / 0.4 mm

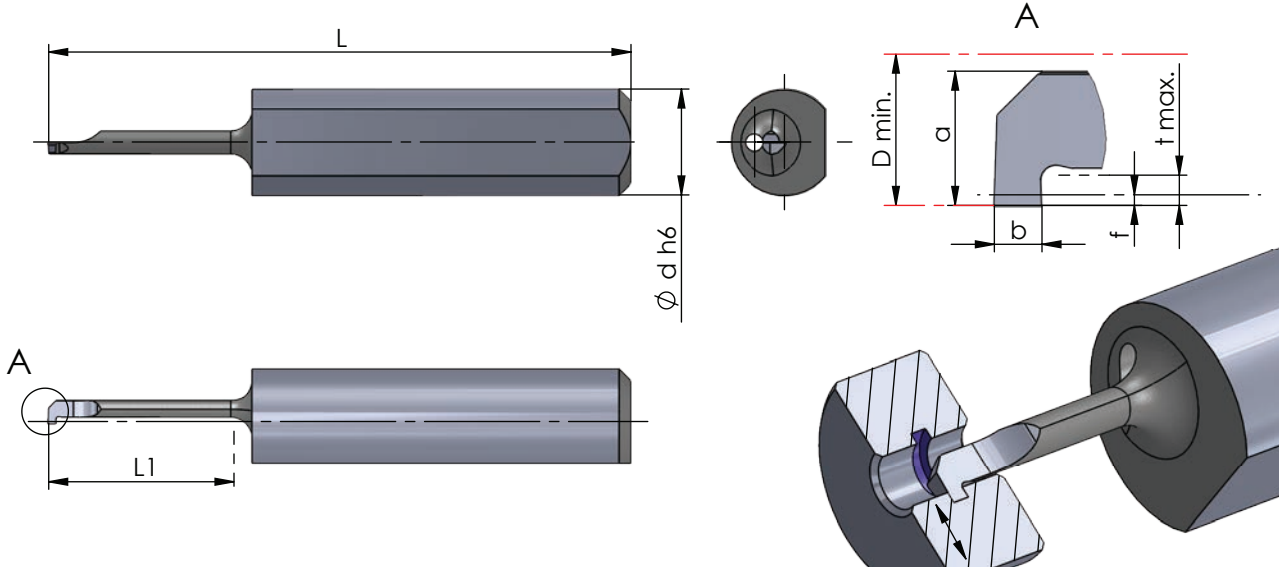

Rechts (R): wie gezeichnet  
Links (L): spiegelbildlich

righthand (R): as shown  
lefthand version (L): mirror image

Abmessungen in mm

dimensions in mm

	Bestellnummer part number	b +0.03	a	f	L	L1	t max.	D min.	Ø d h6	Klemmhalter Typ toolholder type				
										K10F	CN45F	AL41F	P07C	
neu	R/L 001.0030-4	0.3	0.9	0.1	20	4	0.2	1.0	4.0			●		
neu	R/L 001.0030-7	0.3	0.9	0.1	22	7	0.2	1.0	4.0			●		
neu	R/L 0015.0040-5	0.4	1.4	0.55	22	5	0.4	1.5	4.0			●		640... 645... ...4
neu	R/L 0015.0040-10	0.4	1.4	0.55	25	10	0.4	1.5	4.0			●		
neu	R/L 0015.0040-12	0.4	1.4	0.55	27	12	0.4	1.5	4.0			●		

Weitere HM Sorten können Sie in der Sortenübersicht im Kapitel "Technische Hinweise" und der Preisliste finden.

Bestellbeispiel:  
für rechte Ausführung und Sorte  
R001.0030-4/AL41F

More carbide grades you can find in the grades summary in the chapter "technical instructions" and in the price list.

order-example:  
righthand version and grade  
R001.0030-4/AL41F



# ULTRAMINI

Bohrungsbearbeitung  
ab  $\varnothing 0.2 \text{ mm}$

grooving, boring and profiling  
starting at  $\varnothing 0.2 \text{ mm}$

# Typ 002

Stechdrehen

grooving

D min. 2.0 mm  
Stechtiefe t max. 0.4 mm

D min. 2.0 mm  
depth of groove t max. 0.4 mm

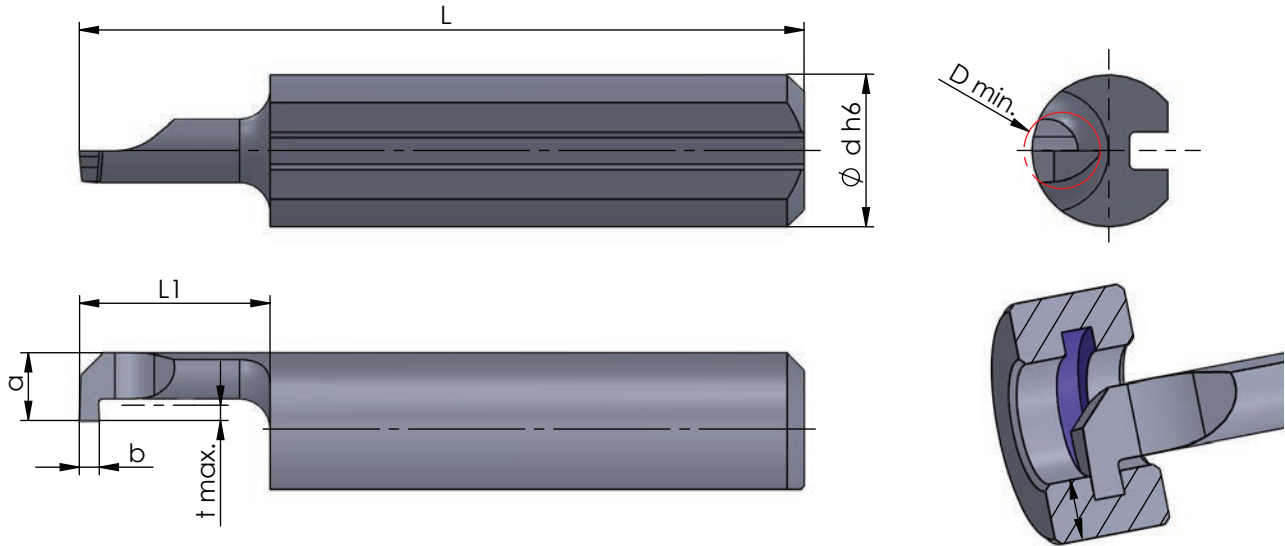

Rechts (R): wie gezeichnet  
Links (L): spiegelbildlich

righthand (R): as shown  
lefthand version (L): mirror image

Abmessungen in mm

dimensions in mm

Bestellnummer part number	b +0.05	a	L	L1	t max.	D min.	Ø d h6	K10F CN45F AL41F P07C	Klemmhalter Typ	toolholder type
									640... 645... ...4	
R/L 002.0050-5	0.5	1.8	19	5	0.4	2.0	4.0	●		
R/L 002.0050-10	0.5	1.8	24	10	0.4	2.0	4.0	●		
R/L 002.0050-15	0.5	1.8	29	15	0.4	2.0	4.0	●		

Weitere HM Sorten können Sie in der Sortenübersicht im Kapitel "Technische Hinweise" und der Preisliste finden.

Bestellbeispiel:  
für rechte Ausführung und Sorte  
R002.0050-5/AL41F

More carbide grades you can find in the grades summary in the chapter "technical instructions" and in the price list.

order-example:  
righthand version and grade  
R002.0050-5/AL41F

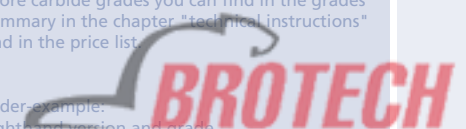

**ULTRAMINI**

Bohrungsbearbeitung  
ab  $\varnothing$  0.2 mm

grooving, boring and profiling  
starting at  $\varnothing$  0.2 mm

**Typ 003**

Stechdrehen

grooving

D min. 3.0 mm  
Stechtiefe t max. 0.6 mm

D min. 3.0 mm  
depth of groove t max. 0.6 mm

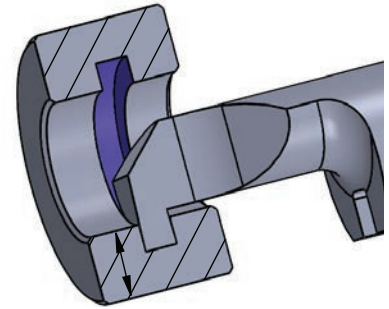
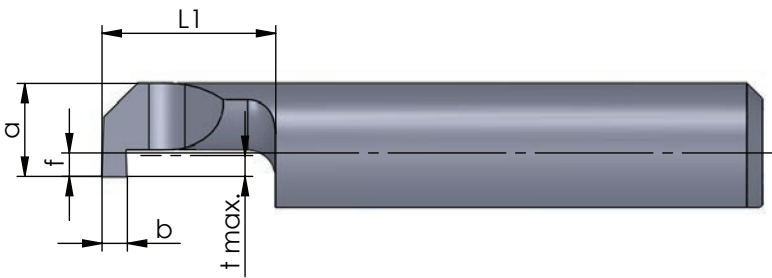
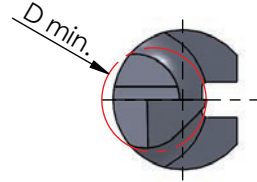

Rechts (R): wie gezeichnet  
Links (L): spiegelbildlich

righthand (R): as shown  
lefthand version (L): mirror image

Abmessungen in mm

dimensions in mm

Bestellnummer part number	b +0.05	f	a	L	L1	t max.	D min.	$\varnothing$ d h6	K10F CN45F AL41F P07C	Klemmhalter Typ	toolholder type
R/L 003.0070-5	0.7	0.7	2.7	19	5	0.6	3.0	4.0			
R/L 003.0070-10	0.7	0.7	2.7	24	10	0.6	3.0	4.0			640... 645... ...4
R/L 003.0070-16	0.7	0.7	2.7	30	16	0.6	3.0	4.0			

Weitere HM Sorten können Sie in der Sortenübersicht im Kapitel "Technische Hinweise" und der Preisliste finden.

Bestellbeispiel:  
für rechte Ausführung und Sorte  
R003.0070-5/AL41F

More carbide grades you can find in the grades summary in the chapter "technical instructions" and in the price list.

order-example:  
righthand version and grade  
R003.0070-5/AL41F



# ULTRAMINI

Bohrungsbearbeitung  
ab  $\varnothing 0.2 \text{ mm}$

grooving, boring and profiling  
starting at  $\varnothing 0.2 \text{ mm}$

# Typ 004

Stechdrehen

D min. 4.0 mm  
Stechtiefe t max. 0.8 mm

grooving

D min. 4.0 mm  
depth of groove t max. 0.8 mm

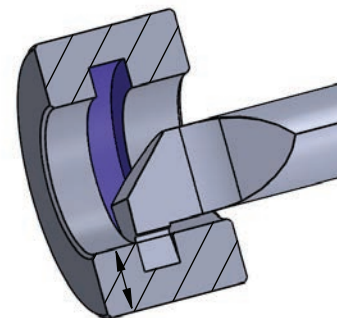
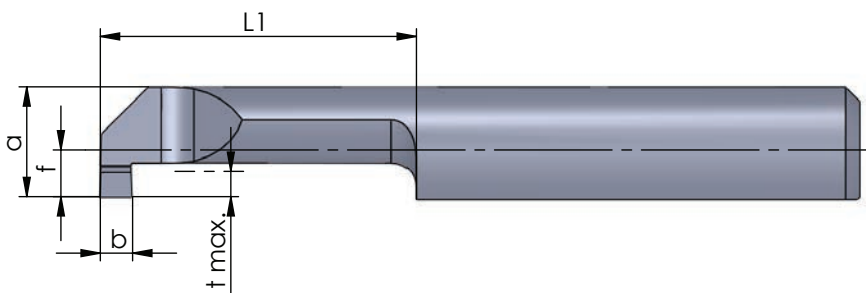
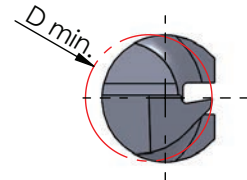
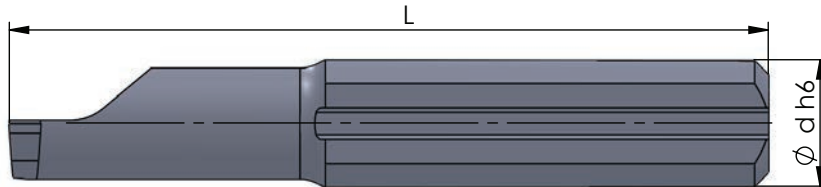

Rechts (R): wie gezeichnet  
Links (L): spiegelbildlich

righthand (R): as shown  
lefthand version (L): mirror image

Abmessungen in mm

dimensions in mm

Bestellnummer part number	b +0.05	f	a	L	L1	t max.	D min.	Ø d h6					Klemmhalter Typ toolholder type
									K10F	CN45F	AL41F	P07C	
R/L 004.0100-10	1.0	1.5	3.5	24	10	0.8	4.0	4.0	●	●	●		
R/L 004.0100-16	1.0	1.5	3.5	30	16	0.8	4.0	4.0	●	●	●		640... 645... ...4
R/L 004.0100-20	1.0	1.5	3.5	34	20	0.8	4.0	4.0	●	●	●		

Weitere HM Sorten können Sie in der Sortenübersicht im Kapitel "Technische Hinweise" und der Preisliste finden.

Bestellbeispiel:  
für rechte Ausführung und Sorte  
R004.0100-10/AL41F

More carbide grades you can find in the grades summary in the chapter "technical instructions" and in the price list.

order-example:  
righthand version and grade  
R004.0100-10/AL41F



**ULTRAMINI**

Bohrungsbearbeitung  
ab  $\varnothing 0.2 \text{ mm}$

grooving, boring and profiling  
starting at  $\varnothing 0.2 \text{ mm}$

**Typ 004M**

Stechdrehen  
mit Eckenradius

grooving  
with corner radius

D min. 4.0 mm  
Stechtiefe t max. 0.8 mm

D min. 4.0 mm  
depth of groove t max. 0.8 mm

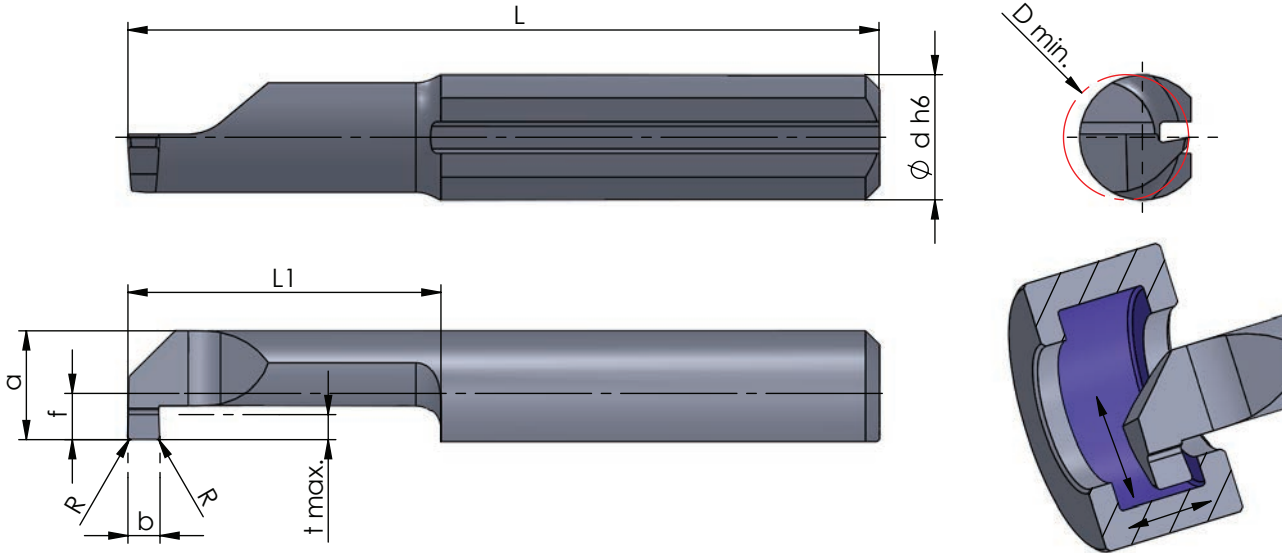

Rechts (R): wie gezeichnet  
Links (L): spiegelbildlich

righthand (R): as shown  
lefthand version (L): mirror image

Abmessungen in mm

dimensions in mm

Bestellnummer part number	b +0.05	b (inch)	R	f	a	L	L1	t max.	D min.	$\varnothing d h6$	Klemmhalter Typ toolholder type				
											K10F	CN45F	AL41F	P07C	
R/L 004M0079-20	0.79	0.031"	0.1	1.5	3.5	34	20	0.8	4.0	4.0	●				
R/L 004M0100-10	1.0		0.1	1.5	3.5	24	10	0.8	4.0	4.0	●				
R/L 004M0100-16	1.0		0.1	1.5	3.5	30	16	0.8	4.0	4.0	●				640... 645... ...4
R/L 004M0100-20	1.0		0.1	1.5	3.5	34	20	0.8	4.0	4.0	●				

Weitere HM Sorten können Sie in der Sortenübersicht im Kapitel "Technische Hinweise" und der Preisliste finden.

Bestellbeispiel:  
für rechte Ausführung und Sorte  
R004M0079-20/AL41F

More carbide grades you can find in the grades summary in the chapter "technical instructions" and in the price list.

order-example:  
righthand version and grade  
R004M0079-20/AL41F



# ULTRAMINI

Bohrungsbearbeitung  
ab  $\varnothing$  0.2 mm

grooving, boring and profiling  
starting at  $\varnothing$  0.2 mm

# Typ 005

Stechdrehen

grooving

D min. 5.0 mm  
Stechtiefe t max. 1.0 mm  
Auskragung (L1) bis 7x D

D min. 5.0 mm  
depth of groove t max. 1.0 mm  
overhang length (L1) up to 7x D

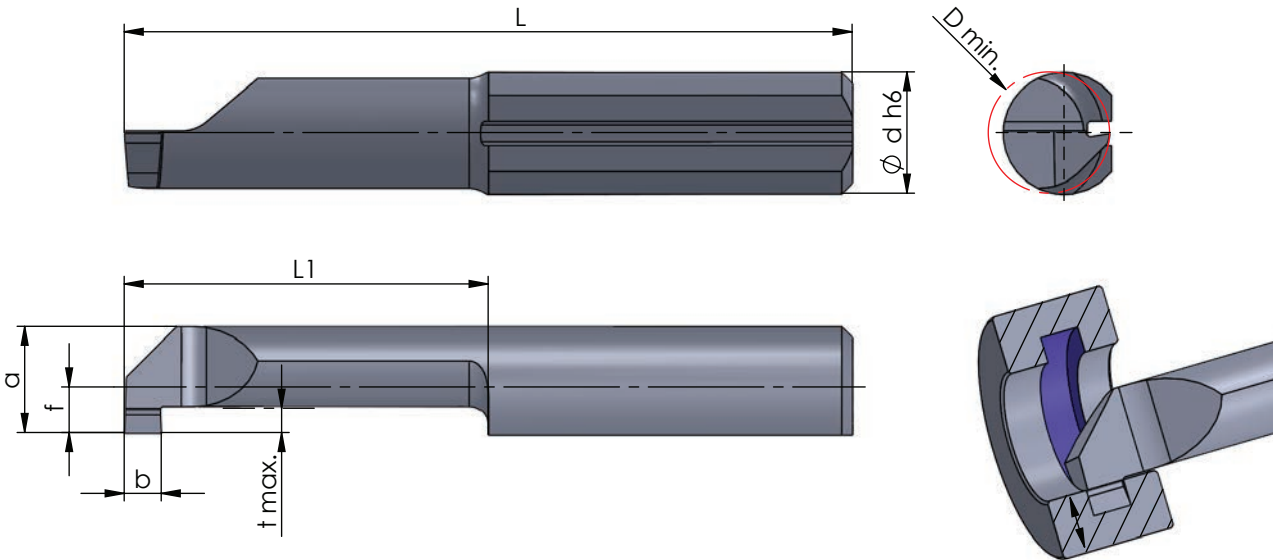

Rechts (R): wie gezeichnet  
Links (L): spiegelbildlich

righthand (R): as shown  
lefthand version (L): mirror image

Abmessungen in mm

dimensions in mm

neu

Bestellnummer part number	b +0.05		f	a	L	L1	t max.	D min.	Ø d h6	K10F	CN45F	AL41F	P07C	Klemmhalter Typ toolholder type
	b	b (inch)												
R/L 005.0100-10	1.0		1.9	4.4	25	10	1.0	5.0	5.0	●	●			645... 650... ...5
R/L 005.0100-15	1.0		1.9	4.4	30	15	1.0	5.0	5.0	●	●			
R/L 005.0100-20	1.0		1.9	4.4	35	20	1.0	5.0	5.0	●	●			
R/L 005.0100-25	1.0		1.9	4.4	40	25	1.0	5.0	5.0	●	●			
R/L 005.0100-30	1.0		1.9	4.4	45	30	1.0	5.0	5.0	●	●			
R/L 005.0100-35	1.0		1.9	4.4	50	35	1.0	5.0	5.0		●			
R/L 005.0117-30	1.17	0.046"	1.9	4.4	45	30	1.0	5.0	5.0			●		
R/L 005.0150-10	1.5		1.9	4.4	25	10	1.0	5.0	5.0	●	●			
R/L 005.0150-15	1.5		1.9	4.4	30	15	1.0	5.0	5.0	●	●			
R/L 005.0150-20	1.5		1.9	4.4	35	20	1.0	5.0	5.0	●	●			
R/L 005.0150-25	1.5		1.9	4.4	40	25	1.0	5.0	5.0	●	●			
R/L 005.0150-30	1.5		1.9	4.4	45	30	1.0	5.0	5.0	●	●			
↳ ...														

Weitere HM Sorten können Sie in der Sortenübersicht im Kapitel "Technische Hinweise" und der Preisliste finden.

Bestellbeispiel:  
für rechte Ausführung und Sorte  
R005.0100-10/CN45F

More carbide grades you can find in the grades summary in the chapter "technical instructions" and in the price list.

order-example:  
righthand version and grade  
R005.0100-10/CN45F

## ULTRAMINI

Bohrungsbearbeitung  
ab  $\varnothing 0.2 \text{ mm}$

grooving, boring and profiling  
starting at  $\varnothing 0.2 \text{ mm}$

## Typ 005

Stechdrehen

grooving

D min. 5.0 mm  
Stechtiefe t max. 1.0 mm  
Auskragung (L1) bis 7x D

D min. 5.0 mm  
depth of groove t max. 1.0 mm  
overhang length (L1) up to 7x D

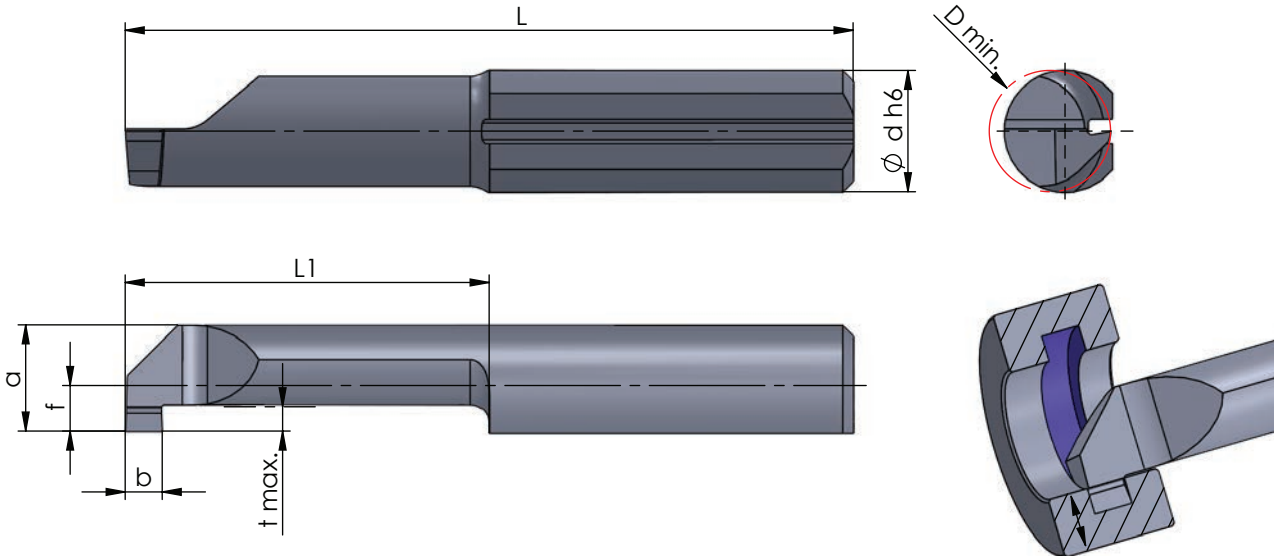

Rechts (R): wie gezeichnet  
Links (L): spiegelbildlich

righthand (R): as shown  
lefthand version (L): mirror image

Abmessungen in mm

dimensions in mm

Bestellnummer part number	b +0.05	b (inch)	f	a	L	L1	t max.	D min.	$\varnothing d h6$	Klemmhalter Typ toolholder type			
										K10F	CN45F	AL41F	P07C
R/L 005.0200-10	2.0	1.9	4.4	25	10	1.0	5.0	5.0	●	●			
R/L 005.0200-15	2.0	1.9	4.4	30	15	1.0	5.0	5.0	●	●			
R/L 005.0200-20	2.0	1.9	4.4	35	20	1.0	5.0	5.0	●	●			
R/L 005.0200-25	2.0	1.9	4.4	40	25	1.0	5.0	5.0	●	●			
R/L 005.0200-30	2.0	1.9	4.4	45	30	1.0	5.0	5.0	●	●			

Weitere HM Sorten können Sie in der Sortenübersicht im Kapitel "Technische Hinweise" und der Preisliste finden.

Bestellbeispiel:  
für rechte Ausführung und Sorte  
R005.0200-10/CN45F

More carbide grades you can find in the grades summary in the chapter "technical instructions" and in the price list.

order-example:  
righthand version and grade  
R005.0200-10/CN45F

**BROTECH**

# ULTRAMINI

Bohrungsbearbeitung  
ab  $\varnothing$  0.2 mm

grooving, boring and profiling  
starting at  $\varnothing$  0.2 mm

# Typ 005M

Stechdrehen  
mit Eckenradius

grooving  
with corner radius

D min. 5.0 mm  
Stechtiefe t max. 1.0 mm

D min. 5.0 mm  
depth of groove t max. 1.0 mm

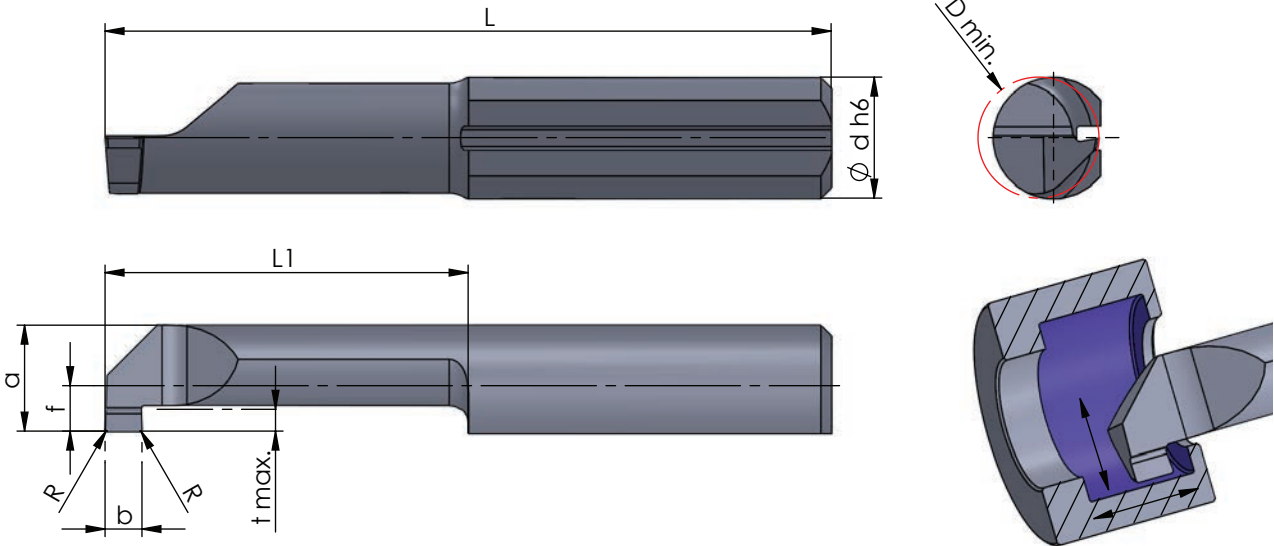

Rechts (R): wie gezeichnet  
Links (L): spiegelbildlich

righthand (R): as shown  
lefthand version (L): mirror image

Abmessungen in mm

dimensions in mm

Bestellnummer part number	b +0.05	b (inch)	R	f	a	L	L1	t max.	D min.	$\varnothing$ d h6	Klemmhalter Typ toolholder type					
											K10F	CN45F	AL41F	P07C		
R/L 005M0100-10	1.0		0.1	1.9	4.4	25	10	1.0	5.0	5.0		●				
R/L 005M0100-15	1.0		0.1	1.9	4.4	30	15	1.0	5.0	5.0		●				
R/L 005M0100-20	1.0		0.1	1.9	4.4	35	20	1.0	5.0	5.0		●				
R/L 005M0100-25	1.0		0.1	1.9	4.4	40	25	1.0	5.0	5.0		●				
R/L 005M0100-30	1.0		0.1	1.9	4.4	45	30	1.0	5.0	5.0		●				
R/L 005M0150-10	1.5		0.1	1.9	4.4	25	10	1.0	5.0	5.0		●			645... 650... ...5	
R/L 005M0150-15	1.5		0.1	1.9	4.4	30	15	1.0	5.0	5.0		●				
R/L 005M0150-20	1.5		0.1	1.9	4.4	35	20	1.0	5.0	5.0		●				
R/L 005M0150-25	1.5		0.1	1.9	4.4	40	25	1.0	5.0	5.0		●				
R/L 005M0150-30	1.5		0.1	1.9	4.4	45	30	1.0	5.0	5.0		●				
R/L 005M0157-20	1.57	0.062"	0.1	1.9	4.4	35	20	1.0	5.0	5.0		●				
↳ ...																

Weitere HM Sorten können Sie in der Sortenübersicht im Kapitel "Technische Hinweise" und der Preisliste finden.

Bestellbeispiel:  
für rechte Ausführung und Sorte  
R005M0100-10/AL41F

More carbide grades you can find in the grades summary in the chapter "technical instructions" and in the price list.

order-example:  
righthand version and grade  
R005M0100-10/AL41F





## ULTRAMINI

Bohrungsbearbeitung  
ab  $\varnothing$  0.2 mm

grooving, boring and profiling  
starting at  $\varnothing$  0.2 mm

## Typ 005M

Stechdrehen  
mit Eckenradius

grooving  
with corner radius

D min. 5.0 mm  
Stechtiefe t max. 1.0 mm

D min. 5.0 mm  
depth of groove t max. 1.0 mm

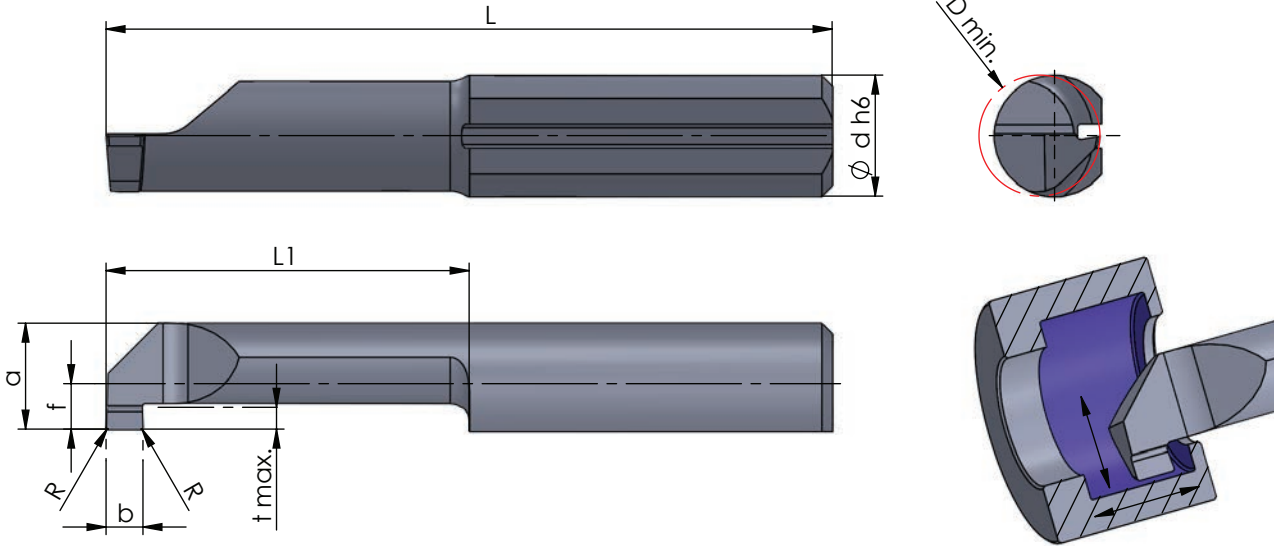

Rechts (R): wie gezeichnet  
Links (L): spiegelbildlich

righthand (R): as shown  
lefthand version (L): mirror image

Abmessungen in mm

dimensions in mm

Bestellnummer part number	b +0.05	b (inch)	R	f	a	L	L1	t max.	D min.	$\varnothing$ d h6	Klemmhalter Typ				Klemmhalter Typ toolholder type
											K10F	CN45F	AL41F	P07C	
...															
R/L 005M0200-10	2.0		0.1	1.9	4.4	25	10	1.0	5.0	5.0		●			
R/L 005M0200-15	2.0		0.1	1.9	4.4	30	15	1.0	5.0	5.0		●			
R/L 005M0200-20	2.0		0.1	1.9	4.4	35	20	1.0	5.0	5.0		●			645... 650... ...5
R/L 005M0200-25	2.0		0.1	1.9	4.4	40	25	1.0	5.0	5.0		●			
R/L 005M0200-30	2.0		0.1	1.9	4.4	45	30	1.0	5.0	5.0		●			

Weitere HM Sorten können Sie in der Sortenübersicht im Kapitel "Technische Hinweise" und der Preisliste finden.

Bestellbeispiel:  
für rechte Ausführung und Sorte  
R005M0200-10/AL41F

More carbide grades you can find in the grades summary in the chapter "technical instructions" and in the price list.

order-example:  
righthand version and grade  
R005M0200-10/AL41F

**BROTECH**

# ULTRAMINI

Bohrungsbearbeitung  
ab  $\varnothing$  0.2 mm

grooving, boring and profiling  
starting at  $\varnothing$  0.2 mm

# Typ 006

Stechdrehen

grooving

D min. 6.0 mm  
Stechtiefe t max. 1.8 mm  
Auskragung (L1) bis 7x D

D min. 6.0 mm  
depth of groove t max. 1.8 mm  
overhang length (L1) up to 7x D

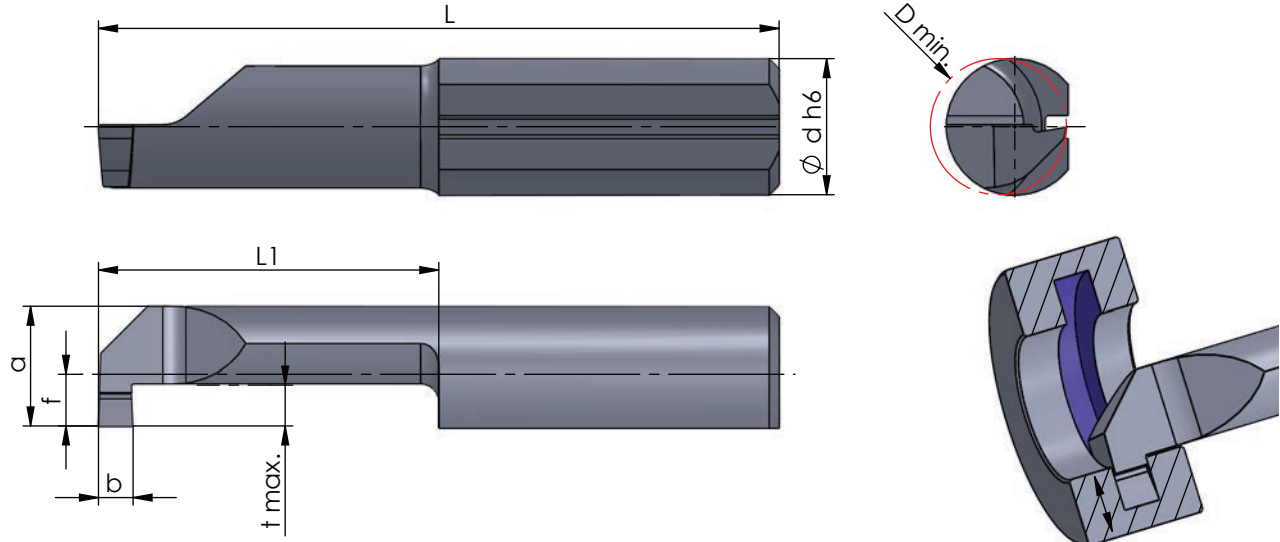

Rechts (R): wie gezeichnet  
Links (L): spiegelbildlich

righthand (R): as shown  
lefthand version (L): mirror image

Abmessungen in mm

dimensions in mm

Bestellnummer part number	b +0.05	f	a	L	L1	t max.	D min.	$\varnothing$ d h6	K10F CN45F AL41F P07C	Klemmhalter Typ	toolholder type
										660... 676... ...6	
R/L 006.0100-10	1.0	2.3	5.3	25	10	1.8	6.0	6.0	● ●		
R/L 006.0100-15	1.0	2.3	5.3	30	15	1.8	6.0	6.0	● ●		
R/L 006.0100-22	1.0	2.3	5.3	37	22	1.8	6.0	6.0	● ●		
R/L 006.0100-25	1.0	2.3	5.3	40	25	1.8	6.0	6.0	● ●		
R/L 006.0100-30	1.0	2.3	5.3	45	30	1.8	6.0	6.0	● ●		
R/L 006.0100-35	1.0	2.3	5.3	50	35	1.8	6.0	6.0	● ●		
R/L 006.0100-42	1.0	2.3	5.3	57	42	1.8	6.0	6.0	●		
R/L 006.0150-10	1.5	2.3	5.3	25	10	1.8	6.0	6.0	● ●		
R/L 006.0150-15	1.5	2.3	5.3	30	15	1.8	6.0	6.0	● ●		
R/L 006.0150-22	1.5	2.3	5.3	37	22	1.8	6.0	6.0	● ●		
R/L 006.0150-25	1.5	2.3	5.3	40	25	1.8	6.0	6.0	● ●		
R/L 006.0150-30	1.5	2.3	5.3	45	30	1.8	6.0	6.0	● ●		
R/L 006.0150-35	1.5	2.3	5.3	50	35	1.8	6.0	6.0	● ●		
↳ ...											

Weitere HM Sorten können Sie in der Sortenübersicht im Kapitel "Technische Hinweise" und der Preisliste finden.

Bestellbeispiel:  
für rechte Ausführung und Sorte  
R006.0100-10/CN45F

More carbide grades you can find in the grades summary in the chapter "technical instructions" and in the price list.

order-example:  
righthand version and grade  
R006.0100-10/CN45F



**ULTRAMINI**

Bohrungsbearbeitung  
ab  $\varnothing 0.2 \text{ mm}$

grooving, boring and profiling  
starting at  $\varnothing 0.2 \text{ mm}$

**Typ 006**

Stechdrehen

grooving

D min. 6.0 mm  
Stechtiefe t max. 1.8 mm  
Auskrägung (L1) bis 7x D

D min. 6.0 mm  
depth of groove t max. 1.8 mm  
overhang length (L1) up to 7x D

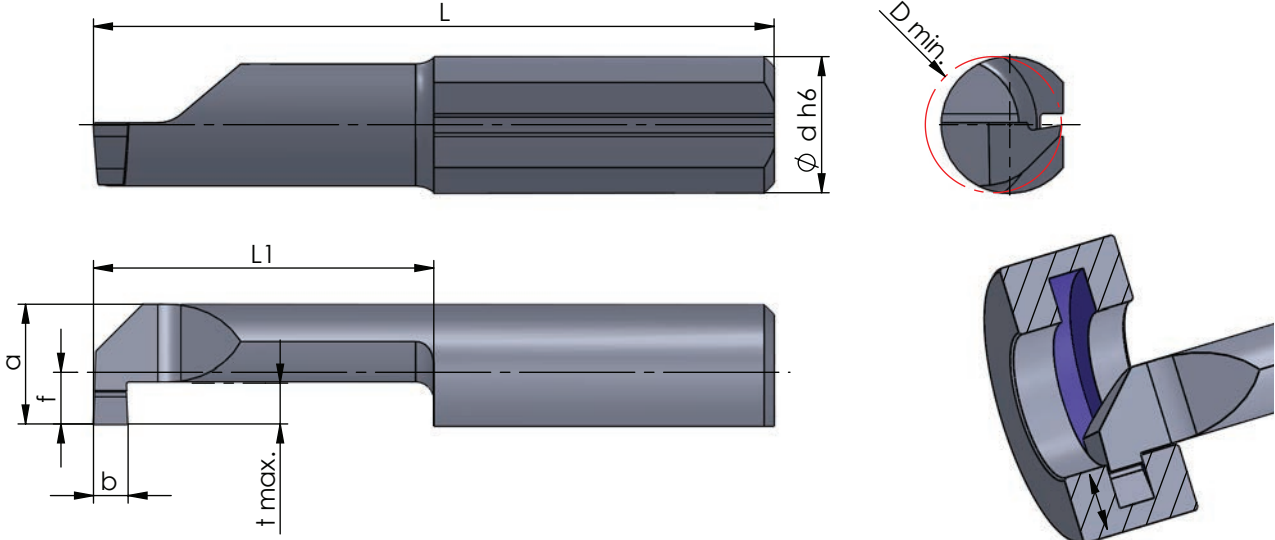

Rechts (R): wie gezeichnet  
Links (L): spiegelbildlich

righthand (R): as shown  
lefthand version (L): mirror image

Abmessungen in mm

dimensions in mm

Bestellnummer part number	b +0.05	f	a	L	L1	t max.	D min.	$\varnothing d h6$	Klemmhalter Typ				Klemmhalter Typ toolholder type
									K10F	CN45F	AL41F	P07C	
...													
R/L 006.0200-10	2.0	2.3	5.3	25	10	1.8	6.0	6.0	●	●			
R/L 006.0200-15	2.0	2.3	5.3	30	15	1.8	6.0	6.0	●	●	●		
R/L 006.0200-22	2.0	2.3	5.3	37	22	1.8	6.0	6.0	●	●			
R/L 006.0200-25	2.0	2.3	5.3	40	25	1.8	6.0	6.0	●	●			
R/L 006.0200-30	2.0	2.3	5.3	45	30	1.8	6.0	6.0	●	●			

Weitere HM Sorten können Sie in der Sortenübersicht im Kapitel "Technische Hinweise" und der Preisliste finden.

Bestellbeispiel:  
für rechte Ausführung und Sorte  
R006.0200-10/CN45F

More carbide grades you can find in the grades summary in the chapter "technical instructions" and in the price list.

order-example:  
righthand version and grade  
R006.0200-10/CN45F



# ULTRAMINI

Bohrungsbearbeitung  
ab  $\varnothing$  0.2 mm

grooving, boring and profiling  
starting at  $\varnothing$  0.2 mm

# Typ 006M

Stechdrehen  
mit Eckenradius

grooving  
with corner radius

D min. 6.0 mm  
Stechtiefe t max. 1.8 mm

D min. 6.0 mm  
depth of groove t max. 1.8 mm

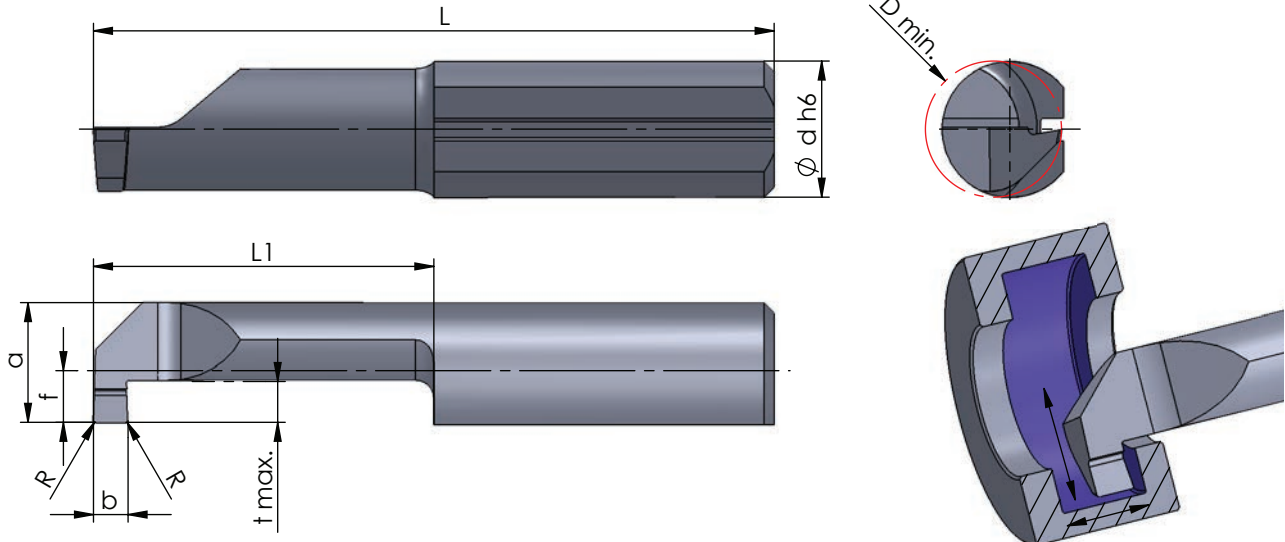

Rechts (R): wie gezeichnet  
Links (L): spiegelbildlich

righthand (R): as shown  
lefthand version (L): mirror image

Abmessungen in mm

dimensions in mm

Bestellnummer part number	b +0.05	b (inch)	R	f	a	L	L1	t max.	D min.	Ø d h6	Klemmhalter Typ				Klemmhalter Typ toolholder type
											K10F	CN45F	AL41F	PD2F	
R/L 006M0079-15	0.79	0.031"	0.1	2.3	5.3	30	15	1.8	6.0	6.0		●			660... 676... ...6
R/L 006M0100-10	1.0		0.1	2.3	5.3	25	10	1.8	6.0	6.0		●	●		
R/L 006M0100-15	1.0		0.1	2.3	5.3	30	15	1.8	6.0	6.0		●			
R/L 006M0100-22	1.0		0.1	2.3	5.3	37	22	1.8	6.0	6.0		●			
R/L 006M0100-25	1.0		0.1	2.3	5.3	40	25	1.8	6.0	6.0		●			
R/L 006M0100-30	1.0		0.1	2.3	5.3	45	30	1.8	6.0	6.0		●			
R/L 006M0117-15	1.17	0.046"	0.1	2.3	5.3	30	15	1.8	6.0	6.0		●			
R/L 006M0150-10	1.5		0.1	2.3	5.3	25	10	1.8	6.0	6.0		●			
R/L 006M0150-15	1.5		0.1	2.3	5.3	30	15	1.8	6.0	6.0		●			
R/L 006M0150-22	1.5		0.1	2.3	5.3	37	22	1.8	6.0	6.0		●			
R/L 006M0150-25	1.5		0.1	2.3	5.3	40	25	1.8	6.0	6.0		●			
R/L 006M0150-30	1.5		0.1	2.3	5.3	45	30	1.8	6.0	6.0		●			
↳ ...															

Weitere HM Sorten können Sie in der Sortenübersicht im Kapitel "Technische Hinweise" und der Preisliste finden.

Bestellbeispiel:  
für rechte Ausführung und Sorte  
R006M0100-10/AL41F

More carbide grades you can find in the grades summary in the chapter "technical instructions" and in the price list.

order-example:  
righthand version and grade  
R006M0100-10/AL41F



## ULTRAMINI

Bohrungsbearbeitung  
ab  $\varnothing 0.2$  mm

grooving, boring and profiling  
starting at  $\varnothing 0.2$  mm

## Typ 006M

Stechdrehen  
mit Eckenradius

grooving  
with corner radius

D min. 6.0 mm  
Stechtiefe t max. 1.8 mm

D min. 6.0 mm  
depth of groove t max. 1.8 mm

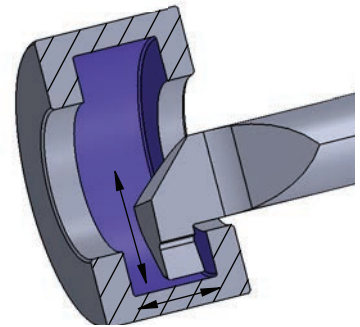
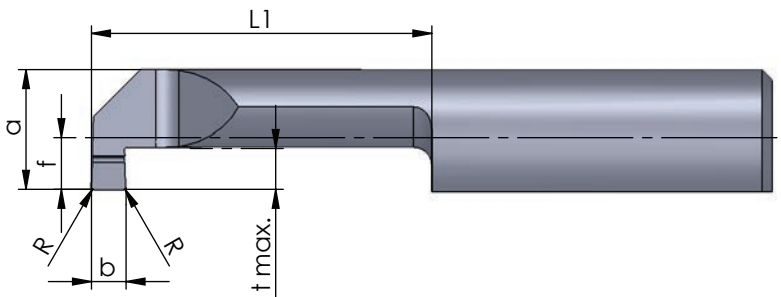
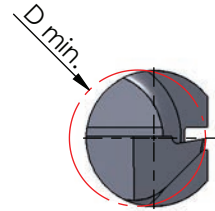
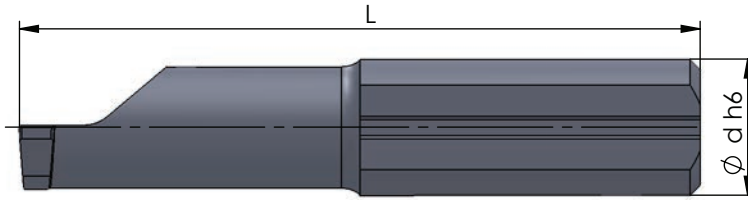

Rechts (R): wie gezeichnet  
Links (L): spiegelbildlich

righthand (R): as shown  
lefthand version (L): mirror image

Abmessungen in mm

dimensions in mm

Bestellnummer part number	b +0.05	b (inch)	R	f	a	L	L1	t max.	D min.	Ø d h6	Klemmhalter Typ				Klemmhalter Typ toolholder type
											K10F	CN45F	AL41F	PD2F	
↕															
R/L 006M0198-15	1.98	0.078"	0.1	2.3	5.3	30	15	1.8	6.0	6.0		●			
R/L 006M0200-10	2.0		0.1	2.3	5.3	25	10	1.8	6.0	6.0		●			
R/L 006M0200-15	2.0		0.1	2.3	5.3	30	15	1.8	6.0	6.0		●			
R/L 006M0200-22	2.0		0.1	2.3	5.3	37	22	1.8	6.0	6.0		●			660... 676... ...:6
R/L 006M0200-25	2.0		0.1	2.3	5.3	40	25	1.8	6.0	6.0		●			
R/L 006M0200-30	2.0		0.1	2.3	5.3	45	30	1.8	6.0	6.0		●			

Weitere HM Sorten können Sie in der Sortenübersicht im Kapitel "Technische Hinweise" und der Preisliste finden.

Bestellbeispiel:  
für rechte Ausführung und Sorte  
R006M0198-15/AL41F

More carbide grades you can find in the grades summary in the chapter "technical instructions" and in the price list.

order-example:  
righthand version and grade  
R006M0198-15/AL41F

**BROTECH**

# ULTRAMINI

Bohrungsbearbeitung  
ab  $\varnothing 0.2 \text{ mm}$

grooving, boring and profiling  
starting at  $\varnothing 0.2 \text{ mm}$

# Typ 007

Stechdrehen

grooving

D min. 6.8 mm  
Stechtiefe t max. 2.5 mm  
Auskragung (L1) bis 7x D

D min. 6.8 mm  
depth of groove t max. 2.5 mm  
overhang length (L1) up to 7x D

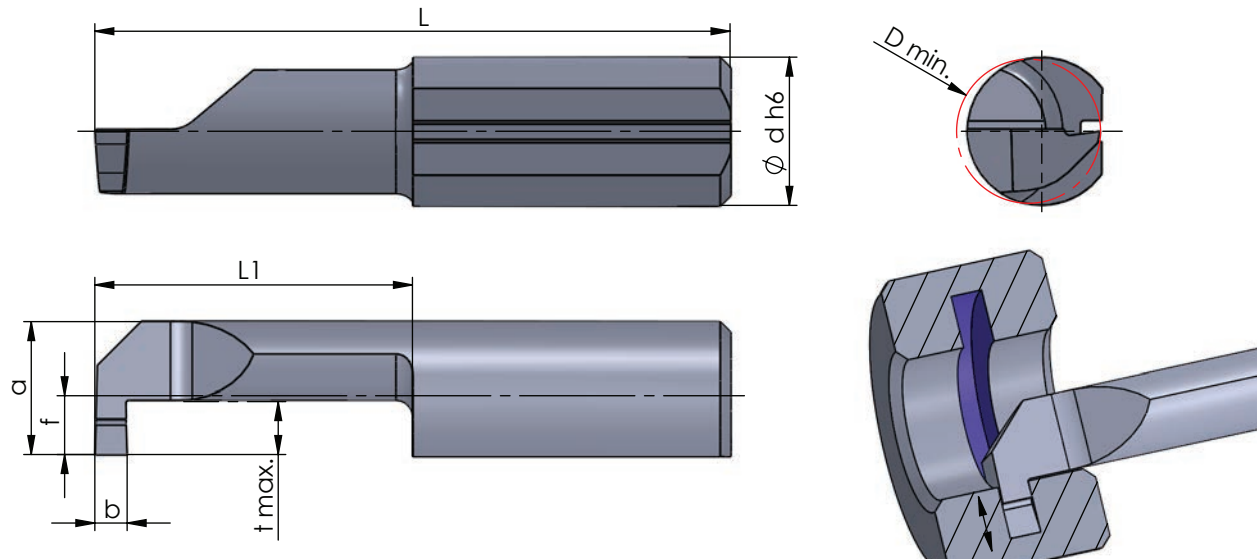

Rechts (R): wie gezeichnet  
Links (L): spiegelbildlich

righthand (R): as shown  
lefthand version (L): mirror image

Abmessungen in mm

dimensions in mm

Bestellnummer part number	b +0.05	b (inch)	f	a	L	L1	t max.	D min.	$\varnothing d h6$	Klemmhalter Typ toolholder type				
										K10F	CN45F	AL41F	PD2F	
R/L 007.0079-10	0.79	0.031"	2.8	6.3	25	10	2.5	6.8	7.0	●		●		670... 676... 687... ...7
R/L 007.0079-25	0.79	0.031"	2.8	6.3	40	25	2.5	6.8	7.0	●		●		
R/L 007.0100-10	1.0		2.8	6.3	25	10	2.5	6.8	7.0	●	●			
R/L 007.0100-15	1.0		2.8	6.3	30	15	2.5	6.8	7.0	●	●			
R/L 007.0100-22	1.0		2.8	6.3	37	22	2.5	6.8	7.0	●	●			
R/L 007.0100-25	1.0		2.8	6.3	40	25	2.5	6.8	7.0	●	●			
R/L 007.0100-30	1.0		2.8	6.3	45	30	2.5	6.8	7.0	●	●			
R/L 007.0100-35	1.0		2.8	6.3	50	35	2.5	7.0	7.0		●			
R/L 007.0100-40	1.0		2.8	6.3	55	40	2.5	7.0	7.0		●			
R/L 007.0100-45	1.0		2.8	6.3	60	45	2.5	7.0	7.0		●			
R/L 007.0100-50	1.0		2.8	6.3	65	50	2.5	7.0	7.0		●			

Weitere HM Sorten können Sie in der Sortenübersicht im Kapitel "Technische Hinweise" und der Preisliste finden.

Bestellbeispiel:  
für rechte Ausführung und Sorte  
R007.0100-10/CN45F

More carbide grades you can find in the grades summary in the chapter "technical instructions" and in the price list.

order-example:  
righthand version and grade  
R007.0100-10/CN45F



**ULTRAMINI**

Bohrungsbearbeitung  
ab  $\varnothing$  0.2 mm

grooving, boring and profiling  
starting at  $\varnothing$  0.2 mm

**Typ 007**

Stechdrehen

D min. 6.8 mm  
Stechtiefe t max. 2.5 mm

grooving

D min. 6.8 mm  
depth of groove t max. 2.5 mm

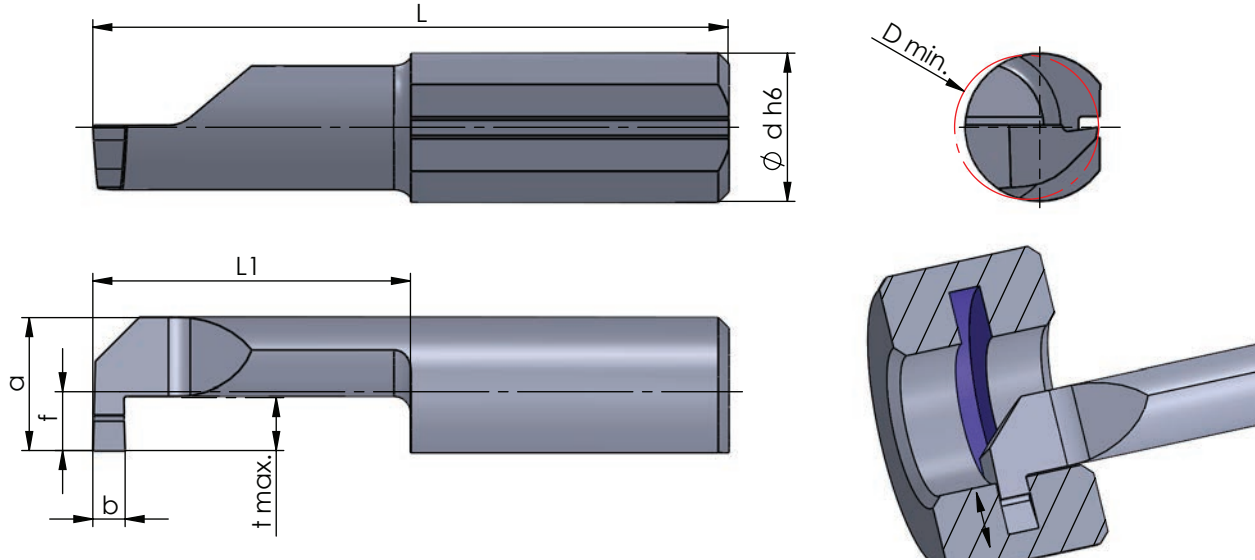

Rechts (R): wie gezeichnet  
Links (L): spiegelbildlich

righthand (R): as shown  
lefthand version (L): mirror image

Abmessungen in mm

dimensions in mm

Bestellnummer part number	b +0.05	b (inch)	f	a	L	L1	t max.	D min.	$\varnothing$ d h6	Klemmhalter Typ				Klemmhalter Typ toolholder type	
										K10F	CN45F	AL41F	PD2F		
...															
R/L 007.0150-10	1.5		2.8	6.3	25	10	2.5	6.8	7.0	●	●			670... 676... 687... ...7	
R/L 007.0150-15	1.5		2.8	6.3	30	15	2.5	6.8	7.0	●	●				
R/L 007.0150-22	1.5		2.8	6.3	37	22	2.5	6.8	7.0	●	●				
R/L 007.0150-25	1.5		2.8	6.3	40	25	2.5	6.8	7.0	●	●				
R/L 007.0150-30	1.5		2.8	6.3	45	30	2.5	6.8	7.0	●	●				
R/L 007.0150-35	1.5		2.8	6.3	50	35	2.5	7.0	7.0		●	●			
R/L 007.0150-40	1.5		2.8	6.3	55	40	2.5	7.0	7.0		●	●			
R/L 007.0200-10	2.0		2.8	6.3	25	10	2.5	6.8	7.0	●	●				
R/L 007.0200-15	2.0		2.8	6.3	30	15	2.5	6.8	7.0	●	●				
R/L 007.0200-22	2.0		2.8	6.3	37	22	2.5	6.8	7.0	●	●				
R/L 007.0200-25	2.0		2.8	6.3	40	25	2.5	6.8	7.0	●	●				
R/L 007.0200-30	2.0		2.8	6.3	45	30	2.5	6.8	7.0	●	●	●			
R/L 007.0200-35	2.0		2.8	6.3	50	35	2.5	7.0	7.0	●	●	●			

Weitere HM Sorten können Sie in der Sortenübersicht im Kapitel "Technische Hinweise" und der Preisliste finden.

Bestellbeispiel:  
für rechte Ausführung und Sorte  
R007.0150-10/CN45F

More carbide grades you can find in the grades summary in the chapter "technical instructions" and in the price list.

order-example:  
righthand version and grade  
R007.0150-10/CN45F



# ULTRAMINI

Bohrungsbearbeitung  
ab  $\varnothing$  0.2 mm

grooving, boring and profiling  
starting at  $\varnothing$  0.2 mm

# Typ 007M

Stechdrehen  
mit Eckenradius

grooving  
with corner radius

D min. 6.8 mm  
Stechtiefe t max. 2.5 mm

D min. 6.8 mm  
depth of groove t max. 2.5 mm

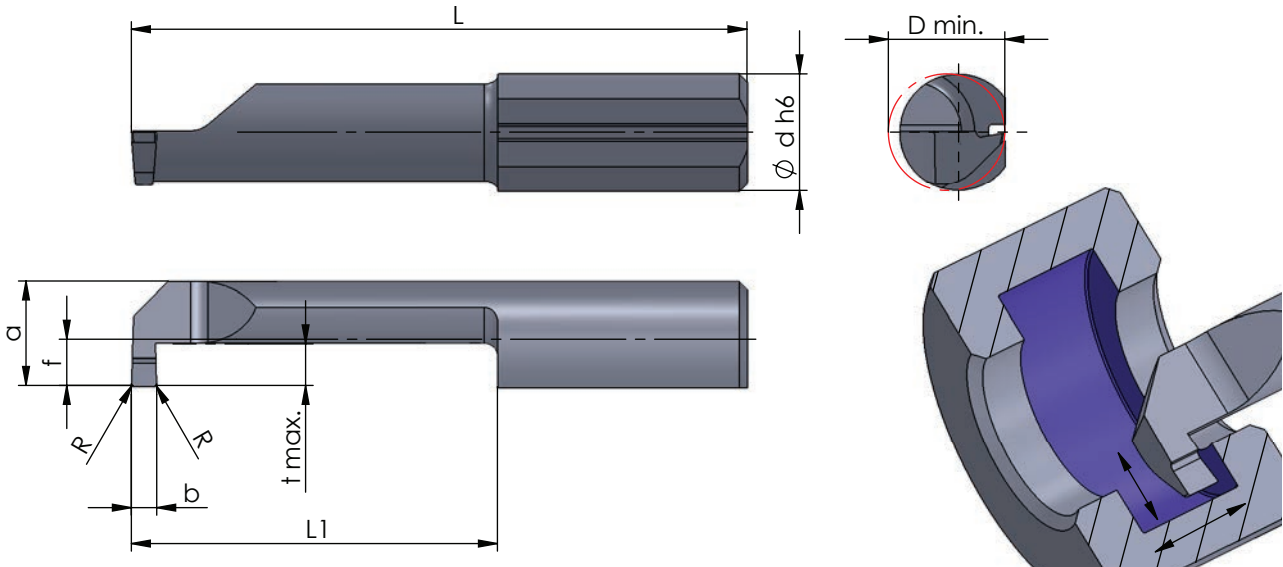

Rechts (R): wie gezeichnet  
Links (L): spiegelbildlich

righthand (R): as shown  
lefthand version (L): mirror image

Abmessungen in mm

dimensions in mm

Bestellnummer part number	b +0.05	b (inch)	R	f	a	L	L1	t max.	D min.	Ø d h6	Klemmhalter Typ				Klemmhalter Typ toolholder type	
											K10F	CN45F	AL41F	P07C		
R/L 007M0100-10	1.0		0.1	2.8	6.3	25	10	2.5	6.8	7.0			●		670... 676... 687... ...7	
R/L 007M0100-15	1.0		0.1	2.8	6.3	30	15	2.5	6.8	7.0			●			
R/L 007M0100-22	1.0		0.1	2.8	6.3	37	22	2.5	6.8	7.0			●			
R/L 007M0100-25	1.0		0.1	2.8	6.3	40	25	2.5	6.8	7.0			●			
R/L 007M0100-30	1.0		0.1	2.8	6.3	45	30	2.5	6.8	7.0			●			
R/L 007M0117-10	1.17	0.046"	0.1	2.8	6.3	25	10	2.5	6.8	7.0			●			
R/L 007M0117-22	1.17	0.046"	0.1	2.8	6.3	37	22	2.5	6.8	7.0			●			
R/L 007M0150-10	1.5		0.1	2.8	6.3	25	10	2.5	6.8	7.0			●			
R/L 007M0150-15	1.5		0.1	2.8	6.3	30	15	2.5	6.8	7.0			●			
R/L 007M0150-22	1.5		0.1	2.8	6.3	37	22	2.5	6.8	7.0			●			
R/L 007M0150-25	1.5		0.1	2.8	6.3	40	25	2.5	6.8	7.0			●			
R/L 007M0150-30	1.5		0.1	2.8	6.3	45	30	2.5	6.8	7.0			●			
R/L 007M0157-10	1.57	0.062"	0.1	2.8	6.3	25	10	2.5	6.8	7.0			●			
R/L 007M0157-25	1.57	0.062"	0.1	2.8	6.3	40	25	2.5	6.8	7.0			●			
↳ ...																

Weitere HM Sorten können Sie in der Sortenübersicht im Kapitel "Technische Hinweise" und der Preisliste finden.

Bestellbeispiel:  
für rechte Ausführung und Sorte  
R007M0100-10/AL41F

More carbide grades you can find in the grades summary in the chapter "technical instructions" and in the price list.

order-example:  
righthand version and grade  
R007M0100-10/AL41F





**ULTRAMINI**

Bohrungsbearbeitung  
ab  $\varnothing$  0.2 mm

grooving, boring and profiling  
starting at  $\varnothing$  0.2 mm

**Typ 007M**

Stechdrehen  
mit Eckenradius

grooving  
with corner radius

D min. 6.8 mm  
Stechtiefe t max. 2.5 mm

D min. 6.8 mm  
depth of groove t max. 2.5 mm

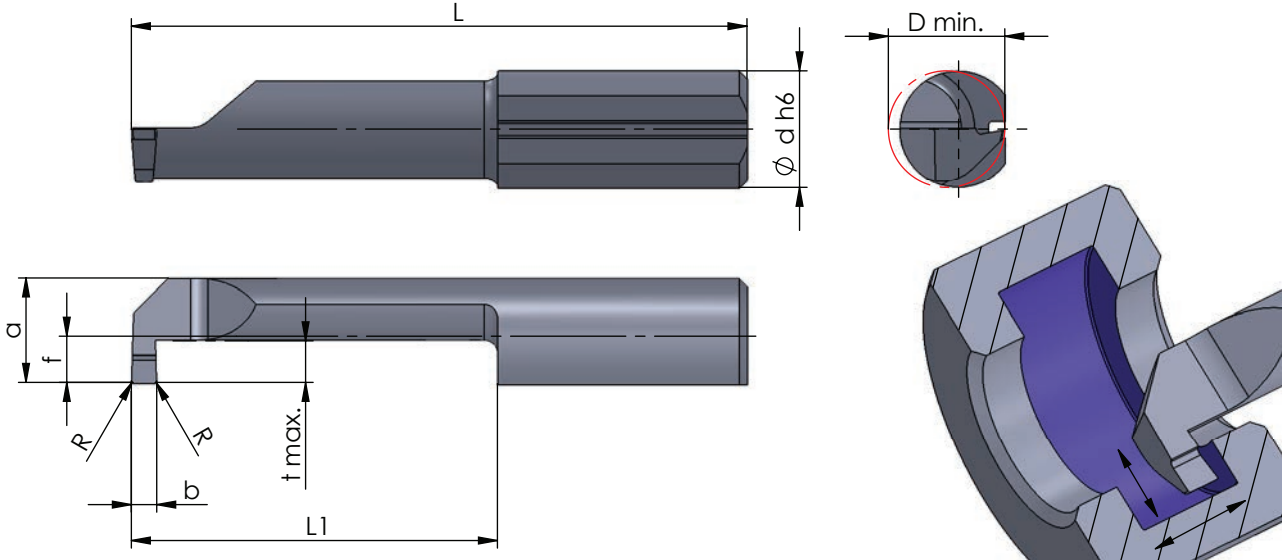

Rechts (R): wie gezeichnet  
Links (L): spiegelbildlich

righthand (R): as shown  
lefthand version (L): mirror image

Abmessungen in mm

dimensions in mm

Bestellnummer part number	b +0.05	b (inch)	R	f	a	L	L1	t max.	D min.	$\varnothing$ d h6	Klemmhalter Typ				Klemmhalter Typ toolholder type
											K10F	CN45F	AL41F	P07C	
...															
R/L 007M0198-22	1.98	0.078"	0.1	2.8	6.3	37	22	2.5	6.8	7.0		●			
R/L 007M0200-10	2.0		0.1	2.8	6.3	25	10	2.5	6.8	7.0		●			
R/L 007M0200-15	2.0		0.1	2.8	6.3	30	15	2.5	6.8	7.0		●			
R/L 007M0200-22	2.0		0.1	2.8	6.3	37	22	2.5	6.8	7.0		●			670... 676... 687... ...7
R/L 007M0200-25	2.0		0.1	2.8	6.3	40	25	2.5	6.8	7.0		●			
R/L 007M0200-30	2.0		0.1	2.8	6.3	45	30	2.5	6.8	7.0		●			

Weitere HM Sorten können Sie in der Sortenübersicht im Kapitel "Technische Hinweise" und der Preisliste finden.

Bestellbeispiel:  
für rechte Ausführung und Sorte  
R007M0200-10/AL41F

More carbide grades you can find in the grades summary in the chapter "technical instructions" and in the price list.

order-example:  
righthand version and grade  
R007M0200-10/AL41F



# ULTRAMINI

Bohrungsbearbeitung  
ab  $\varnothing$  0.2 mm

grooving, boring and profiling  
starting at  $\varnothing$  0.2 mm

# Typ 008M

Stechdrehen  
mit Eckenradius

grooving  
with corner radius

D min. 7.8 mm  
Stechtiefe t max. 3.0 mm

D min. 7.8 mm  
depth of groove t max. 3.0 mm

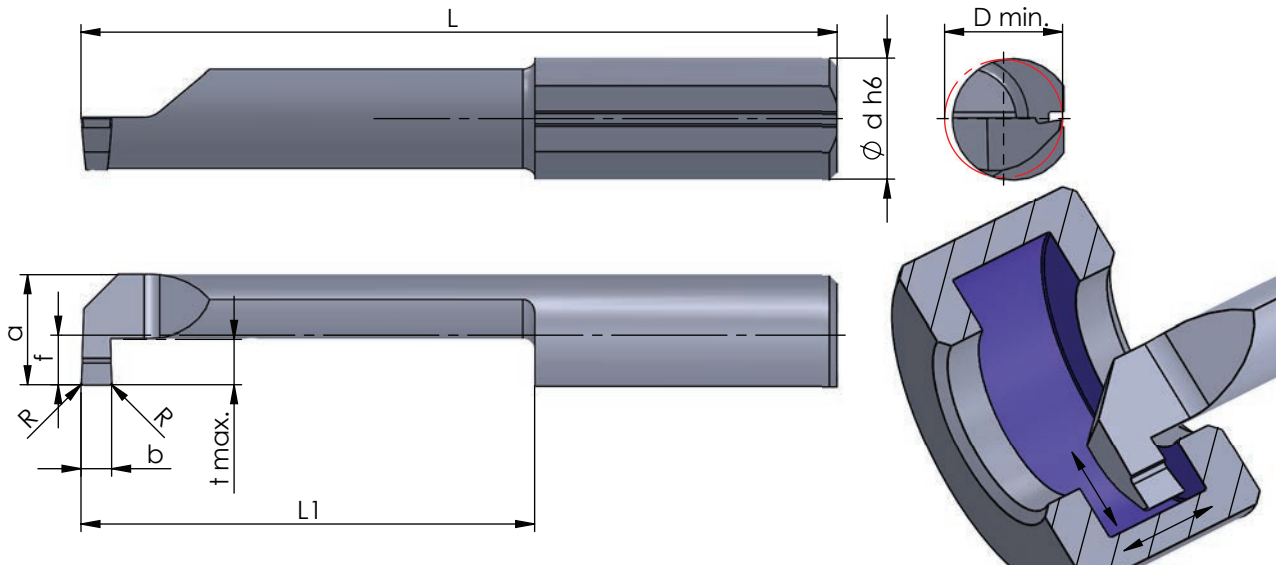

Rechts (R): wie gezeichnet  
Links (L): spiegelbildlich

righthand (R): as shown  
lefthand version (L): mirror image

Abmessungen in mm

dimensions in mm

Bestellnummer part number	b +0.05	R	f	a	L	L1	t max.	D min.	Ø d h6	Klemmhalter Typ toolholder type			
										K10F	CN45F	AL41F	P07C
R/L 008M0100-30	1.0	0.1	3.3	7.3	50	30	3.0	7.8	8.0		●		
R/L 008M0100-40	1.0	0.1	3.3	7.3	60	40	3.0	7.8	8.0		●		
R/L 008M0200-30	2.0	0.1	3.3	7.3	50	30	3.0	7.8	8.0		●		680... 681... 687... ...8
R/L 008M0200-40	2.0	0.1	3.3	7.3	60	40	3.0	7.8	8.0		●		
R/L 008M0250-30	2.5	0.1	3.3	7.3	50	30	3.0	7.8	8.0		●		
R/L 008M0250-40	2.5	0.1	3.3	7.3	60	40	3.0	7.8	8.0		●		

Weitere HM Sorten können Sie in der Sortenübersicht im Kapitel "Technische Hinweise" und der Preisliste finden.

Bestellbeispiel:  
für rechte Ausführung und Sorte  
R008M0100-30/AL41F

More carbide grades you can find in the grades summary in the chapter "technical instructions" and in the price list.

order-example:  
righthand version and grade  
R008M0100-30/AL41F

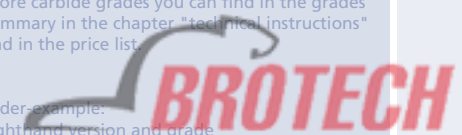

**ULTRAMINI**

Bohrungsbearbeitung  
ab  $\varnothing$  0.2 mm

grooving, boring and profiling  
starting at  $\varnothing$  0.2 mm

**Typ 10M**

Stechdrehen  
mit Eckenradius und  
innerer Kühlmittelzufuhr

grooving  
with corner radius and  
with through coolant

D min. 10.5 mm  
Stechtiefe t max. 4.0 mm

D min. 10.5 mm  
depth of groove t max. 4.0 mm

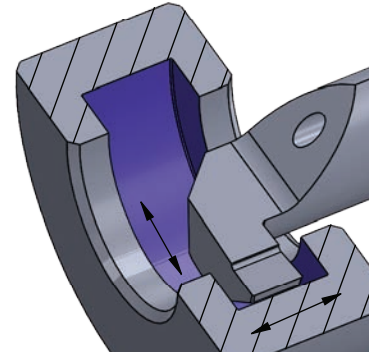
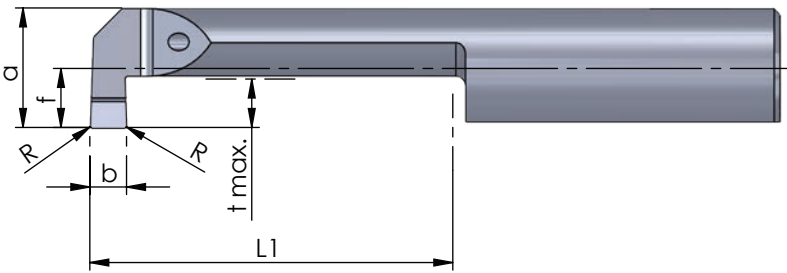
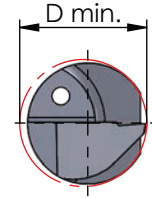
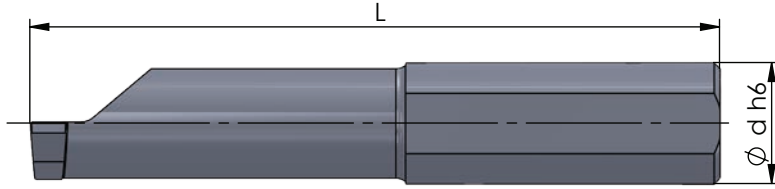

Rechts (R): wie gezeichnet  
Links (L): spiegelbildlich

righthand (R): as shown  
lefthand version (L): mirror image

Abmessungen in mm

dimensions in mm

	Bestellnummer part number	b +0.05	R	f	a	L	L1	t max.	D min.	Ø d h6					Klemmhalter Typ toolholder type
											K10F	CN45F	AL41F	P07C	
neu	R/L 10M0100-30	1.0	0.1	4.9	9.9	57	30	4.0	10.5	10		●			681...
neu	R/L 10M0100-50	1.0	0.1	4.9	9.9	77	50	4.0	10.5	10		●			
neu	R/L 10M0200-30	2.0	0.1	4.9	9.9	57	30	4.0	10.5	10		●			
neu	R/L 10M0200-50	2.0	0.1	4.9	9.9	77	50	4.0	10.5	10		●			
neu	R/L 10M0300-30	3.0	0.1	4.9	9.9	57	30	4.0	10.5	10		●			
neu	R/L 10M0300-50	3.0	0.1	4.9	9.9	77	50	4.0	10.5	10		●			

Weitere HM Sorten können Sie in der Sortenübersicht im Kapitel "Technische Hinweise" und der Preisliste finden.

Bestellbeispiel:  
für rechte Ausführung und Sorte  
R10M0100-30/AL41F

More carbide grades you can find in the grades summary in the chapter "technical instructions" and in the price list.

order-example:  
righthand version and grade  
R10M0100-30/AL41F



# ULTRAMINI

Bohrungsbearbeitung  
ab  $\varnothing$  0.2 mm

grooving, boring and profiling  
starting at  $\varnothing$  0.2 mm

# Typ 004 / 005 / 006 / 007

Stechdrehen und Kopieren  
mit Vollradius

grooving and profiling  
with full radius

D min. 4.0 mm  
Vollradius R 0.5 - 1.0

D min. 4.0 mm  
full radius R 0.5 - 1.0

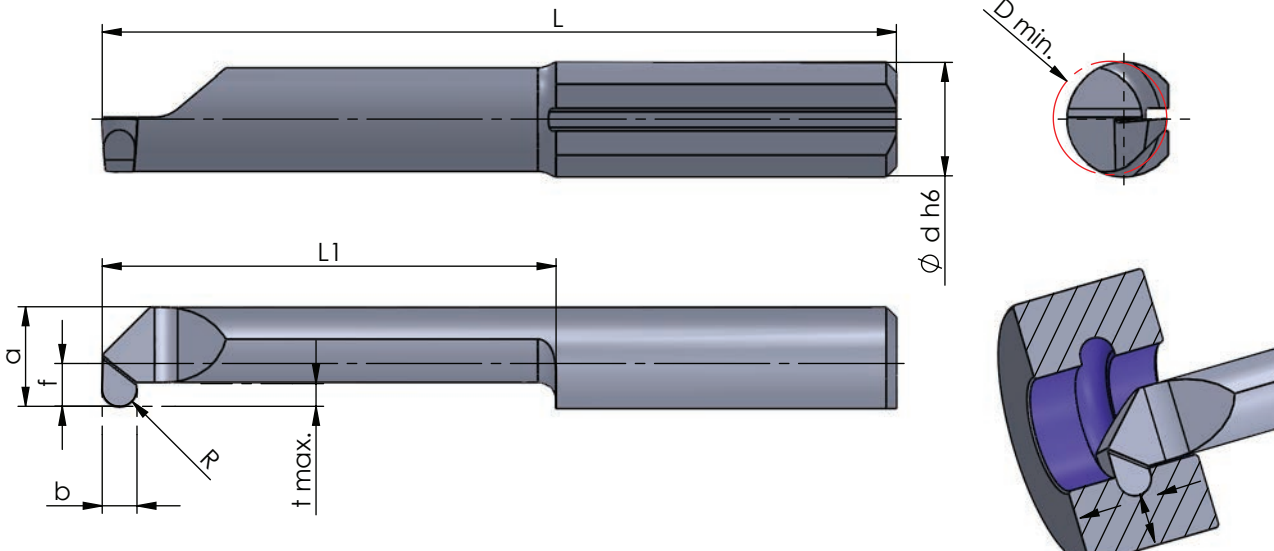

Rechts (R): wie gezeichnet  
Links (L): spiegelbildlich

righthand (R): as shown  
lefthand version (L): mirror image

Abmessungen in mm

dimensions in mm

Bestellnummer part number	b +0.05	b (inch)	R	f	a	L	L1	t max.	D min.	Ø d h6	K10F CN45F AL41F PD2F	Klemmhalter Typ toolholder type
	R/L004-0.50-16	1.0		0.5	1.5	3.5	30	16	0.8	4.0		
R/L005-0.50-20	1.0		0.5	1.9	4.4	35	20	1.0	5.0	5.0	●	645... 650... ...5
R/L005-0.58-20	1.17	0.046"	0.585	1.9	4.4	35	20	1.0	5.0	5.0	●	650... ...5
R/L005-0.75-20	1.5		0.75	1.9	4.4	35	20	1.0	5.0	5.0	●	650... ...5
R/L005-1.00-20	2.0		1.0	1.9	4.4	35	20	1.0	5.0	5.0	●	650... ...5
R/L006-0.50-25	1.0		0.5	2.3	5.3	40	25	1.8	6.0	6.0	● ● ●	660... ...6
R/L006-0.75-25	1.5		0.75	2.3	5.3	40	25	1.8	6.0	6.0	● ● ●	660... ...6
R/L006-1.00-25	2.0		1.0	2.3	5.3	40	25	1.8	6.0	6.0	● ● ●	660... ...6
R/L007-0.50-30	1.0		0.5	2.8	6.3	45	30	2.5	6.8	7.0	●	670... 687... ...7
R/L007-0.75-30	1.5		0.75	2.8	6.3	45	30	2.5	6.8	7.0	●	670... 687... ...7
R/L007-1.00-30	2.0		1.0	2.8	6.3	45	30	2.5	6.8	7.0	●	670... 687... ...7

Weitere HM Sorten können Sie in der Sortenübersicht im Kapitel "Technische Hinweise" und der Preisliste finden.

Bestellbeispiel:  
für rechte Ausführung und Sorte  
R004-0.50-16/CN45F

More carbide grades you can find in the grades summary in the chapter "technical instructions" and in the price list.

order-example:  
righthand version and grade  
R004-0.50-16/CN45F

## ULTRAMINI

Bohrungsbearbeitung  
ab  $\varnothing$  0.2 mm

grooving, boring and profiling  
starting at  $\varnothing$  0.2 mm

## Typ 060

Ausdrehen und Fasen

D min. 3.0 - 6.8 mm

boring and chamfering

D min. 3.0 - 6.8 mm

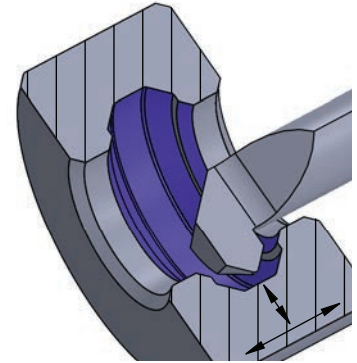
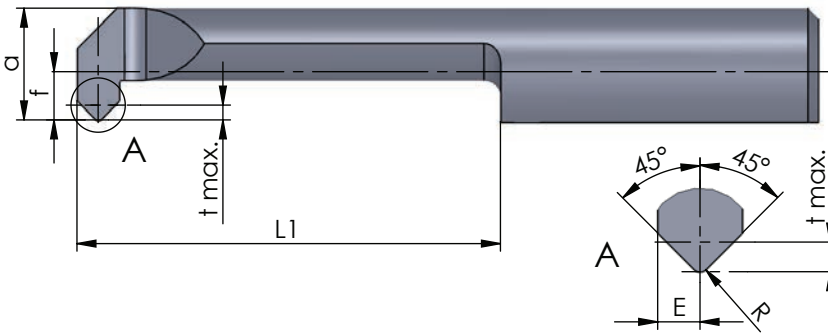
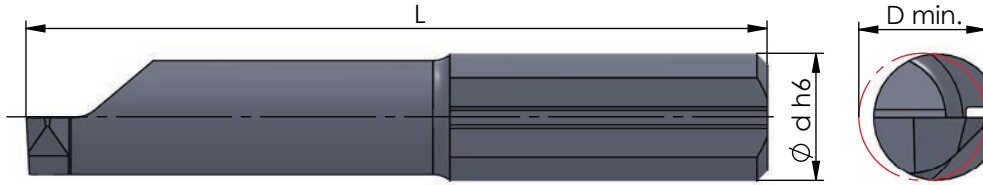

Rechts (R): wie gezeichnet  
Links (L): spiegelbildlich

righthand (R): as shown  
lefthand version (L): mirror image

Abmessungen in mm

dimensions in mm

Bestellnummer part number	E	R	f	a	L	L1	t max.	D min.	Ø d h6	K10F	CN45F	AL41F	P07C	Klemmhalter Typ	toolholder type
R/L 060.3-10	1	0.2	0.7	2.7	24	10	0.4	3.0	4	●	●			645...	640... ...4
R/L 060.4-16	1	0.2	1.5	3.5	30	16	0.5	4.0	4	●	●				650... ...5
R/L 060.5-15	1	0.2	1.9	4.4	30	15	0.7	5.0	5	●	●			676...	660... ...6
R/L 060.5-20	1	0.2	1.9	4.4	35	20	0.7	5.0	5	●	●				670... 687... ...7
R/L 060.6-20	1	0.2	2.3	5.3	35	20	0.7	6.0	6	●	●				
R/L 060.6-25	1	0.2	2.3	5.3	40	25	0.7	6.0	6	●	●				
R/L 060.7-20	1	0.2	2.8	6.3	35	20	0.7	6.8	7	●	●				
R/L 060.7-40	1	0.2	2.8	6.3	55	40	0.7	6.8	7	●	●				

Weitere HM Sorten können Sie in der Sortenübersicht im Kapitel "Technische Hinweise" und der Preisliste finden.

Bestellbeispiel:  
für rechte Ausführung und Sorte  
R060.5-15/CN45F

More carbide grades you can find in the grades summary in the chapter "technical instructions" and in the price list.

order example:  
righthand version and grade  
R060.5-15/CN45F

**BROTECH**

# ULTRAMINI

Bohrungsbearbeitung  
ab  $\varnothing 0.2 \text{ mm}$

grooving, boring and profiling  
starting at  $\varnothing 0.2 \text{ mm}$

# Typ 070

Vorstechen und Fasen

D min. 4.0 - 6.0 mm

pregrooving and chamfering

D min. 4.0 - 6.0 mm

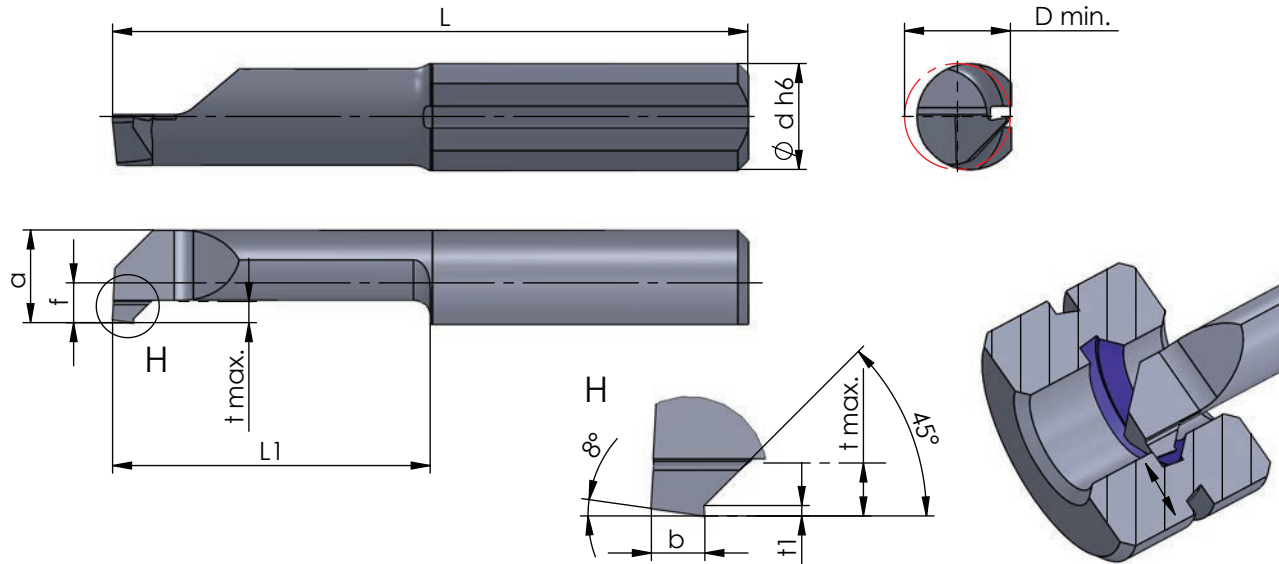

Rechts (R): wie gezeichnet  
Links (L): spiegelbildlich

righthand (R): as shown  
lefthand version (L): mirror image

Abmessungen in mm

dimensions in mm

Bestellnummer part number	b	f	a	L	L1	t max.	D min.	$\varnothing d h6$	K10F CN45F AL41F P07C	Klemmhalter Typ toolholder type	
										645...	640... ...4 650... ...5
R/L 070.4-10	1.0	1.5	3.5	25	10	0.8	4.0	4.0	● ●		
R/L 070.4-16	1.0	1.5	3.5	30	16	0.8	4.0	4.0	● ●		
R/L 070.5-15	1.0	1.9	4.4	30	15	1.0	5.0	5.0	● ●	645...	
R/L 070.5-20	1.0	1.9	4.4	35	20	1.0	5.0	5.0	● ●		640... ...4
R/L 070.5-30	1.0	1.9	4.4	45	30	1.0	5.0	5.0	● ●		650... ...5
R/L 070.6-30	1.0	2.3	5.3	45	30	1.0	6.0	6.0	● ●		
R/L 070.6-42	1.0	2.3	5.3	57	42	1.0	6.0	6.0	● ●	660... 676... ...6	

Weitere HM Sorten können Sie in der Sortenübersicht im Kapitel "Technische Hinweise" und der Preisliste finden.

Bestellbeispiel:  
für rechte Ausführung und Sorte  
R070.4-10/CN45F

More carbide grades you can find in the grades summary in the chapter "technical instructions" and in the price list.

order-example:  
righthand version and grade  
R070.4-10/CN45F



## ULTRAMINI

Bohrungsbearbeitung  
ab  $\varnothing$  0.2 mm

grooving, boring and profiling  
starting at  $\varnothing$  0.2 mm

## Impressionen

impressions

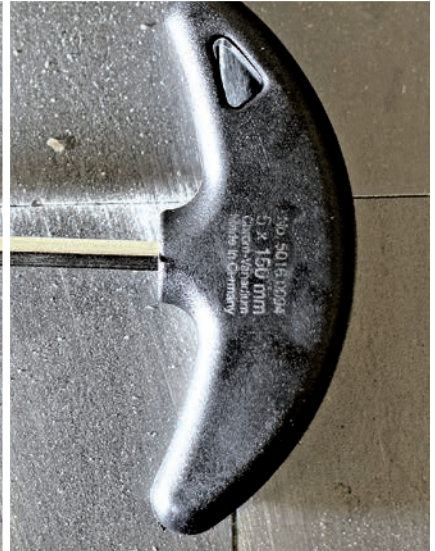
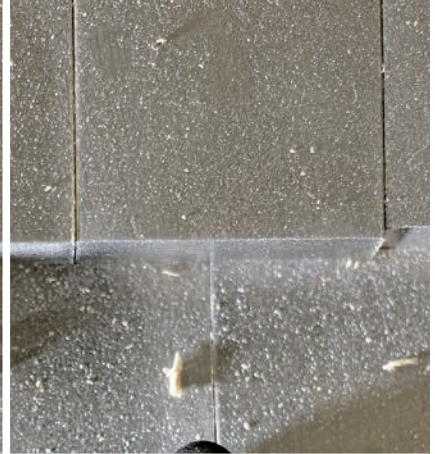

# ULTRAMINI

Bohrungsbearbeitung  
ab  $\varnothing 0.2 \text{ mm}$

grooving, boring and profiling  
starting at  $\varnothing 0.2 \text{ mm}$

# Typ Gewindedrehen

metrisches ISO-Gewinde,  
Teilprofil, innen

type threading,  
metric ISO-thread,  
partial profile, internal

D min. 1.56 - 7.0 mm  
Steigung P = 0.4 - 1.75

D min. 1.56 - 7.0 mm  
pitch P = 0.4 - 1.75

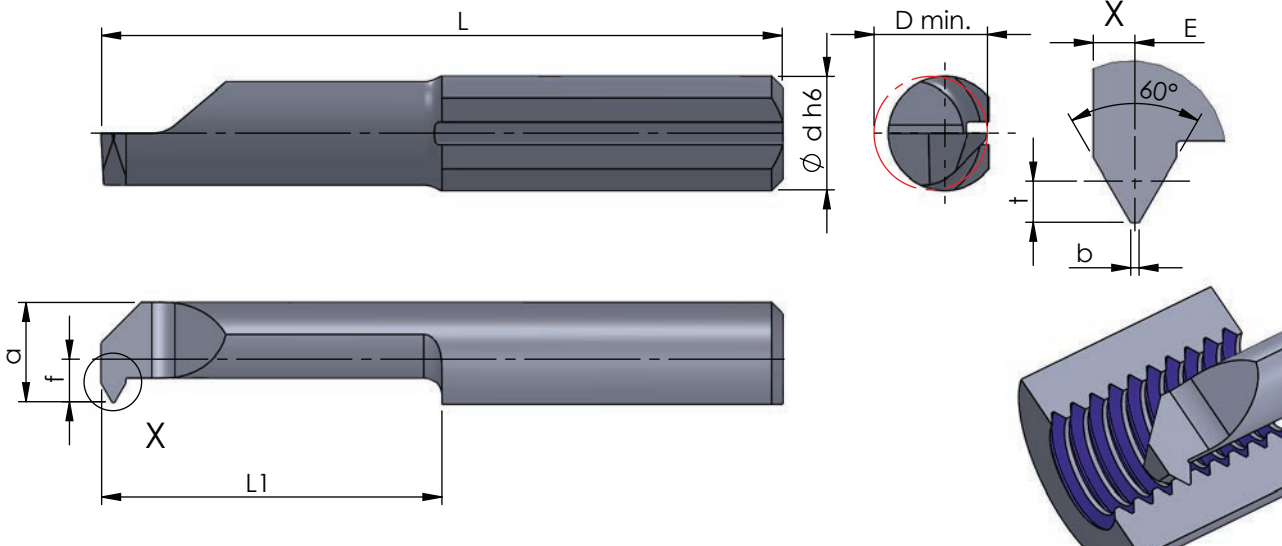

Rechts (R): wie gezeichnet  
Links (L): spiegelbildlich

righthand (R): as shown  
lefthand version (L): mirror image

Abmessungen in mm

dimensions in mm

Bestellnummer part number	Steigung P pitch P	Regelgewinde / standard thread									D min.	$\varnothing d h6$	Klemmhalter Typ				Klemmhalter Typ toolholder type
			t	E	b	f	a	L	L1	K10F			CN45F	AL41F	PD2F		
R/L 002.0204-5	0.4 - 0.45	M2	0.22	0.2	0.05		1.4	20	5	1.56	4.0		●				645... 640... ...4
R/L 002.02045-6	0.45 - 0.5	M2.5	0.24	0.22	0.06		1.45	22	6	1.7	4.0		●				
R/L 003.0105-8	0.5 - 0.7	M3	0.27	0.33	0.04	0.3	2.3	22	8	2.4	4.0		●				
R/L 004.0105-10	0.5 - 0.75		0.27	0.44	0.09	1.0	3.0	24	10	3.2	4.0		●				
R/L 004.0307-10	0.7 - 0.8	M4	0.32	0.32	0.09	0.9	2.9	24	10	3.2	4.0		●				
R/L 004.0205-15	0.5 - 0.75		0.27	0.35	0.06	1.5	3.5	30	15	4.0	4.0	●	●				
R/L 004.0408-15	0.8 - 1.0	M5	0.43	0.45	0.10	1.5	3.5	30	15	4.0	4.0		●			650... ...5	
R/L 005.0205-15	0.5 - 0.75		0.27	0.35	0.06	1.9	4.4	30	15	5.0	5.0	●	●				
R/L 005.0205-20	0.5 - 0.75		0.27	0.35	0.06	1.9	4.4	35	20	5.0	5.0	●	●				
R/L 005.0407-15	0.75 - 1.0		0.4	0.45	0.09	1.9	4.4	30	15	5.0	5.0	●	●				
R/L 005.0407-20	0.75 - 1.0		0.4	0.45	0.09	1.9	4.4	35	20	5.0	5.0	●	●				
R/L 005.0510-15	1.0 - 1.25	M6	0.55	0.55	0.12	1.9	4.4	30	15	5.0	5.0	●	●				
R/L 005.0510-20	1.0 - 1.25	M6	0.55	0.55	0.12	1.9	4.4	35	20	5.0	5.0	●	●				
L → ...																	

Weitere HM Sorten können Sie in der Sortenübersicht im Kapitel "Technische Hinweise" und der Preisliste finden.

Bestellbeispiel:  
für rechte Ausführung und Sorte  
R002.0204-5/AL41F

### weitere Informationen:

- siehe Technische Hinweise

### more informations:

- look at the technical instructions

More carbide grades you can find in the grades summary in the chapter "technical instructions" and in the price list.

order-example:  
righthand version and grade  
R002.0204-5/AL41F

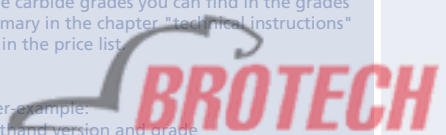



## ULTRAMINI

Bohrungsbearbeitung  
ab  $\varnothing 0.2$  mm

grooving, boring and profiling  
starting at  $\varnothing 0.2$  mm

## Typ Gewindedrehen

metrisches ISO-Gewinde,  
Teilprofil, innen

type threading,  
metric ISO-thread,  
partial profile, internal

D min. 1.56 - 7.0 mm  
Steigung P = 0.4 - 1.75

D min. 1.56 - 7.0 mm  
pitch P = 0.4 - 1.75

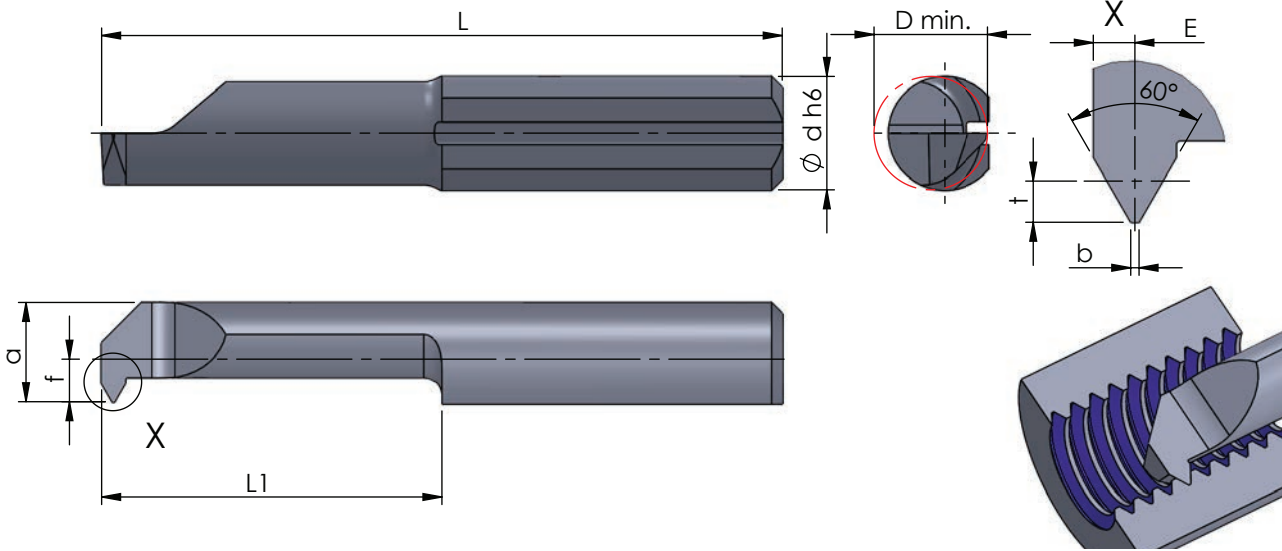

Rechts (R): wie gezeichnet  
Links (L): spiegelbildlich

righthand (R): as shown  
lefthand version (L): mirror image

Abmessungen in mm

dimensions in mm

Bestellnummer part number	Steigung P pitch P	Regelgewinde / standard thread									D min.	$\varnothing$ d h6	Klemmhalter Typ				Klemmhalter Typ toolholder type	
			t	E	b	f	a	L	L1	K10F			CN45F	AL41F	PD2F			
...																		
R/L 006.0510-15	1.0 - 1.25		0.55	0.55	0.12	2.3	5.3	30	15	6.0	6.0	●	●					
R/L 006.0510-22	1.0 - 1.25		0.55	0.55	0.12	2.3	5.3	37	22	6.0	6.0	●	●					
R/L 006.0612-15	1.25 - 1.5	M8	0.68	0.65	0.15	2.3	5.3	30	15	6.0	6.0	●	●					660... ...6
R/L 006.0612-22	1.25 - 1.5	M8	0.68	0.65	0.15	2.3	5.3	37	22	6.0	6.0	●						
R/L 006.0815-15	1.5 - 1.75	M10	0.81	0.75	0.18	2.3	5.3	30	15	6.0	6.0	●	●					676...
R/L 006.0815-22	1.5 - 1.75	M10	0.81	0.75	0.18	2.3	5.3	37	22	6.0	6.0	●	●					
R/L 007.0815-15	1.5 - 1.75	M10	0.81	0.75	0.18	2.7	6.3	30	15	7.0	7.0	●	●					670... 687... ...7
R/L 007.0815-25	1.5 - 1.75	M10	0.81	0.75	0.18	2.7	6.3	40	25	7.0	7.0	●						

Weitere HM Sorten können Sie in der Sortenübersicht im Kapitel "Technische Hinweise" und der Preisliste finden.

Bestellbeispiel:  
für rechte Ausführung und Sorte  
R006.0510-15/AL41F

### weitere Informationen:

- siehe Technische Hinweise

### more informations:

- look at the technical instructions

More carbide grades you can find in the grades summary in the chapter "technical instructions" and in the price list.

order-example:  
righthand version and grade  
R006.0510-15/AL41F



## ULTRAMINI

Bohrungsbearbeitung  
ab  $\varnothing 0.2$  mm

grooving, boring and profiling  
starting at  $\varnothing 0.2$  mm

## Typ Gewindedrehen

metrisches ISO-Gewinde,  
Vollprofil, innen

type threading,  
metric ISO-thread,  
full profile, internal

D min. 4.0 - 7.0 mm  
Steigung P = 0.5 - 1.5

D min. 4.0 - 7.0 mm  
pitch P = 0.5 - 1.5

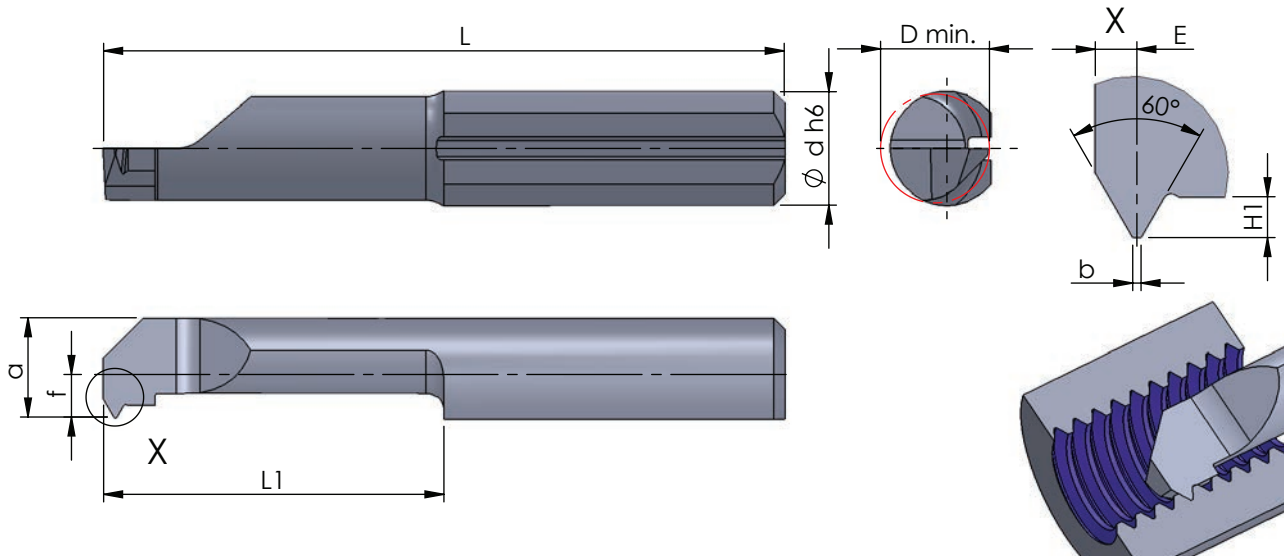

Rechts (R): wie gezeichnet  
Links (L): spiegelbildlich

righthand (R): as shown  
lefthand version (L): mirror image

Abmessungen in mm

dimensions in mm

Bestellnummer part number	Steigung P pitch P	Regelgewinde / standard thread	H1	E	b	f	a	L	L1	D min.	$\varnothing$ d h6	Klemmhalter Typ				Klemmhalter Typ	toolholder type
												K10F	CN45F	AL41F	PD2F		
R/L 104.0205-15	0.5		0.27	0.35	0.06	1.5	3.5	30	15	4.0	4.0		●				640... ...4
R/L 104.0408-15	0.8	M5	0.43	0.5	0.1	1.5	3.5	30	15	4.0	4.0		●				640... ...4
R/L 105.0205-15	0.5		0.27	0.35	0.06	1.9	4.4	30	15	5.0	5.0		●		645...		640... ...4
R/L 105.0407-15	0.75		0.40	0.45	0.09	1.9	4.4	30	15	5.0	5.0		●		645...		640... ...4
R/L 105.0408-15	0.8		0.43	0.50	0.10	1.9	4.4	30	15	4.8	5.0		●		645...		650... ...5
R/L 105.0510-15	1.0	M6	0.54	0.55	0.12	1.9	4.4	30	15	4.8	5.0		●		645...		650... ...5
R/L 106.0510-15	1.0		0.54	0.55	0.12	2.3	5.3	30	15	6.0	6.0		●		676...		660... ...6
R/L 106.0612-15	1.25	M8	0.67	0.65	0.15	2.3	5.3	30	15	6.0	6.0		●		676...		660... ...6
R/L 106.0815-15	1.5	M10	0.81	0.75	0.18	2.3	5.3	30	15	6.0	6.0		●		676...		660... ...6
R/L 107.0815-15	1.5	M10	0.81	0.75	0.18	2.8	6.3	30	15	7.0	7.0		●		676...		670... 687... ...7

Weitere HM Sorten können Sie in der Sortenübersicht im Kapitel "Technische Hinweise" und der Preisliste finden.

Bestellbeispiel:  
für rechte Ausführung und Sorte  
R104.0205-15/AL41F

### weitere Informationen:

- siehe Technische Hinweise

### more informations:

- look at the technical instructions

More carbide grades you can find in the grades summary in the chapter "technical instructions" and in the price list.

order-example:  
righthand version and grade  
R104.0205-15/AL41F

**BROTECH**

## ULTRAMINI

Bohrungsbearbeitung  
ab  $\varnothing$  0.2 mm

grooving, boring and profiling  
starting at  $\varnothing$  0.2 mm

## Typ Gewindedrehen

Whitworth-Gewinde,  
Teilprofil, innen

D min. 4.8 - 7.0 mm

type threading,  
Whitworth thread,  
partial profile, internal

D min. 4.8 - 7.0 mm

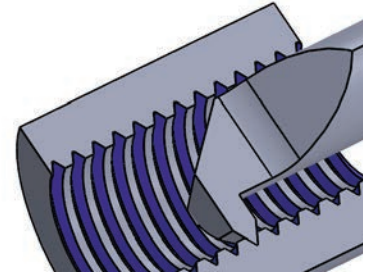
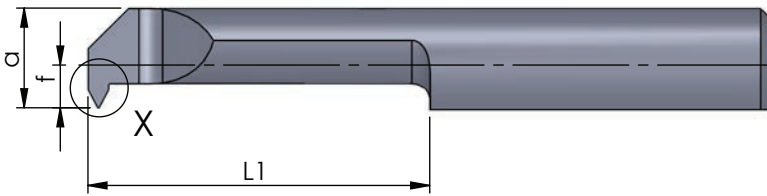
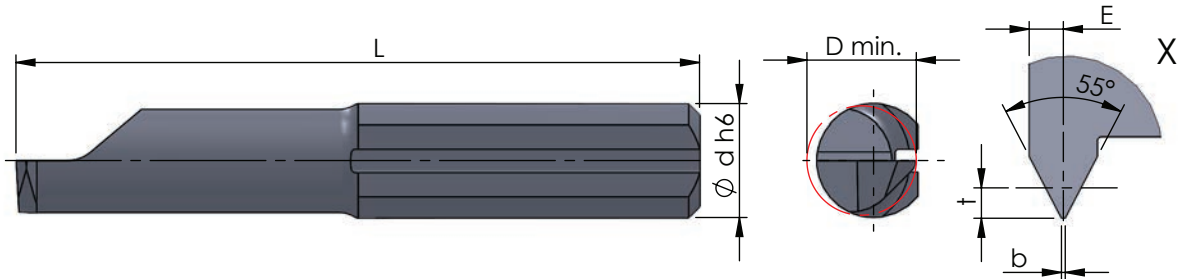

Rechts (R): wie gezeichnet  
Links (L): spiegelbildlich

righthand (R): as shown  
lefthand version (L): mirror image

Abmessungen in mm

dimensions in mm

Bestellnummer part number	Gang / Zoll threads / inch	t	E	b	f	a	L	L1	D min.	$\varnothing$ d h6	Klemmhalter Typ				Klemmhalter Typ toolholder type
											K10F	CN45F	AL41F	PD2F	
R/L 005.5548-15	48 - 24	0.40	0.45	0.06	1.9	4.4	30	15	4.8	5.0	●				645... 650... ...5
R/L 006.5548-15	48 - 24	0.40	0.45	0.06	2.3	5.3	30	15	6.0	6.0	●				
R/L 006.5524-15	24 - 16	0.81	0.75	0.12	2.3	5.3	30	15	6.0	6.0	●				
R/L 007.5524-15	24 - 16	0.81	0.75	0.12	2.8	6.3	30	15	7.0	7.0	●				676... 670... 687... ...7

Weitere HM Sorten können Sie in der Sortenübersicht im Kapitel "Technische Hinweise" und der Preisliste finden.

Bestellbeispiel:  
für rechte Ausführung und Sorte  
R005.5548-15/CN45F

### weitere Informationen:

- siehe Technische Hinweise

### more informations:

- look at the technical instructions

More carbide grades you can find in the grades summary in the chapter "technical instructions" and in the price list.

order-example:  
righthand version and grade  
R005.5548-15/CN45F

**BROTECH**

# ULTRAMINI

Bohrungsbearbeitung  
ab  $\varnothing$  0.2 mm

grooving, boring and profiling  
starting at  $\varnothing$  0.2 mm

# Typ Gewindedrehen

Whitworth-Gewinde,  
Vollprofil, innen

D min. 6.0 mm

type threading,  
Whitworth thread,  
full profile, internal

D min. 6.0 mm

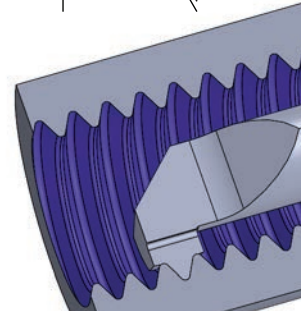
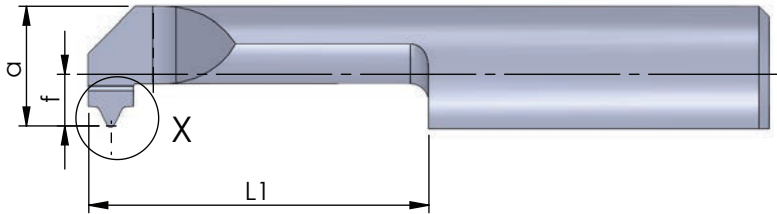
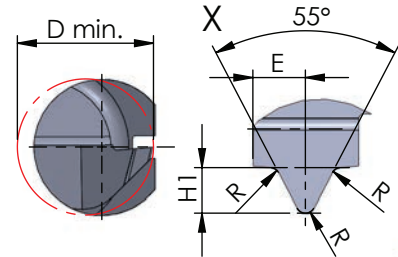
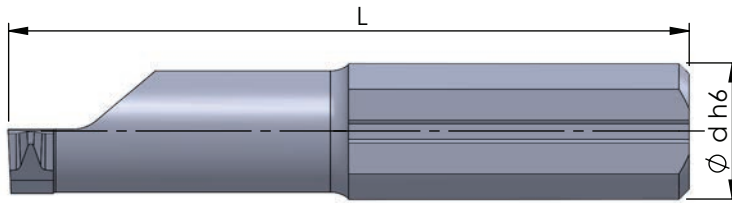

Rechts (R): wie gezeichnet  
Links (L): spiegelbildlich

righthand (R): as shown  
lefthand version (L): mirror image

Abmessungen in mm

dimensions in mm

Bestellnummer part number	Steigung P pitch P	Gang / Zoll threads / inch	H1	R	E	f	a	L	L1	D min.	Ø d h6	Klemmhalter Typ toolholder type				
												K10F	CN45F	AL41F	PD2F	
R/L 106.5519-15	1.336	19	0.86	0.18	1	2.3	5.3	30	15	6.0	6.0	●				
R/L 106.5522-15	1.154	22	0.74	0.16	1	2.3	5.3	30	15	6.0	6.0	●			660,...	676,...
R/L 106.5528-15	0.907	28	0.58	0.12	0.8	2.3	5.3	30	15	6.0	6.0	●			...	...6

Weitere HM Sorten können Sie in der Sortenübersicht im Kapitel "Technische Hinweise" und der Preisliste finden.

Bestellbeispiel:  
für rechte Ausführung und Sorte  
R106.5519-15/AL41F

### weitere Informationen:

- siehe Technische Hinweise

### more informations:

- look at the technical instructions

More carbide grades you can find in the grades summary in the chapter "technical instructions" and in the price list.

order-example:  
righthand version and grade  
R106.5519-15/AL41F

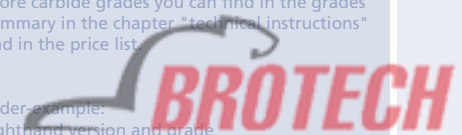

## ULTRAMINI

Bohrungsbearbeitung  
ab  $\varnothing 0.2 \text{ mm}$

grooving, boring and profiling  
starting at  $\varnothing 0.2 \text{ mm}$

## Typ Gewindedrehen

NPT-Gewinde,  
Teilprofil, innen

D min. 6.0 mm

type threading,  
NPT thread,  
partial profile, internal

D min. 6.0 mm

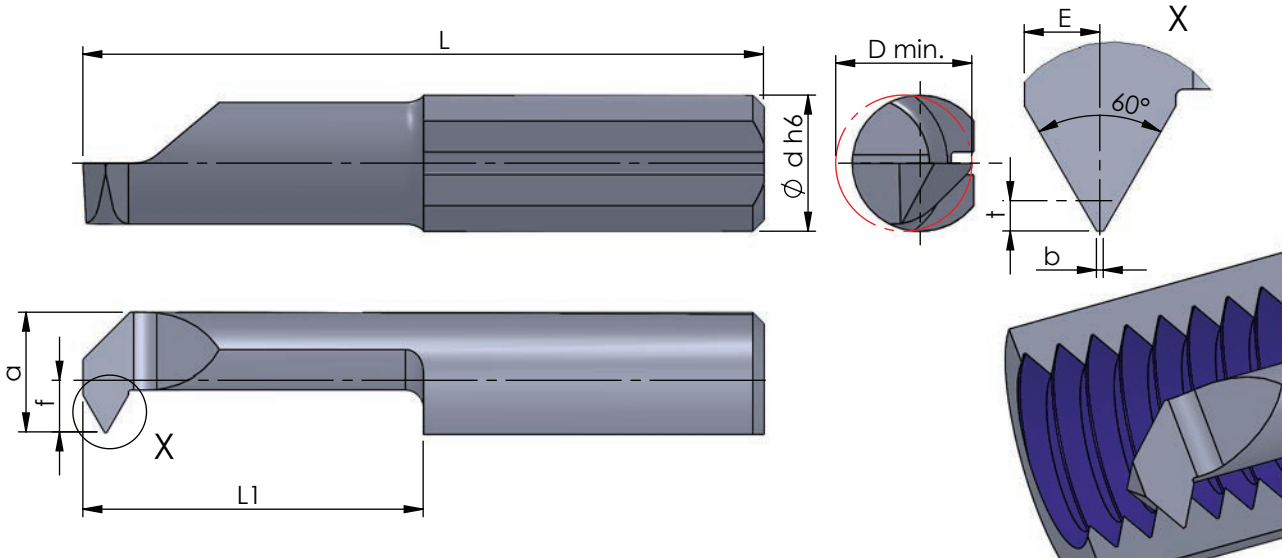

Rechts (R): wie gezeichnet  
Links (L): spiegelbildlich

righthand (R): as shown  
lefthand version (L): mirror image

Abmessungen in mm

dimensions in mm

Bestellnummer part number	Steigung P pitch P	Gang / Zoll threads / inch								D min.	Ø d h6	Klemmhalter Typ toolholder type				
			t	E	b	f	a	L	L1			K10F	CN45F	AL41F	PD2F	
R/L 006.NP18-15	1.411	18	1.35	1	0.09	2.3	5.3	30	15	6.0	6.0		●			
R/L 006.NP18-22	1.411	18	1.35	1	0.09	2.3	5.3	37	22	6.0	6.0		●			
R/L 006.NP27-15	0.940	27	1	0.8	0.06	2.3	5.3	30	15	6.0	6.0		●			660... 676... ...6
R/L 006.NP27-22	0.940	27	1	0.8	0.06	2.3	5.3	37	22	6.0	6.0		●			

Weitere HM Sorten können Sie in der Sortenübersicht im Kapitel "Technische Hinweise" und der Preisliste finden.

Bestellbeispiel:  
für rechte Ausführung und Sorte  
R006.NP18-15/AL41F

### weitere Informationen:

- siehe Technische Hinweise

### more informations:

- look at the technical instructions

More carbide grades you can find in the grades summary in the chapter "technical instructions" and in the price list.

order-example:  
righthand version and grade  
R006.NP18-15/AL41F

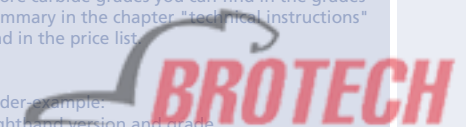

# ULTRAMINI

Bohrungsbearbeitung  
ab  $\varnothing 0.2 \text{ mm}$

grooving, boring and profiling  
starting at  $\varnothing 0.2 \text{ mm}$

# Typ Gewindedrehen

Trapezgewinde,  
Teilprofil, innen

type threading,  
trapezoidal thread,  
partial profile, internal

D min. 7.0 mm  
Steigung P = 2.0 - 3.0

D min. 7.0 mm  
pitch P = 2.0 - 3.0

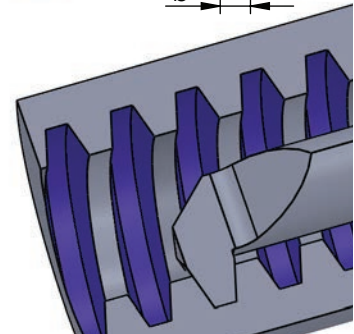
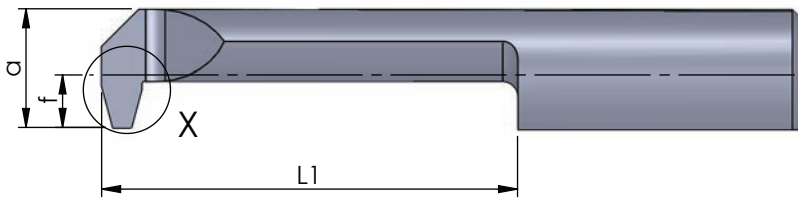
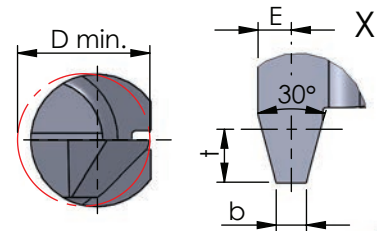
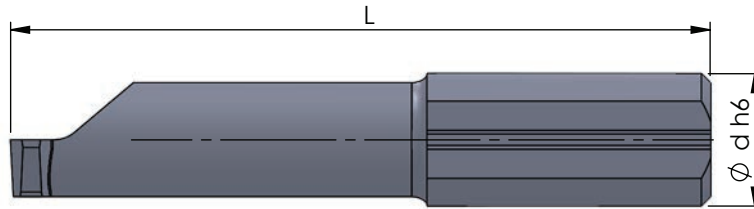

Rechts (R): wie gezeichnet  
Links (L): spiegelbildlich

righthand (R): as shown  
lefthand version (L): mirror image

Abmessungen in mm

dimensions in mm

Bestellnummer part number	Steigung P pitch P	t	E	b	f	a	L	L1	D min.	Ø d h6	Klemmhalter Typ toolholder type			
											K10F	CN45F	AL41F	PD2F
R/L 007.1220-22	2	1.25	0.75	0.6	2.8	6.3	37	22	7.0	7.0		●		
R/L 007.1220-30	2	1.25	0.75	0.6	2.8	6.3	45	30	7.0	7.0		●		670, ... 676, ... 687, ... ...7
R/L 007.1730-22	3	1.75	1.10	1.0	2.8	6.3	37	22	7.0	7.0		●		
R/L 007.1730-30	3	1.75	1.10	1.0	2.8	6.3	45	30	7.0	7.0		●		

Weitere HM Sorten können Sie in der Sortenübersicht im Kapitel "Technische Hinweise" und der Preisliste finden.

Bestellbeispiel:  
für rechte Ausführung und Sorte  
R007.1220-22/AL41F

**weitere Informationen:**  
• siehe Technische Hinweise

**more informations:**  
• look at the technical instructions

More carbide grades you can find in the grades summary in the chapter "technical instructions" and in the price list.

order-example:  
righthand version and grade  
R007.1220-22/AL41F

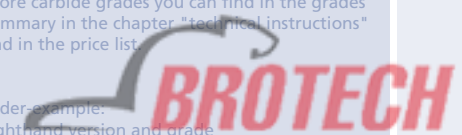

## ULTRAMINI

Bohrungsbearbeitung  
ab  $\varnothing$  0.2 mm

grooving, boring and profiling  
starting at  $\varnothing$  0.2 mm

## Impressionen

impressions

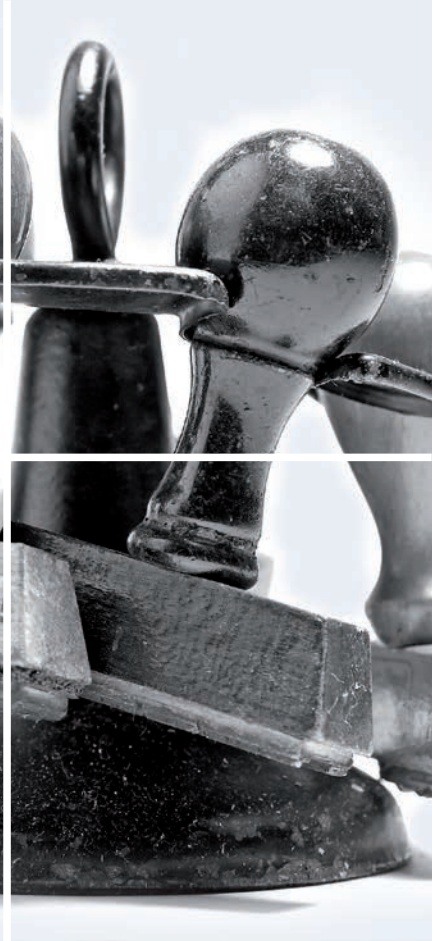

# ULTRAMINI

Bohrungsbearbeitung  
ab  $\varnothing 0.2 \text{ mm}$

grooving, boring and profiling  
starting at  $\varnothing 0.2 \text{ mm}$

# Typ 510M

Axialstechen  
mit Eckenradius

face grooving  
with corner radius

D min. 5.0 mm  
Stechtiefe t max. 4.0 mm  
Nutbreite bis 2.0 mm

D min. 5.0 mm  
depth of groove t max. 4.0 mm  
width of groove up to 2.0 mm

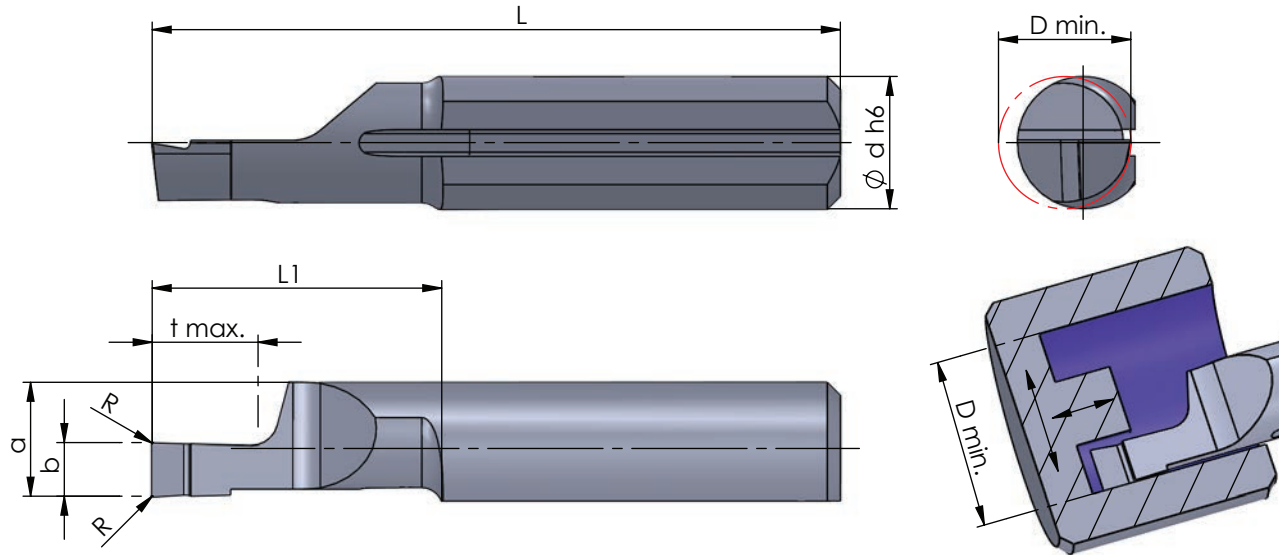

Rechts (R): wie gezeichnet  
Links (L): spiegelbildlich

righthand (R): as shown  
lefthand version (L): mirror image

Abmessungen in mm

dimensions in mm

Bestellnummer part number	b +0.05	a	L	L1	t max.	D min.	$\varnothing d h6$	R	Klemmhalter Typ toolholder type				
									K10F	CN45F	AL41F	P07C	
R/L 510M1008-10	1.0	4.3	26	11	2.0	5.0	5.0	0.05			●		
R/L 510M1508-10	1.5	4.3	26	11	3.0	5.0	5.0	0.05			●		
R/L 510M2008-10	2.0	4.3	26	11	4.0	5.0	5.0	0.05			●		
R/L 510M1008-20	1.0	4.3	35	20	2.0	5.0	5.0	0.05			●		645... 650... ...5
R/L 510M1508-20	1.5	4.3	35	20	3.0	5.0	5.0	0.05			●		
R/L 510M2008-20	2.0	4.3	35	20	4.0	5.0	5.0	0.05			●		

Weitere HM Sorten können Sie in der Sortenübersicht im Kapitel "Technische Hinweise" und der Preisliste finden.

Bestellbeispiel:  
für rechte Ausführung und Sorte  
R510M1008-10/AL41F

More carbide grades you can find in the grades summary in the chapter "technical instructions" and in the price list.

order-example:  
righthand version and grade  
R510M1008-10/AL41F

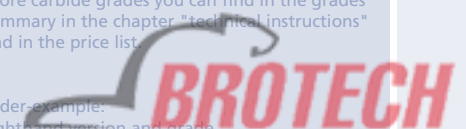



**ULTRAMINI**

Bohrungsbearbeitung  
ab  $\varnothing$  0.2 mm

grooving, boring and profiling  
starting at  $\varnothing$  0.2 mm

**Typ 610**

Axialstechen

face grooving

D min. 6.0 mm  
Stechtiefe t max. 3.5 mm  
Nutbreite bis 3.0 mm

D min. 6.0 mm  
depth of groove tmax. 3.5 mm  
width of groove up to 3.0 mm

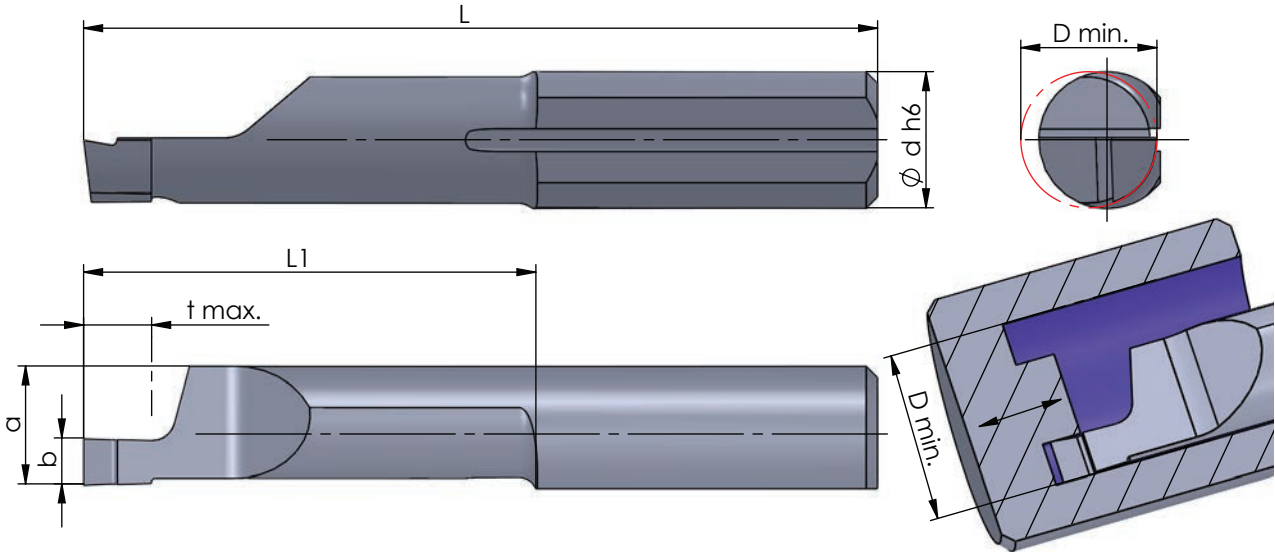

Rechts (R): wie gezeichnet  
Links (L): spiegelbildlich

righthand (R): as shown  
lefthand version (L): mirror image

Abmessungen in mm

dimensions in mm

Bestellnummer part number	b +0.05	a	L	L1	t max.	D min.	Ø d h6	K10F	CN45F	AL41F	P07C	Klemmhalter Typ	toolholder type
R/L 610.1008-10	1.0	5.2	26	11	1.5	6.0	6.0	●	●	●		660... 676... ...6	
R/L 610.1508-10	1.5	5.2	26	11	2.5	6.0	6.0		●	●			
R/L 610.2008-10	2.0	5.2	26	11	3.0	6.0	6.0	●	●	●			
R/L 610.2508-10	2.5	5.2	26	11	3.5	6.0	6.0		●	●			
R/L 610.3008-10	3.0	5.2	26	11	3.5	6.0	6.0	●	●	●			
R/L 610.1008-20	1.0	5.2	35	20	1.5	6.0	6.0	●	●	●			
R/L 610.1508-20	1.5	5.2	35	20	2.5	6.0	6.0		●	●			
R/L 610.2008-20	2.0	5.2	35	20	3.0	6.0	6.0	●	●	●			
R/L 610.2508-20	2.5	5.2	35	20	3.5	6.0	6.0		●	●			
R/L 610.3008-20	3.0	5.2	35	20	3.5	6.0	6.0		●	●			
R/L 610.1008-30	1.0	5.2	45	30	1.5	6.0	6.0		●	●			
R/L 610.1508-30	1.5	5.2	45	30	2.5	6.0	6.0		●	●			
R/L 610.2008-30	2.0	5.2	45	30	3.0	6.0	6.0		●	●			
R/L 610.2508-30	2.5	5.2	45	30	3.5	6.0	6.0		●	●			
R/L 610.3008-30	3.0	5.2	45	30	3.5	6.0	6.0	●	●	●			

Weitere HM Sorten können Sie in der Sortenübersicht im Kapitel "Technische Hinweise" und der Preisliste finden.

Bestellbeispiel:  
für rechte Ausführung und Sorte  
R610.1008-10/AL41F

More carbide grades you can find in the grades summary in the chapter "technical instructions" and in the price list.

order example:  
righthand version and grade  
R610.1008-10/AL41F



# ULTRAMINI

Bohrungsbearbeitung  
ab  $\varnothing 0.2 \text{ mm}$

grooving, boring and profiling  
starting at  $\varnothing 0.2 \text{ mm}$

# Typ 610M

Axialstechen  
mit Eckenradius

face grooving  
with corner radius

D min. 6.0 mm  
Stechtiefe t max. 6.0 mm  
Nutbreite bis 3.0 mm

D min. 6.0 mm  
depth of groove t max. 6.0 mm  
width of groove up to 3.0 mm

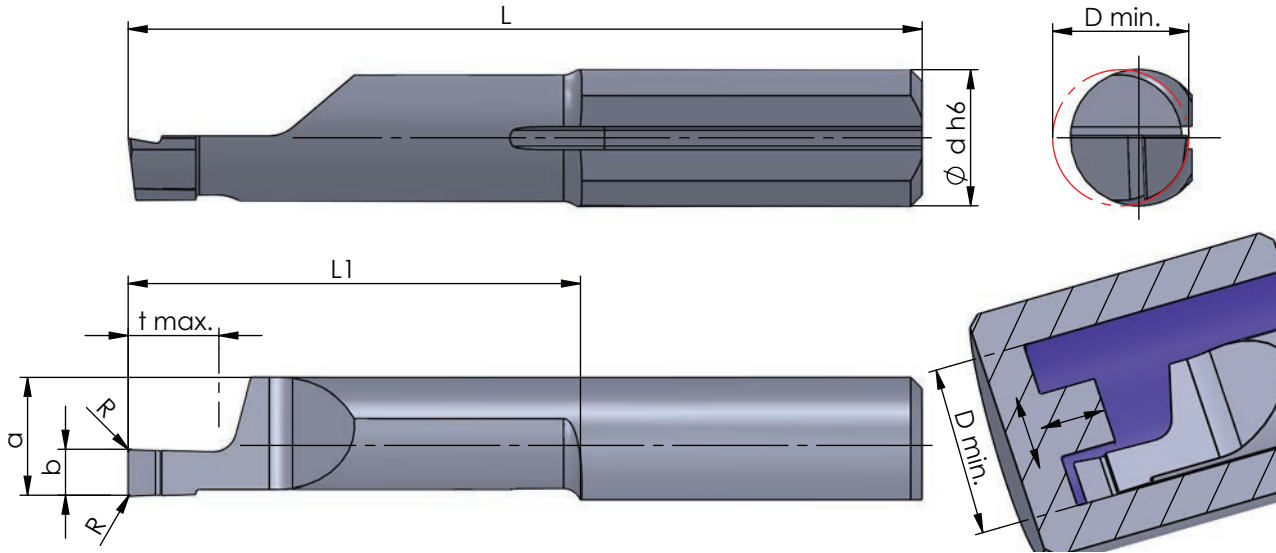

Rechts (R): wie gezeichnet  
Links (L): spiegelbildlich

righthand (R): as shown  
lefthand version (L): mirror image

Abmessungen in mm

dimensions in mm

Bestellnummer part number	b +0.05	a	L	L1	t max.	D min.	Ø d h6	R	Klemmhalter Typ				Klemmhalter Typ toolholder type
									K10F	CN45F	AL41F	P07C	
R/L 610M1008-10	1.0	5.2	26	11	2.0	6.0	6.0	0.1			●		660... 676... ...6
R/L 610M1508-10	1.5	5.2	26	11	3.0	6.0	6.0	0.1			●		
R/L 610M2008-10	2.0	5.2	26	11	4.0	6.0	6.0	0.1			●		
R/L 610M2508-10	2.5	5.2	26	11	5.0	6.0	6.0	0.1			●		
R/L 610M3008-10	3.0	5.2	26	11	6.0	6.0	6.0	0.1			●		
R/L 610M1008-20	1.0	5.2	35	20	2.0	6.0	6.0	0.1			●		
R/L 610M1508-20	1.5	5.2	35	20	3.0	6.0	6.0	0.1			●		
R/L 610M2008-20	2.0	5.2	35	20	4.0	6.0	6.0	0.1			●		
R/L 610M2508-20	2.5	5.2	35	20	5.0	6.0	6.0	0.1			●		
R/L 610M3008-20	3.0	5.2	35	20	6.0	6.0	6.0	0.1			●		
R/L 610M1008-30	1.0	5.2	45	30	2.0	6.0	6.0	0.1			●		
R/L 610M1508-30	1.5	5.2	45	30	3.0	6.0	6.0	0.1			●		
R/L 610M2008-30	2.0	5.2	45	30	4.0	6.0	6.0	0.1			●		
R/L 610M2508-30	2.5	5.2	45	30	5.0	6.0	6.0	0.1			●		
R/L 610M3008-30	3.0	5.2	45	30	6.0	6.0	6.0	0.1			●		

Weitere HM Sorten können Sie in der Sortenübersicht im Kapitel "Technische Hinweise" und der Preisliste finden.

Bestellbeispiel:  
für rechte Ausführung und Sorte  
R610M1008-10/AL41F

More carbide grades you can find in the grades summary in the chapter "technical instructions" and in the price list.

order-example:  
righthand version and grade  
R610M1008-10/AL41F

## ULTRAMINI

Bohrungsbearbeitung  
ab  $\varnothing 0.2$  mm

grooving, boring and profiling  
starting at  $\varnothing 0.2$  mm

## Typ 610

Axialstechen  
mit Vollradius

face grooving  
with full radius

D min. 6.0 mm  
Stechtiefe t max. 6.0 mm  
Nutbreite bis 3.0 mm

D min. 6.0 mm  
depth of groove t max. 6.0 mm  
width of groove up to 3.0 mm

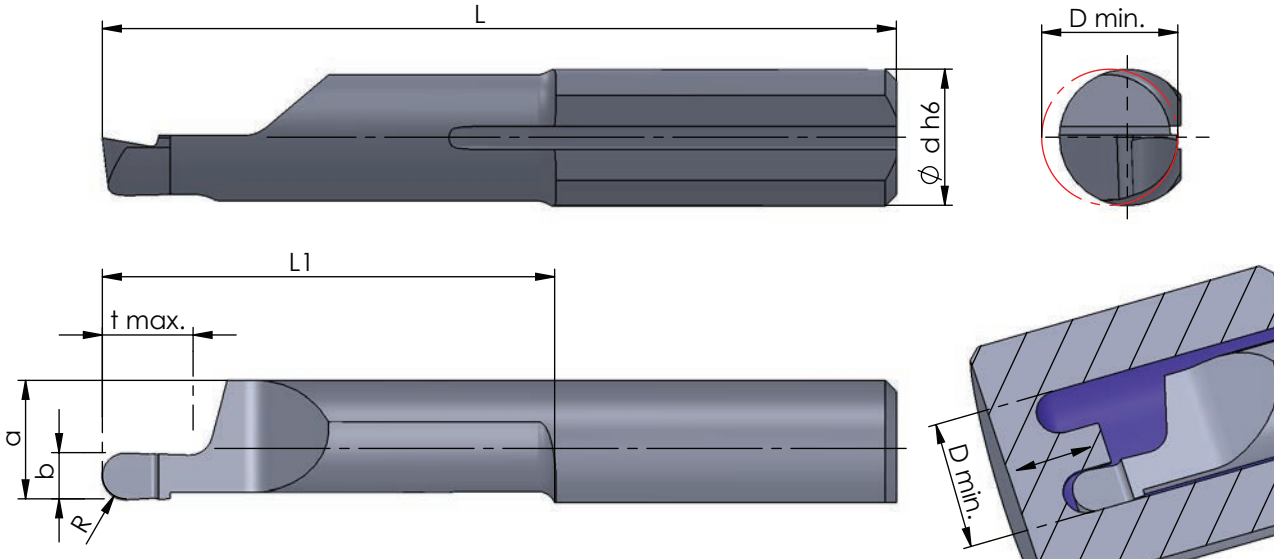

Rechts (R): wie gezeichnet  
Links (L): spiegelbildlich

righthand (R): as shown  
lefthand version (L): mirror image

Abmessungen in mm

dimensions in mm

Bestellnummer part number	b +0.05	R	a	L	L1	t max.	D min.	Ø d h6	K10F	CN45F	AL41F	P07C	Klemmhalter Typ	toolholder type
R/L 610.1005-10	1.0	0.50	5.2	26	11	2.0	6.0	6.0	●	●			660... 676... ...6	
R/L 610.1608-10	1.6	0.80	5.2	26	11	3.0	6.0	6.0		●				
R/L 610.2010-10	2.0	1.00	5.2	26	11	4.0	6.0	6.0		●				
R/L 610.2512-10	2.5	1.25	5.2	26	11	5.0	6.0	6.0	●	●				
R/L 610.3015-10	3.0	1.50	5.2	26	11	6.0	6.0	6.0	●	●				
R/L 610.1005-20	1.0	0.50	5.2	35	20	2.0	6.0	6.0	●	●				
R/L 610.1608-20	1.6	0.80	5.2	35	20	3.0	6.0	6.0		●				
R/L 610.2010-20	2.0	1.00	5.2	35	20	4.0	6.0	6.0	●	●				
R/L 610.2512-20	2.5	1.25	5.2	35	20	5.0	6.0	6.0		●				
R/L 610.3015-20	3.0	1.50	5.2	35	20	6.0	6.0	6.0	●	●				

Weitere HM Sorten können Sie in der Sortenübersicht im Kapitel "Technische Hinweise" und der Preisliste finden.

Bestellbeispiel:  
für rechte Ausführung und Sorte  
R610.1005-10/AL41F

More carbide grades you can find in the grades summary in the chapter "technical instructions" and in the price list.

order-example:  
righthand version and grade  
R610.1005-10/AL41F

**BROTECH**

# ULTRAMINI

Bohrungsbearbeitung  
ab  $\varnothing 0.2 \text{ mm}$

grooving, boring and profiling  
starting at  $\varnothing 0.2 \text{ mm}$

# Typ 620

Axialstechen  
am Zapfen vorbei

face grooving  
in pivots

D min. 6.0 mm  
Stechtiefe t max. 6.0 mm  
Nutbreite bis 3.0 mm

D min. 6.0 mm  
depth of groove t max. 6.0 mm  
width of groove up to 3.0 mm

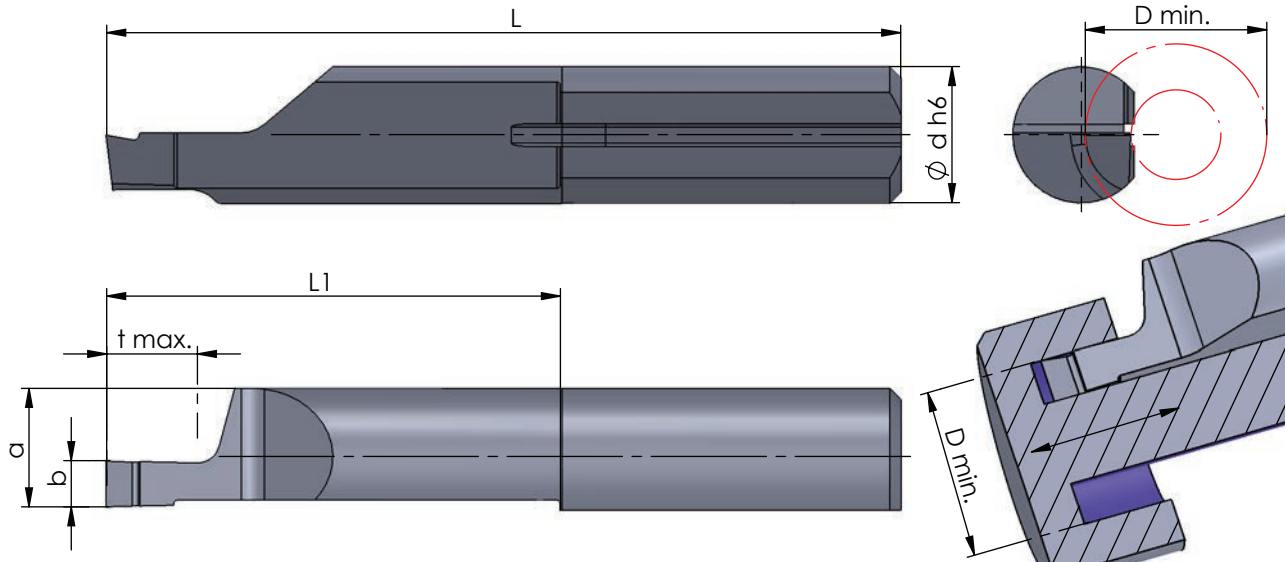

Rechts (R): wie gezeichnet  
Links (L): spiegelbildlich

righthand (R): as shown  
lefthand version (L): mirror image

Abmessungen in mm

dimensions in mm

Bestellnummer part number	b +0.05	a	L	L1	t max.	D min.	Ø d h6	Klemmhalter Typ				toolholder type
								K10F	CN45F	AL41F	PD2F	
R/L 620.1006-20	1.0	5.2	35	20	2.0	6.0	6.0	●	●	●		
R/L 620.1506-20	1.5	5.2	35	20	3.0	6.0	6.0	●	●	●		
R/L 620.2006-20	2.0	5.2	35	20	4.0	6.0	6.0	●	●	●		660... 676... ...6
R/L 620.2506-20	2.5	5.2	35	20	5.0	6.0	6.0		●	●		
R/L 620.3006-20	3.0	5.2	35	20	6.0	6.0	6.0		●	●		

Weitere HM Sorten können Sie in der Sortenübersicht im Kapitel "Technische Hinweise" und der Preisliste finden.

Bestellbeispiel:  
für rechte Ausführung und Sorte  
R620.1006-20/AL41F

More carbide grades you can find in the grades summary in the chapter "technical instructions" and in the price list.

order-example:  
righthand version and grade  
R620.1006-20/AL41F

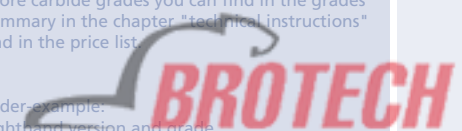

**ULTRAMINI**

Bohrungsbearbeitung  
ab  $\varnothing 0.2$  mm

grooving, boring and profiling  
starting at  $\varnothing 0.2$  mm

**Typ 620M**

Axialstechen  
am Zapfen vorbei,  
mit Eckenradius

face grooving  
in pivots,  
with corner radius

D min. 6.0 mm  
Stechtiefe t max. 6.0 mm  
Nutbreite bis 3.0 mm

D min. 6.0 mm  
depth of groove t max. 6.0 mm  
width of groove up to 3.0 mm

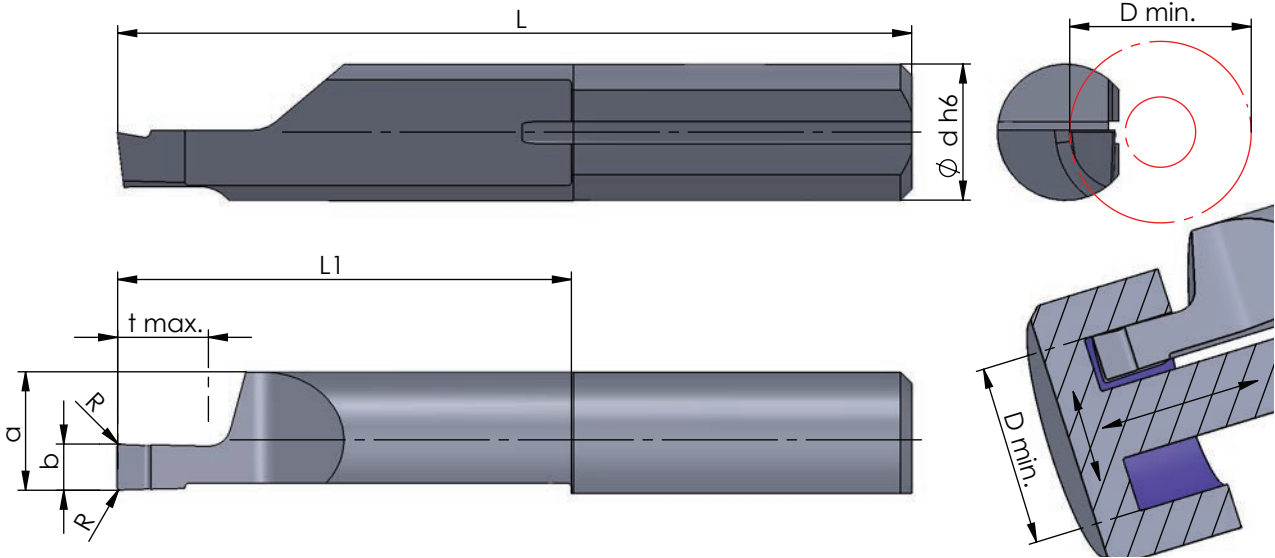

Rechts (R): wie gezeichnet  
Links (L): spiegelbildlich

righthand (R): as shown  
lefthand version (L): mirror image

Abmessungen in mm

dimensions in mm

Bestellnummer part number	b +0.05	a	L	L1	t max.	D min.	$\varnothing d h6$	R	K10F	CN45F	AL41F	PD2F	Klemmhalter Typ	toolholder type
R/L 620M1006-20	1.0	5.2	35	20	2.0	6.0	6.0	0.1						
R/L 620M1506-20	1.5	5.2	35	20	3.0	6.0	6.0	0.1						
R/L 620M2006-20	2.0	5.2	35	20	4.0	6.0	6.0	0.1						
R/L 620M2506-20	2.5	5.2	35	20	5.0	6.0	6.0	0.1						
R/L 620M3006-20	3.0	5.2	35	20	6.0	6.0	6.0	0.1						

Weitere HM Sorten können Sie in der Sortenübersicht im Kapitel "Technische Hinweise" und der Preisliste finden.

Bestellbeispiel:  
für rechte Ausführung und Sorte  
R620M1006-20/AL41F

More carbide grades you can find in the grades summary in the chapter "technical instructions" and in the price list.

order-example:  
righthand version and grade  
R620M1006-20/AL41F



# ULTRAMINI

Bohrungsbearbeitung  
ab  $\varnothing 0.2 \text{ mm}$

grooving, boring and profiling  
starting at  $\varnothing 0.2 \text{ mm}$

# Typ 010

Axialstechen

face grooving

D min. 6.0 mm  
Stechtiefe t max. 3.5 mm  
Nutbreite bis 3.0 mm

D min. 6.0 mm  
depth of groove t max. 3.5 mm  
width of groove up to 3.0 mm

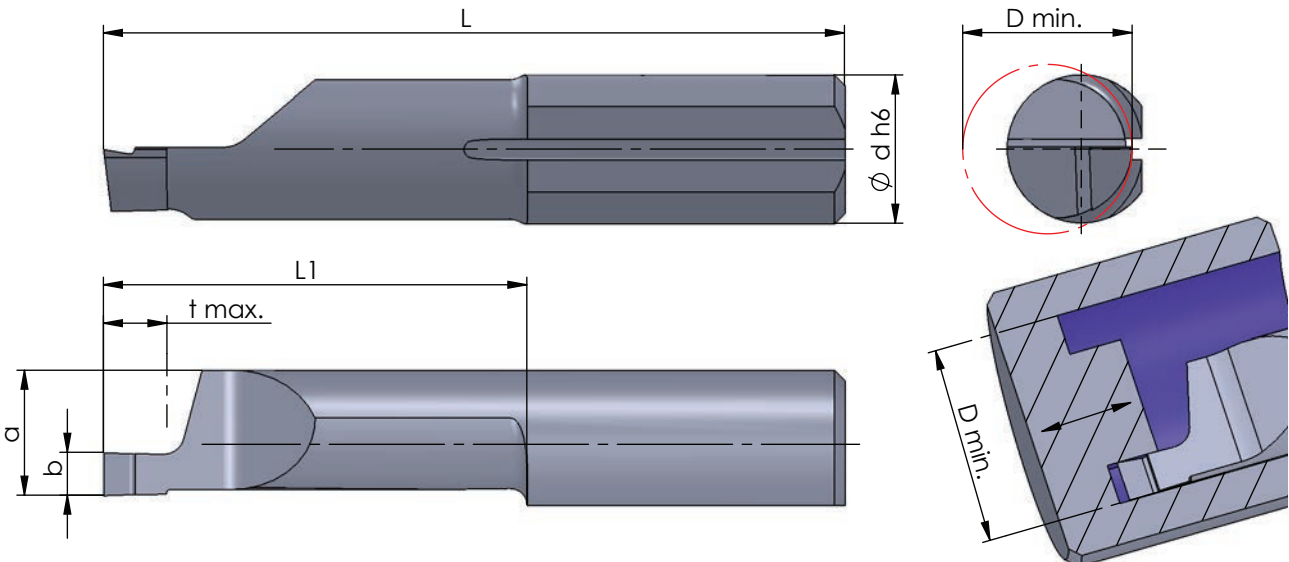

Rechts (R): wie gezeichnet  
Links (L): spiegelbildlich

righthand (R): as shown  
lefthand version (L): mirror image

Abmessungen in mm

dimensions in mm

Bestellnummer part number	b +0.05	a	L	L1	t max.	D min.	Ø d h6	Klemmhalter Typ				toolholder type
								K10F	CN45F	AL41F	P07C	
R/L 010.1006-10	1.0	5.2	26	11	1.5	6.0	6.0	●	●			660... ...6
R/L 010.1506-10	1.5	5.2	26	11	2.0	6.0	6.0	●	●			
R/L 010.1008-10	1.0	5.9	26	11	1.5	8.0	7.0	●	●			
R/L 010.1508-10	1.5	5.9	26	11	2.5	8.0	7.0	●	●			
R/L 010.2008-10	2.0	5.9	26	11	3.0	8.0	7.0	●	●			
R/L 010.2508-10	2.5	5.9	26	11	3.5	8.0	7.0	●	●			
R/L 010.3008-10	3.0	5.9	26	11	3.5	8.0	7.0	●	●			
R/L 010.1008-20	1.0	5.9	35	20	1.5	8.0	7.0	●	●		676...	670... 687... ...7
R/L 010.1508-20	1.5	5.9	35	20	2.5	8.0	7.0	●	●			
R/L 010.2008-20	2.0	5.9	35	20	3.0	8.0	7.0	●	●			
R/L 010.2508-20	2.5	5.9	35	20	3.5	8.0	7.0	●	●			
R/L 010.3008-20	3.0	5.9	35	20	3.5	8.0	7.0	●	●			
↳ ...												

Weitere HM Sorten können Sie in der Sortenübersicht im Kapitel "Technische Hinweise" und der Preisliste finden.

Bestellbeispiel:  
für rechte Ausführung und Sorte  
R010.1006-10/AL41F

More carbide grades you can find in the grades summary in the chapter "technical instructions" and in the price list.

order-example:  
righthand version and grade  
R010.1006-10/AL41F



**ULTRAMINI**

Bohrungsbearbeitung  
ab  $\varnothing$  0.2 mm

grooving, boring and profiling  
starting at  $\varnothing$  0.2 mm

**Typ 010**

Axialstechen

face grooving

D min. 6.0 mm  
Stechtiefe t max. 3.5 mm  
Nutbreite bis 3.0 mm

D min. 6.0 mm  
depth of groove t max. 3.5 mm  
width of groove up to 3.0 mm

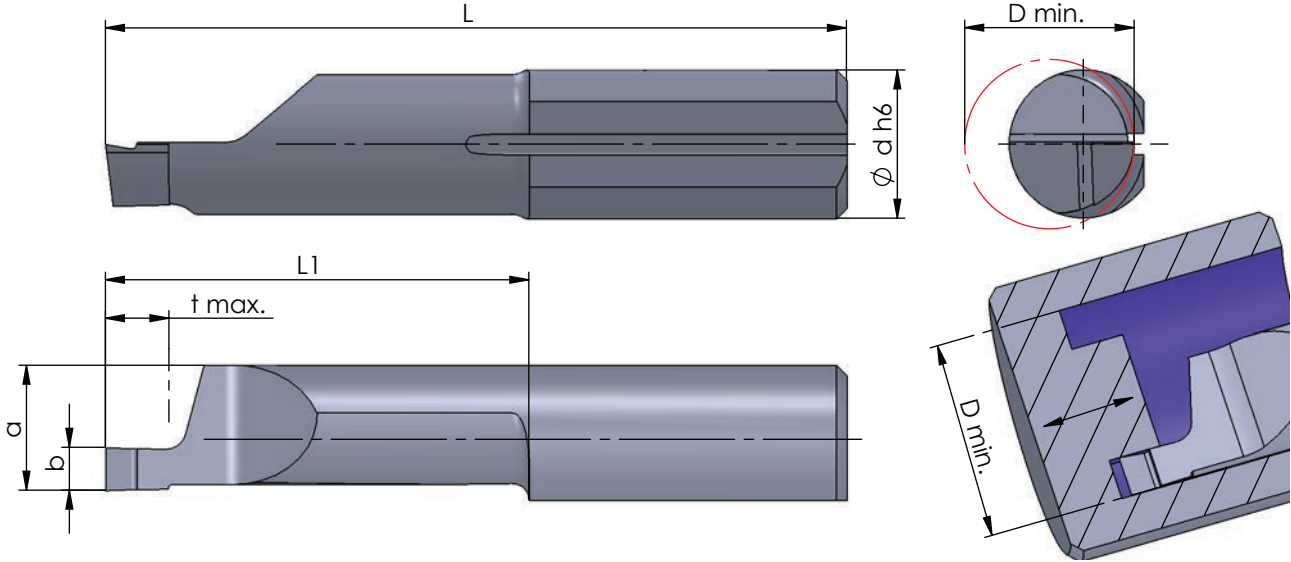

Rechts (R): wie gezeichnet  
Links (L): spiegelbildlich

righthand (R): as shown  
lefthand version (L): mirror image

Abmessungen in mm

dimensions in mm

Bestellnummer part number	b +0.05	a	L	L1	t max.	D min.	Ø d h6	Klemmhalter Typ				toolholder type
								K10F	CN45F	AL41F	P07C	
...												
R/L 010.1008-30	1.0	5.9	45	30	1.5	8.0	7.0	●	●			
R/L 010.1508-30	1.5	5.9	45	30	2.5	8.0	7.0	●	●			
R/L 010.2008-30	2.0	5.9	45	30	3.0	8.0	7.0	●	●			
R/L 010.2508-30	2.5	5.9	45	30	3.5	8.0	7.0	●	●			
R/L 010.3008-30	3.0	5.9	45	30	3.5	8.0	7.0	●	●			

Weitere HM Sorten können Sie in der Sortenübersicht im Kapitel "Technische Hinweise" und der Preisliste finden.

Bestellbeispiel:  
für rechte Ausführung und Sorte  
R010.1008-30/AL41F

More carbide grades you can find in the grades summary in the chapter "technical instructions" and in the price list.

order-example:  
righthand version and grade  
R010.1008-30/AL41F



# ULTRAMINI

Bohrungsbearbeitung  
ab  $\varnothing 0.2$  mm

grooving, boring and profiling  
starting at  $\varnothing 0.2$  mm

# Typ 010M

Axialstechen  
mit Eckenradius

face grooving  
with corner radius

D min. 8.0 mm  
Stechtiefe t max. 6.0 mm  
Nutbreite bis 3.0 mm

D min. 8.0 mm  
depth of groove t max. 6.0 mm  
width of groove up to 3.0 mm

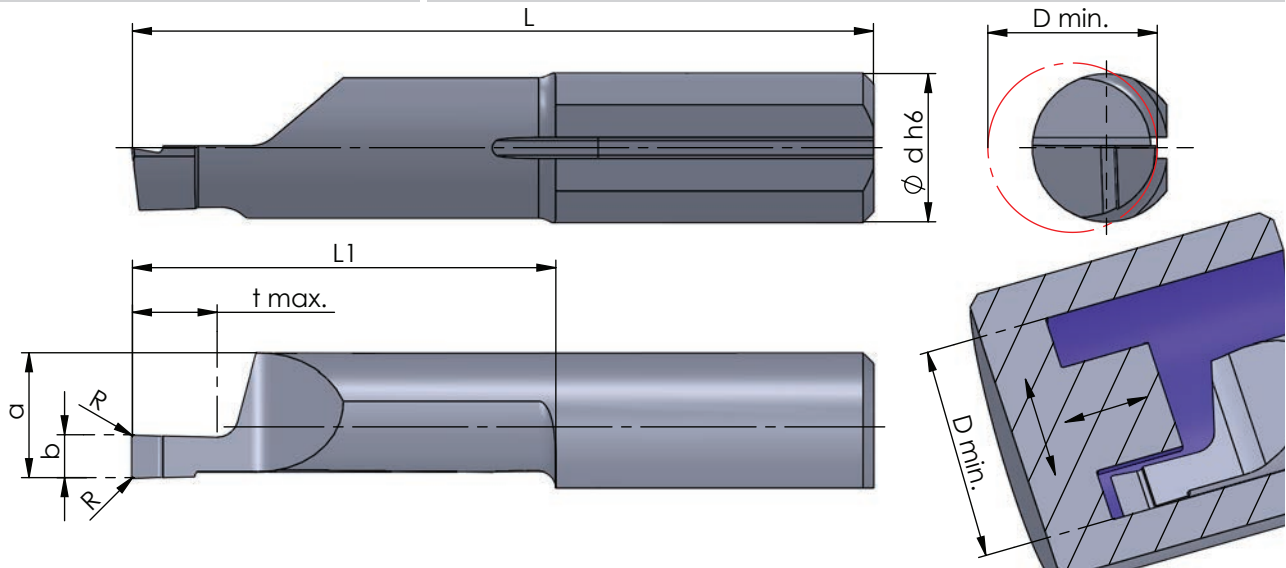

Rechts (R): wie gezeichnet  
Links (L): spiegelbildlich

righthand (R): as shown  
lefthand version (L): mirror image

Abmessungen in mm

dimensions in mm

Bestellnummer part number	b +0.05	b (inch)	a	L	L1	t max.	D min.	Ø d h6	R	Klemmhalter Typ toolholder type				
										K10F	CN45F	AL41F	P07C	
R/L 010M1008-10	1.0		5.9	26	11	2.0	8.0	7.0	0.1					670... 676... 687... ...7
R/L 010M1508-10	1.5		5.9	26	11	3.0	8.0	7.0	0.1					
R/L 010M1578-10	1.57	0.062"	5.9	26	11	3.0	8.0	7.0	0.1					
R/L 010M2008-10	2.0		5.9	26	11	4.0	8.0	7.0	0.1					
R/L 010M2508-10	2.5		5.9	26	11	5.0	8.0	7.0	0.1					
R/L 010M3008-10	3.0		5.9	26	11	6.0	8.0	7.0	0.1					
R/L 010M1008-20	1.0		5.9	35	20	2.0	8.0	7.0	0.1					
R/L 010M1508-20	1.5		5.9	35	20	3.0	8.0	7.0	0.1					
R/L 010M2008-20	2.0		5.9	35	20	4.0	8.0	7.0	0.1					
R/L 010M2308-20	2.38	0.094"	5.9	35	20	5.0	8.0	7.0	0.1					
R/L 010M2508-20	2.5		5.9	35	20	5.0	8.0	7.0	0.1					
R/L 010M3008-20	3.0		5.9	35	20	6.0	8.0	7.0	0.1					

↳ ...

Weitere HM Sorten können Sie in der Sortenübersicht im Kapitel "Technische Hinweise" und der Preisliste finden.

Bestellbeispiel:  
für rechte Ausführung und Sorte  
R010M1008-10/AL41F

More carbide grades you can find in the grades summary in the chapter "technical instructions" and in the price list.

order-example:  
righthand version and grade  
R010M1008-10/AL41F





**ULTRAMINI**

Bohrungsbearbeitung  
ab  $\varnothing 0.2$  mm

grooving, boring and profiling  
starting at  $\varnothing 0.2$  mm

**Typ 010M**

Axialstechen  
mit Eckenradius

face grooving  
with corner radius

D min. 8.0 mm  
Stechtiefe t max. 6.0 mm  
Nutbreite bis 3.0 mm

D min. 8.0 mm  
depth of groove t max. 6.0 mm  
width of groove up to 3.0 mm

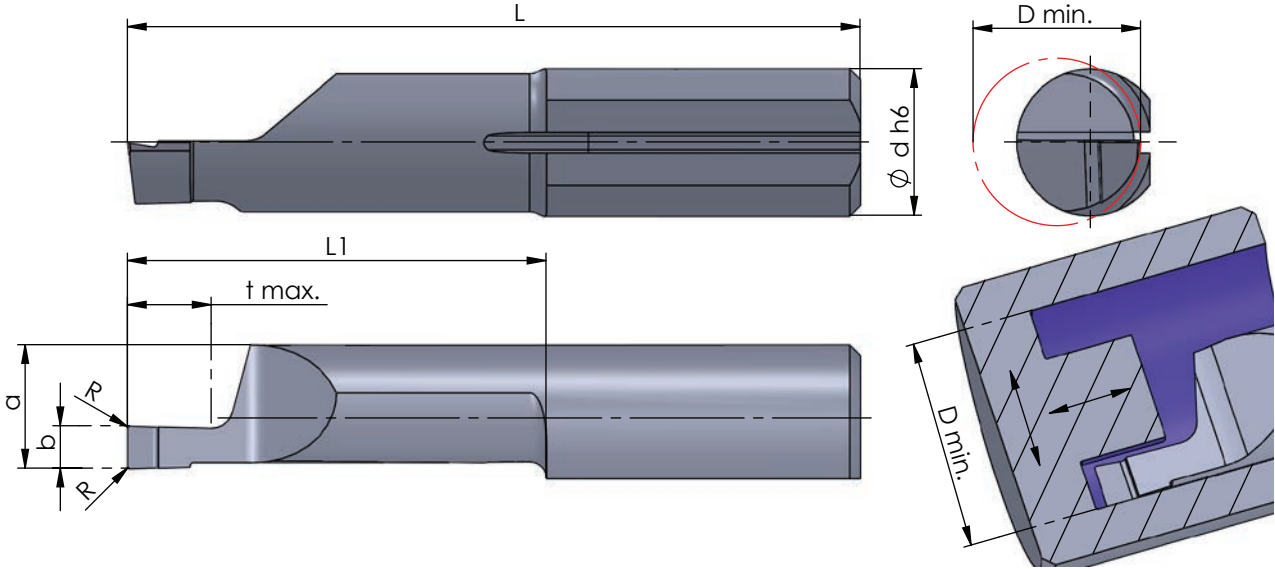

Rechts (R): wie gezeichnet  
Links (L): spiegelbildlich

righthand (R): as shown  
lefthand version (L): mirror image

Abmessungen in mm

dimensions in mm

Bestellnummer part number	b +0.05	b (inch)	a	L	L1	t max.	D min.	$\varnothing$ d h6	R	Klemmhalter Typ toolholder type					
										K10F	CN45F	AL41F	P07C		
...															
R/L 010M1008-30	1.0		5.9	45	30	2.0	8.0	7.0	0.1			●			
R/L 010M1508-30	1.5		5.9	45	30	3.0	8.0	7.0	0.1			●			
R/L 010M2008-30	2.0		5.9	45	30	4.0	8.0	7.0	0.1			●			670, ... 676, ... 687, ... ..., 7
R/L 010M2508-30	2.5		5.9	45	30	5.0	8.0	7.0	0.1			●			
R/L 010M3008-30	3.0		5.9	45	30	6.0	8.0	7.0	0.1			●			

Weitere HM Sorten können Sie in der Sortenübersicht im Kapitel "Technische Hinweise" und der Preisliste finden.

Bestellbeispiel:  
für rechte Ausführung und Sorte  
R010M1008-30/AL41F

More carbide grades you can find in the grades summary in the chapter "technical instructions" and in the price list.

order-example:  
righthand version and grade  
R010M1008-30/AL41F



# ULTRAMINI

Bohrungsbearbeitung  
ab  $\varnothing$  0.2 mm

grooving, boring and profiling  
starting at  $\varnothing$  0.2 mm

# Typ 010

Axialstechen  
mit Vollradius

face grooving  
with full radius

D min. 8.0 mm  
Stechtiefe t max. 6.0 mm  
Nutbreite bis 3.0 mm

D min. 8.0 mm  
depth of groove t max. 6.0 mm  
width of groove up to 3.0 mm

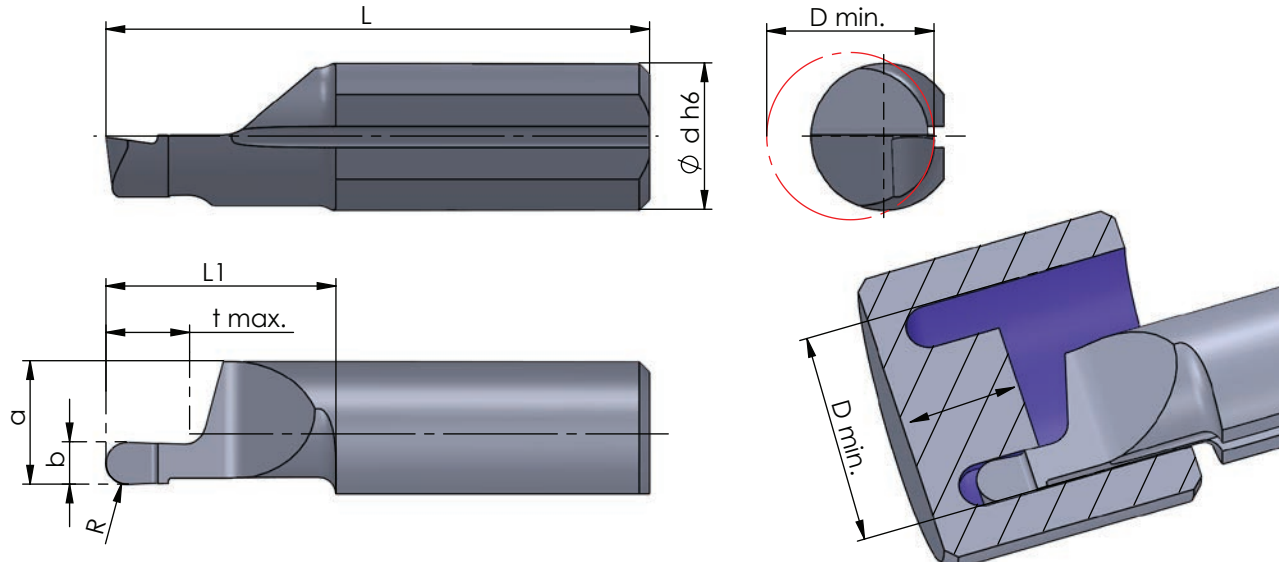

Rechts (R): wie gezeichnet  
Links (L): spiegelbildlich

righthand (R): as shown  
lefthand version (L): mirror image

Abmessungen in mm

dimensions in mm

Bestellnummer part number	b +0.05	b (inch)	R	a	L	L1	t max.	D min.	$\varnothing$ d h6	Klemmhalter Typ toolholder type				
										K10F	CN45F	AL41F	PD2F	
R/L 010.1005-10	1.0		0.5	5.9	26	11	2.0	8.0	7.0			●	●	670... 676... 687... ...7
R/L 010.1507-10	1.57	0.062"	0.78	5.9	26	11	3.0	8.0	7.0			●		
R/L 010.1608-10	1.6		0.8	5.9	26	11	3.0	8.0	7.0			●	●	
R/L 010.1910-10	1.98	0.078"	0.99	5.9	26	11	4.0	8.0	7.0			●		
R/L 010.2010-10	2.0		1.0	5.9	26	11	4.0	8.0	7.0			●	●	
R/L 010.2512-10	2.5		1.25	5.9	26	11	5.0	8.0	7.0			●		
R/L 010.3015-10	3.0		1.5	5.9	26	11	6.0	8.0	7.0			●	●	
R/L 010.1005-20	1.0		0.5	5.9	35	20	2.0	8.0	7.0			●	●	
R/L 010.1608-20	1.6		0.8	5.9	35	20	3.0	8.0	7.0			●		
R/L 010.2010-20	2.0		1.0	5.9	35	20	4.0	8.0	7.0			●	●	
R/L 010.2512-20	2.5		1.25	5.9	35	20	5.0	8.0	7.0			●	●	
R/L 010.3015-20	3.0		1.5	5.9	35	20	6.0	8.0	7.0			●	●	

Weitere HM Sorten können Sie in der Sortenübersicht im Kapitel "Technische Hinweise" und der Preisliste finden.

Bestellbeispiel:  
für rechte Ausführung und Sorte  
R010.1005-10/AL41F

More carbide grades you can find in the grades summary in the chapter "technical instructions" and in the price list.

order-example:  
righthand version and grade  
R010.1005-10/AL41F

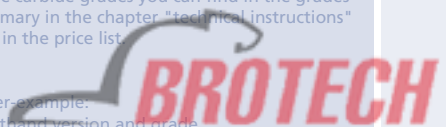

**ULTRAMINI**

Bohrungsbearbeitung  
ab  $\varnothing$  0.2 mm

grooving, boring and profiling  
starting at  $\varnothing$  0.2 mm

**Typ 015**

Axialstechen

face grooving

D min. 8.0 mm  
Stechtiefe t max. 30 mm  
Nutbreite bis 3.0 mm

D min. 8.0 mm  
depth of groove t max. 30 mm  
width of groove up to 3.0 mm

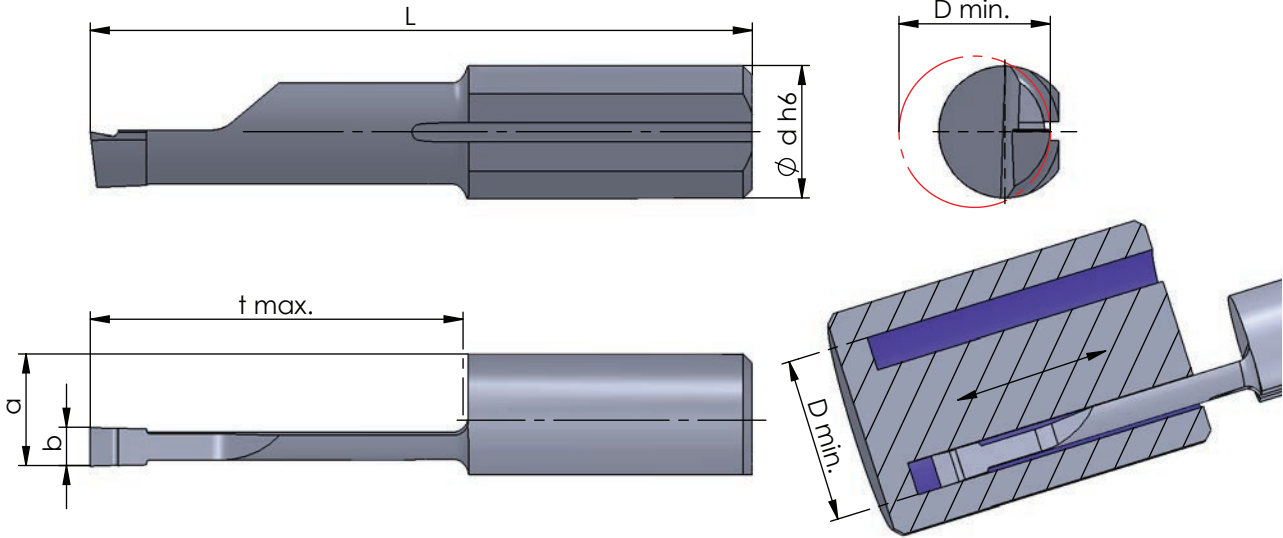

Rechts (R): wie gezeichnet  
Links (L): spiegelbildlich

righthand (R): as shown  
lefthand version (L): mirror image

Abmessungen in mm

dimensions in mm

Bestellnummer part number	b +0.05	a	L	t max.	D min.	Ø d h6	Klemmhalter Typ				toolholder type
							K10F	CN45F	AL41F	PD2F	
R/L 015.1515-10	1.5	5.9	26	10	8.0	7.0	●	●	●		
R/L 015.2015-15	2.0	5.9	30	15	8.0	7.0		●	●		
R/L 015.2015-20	2.0	5.9	35	20	8.0	7.0	●	●	●		
R/L 015.2515-20	2.5	5.9	35	20	8.0	7.0		●	●		670... 676... 687... ...7
R/L 015.3015-20	3.0	5.9	35	20	8.0	7.0	●	●	●		
R/L 015.3015-30	3.0	5.9	45	30	8.0	7.0		●	●		

Weitere HM Sorten können Sie in der Sortenübersicht im Kapitel "Technische Hinweise" und der Preisliste finden.

Bestellbeispiel:  
für rechte Ausführung und Sorte  
R015.1515-10/AL41F

More carbide grades you can find in the grades summary in the chapter "technical instructions" and in the price list.

order-example:  
righthand version and grade  
R015.1515-10/AL41F



# ULTRAMINI

Bohrungsbearbeitung  
ab  $\varnothing 0.2 \text{ mm}$

grooving, boring and profiling  
starting at  $\varnothing 0.2 \text{ mm}$

# Typ 015M

Axialstechen  
mit Eckenradius

face grooving  
with corner radius

D min. 8.0 mm  
Stechtiefe t max. 30 mm  
Nutbreite bis 3.0 mm

D min. 8.0 mm  
depth of groove t max. 30 mm  
width of groove up to 3.0 mm

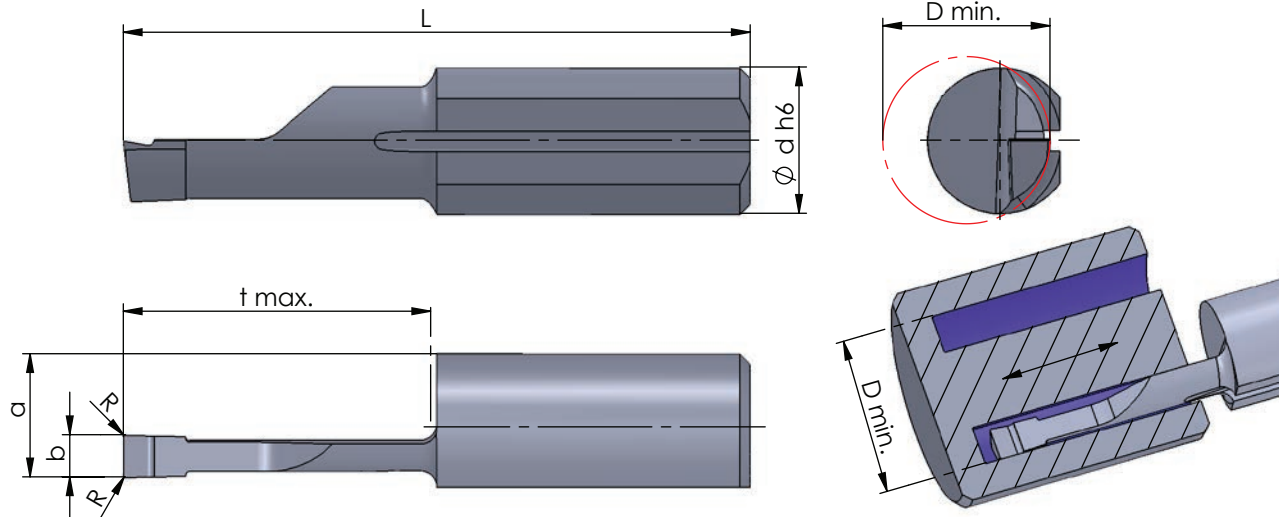

Rechts (R): wie gezeichnet  
Links (L): spiegelbildlich

righthand (R): as shown  
lefthand version (L): mirror image

Abmessungen in mm

dimensions in mm

Bestellnummer part number	b +0.05	a	L	t max.	D min.	$\varnothing d h6$	R	Klemmhalter Typ				toolholder type
								K10F	CN45F	AL41F	PD2F	
R/L 015M1515-10	1.5	5.9	26	10	8.0	7.0	0.1					
R/L 015M2015-15	2.0	5.9	30	15	8.0	7.0	0.1					
R/L 015M2015-20	2.0	5.9	35	20	8.0	7.0	0.1					
R/L 015M2515-20	2.5	5.9	35	20	8.0	7.0	0.1					670... 676... 687... ...7
R/L 015M3015-20	3.0	5.9	35	20	8.0	7.0	0.1					
R/L 015M3015-30	3.0	5.9	45	30	8.0	7.0	0.1					

Weitere HM Sorten können Sie in der Sortenübersicht im Kapitel "Technische Hinweise" und der Preisliste finden.

Bestellbeispiel:  
für rechte Ausführung und Sorte  
R015M1515-10/AL41F

More carbide grades you can find in the grades summary in the chapter "technical instructions" and in the price list.

order-example:  
righthand version and grade  
R015M1515-10/AL41F



## ULTRAMINI

Bohrungsbearbeitung  
ab  $\varnothing 0.2$  mm

grooving, boring and profiling  
starting at  $\varnothing 0.2$  mm

## Typ 012 / 016

Axialstechen  
mit Eckenradius  
und doppeltem Kühlkanal

face grooving  
with corner radius  
and double internal cooling

D min. 12 mm  
Stechtiefe t max. 20 mm  
Nutbreite bis 4.0 mm

D min. 12 mm  
depth of groove t max. 20 mm  
width of groove up to 4.0 mm

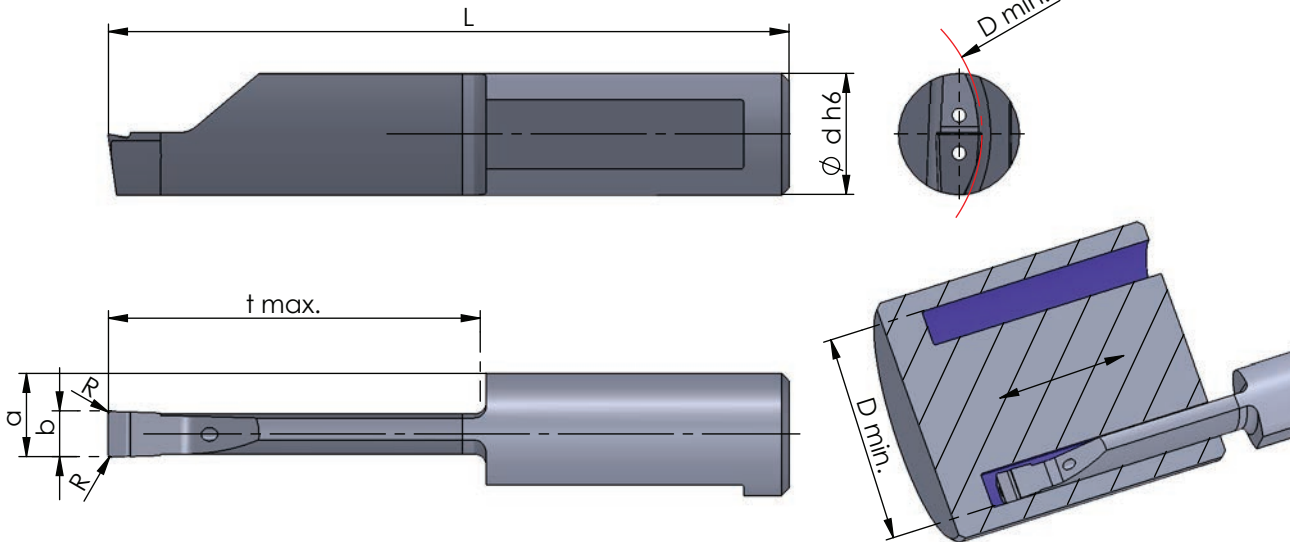

Rechts (R): wie gezeichnet  
Links (L): spiegelbildlich

Kühlmitteldruckempfehlung  
70 bar

Abmessungen in mm

righthand (R): as shown  
lefthand version (L): mirror image

Coolant pressure recommendation  
70 bar

dimensions in mm

Bestellnummer part number	b +0.05	a	L	t max.	D min.	Ø d h6	R	Klemmhalter Typ				toolholder type
								K10F	CN45F	AL41F	PD2F	
R/L 012.0200-10	2.0	5.00	30	10	12	8.0	0.2			●		680... 681... 687... ...8
R/L 012.0200-15	2.0	5.00	35	15	12	8.0	0.2			●		
R/L 012.0250-10	2.5	5.25	30	10	12	8.0	0.2			●		
R/L 012.0250-20	2.5	5.25	40	20	12	8.0	0.2			●		
R/L 016.0300-10	3.0	5.50	30	10	16	8.0	0.2		●	●		
R/L 016.0300-20	3.0	5.50	40	20	16	8.0	0.2		●	●		
R/L 016.0400-10	4.0	6.00	30	10	16	8.0	0.2		●	●		
R/L 016.0400-20	4.0	6.00	40	20	16	8.0	0.2		●	●		

Weitere HM Sorten können Sie in der Sortenübersicht im Kapitel "Technische Hinweise" und der Preisliste finden.

Bestellbeispiel:  
für rechte Ausführung und Sorte  
R012.0200-10/AL41F

More carbide grades you can find in the grades summary in the chapter "technical instructions" and in the price list.

order-example:  
righthand version and grade  
R012.0200-10/AL41F

# ULTRAMINI

Bohrungsbearbeitung  
ab  $\varnothing 0.2$  mm

grooving, boring and profiling  
starting at  $\varnothing 0.2$  mm

# Typ 020

Axialstechen  
mit Eckenradius  
und doppeltem Kühlkanal

face grooving  
with corner radius  
and double internal cooling

D min. 20 mm  
Stechtiefe t max. 40 mm  
Nutbreite bis 5.0 mm

D min. 20 mm  
depth of groove t max. 40 mm  
width of groove up to 5.0 mm

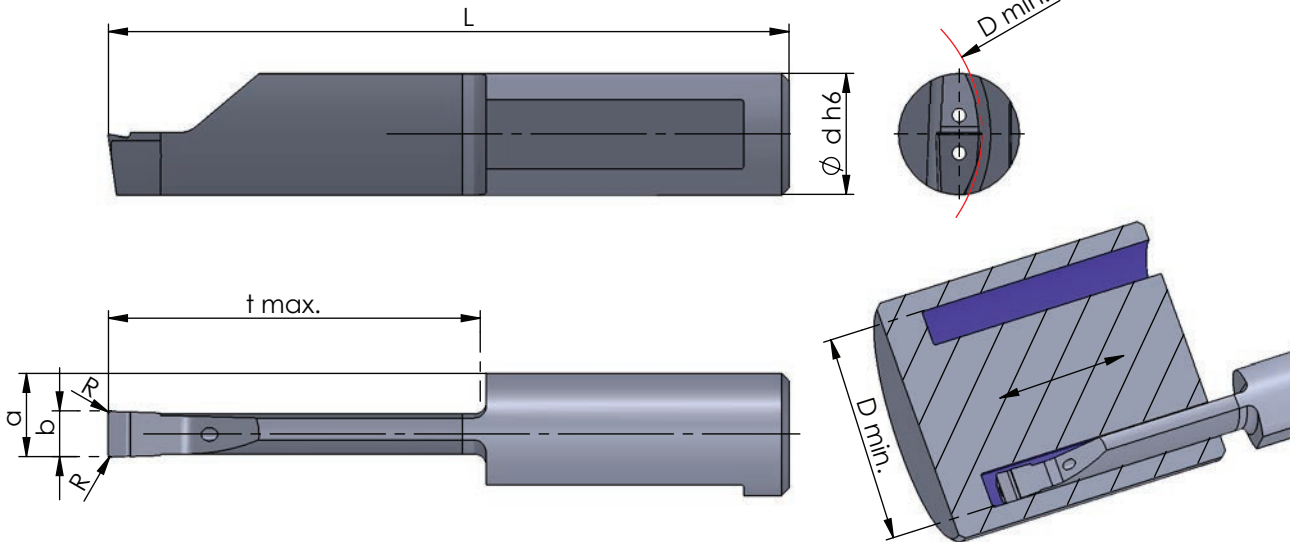

Rechts (R): wie gezeichnet  
Links (L): spiegelbildlich

Kühlmitteldruckempfehlung  
70 bar

Abmessungen in mm

righthand (R): as shown  
lefthand version (L): mirror image

Coolant pressure recommendation  
70 bar

dimensions in mm

Bestellnummer part number	b +0.05	a	L	t max.	D min.	$\varnothing d h6$	R					Klemmhalter Typ toolholder type
								K10F	CN45F	AL41F	PD2F	
R/L 020.0300-25	3.0	5.5	45	25	20	8.0	0.2			●	●	680... 681... 687... ...8
R/L 020.0300-30	3.0	5.5	50	30	20	8.0	0.2			●	●	
R/L 020.0300-35	3.0	5.5	55	35	20	8.0	0.2			●	●	
R/L 020.0300-40	3.0	5.5	60	40	20	8.0	0.2			●	●	
R/L 020.0400-25	4.0	6.0	45	25	20	8.0	0.2			●	●	
R/L 020.0400-30	4.0	6.0	50	30	20	8.0	0.2			●	●	
R/L 020.0400-35	4.0	6.0	55	35	20	8.0	0.2			●	●	
R/L 020.0400-40	4.0	6.0	60	40	20	8.0	0.2			●	●	
R/L 020.0500-20	5.0	6.5	40	20	20	8.0	0.2			●	●	
R/L 020.0500-25	5.0	6.5	45	25	20	8.0	0.2			●	●	
R/L 020.0500-30	5.0	6.5	50	30	20	8.0	0.2			●	●	
R/L 020.0500-35	5.0	6.5	55	35	20	8.0	0.2			●	●	
R/L 020.0500-40	5.0	6.5	60	40	20	8.0	0.2			●	●	

Weitere HM Sorten können Sie in der Sortenübersicht im Kapitel "Technische Hinweise" und der Preisliste finden.

Bestellbeispiel:  
für rechte Ausführung und Sorte  
R020.0300-25/AL41F

More carbide grades you can find in the grades summary in the chapter "technical instructions" and in the price list.

order-example:  
righthand version and grade  
R020.0300-25/AL41F



**ULTRAMINI**

Bohrungsbearbeitung  
ab  $\varnothing$  0.2 mm

grooving, boring and profiling  
starting at  $\varnothing$  0.2 mm

**Typ 520**

Fasen

D min. 1.0 mm  
Stechtiefe t max. 4.0 mm

chamfering

D min. 1.0 mm  
depth of groove t max. 4.0 mm

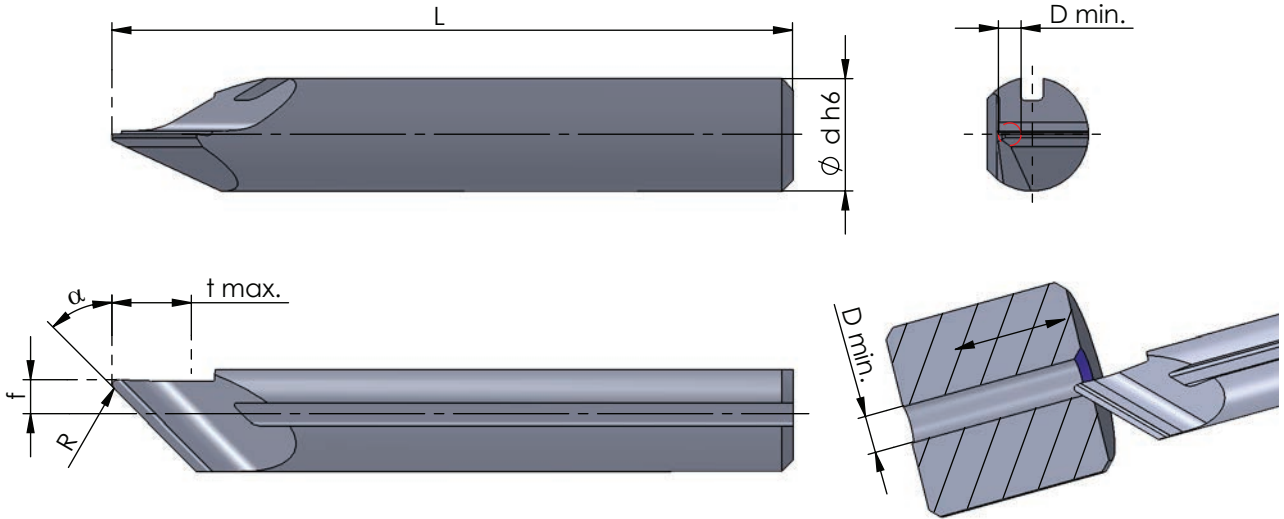

Rechts (R): wie gezeichnet  
Links (L): spiegelbildlich

righthand (R): as shown  
lefthand version (L): mirror image

Abmessungen in mm

dimensions in mm

Bestellnummer part number	$\alpha$	f	L	t max.	D min.	$\varnothing$ d h6	R	Klemmhalter Typ				toolholder type
								K10F	CN45F	AL41F	PD2F	
R/L 520.0045-15	45°	1.5	30	3.5	1.0	5.0	0.2		●			645... 650... ...5
R/L 520.0060-15	60°	1.5	30	4.0	1.0	5.0	0.2	●	●			

Weitere HM Sorten können Sie in der Sortenübersicht im Kapitel "Technische Hinweise" und der Preisliste finden.

Bestellbeispiel:  
für rechte Ausführung und Sorte  
R520.0045-15/AL41F

More carbide grades you can find in the grades summary in the chapter "technical instructions" and in the price list.

order-example:  
righthand version and grade  
R520.0045-15/AL41F

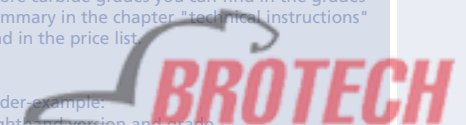

# ULTRAMINI

Bohrungsbearbeitung  
ab Ø 0.2 mm

grooving, boring and profiling  
starting at Ø 0.2 mm

# Sets



Bestellnummer part number	Inhalt Content	K10F AL41F P18C CN45F
<p><b>SET.1</b></p> <ul style="list-style-type: none"> <li>• Ausdrehen und Kopieren (Rechte Ausführung)</li> <li>• Ausdrehen und Fasen (Rechte Ausführung)</li> <li>• Stechdrehen (Rechte Ausführung)</li> <li>• boring and profiling (righthand version)</li> <li>• boring and chamfering (righthand version)</li> <li>• grooving (righthand version)</li> </ul>	<p><b>Halter / toolholder:</b></p> <p>1 x 676.0016-D</p> <p>1 x 645.0016-D</p> <p><b>Schneideinsatz / insert:</b></p> <p>1 x R050.6-22</p> <p>1 x R050.5-20</p> <p>1 x R060.5-20</p> <p>1 x R050.4-16</p> <p>1 x R050.3-16</p> <p>1 x R006.0200-22</p> <p>1 x R006.0150-22</p> <p>1 x R005.0200-20</p> <p>1 x R005.0150-20</p> <p>1 x R004.0100-16</p>	<p>•</p> <p>•</p> <p>•</p> <p>•</p> <p>•</p> <p>•</p> <p>•</p> <p>•</p> <p>•</p> <p>•</p>

Bestellnummer part number	Inhalt Content	K10F AL41F P18C CN45F
<p><b>SET.2</b></p> <ul style="list-style-type: none"> <li>• Stechdrehen (Rechte Ausführung)</li> <li>• grooving (righthand version)</li> </ul>	<p><b>Halter / toolholder:</b></p> <p>1 x 676.0016-D</p> <p>1 x 645.0016-D</p> <p><b>Schneideinsatz / insert:</b></p> <p>1 x R006.0200-22</p> <p>1 x R006.0150-22</p> <p>1 x R005.0200-20</p> <p>1 x R005.0150-20</p> <p>1 x R004.0100-16</p>	<p>•</p> <p>•</p> <p>•</p> <p>•</p> <p>•</p>

Weitere Ausführungen auf Anfrage oder in der Preisliste.

Bestellbeispiel:  
SET.1

More versions on request and in the price list.





**ULTRAMINI**

Bohrungsbearbeitung  
ab Ø 0.2 mm

grooving, boring and profiling  
starting at Ø 0.2 mm

**Sets**



Bestellnummer  
part number

Inhalt  
Content

K10F  
AL41F  
P18C  
CN45F

SET.3



• Ausdrehen und Kopieren  
(Rechte Ausführung)

• boring and profiling  
(righthand version)

**Halter / toolholder:**

1 x 676.0016-D  
1 x 645.0016-D

**Schneideinsatz / insert:**

1 x R050.6-22  
1 x R050.5-20  
1 x R050.4-16  
1 x R050.3-16

•  
•  
•  
•

Bestellnummer  
part number

Inhalt  
Content

K10F  
AL41F  
P18C  
CN45F

SET.6R



• Axialstechen  
(Rechte Ausführung)

• face grooving  
(righthand version)

**Halter / toolholder:**

1 x 676.0016-D

**Schneideinsatz / insert:**

1 x R010.2508-20  
1 x R010.2008-10  
1 x R010.1508-10  
1 x R010.3008-20  
1 x R010.1008-10

•  
•  
•  
•  
•

Weitere Ausführungen auf Anfrage oder in der  
Preisliste.

More versions on request and in the price list.

Bestellbeispiel:  
SET.3

order example:  
SET.3



## ULTRAMINI

Bohrungsbearbeitung  
ab  $\varnothing$  0.2 mm

grooving, boring and profiling  
starting at  $\varnothing$  0.2 mm

## Technische Hinweise

Grundsätzliche Informationen zum  
Werkzeugprogramm Ultramini

Technical instructions  
Basic informations about the tool pro-  
gram Ultramini

### Spitzenhöhe Ultramini:

Die Plattensitze der Ultramini-Werkzeuge garantieren eine exakte Position auf Spitzenhöhe. Trotzdem ist immer auf die Spitzenhöhe zu achten, denn Abweichungen können besonders bei der Bearbeitung kleinster Durchmesser Probleme bereiten.

#### Centre height Ultramini:

The seatings of the Ultramini tools guarantee a accurate centre height of these tools. In spite of this please have always a look at your tools because a difference may cause problems, especially when machining small diameters.



### Späneabfuhr Ultramini:

Bitte wählen Sie schmale Schneidbreiten, damit der Span geschmeidig bleibt und am Werkzeug vorbei aus der Bohrung fließen kann. Um einen Spänestau zu vermeiden ist stufenförmig oder mit Schnittunterbrechung zu stechen.

#### Removal of chips Ultramini:

Please choose inserts with small cutting width, so the chips keep smoothly and will be able to flow out of the bore beside the tool. To avoid jam of chips use the technique to groove by steps.

### Kühlmittel Ultramini:

Verwenden Sie gefiltertes Kühlmittel um die Späne auszuspülen und die Schneide zu kühlen. Ein Kühlmitteldruck von mindestens 5 bar wird empfohlen.

#### Coolant Ultramini:

Use filtered coolant for transporting the chips out and for cooling the insert itself. A coolant pressure of 5 bar minimum is recommended.

## ULTRAMINI

Bohrungsbearbeitung  
ab Ø 0.2 mm

grooving, boring and profiling  
starting at Ø 0.2 mm

## Technische Hinweise

Allgemeine Informationen zum  
Gewindeschneiden

Technical instructions  
General informations about threading



## Empfohlene Anzahl der Schnitte

Die Anzahl der Schnitte ist nur ein Richtwert für das Gewindedrehen. Um eine möglichst lange Standzeit der Schneide zu erreichen beachten Sie bitte die Erklärungen für die Zustellung.

Leerschnitte zum Fertigschneiden sind in dieser Tabelle nicht berücksichtigt.

### Recommended number of passes

The number of passes is only a recommendation for threading. To reach a good tool life you have to mention the explanation for the infeed.

Finishing passes are not considered in that chart.

	Stahl (Festigkeit N/mm <sup>2</sup> ) Steel (N/mm <sup>2</sup> tensile strength)					rostfreier Stahl stainless steel	Guss cast iron	Aluminium aluminium	
	400-500	500-700	700-850	850-1150	>1150				
<b>V m/min</b>	<b>160</b>	<b>140</b>	<b>120</b>	<b>90</b>	<b>70</b>	<b>90</b>	<b>100</b>	<b>300</b>	
Steigung P Pitch P		Anzahl der Schnitte number of passes							
mm	Gg/" TPI								
0,5	48	5	5	5	5	8	8	5	5
0,8	32	6	6	6	6	8	8	6	6
1	24	7	7	7	7	8	8	7	7
1,25	20-19	8	8	8	8	10	10	8	8
1,5	16	10	10	10	10	12	12	10	10
1,75	14	12	12	12	12	14	14	12	12
2	12-11	13	13	13	13	15	15	13	13
2,5	10	15	15	16	16	18	18	16	15
3 - 3,5	8	16	16	17	17	20	20	17	16
4		18	18	19	19	22	22	19	18
5		20	20	21	21	24	24	21	20
6		22	22	23	23	26	26	23	22

## ULTRAMINI

Bohrungsbearbeitung  
ab Ø 0.2 mm

grooving, boring and profiling  
starting at Ø 0.2 mm

## Technische Hinweise

Allgemeine Informationen zum  
Gewindeschneiden

Technical instructions  
General informations about threading

## Vorschubrichtung

Mit jedem Schneideinsatz für das Gewindedrehen kann sowohl ein Rechts- wie auch ein Linksgewinde geschnitten werden. Hierbei ist folgende Vorschubrichtung zu beachten:

### Feed direction

Every insert can be used for right- and lefthand thread. You only have to consider the following feed direction:

Rechtsgewinde  
thread right hand

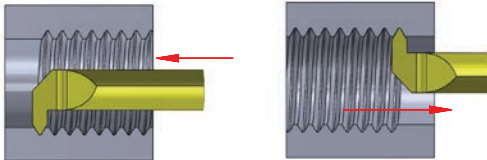

Linksgewinde  
thread left hand

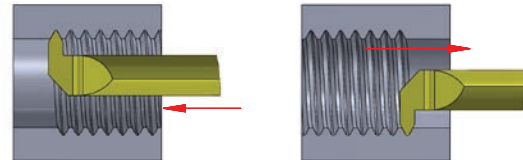

## Zustellungsvarianten

Radiale Zustellung	wechselnde Flankenzustellung	einseitige Flankenzustellung
Die meist verwendete Methode um Gewinde herstellen. Beide Schneiden sind gleichzeitig im Eingriff.	Die Schneiden werden wechselnd eingesetzt.	Nur eine Schneidewird für die komplette Gewindeerstellung eingesetzt.
Problematische Spanbildung, dadurch hohe Schnittkräfte und Verschleiß am Werkzeug und Bauteil.	Reduzierung des Schnittdrucks, höhere Standzeit und bessere Spanbildung.	Reduzierung des Schnittdrucks und bessere Spanbildung, aber einseitige Abnutzung des Werkzeugs.

### Infeed possibilities

Radial infeed	alternating flank infeed	flank infeed
The most used method for threading. both sides are at the same time in process.	The flanks are alternating used.	Only one cutting edge is used for the complete thread.
Problematic chip education, high cutting force and wearness at insert and work piece.	Reduced cutting force, higher state time and chip education.	Reduced cutting force and better chip education, but one-sided wearness.

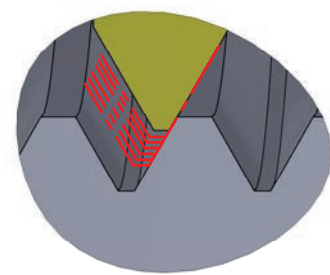
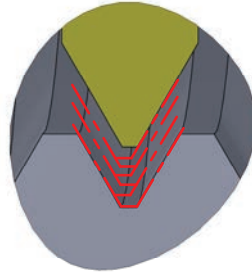
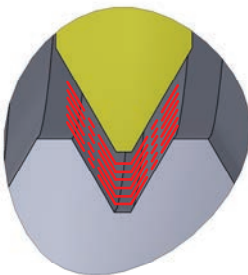

## ULTRAMINI

Bohrungsbearbeitung  
ab Ø 0.2 mm

grooving, boring and profiling  
starting at Ø 0.2 mm

## Technische Hinweise

Hartmetallsorten und Beschichtungen

Technical instructions,  
carbide grades and coatings



### K10F

Universell einsetzbares Feinkornhartmetall mit guter Verschleißfestigkeit. Unbeschichtet geeignet für Anwendungen mit niedrigen und mittleren Schnittgeschwindigkeiten, sowie die Bearbeitung von Nicht-eisenmetallen.

All purpose micrograin carbide with good abrasion resistance. Uncoated for applications with low or medium cutting speeds and machining of non-ferrous materials.

### CBN

Zähe CBN-Sorte für Anwendungen mit niedrigen Schnittgeschwindigkeiten. Geeignet für gehärtete Stähle, unterbrochene Schnitte und Grauguss.

Ductile CBN grade for applications with lower cutting speed. Suitable for hardened steel, interrupted cuts and cast iron.

### CN45F

Universell einsetzbare PVD-TiN-Beschichtung. Diese Allround-Sorte ist für niedrige und mittlere Schnittgeschwindigkeiten mit Einschränkung bei NE-Metallen

PVD-TiN coating - all purpose, all around grade is suitable for low and medium cutting speed with restrictions on non-ferrous materials.

### AL41F

Sehr universell einsetzbare TiAlN-Beschichtung mit hoher Temperaturbeständigkeit bei hoher Härte. Sehr gut geeignet auch für NE-Metalle.

TiAlN coating - very universal with a high resistance to high temperature and hardness. Very suitable also for non-ferrous metals.

### PD2F

Beschichtung für den universellen Einsatz bei niedrigen und mittleren Schnittgeschwindigkeiten.

Coating for universal use with medium and low speed.

### XC2A

Beschichtung mit einer excellenten Warmhärte, Oxidationsbeständigkeit und thermischen Isolationsfähigkeit. Ideal für Hartzerspannung >60HRC

Coating with excellent hot hardness, high oxidation resistance and thermal insulation capacity. Perfect for hard machining >60 HRC.

## ULTRAMINI

Bohrungsbearbeitung  
ab  $\varnothing$  0.2 mm

grooving, boring and profiling  
starting at  $\varnothing$  0.2 mm

## Technische Hinweise

Hartmetallsorten und Beschichtungen

Technical instructions,  
carbide grades and coatings

### P01C

Beschichtung für die Bearbeitung in zähen Materialien bei niedrigen und mittleren Schnittgeschwindigkeiten.

Coating for the processing in tough material with medium or low cutting speed



### P03C

Beschichtung für die Bearbeitung von schwer zerspanbaren Materialien. Sehr gut auch für die Trockenbearbeitung geeignet.

Coating for materials which are difficult to machine. Perfect to use for dry machining.

### P07C

Beschichtung für die Bearbeitung von Titan, Edelstahl und Molybdän.

Coating to machine titanium, stainless steel and molybdenum.

### P18C

Universell einsetzbare Hochleistungsschicht mit hoher Oxidationsbeständigkeit, Verschleißfestigkeit und Warmhärte.

Very universal high performance coating with high oxidation resistance, wear resistance and hot hardness resistance.

### NEME

Beschichtung für die Bearbeitung von Aluminium, Al-Legierungen, NE-Metallen und Composite-Werkstoffen.

Coating for machining aluminium, alloys, non-ferrous metals and composite materials.

# ULTRAMINI

Bohrungsbearbeitung  
ab Ø 0.2 mm

grooving, boring and profiling  
starting at Ø 0.2 mm

# Technische Hinweise

Schnittdaten

Technical instructions,  
cutting data



	Werkstoff	Festigkeit	Werkstoff-Nr	Werkstoffbezeichnung	Werkstoff-Nr
P	Allgemeiner Baustahl	< 800 N/mm2	1.0037	St37-2	1.0570
	Automatenstahl	< 800 N/mm2	1.0718	9SMnPb28	1.0727
	Einsatzstahl unlegiert	< 800 N/mm2	1.0401	C15	1.0481
	Einsatzstahl legiert	< 1000 N/mm2	1.7331	16MnCr5 (EC80)	1.7015
	Vergütungsstahl unlegiert	< 850 N/mm2	1.0503	C45	1.1191
	Vergütungsstahl unlegiert	< 1000 N/mm2	1.0601	C60	1.1221
	Vergütungsstahl legiert	< 800 N/mm2	1.5131	50MnSi4	1.7030
	Vergütungsstahl legiert	< 1300 N/mm2	1.5755	31NiCr14	1.7033
	Stahlguss	< 850 N/mm2	0.9650	G-X260Cr27	1.6750
	Nitrierstahl	< 1000 N/mm2	1.8504	34CrAl6	1.8507
	Nitrierstahl	< 1200 N/mm2	1.8515	31CrMo12	1.8523
	Wälzlagerstahl	< 1200 N/mm2	1.3505	100Cr6 (W3)	1.3543
	Federstahl	< 1200 N/mm2	1.5026	55Si7	1.7176
	Schnellarbeitsstahl	< 1300 N/mm2	1.3344	S 6-5-3	1.3255
	Werkzeugstahl für Kaltarbeit	< 1300 N/mm2	1.2312	40CrMnMoS8 6	1.2379
	Werkzeugstahl für Warmbeit	< 1300 N/mm2	1.2343	X38CrMoV 5 1	1.2767
M	Stahl und Stahlguss rostfrei geschwefelt	< 850 N/mm2	1.4305	X8CrNiS18 9	1.4105
	Nichtrostender Stahl, ferritisch	< 750 N/mm2	1.4510	X3CrTi17	1.4528
	Nichtrostender Stahl, martensitisch	< 900 N/mm2	1.4034	X46Cr13	1.4116
	Nichtrost. Stahl, ferritisch/martensit.	<1100 N/mm2	1.4313	X3CrNi13-4	1.4028
	Nichtrost. Stahl, austenitisch/ferritisch	< 850 N/mm2	1.4460	X8CrNiMo27 5	1.4821
	Nichtrostender Stahl, austenitisch	< 750 N/mm2	1.4301	X5CrNi18-10	1.4571
K	Hitzebeständig	< 1100 N/mm2	1.4747	X80CrNiSi20	1.4876
	Grauguss mit Lammellengraphit	100-350N/mm2	0.6010	GG10	0.6025
	Grauguss mit Lammellengraphit	300-1000N/mm2	0.6030	GG30	0.6045
	Kugelgraphitguss	300-500N/mm2	0.7040	GGG40	0.7050
	Kugelgraphitguss	550-800N/mm2	0.7060	GGG60	0.7080
	Temperguss weis	350-450N/mm2	0.8035	GTW35	0.8045
	Temperguss weis	500-650N/mm2	0.8055	GTW55	0.8065
	Temperguss schwarz	350-450N/mm2	0.8135	GTS35	0.8145
N	Temperguss schwarz	500-700N/mm2	0.8155	GTS55	0.8170
	Aluminium ( unlegiert, niedrig legiert )	< 350 N/mm2	3.0255	Al99,5	3.3308
	Aluminiumlegierungen < 0,5% Si	< 500 N/mm2	3.0515	AlMn1	3.1355
	Aluminiumlegierungen 0,5-10% Si	< 400 N/mm2	3.2152	GD-AlSi6Cu4	3.2373
	Aluminiumlegierungen 10-15% Si	< 400 N/mm2	3.2381	G-AlSi10Mg	3.5562
	Aluminiumlegierungen > 15% Si	< 400 N/mm2		G-AlSi17Cu4	
	Kupfer ( unlegiert, niedrig legiert )	< 350 N/mm2	2.0060	E-Cu57	2.0090
	Kupfer-Knetlegierungen	< 700 N/mm2	2.0240	CuZn15	2.0265
	Kupfer-Sonderlegierungen	< 200 HB	2.0916	CuAl5	2.1525
	Kupfer-Sonderlegierungen	< 300HB	2.0978	CuAl11Ni6Fe5	
	Kupfer-Sonderlegierungen	> 300 HB	2.1247	CuBe2F125	
	Messing kurzspanend, Bronze, Rotguss	< 600 N/mm2	2.0360	CuZn40 (Ms60)	2.0380
	Messing langspanend	< 600 N/mm2	2.0335	CuZn36 (Ms63)	2.1293
	Thermoplaste			Delrin, Hostalen	
	Duroplaste			Ferrozell, Bakelit	
	Faserverstärkte Kunststoffe			GFK (Glasfaserverstärkt )	
	Magnesium und Magnesiumlegierungen	< 850 N/mm2	3.5200	M2, MgMn2	3.5612
	Graphit			C8000, R8500X	
Wolfram und Wolframlegierungen			W-NiFe (Densimet W)		
Molybdän und Molybdänlegierungen			Mo , Mo-50Re		
S	Reinnickel		1.3911	RNi24	1.3927
	Nickellegierungen		1.3912	Ni36 (Invar)	1.3924
	Nickellegierungen	< 850 N/mm2	2.4360	S-NiCu 30 Fe	
	Nickel-Chromlegierungen		2.4886	SG-NiMo16Cr16W	2.4610
	Nickel- und Kobaltlegierungen	< 1300 N/mm2	2.4632	NiCr20Co18Ti	2.4631
	Nickel- und Kobaltlegierungen	< 1300 N/mm2	2.4634	NiCo20Cr15MoAlTi	2.4654
	Hochwarmfeste Legierungen	< 1300 N/mm2		Hardox 400	1.4939
	Nickel-Kobalt-(Chrom-)legierungen	< 1400 N/mm2	2.4806	SG-NiCr20Nb, Inconel 82	2.4851
	Reintitan	< 900 N/mm2	3.7025	Ti99,8	3.7034
	Titanlegierungen	< 700 N/mm2	3.7114	TiAl5Sn2	3.7174
H	Titanlegierungen	< 1200 N/mm2	3.7164	TiAl5V4	3.7144
	Stahl gehärtet	< 45 HRc			
		46-55HRc			
		56-60 HRc			
	61-65 HRc				
	65-70 HRc				

### Vorschub f:

Stechdrehen: 0,01 - 0,03 mm/U

Ausdrehen / Kopieren: 0,02 - 0,08 mm/U

Axialstechen: 0,02 - 0,05 mm/U

### feed f:

grooving: 0,01 - 0,03 mm/Rev.

boring / profiling: 0,02 - 0,08 mm/Rev.

face grooving: 0,02 - 0,05 mm/Rev.

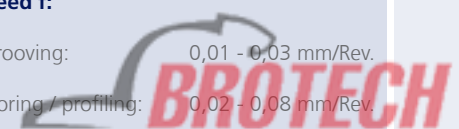

# ULTRAMINI

Bohrungsbearbeitung  
ab Ø 0.2 mm

grooving, boring and profiling  
starting at Ø 0.2 mm

# Technische Hinweise

Schnittdaten

Technical instructions,  
cutting data



Werkstoffbez.	Werkstoff-Nr	Werkstoffbez.	Vc K10F (m/min.)	Vc CN45F (m/min.)	Vc AL41F (m/min.)	Vc P18C (m/min.)	Vc P07C (m/min.)	Vc XC2A-NH (m/min.)
St52-3	1.0060	St60-2	30-130	30-180	80-200	80-200	80-200	
45S20	1.0757	46SPb2	30-130	40-200	80-200	80-200	80-200	
17Mn4	1.1141	C15E (CK15)	30-130	40-180	80-200	80-200	80-200	
13Cr3 (EC60)	1.5919	15CrNi6	15-90	30-140	80-160	80-160	80-160	
Ck45	1.0535	C55	15-90	30-100	80-140	80-140	80-140	
Ck60	1.0540	C50	15-90	30-100	80-160	80-160	80-160	
28Cr4	1.7225	42CrMo4	30-130	30-100	80-160	80-160	80-160	
34Cr4	1.3565	48CrMo4	15-90	30-100	80-150	80-150	80-150	
G5-20NiCrMo3 7	1.6582	G5-34 CrNiMo 6	30-130	40-200	80-200	80-200	80-200	
34AlMo5	1.8509	41CrAlMo7	15-90	30-100	70-140	70-140	70-140	
39CrMoV19 3	1.8550	34 CrAlNi 7	15-90	30-100	70-140	70-140	70-140	
X192CrMo17	1.3520	100 CrMn 6 (W4)	15-90	30-100	70-140	70-140	70-140	
55Cr3	1.7701	51CrMoV4						
S 18-1-2-5	1.3294	PMH56-5-3-8; ASP30						
X155CrVMo12 1	1.2316	X38CrMo16; RAMAX	15-45	30-100				
X45NiCrMo4	1.2842	90MnCrV8	15-45	30-100				
X4CrMoS18	1.4107	GX8CrNi12		30-100	80-160	80-160	80-160	
X105CrCoMo18 2	1.4016	X6Cr17		30-100	80-160	80-160	80-160	
X50CrMoV15	1.4106	X2CrMoSiS18-2-1		30-100	80-160	80-160	80-160	
X30Cr13	1.4104	X14CrMoS17		20-90	20-85	20-85	20-85	
X20CrNiSi25 4	1.4462	X2CrNiMoN22-5-3(Duplex)		20-65	20-75	20-75	20-75	
X6CrNiMoTi17 12 2	1.4449	X3CrNiMo18-12-3		20-80	20-65	20-65	20-65	
X10NiCrAlTi32-21	1.4825	GX25CrNiSi18-9		20-80	20-65	20-65	20-65	
GG25			30-110	70-150	30-180	30-180	30-180	
GG45			30-90	50-120	30-150	30-150	30-150	
GGG50			25-110	30-130	30-180	30-180	30-180	
GGG80			25-80	30-110	30-120	30-120	30-120	
GTW45			30-110	30-100	30-90	30-90	30-90	
GTW65			30-90	30-90	20-80	20-80	20-80	
GTS45			30-110	30-100	30-90	30-90	30-90	
GTS70			30-90	30-90	20-80	20-80	20-80	
Al99,9Mg0,5	3.0256	E-Al H	110-210	100-600	120-600	120-600	120-600	
AlCuMg2	3.3315	AlMg1	90-200	100-600	120-600	120-600	120-600	
GD-ALSi9Mg	3.2134	GD-ALSi5Cu1Mg	90-200	100-500	100-450	100-450	100-450	
G-MgAl6	3.2525	S-ALSi12	50-140	80-350	70-300	70-300	70-300	
G-ALSi25CuNiMg		G-ALSi21CuNiMg		80-200	60-150	60-150	60-150	
SF-Cu	2.1522	CuSi2Mn	50-140	70-160	60-150	60-150	60-150	
CuZn30	2.0321	CuZn37	60-150	80-180	100-180	100-180	100-180	
CuSi3Mn		Ampco 8-16	50-140	80-180	90-180	90-180	90-180	
		Ampco18-26	50-140	80-180	80-180	80-180	80-180	
		Ampco M-4	50-140	80-180	80-180	80-180	80-180	
CuZn39Pb2 (Ms58)	2.0410	CuZn44Pb2	80-160	100-200	120-220	120-220	120-220	
CuCrZr	2.1080	CuSn6Zn6	50-120	80-180	70-150	70-150	70-150	
Makrolon, Novodur Pertinax		Acrylglas, Polystyrol Resopal	40-120	70-160	80-180	80-180	80-180	
CFK (Kohlefaserverstärkt)		AFK (Amidfaserverstärkt)						
MgAl6Zn1	3.5812	MgAl8Zn1						
R8650		Technograph15						
W-Cu80/20		W93NiFe (DENAL)	15-70					
TZC, TZM		MHC , ODS						
RNi8	1.3926	RNi12		30-80	30-80	30-80	30-80	
Ni54	1.3921	Ni49		18-75	18-75	18-75	18-75	
NiCu 30 Fe		Monel 400		18-75	18-75	18-75	18-75	
NiMo16Cr16Ti		Hastelloy C-276			40-70	40-70	40-70	60 - 70
NiCr20TiAl		Nimonic 80		18-40	40-70	40-70	40-70	60 - 70
NiCr19Co14Mo4Ti		Waspaloy		18-40	40-70	40-70	40-70	60 - 70
X12CrNiMo12	1.4980	X6NiCrTiMoVB25-15-2		15-30	40-70	40-70	40-70	60 - 70
NiCr23Fe, Inconel 601	2.4667	SG-NiCr19NbMoTi		15-30	40-70	40-70	40-70	60 - 70
Ti99,7	3.7064	Ti99,5			40-70	40-70	70-150	
TiAl6V6Sn2	3.7124	TiCu2			40-70	40-70	70-150	
TiAl6Sn2Zr4Mo2	3.7154	TiAl6Zr5			40-70	40-70	70-150	
								50 - 120
								50 - 120
								50 - 120

### Vorschub f:

Stechdrehen: 0,01 - 0,03 mm/U  
 Ausdrehen / Kopieren: 0,02 - 0,08 mm/U  
 Axialstechen: 0,02 - 0,05 mm/U

### feed f:

grooving: 0,01 - 0,03 mm/Rev.  
 boring / profiling: 0,02 - 0,08 mm/Rev.  
 face grooving: 0,02 - 0,05 mm/Rev.

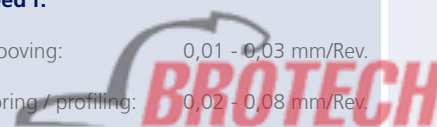



# ULTRAMINI

Bohrungsbearbeitung  
ab Ø 0.2 mm

grooving, boring and profiling  
starting at Ø 0.2 mm

# Technische Hinweise

Schnittdaten

Technical instructions,  
cutting data



	MATERIAL	STRENGTH (psi)	MATERIAL NUMBER	MATERIAL DESCRIPTION	ANSI	MATERIAL NUMBER	MATERIAL DESCRIPTION
P	General Construction Steel	< 116030	1.0037	St37-2	A284	1.0570	St52-3
	Free-cutting steel	< 116030	1.0718	95MnPb28	12L13	1.0727	45S20
	Non-Alloyed Steel	< 116030	1.0401	C15	1015	1.0481	17Mn4
	Alloy Steel	< 145038	1.7331	16MnCr5 (EC80)	5120	1.7015	13Cr3 (EC60)
	Compensation Steel Unalloyed	< 123282	1.0503	C45	1045	1.1191	Ck45
	Compensation Steel Unalloyed	< 145038	1.0601	C60	1060	1.1221	Ck60
	Alloy Steel	< 116030	1.5131	50MnSi4		1.7030	28Cr4
	Alloy Steel	< 188549	1.5755	31NiCr14		1.7033	34Cr4
	Cast Steel	< 123282	0.9650	G-X260Cr27		1.6750	GS-20NiCrMo3 7
	Nitriding Steel	< 145038	1.8504	34CrAl6		1.8507	34AlMo5
	Nitriding Steel	< 174045	1.8515	31CrMo12		1.8523	39CrMoV19 3
	Bearing Steel	< 174045	1.3505	100Cr6 (W3)	52100	1.3543	X192CrMo17
	Bearing Steel	< 174045	1.5026	55Si7	-	1.7176	55Cr3
	High Speed Steel	< 188549	1.3344	S 6-5-3		1.3255	S 18-1-2-5
	Tool Steel for Cold Work	< 188549	1.2312	40CrMnMoS8 6		1.2379	X155CrVMo12 1
Tool Steel for Warm Work	< 188549	1.2343	X38CrMoV 5 1	H11	1.2767	X45NiCrMo4	
M	Steel and cast steel rostfrei sulfurized	< 123282	1.4305	X8CrNiS18 9	303	1.4105	X4CrMoS18
	Stainless Steel, Ferritic	< 108778	1.4510	X3CrTi17		1.4528	X105CrCoMo18 2
	Stainless Steel, Martensitic	< 130534	1.4034	X46Cr13	-	1.4116	X50CrMoV15
	Non-rusting. Steel, Ferritic / Martensite	< 159542	1.4313	X3CrNi13-4		1.4028	X30Cr13
	Non-rusting. Steel, Austenitic / Ferritic	< 123282	1.4460	X8CrNiMo27 5	S32900	1.4821	X20CrNiSi25 4
	Stainless Steel, Austenitic	< 108778	1.4301	X5CrNi18-10	304	1.4571	X6CrNiMoTi17 12 2
	Heat Resistant	< 159542	1.4747	X80CrNiSi20		1.4876	X10NiCrAlTi32-21
K	Gray Cast Iron with Lamellar Graphite	14504-50763	0.6010	GG10	CLASS20	0.6025	GG25
	Gray Cast Iron with Lamellar Graphite	43511-145038	0.6030	GG30	CLASS45	0.6045	GG45
	Ball Graphite Castings	43511-72519	0.7040	GGG40	60-40-18	0.7050	GGG50
	Ball Graphite Castings	79771-116030	0.7060	GGG60	-	0.7080	GGG80
	Malleable Cast Iron	50763-65367	0.8035	GTW35	-	0.8045	GTW45
	Malleable Cast Iron	72519-94274	0.8055	GTW55	-	0.8065	GTW65
	Malleable Cast Iron Black	50763-65267	0.8135	GTS35	32510	0.8145	GTS45
	Malleable Cast Iron Black	72519-101526	0.8155	GTS55	50005	0.8170	GTS70
N	Aluminum ( unalloyed, low alloy )	< 50763	3.0255	Al99,5	1000	3.3308	Al99,9Mg0,5
	Aluminum Alloys < 0,5%	< 72519	3.0515	AlMn1		3.1355	AlCuMg2
	Aluminum Alloys 0,5-10%	< 58015	3.2152	GD-ALSi6Cu4		3.2373	GD-ALSi9Mg
	Aluminum Alloys 10-15%	< 58015	3.2381	G-ALSi10Mg	-	3.5562	G-MgAl6
	Aluminum Alloys > 15%	< 58015		G-ALSi17Cu4			G-ALSi25CuNiMg
	Copper (unalloyed, low alloy)	< 50763	2.0060	E-Cu57		2.0090	SF-Cu
	Copper Wrought Alloys	< 101526	2.0240	CuZn15	C23000	2.0265	CuZn30
	Copper Special Alloys	< 200 HB	2.0916	CuAl5		2.1525	CuSi3Mn
	Copper Special Alloys	< 300HB	2.0978	CuAl11Ni6Fe5			
	Copper Special Alloys	> 300 HB	2.1247	CuBe2F125			
	Brass Short-Spanning, Bronze, Gunmetal	< 87023	2.0360	CuZn40 (Ms60)	C28000	2.0380	CuZn39Pb2 (Ms58)
	Brass Long-Spanning	< 87023	2.0335	CuZn36 (Ms63)	C36000	2.1293	CuCrZr
	Thermoplastics			Delrin, Hostalen			Makrolon, Novodur
	Thermosets			Ferrozell, Bakelit			Pertinax
	Fiber Reinforced Plastics			GFK (Glasfaserverstärkt)			CFK (Kohlefaserverstärkt)
	Magnesium and Magnesium Alloys	< 123282	3.5200	M2, MgMn2		3.5612	MgAl6Zn1
	Graphite			C8000, R8500X			R8650
Tungsten and Tungsten Alloys			W-NiFe (Densimet W)			W-Cu80/20	
Molybdenum and Molybdenum Alloys			Mo, Mo-50Re			TZC, TZM	
S	Pure Nickel		1.3911	RNi24		1.3927	RNi8
	Nickel Alloys		1.3912	Ni36 (Invar)		1.3924	Ni54
	Nickel Alloys	< 123282	2.4360	S-NiCu 30 Fe			NiCu 30 Fe
	Nickel-Chromium Alloy		2.4886	SG-NiMo16Cr16W		2.4610	NiMo16Cr16Ti
	Nickel and Cobalt Alloys	< 188549	2.4632	NiCr20Co18Ti		2.4631	NiCr20TiAl
	Nickel and Cobalt Alloys	< 188549	2.4634	NiCo20Cr15MoAlTi		2.4654	NiCr19Co14Mo4Ti
	High-Temperature Resistant Alloys	< 188549		Hardox 400		1.4939	X12CrNiMo12
	Nickel-Cobalt-(Chrome-) Alloys	< 203053	2.4806	SG-NiCr20Nb, Inconel 82		2.4851	NiCr23Fe, Inconel 601
	Pure Titanium	< 130534	3.7025	Ti99,8		3.7034	Ti99,7
	Titanium Alloys	< 101526	3.7114	TiAl5Sn2	-	3.7174	TiAl6V6Sn2
Titanium Alloys	< 174045	3.7164	TiAl5V4		3.7144	TiAl6Sn2Zr4Mo2	
H	Hardened Steel	< 45 HRC					
		46-55HRC					
		56-60 HRC					
		61-65 HRC					
	65-70 HRC						

Data on this page is for reference and planning only. Materials and processes should be tested in your environment to achieve desired results.

feed f:

groove: 0.0004 - 0.0012 in/Rev.

copy turning: 0.0008 - 0.0031 in/Rev.

axial groove: 0.0008 - 0.002 in/Rev.

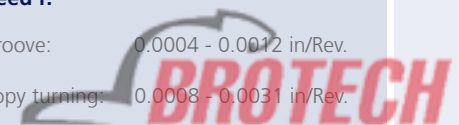

# ULTRAMINI

Bohrungsbearbeitung  
ab Ø 0.2 mm

grooving, boring and profiling  
starting at Ø 0.2 mm

# Technische Hinweise

Schnittdaten

Technical instructions,  
cutting data



ANSI	MATERIAL NUMBER	MATERIAL DESCRIPTION	ANSI	K10F (SFM)	CN45F (SFM)	AL41F (SFM)	P18C (SFM)	P07C (SFM)	XC2A-NH (SFM)
	1.0060	St60-2	A572	98-426	98-591	262-656	262-656	262-656	
	1.0757	46SPb2		98-426	131-656	262-656	262-656	262-656	
	1.1141	C15E (CK15)	1015	98-426	131-591	262-656	262-656	262-656	
	1.5919	15CrNi6	3115	49-295	98-459	262-525	262-525	262-525	
1045	1.0535	C55	1055	49-295	98-328	262-459	262-459	262-459	
1060	1.0540	C50		49-295	98-328	262-525	262-525	262-525	
	1.7225	42CrMo4	4140	98-426	98-328	262-525	262-525	262-525	
5132	1.3565	48CrMo4		49-295	98-328	262-492	262-492	262-492	
	1.6582	GS-34 CrNiMo 6	4337	98-426	131-656	262-656	262-656	262-656	
	1.8509	41CrAlMo7	A355	49-295	98-328	230-459	230-459	230-459	
	1.8550	34 CrAlNi 7		49-295	98-328	230-459	230-459	230-459	
	1.3520	100 CrMn 6 (W4)		49-295	98-328	230-459	230-459	230-459	
	1.7701	51CrMoV4							
1015	1.3294	PMH56-5-3-8; ASP30							
D2	1.2316	X38CrMo16; RAMAX		49-148	98-328				
	1.2842	90MnCrV8	02	49-148	98-328				
430F	1.4107	GX8CrNi12			98-328	262-525	262-525	262-525	
	1.4016	X6Cr17	430		98-328	262-525	262-525	262-525	
	1.4106	X2CrMoSi18-2-1			98-328	262-525	262-525	262-525	
420F	1.4104	X14CrMoS17	430 F		66-295	66-279	66-279	66-279	
	1.4462	X2CrNiMoN22-5-3 (Duplex)	UNS31803		66-213	66-246	66-246	66-246	
316 Ti	1.4449	X3CrNiMo18-12-3	317		66-262	66-213	66-213	66-213	
B163	1.4825	GX25CrNiSi18-9			66-262	66-213	66-213	66-213	
A48-40 B				98-361	230-492	98-591	98-591	98-591	
				98-295	164-394	98-492	98-492	98-492	
65-45-12				82-361	98-426	98-591	98-591	98-591	
120-90-02				82-262	98-361	98-394	98-394	98-394	
				98-361	98-328	98-295	98-295	98-295	
				98-295	98-295	66-262	66-262	66-262	
				98-361	98-328	98-295	98-295	98-295	
				98-295	98-295	66-262	66-262	66-262	
	3.0256	E-Al H		361-689	328-1969	394-1968	394-1969	394-1969	
2024	3.3315	AlMg1		295-656	328-1969	394-1968	394-4969	394-1969	
	3.2134	GD-AlSi5Cu1Mg		295-656	328-1640	328-1476	328-1476	328-1476	
	3.2525	S-AlSi12		164-459	262-1148	230-984	230-984	230-984	
		G-AlSi21CuNiMg			262-656	197-492	197-492	197-492	
	2.1522	CuSi2Mn		164-459	230-525	197-492	197-492	197-492	
	2.0321	CuZn37		197-492	262-591	328-591	328-591	328-591	
		Ampco 8-16		164-459	262-591	295-591	295-591	295-591	
		Ampco18-26		164-459	262-591	262-591	262-591	262-591	
		Ampco M-4		164-459	262-591	262-591	262-591	262-591	
	2.0410	CuZn44Pb2		262-525	328-656	394-722	394-722	394-722	
	2.1080	CuSn6Zn6		164-394	262-591	230-492	230-492	230-492	
		Acrylglas, Polystyrol		131-394	230-525	262-591	262-591	262-591	
		Resopal							
		AFK (Amidfaserverstärkt)							
	3.5812	MgAl8Zn1							
		Technograph15							
		W93NiFe (DENAL)		49-230					
		MHC , ODS							
	1.3926	RNi12			98-262	98-262	98-262	98-262	
	1.3921	Ni49			59-246	59-246	59-246	59-246	
		Monel 400			59-246	59-246	59-246	59-246	
		Hastelloy C-276				131-230	131-230	131-230	197-230
		Nimonic 80			59-131	131-230	131-230	131-230	197-230
		Waspaloy			59-131	131-230	131-230	131-230	197-230
904L	1.4980	X6NiCrTiMoVB25-15-2			49-98	131-230	131-230	131-230	197-230
	2.4667	SG-NiCr19NbMoTi			49-98	131-230	131-230	131-230	197-230
	3.7064	Ti99,5				131-230	131-230	230-192	
	3.7124	TiCu2				131-230	131-230	230-192	
	3.7154	TiAl6Zr5				131-230	131-230	230-192	
									164-394
									164-394
									164-394

Data on this page is for reference and planning only. Materials and processes should be tested in your environment to achieve desired results.

feed f:

groove: 0.0004 - 0.0012 in/Rev.

copy turning: 0.0008 - 0.0031 in/Rev.

axial groove: 0.0008 - 0.002 in/Rev.

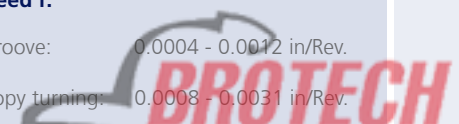





**MINICUT**



**Bohrungsbearbeitung ab Ø 7.8 mm**

**Grooving, boring and profiling  
starting at Ø 7.8 mm**



## MINICUT

Bohrungsbearbeitung

grooving, boring and profiling

## Übersicht

summary



Allgemeine Beschreibung

general instructions

... 123



**Klemmhalter  
Rundschaft**

**tool holder  
straight shank**

**Maße  
dimensions**

**Seite  
page**

<b>Typ 608 / 609 / 611 / 614</b>	Klemmhalter Stahl	tool holder steel	D min. 7.8	... 124
<b>Typ 616 / 618</b>	Klemmhalter Stahl	tool holder steel	D min. 16	... 125
<b>Typ 608 / 609</b>	Klemmhalter Hartmetall	tool holder carbide	D min. 7.8	... 126
<b>Typ 611</b>	Klemmhalter Hartmetall	tool holder carbide	D min. 11	... 127
<b>Typ 614</b>	Klemmhalter Hartmetall	tool holder carbide	D min. 14	... 128
<b>Typ 616</b>	Klemmhalter Hartmetall	tool holder carbide	D min. 16	... 129
<b>Typ 618</b>	Klemmhalter Hartmetall	tool holder carbide	D min. 18	... 130
<b>Typ V08 / V11</b>	Flexohalter V	Flexo-toolholder V	D min. 8 / 11	...131
<b>Typ 614.A / 618.A</b>	Klemmhalter Axialbearbeitung	tool holder face grooving	D min. 12 / 14 / 16 / 18	... 132

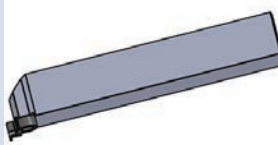

**Klemmhalter  
Quadratschaft**

**tool holder  
square shank**

**Maße  
dimensions**

**Seite  
page**

<b>Typ 614.SQ / 618.SQ</b>	Klemmhalter Stahl, Quadratschaft Axialbearbeitung	tool holder steel, square shank face grooving	D min. 12 / 14 / 16 / 18	... 133
<b>Typ 614.SQ.A / 618.SQ.A</b>	Klemmhalter Stahl, Quadratschaft Axialbearbeitung, abgesetzte Version	tool holder steel, square shank face grooving with offset	D min. 12 / 14 / 16 / 18	... 134

## MINICUT

Bohrungsbearbeitung

grooving, boring and profiling

## Übersicht

summary

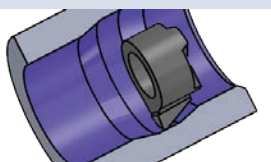

### Schneideinsätze Ausdrehen und Kopieren

### inserts boring and profiling

### Maße dimensions

### Seite page

<b>Typ Ausdrehen und Kopieren</b>	allgemein	type boring and profiling, general	D min. 7.8 - 15.5	... 136
<b>Typ Ausdrehen und Kopieren</b>	von gehärteten Teilen mit CBN	type boring and profiling, of hardened parts with CBN	D min. 7.8 - 15.5	... 137
<b>Typ Ausdrehen und Kopieren</b>	allgemein, Innenfreistiche DIN 509	type boring and profiling, general, undercuts DIN 509	D min. 7.8 - 20	... 138
<b>Typ Ausdrehen und Kopieren</b>	Ausdrehen mit spezieller Spantreppe	type boring and profiling, boring with special chipbreaker	D min. 8 / 9 / 11 t max. 0.5	... 139
<b>Typ Ausdrehen und Kopieren</b>	Rückwärtsdrehen	type boring and profiling, backboring	D min. 7.8 - 13.8	... 140

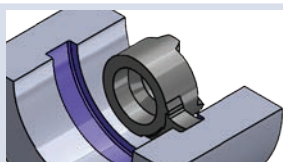

### Schneideinsätze Stechdrehen

### inserts grooving

### Maße dimensions

### Seite page

<b>Typ Stechdrehen</b>	für Sicherungsringe DIN 471/472 und Stechdrehen allgemein	type grooving, for circlips DIN 471/472 and grooving	D min. 8	... 142
<b>Typ Stechdrehen</b>	für Sicherungsringe DIN 471/472 und Stechdrehen allgemein	type grooving, for circlips DIN 471/472 and grooving	D min. 9	... 143
<b>Typ Stechdrehen</b>	für Sicherungsringe DIN 471/472 und Stechdrehen allgemein	type grooving, for circlips DIN 471/472 and grooving	D min. 11	... 144
<b>Typ Stechdrehen</b>	für Sicherungsringe DIN 471/472 und Stechdrehen allgemein	type grooving, for circlips DIN 471/472 and grooving	D min. 14	... 145
<b>Typ Stechdrehen</b>	für Sicherungsringe DIN 471/472 und Stechdrehen allgemein	type grooving, for circlips DIN 471/472 and grooving	D min. 16	... 146
<b>Typ Stechdrehen</b>	Stechdrehen allgemein	type grooving, general use	D min. 18 / 20 t max. = 6 / 8	... 147
<b>Typ Stechdrehen</b>	Stechdrehen allgemein, große Einstechtiefe	type grooving, general use, maximum depth of groove	D min. 16 / 17 t max. = 5.5 / 6.5	... 148

↳ ...

## MINICUT

Bohrungsbearbeitung

grooving, boring and profiling

## Übersicht

summary

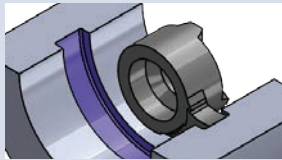

### Schneideinsätze Stechdrehen

### inserts grooving

### Maße dimensions

### Seite page

... ↴

<b>Typ Stechdrehen</b>	NC-Feindrehen	type grooving, NC-profiling	D min. 8 - 16	... <b>149</b>
<b>Typ Stechdrehen</b>	NC-Feindrehen, große Einstechtiefe	type grooving, NC-profiling, maximum depth of groove	D min. 16 / 17 t max. = 5.5 / 6.5	... <b>152</b>
<b>Typ Stechdrehen</b>	Stechdrehen und Kopieren Vollradius	type grooving, grooving and profiling, full radius	D min. 8 - 16 R 0.4 - 2.0	... <b>153</b>
<b>Typ Stechdrehen</b>	Ausdrehen und Fasen	type grooving, boring and chamfering	D min. 8 - 14	... <b>156</b>
<b>Typ Stechdrehen</b>	Vorstechen und Fasen	type grooving, pregrooving and chamfering	D min. 8 - 16	... <b>157</b>



### Schneideinsätze Gewindedrehen, innen

### inserts threading, internal

### Maße dimensions

### Seite page

<b>Typ Gewindedrehen</b>	metrisches ISO-Gewinde, Teilprofil, innen	type threading, metric ISO-thread, partial profile, internal	D min. 8 / 9 P = 0.5 - 3.5	... <b>158</b>
<b>Typ Gewindedrehen</b>	metrisches ISO-Gewinde, Teilprofil, innen	type threading, metric ISO-thread, partial profile, internal	D min. 11 / 14 / 16 P = 0.5 - 3.0	... <b>159</b>
<b>Typ Gewindedrehen</b>	metrisches ISO-Gewinde, Vollprofil, innen	type threading, metric ISO-thread, full profile, internal	D min. 9 / 11 P = 0.5 - 3.0	... <b>160</b>
<b>Typ Gewindedrehen</b>	metrisches ISO-Gewinde, Vollprofil, innen	type threading, metric ISO-thread, full profile, internal	D min. 14 / 16 P = 0.5 - 4.0	... <b>161</b>
<b>Typ Gewindedrehen</b>	NPT Vollprofil, innen	type threading, NPT full profile, internal	D min. 8	... <b>162</b>
<b>Typ Gewindedrehen</b>	Whitworth-Gewinde, Vollprofil, innen	type threading, Whitworth thread, full profile, internal	D min. 11 / 14 / 16	... <b>163</b>
<b>Typ Gewindedrehen</b>	Trapezgewinde, Teilprofil, innen	type threading, trapezoidal thread, partial profile, internal	D min. 9 / 10 / 11 P = 1.5 - 4.0	... <b>164</b>
<b>Typ Gewindedrehen</b>	Trapezgewinde, Teilprofil, innen	type threading, trapezoidal thread, partial profile, internal	D min. 14 / 16 P = 2.0 - 6.0	... <b>165</b>

# MINICUT

Bohrungsbearbeitung

grooving, boring and profiling

# Übersicht

summary

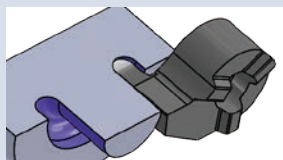

## Schneideinsätze Axialstechen

## inserts face grooving

## Maße dimensions

## Seite page

<b>Typ Axialstechen</b>	allgemein	type face grooving	D min. 14 / 18	... 166
<b>Typ Axialstechen</b>	am Zapfen vorbei	type face grooving, in pivots,	D min. 12 / 16	... 167
<b>Typ Axialstechen</b>	Vollradius	type face grooving, full radius	D min. 14 t max. 5	... 168
<b>Typ Axialstechen</b>	am Zapfen vorbei, Vollradius	type face grooving, in pivots, full radius	D min. 12 t max. 5	... 169



## Sets Minicut

## Halter und Schneiden (Rechte Ausführung)

## sets Minicut

## toolholder and inserts (righthand version)

## Maße dimensions

## Seite page

<b>SET-MC08-LF/R</b>	Auswahl RS008 / RS08	selection RS008 / RS08	D min. 8	... 171
<b>SET-MC11-LF/R</b>	Auswahl RS011 / RS11	selection RS011 / RS11	D min. 11	... 171
<b>SET-MC14-LF/R</b>	Auswahl RS014 / RS14	selection RS014 / RS14	D min. 14	... 172

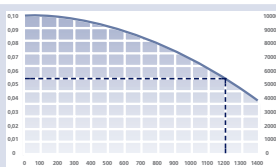

## Technische Hinweise

## Technical Instructions

## Seite page

Schnittwerte und Anzahl der Schnitte beim Gewindedrehen	cutting data and number of passes for threading	... 173
Gewinde schneiden	threading	...174
Hartmetallsorten und Beschichtungen	carbide grades and coatings	... 175
Schnittdaten	cutting data	... 177





## MINICUT

Bohrungsbearbeitung

grooving, boring and profiling

## Allgemeine Beschreibung

general instruction

### Minicut:

Bei dem System Minicut werden die austauschbaren Hartmetallschneiden mittels der bewährten Dreirippenverzahnung stirnseitig verschraubt. Diese gewährleistet beste Wiederholgenauigkeit bei einfachster Handhabung.

### Minicut:

In the system Minicut the indexible carbide inserts are frontal screwed by the proven interface. This guarantees best repeat accuracy by most simple handling.

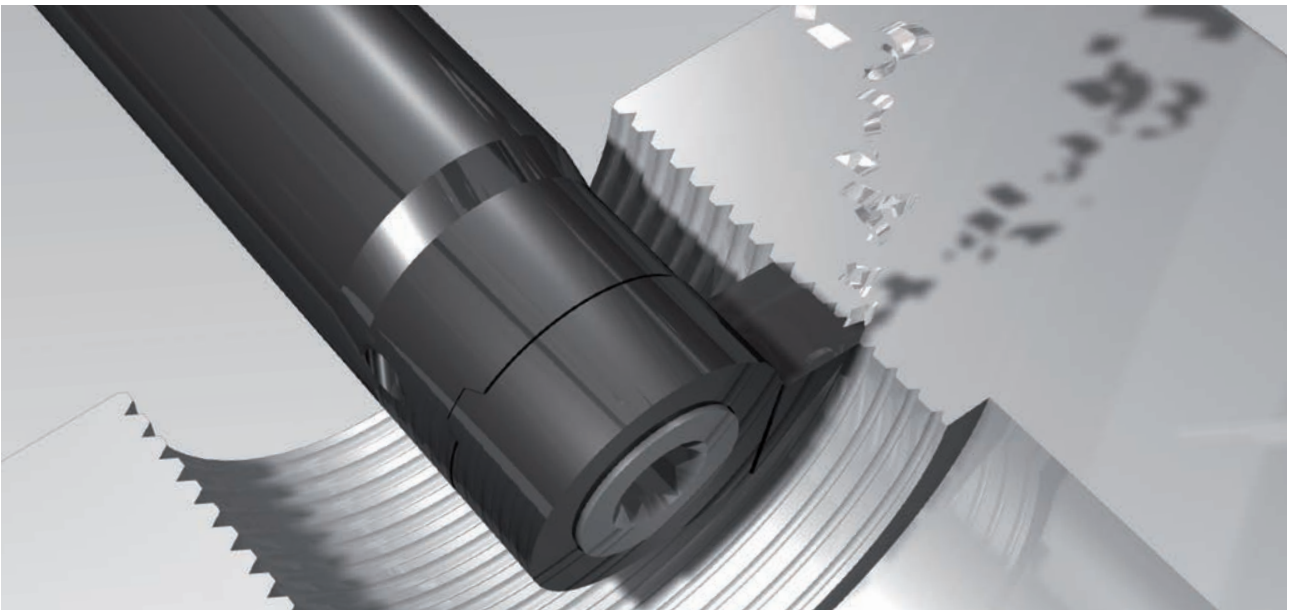
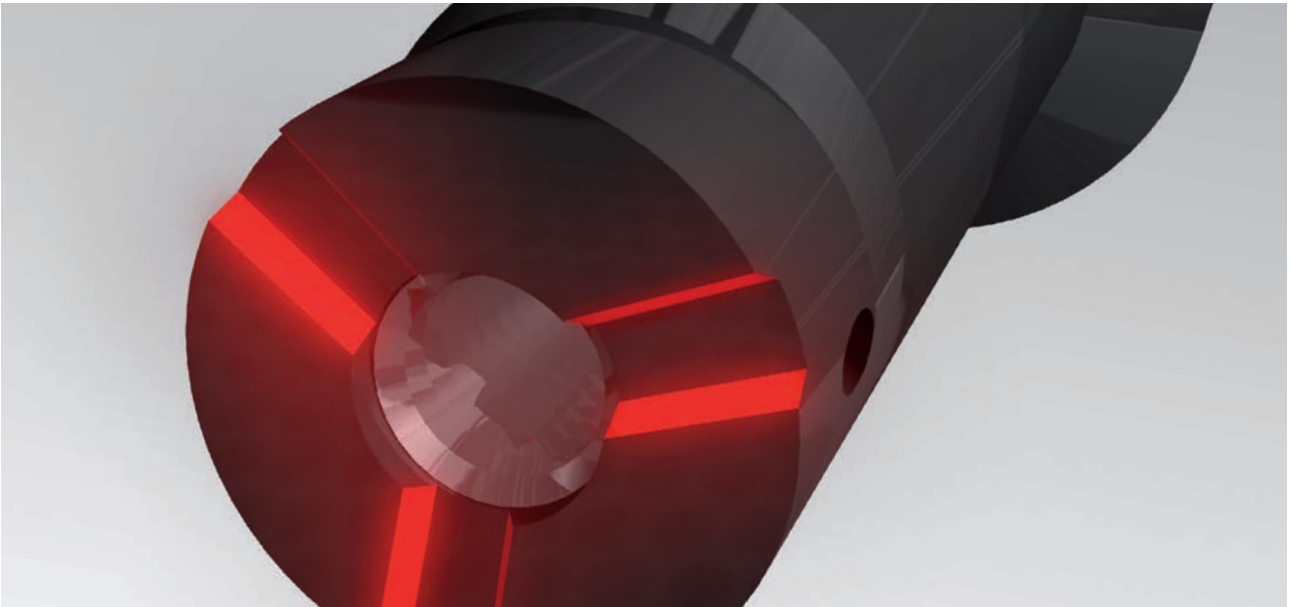

# MINICUT

Bohrungsbearbeitung

grooving, boring and profiling

# Typ 608 / 609 / 611 / 614

Klemmhalter Stahl

toolholder steel

D min. 7.8 mm

D min. 7.8 mm

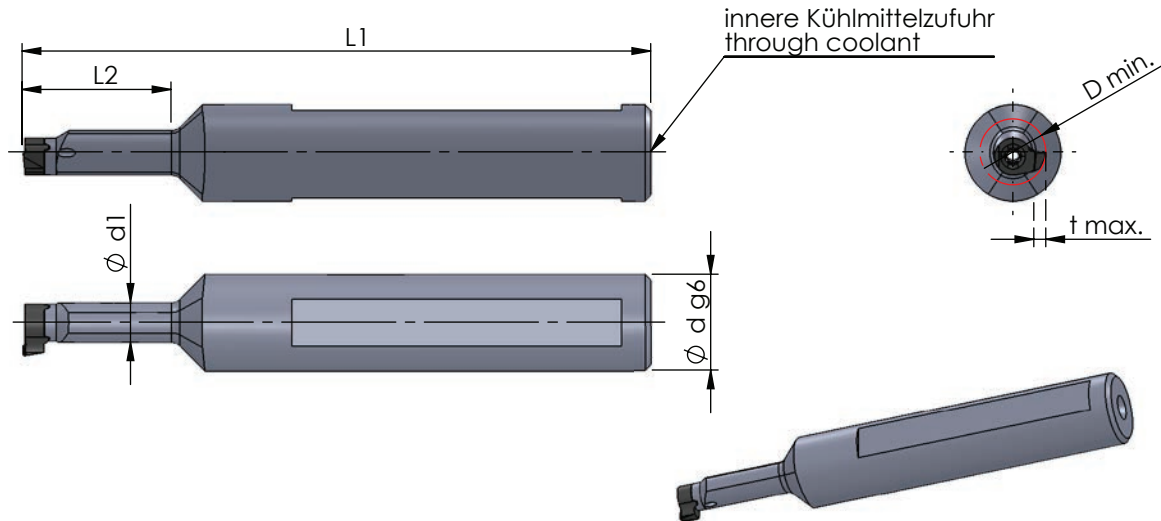

Abmessungen in mm

dimensions in mm

Bestellnummer part number	Ø d g6	Ø d (inch)	Ø d1	L1	L2	Typ: t max. / D min.	Spannschraube screw	Schraubenschlüssel wrench	Anzugs- drehmoment torque	für Schneidplatte use with insert
608.0158.1E.ST	15.875	5/8"	6x7	90	22	R/L S008: 1.0 / Ø8	M2.6-MC	T8	1.0-1.5 Nm	R/L S08 R/L S008
608.0016.1ST	16		6	80	12					
608.0016.1E.ST	16		6x7	90	22					
609.0158.1E.ST	15.875	5/8"	6.6x7.4	105	25	R/L S009: 1.8 / Ø9 R/L S09: 2.8 / Ø10	M2.6-MC	T8	2.0 Nm	R/L S09 R/L S009
609.0016.1ST	16		6.6x7.4	95	14					
609.0016.1E.ST	16		6.6x7.4	105	25					
611.0158.2E.ST	15.875	5/8"	8x9.5	110	29	R/L S011: 2.3 / Ø11	M3.5-MC	T10	2.5-3.0 Nm	R/L S11 R/L S011
611.0016.2ST	16		8	97	16					
611.0016.2E.ST	16		8x9.5	110	29					
614.0127.3ST	12.7	1/2"	9.5x11	100	18	R/L S014: 4.0 / Ø14 R/L S55: 5.5 / Ø16 R/L S65: 6.5 / Ø17	M4-MC	T15	4.0-4.5 Nm	R/L S14 R/L S014 R/L S55 R/L S65
614.0158.3E.ST	15.875	5/8"	9.5x11	120	38					
614.0016.3ST	16		9.5x11	100	18					
614.0016.3E.ST	16		9.5x11	120	38					

Bestellbeispiel:  
608.0158.1E.ST

order example:  
608.0158.1E.ST

# MINICUT

Bohrungsbearbeitung

grooving, boring and profiling

## Typ 616 / 618

Klemmhalter Stahl

toolholder steel

D min. 16 mm

D min. 16 mm

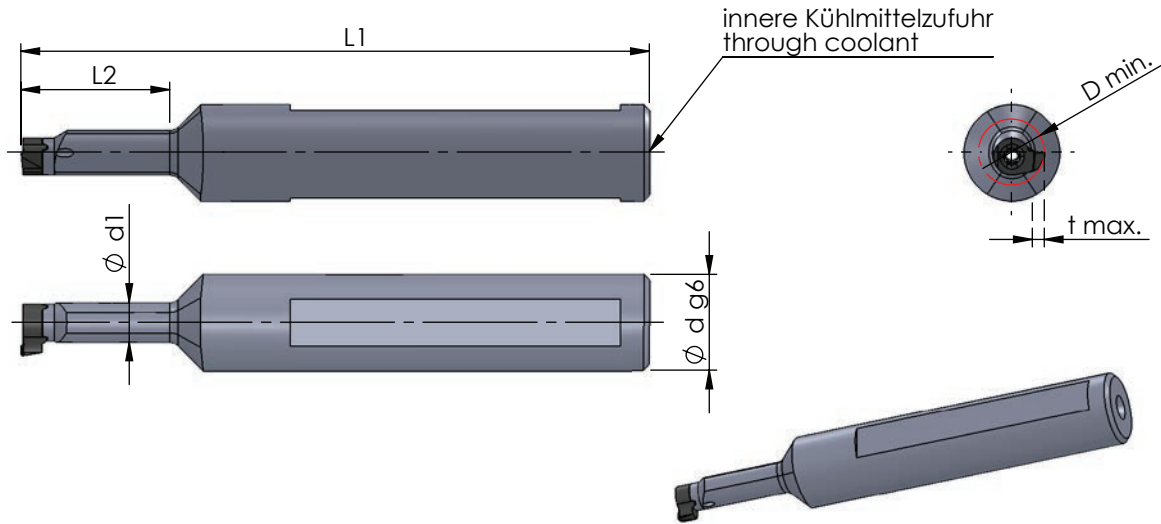

Abmessungen in mm

dimensions in mm

Bestellnummer part number	Ø d g6	Ø d1	L1	L2	Typ: t max. / D min.	Spannschraube screw	Schraubenschlüssel wrench	Anzugs- drehmoment torque	für Schneidplatte use with insert
616.0158.3E.ST	15.875	11x13.5	120	42	R/L S016: 4.3 / Ø16	M5-MC	T20	6.0-6.5 Nm	R/L S16 R/L S016
616.0016.3ST	16	11	100	22					
618.0020.3ST	20	11.5	95	25	R/L S18: 6 / Ø18 R/L S20: 8 / Ø20				R/L S18 R/L S20
618.0020.3E.ST	20	11.5	120	45					

Bestellbeispiel:  
616.0158.3E.ST

order example:  
616.0158.3E.ST

# MINICUT

Bohrungsbearbeitung

grooving, boring and profiling

## Typ 608 / 609

Klemmhalter Hartmetall

D min. 7.8 mm

toolholder carbide

D min. 7.8 mm

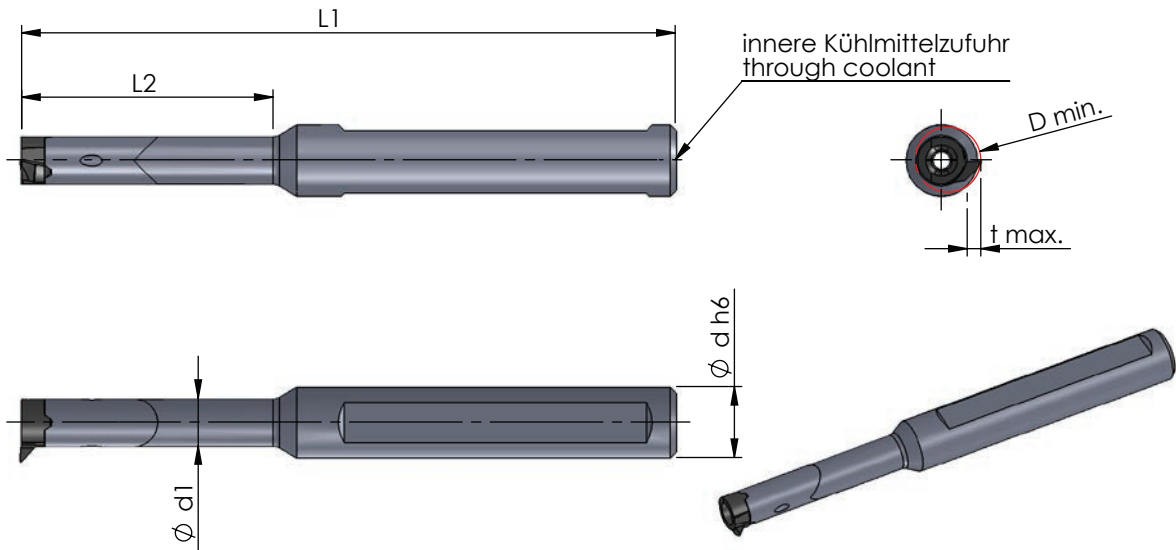

Abmessungen in mm

dimensions in mm



Bestellnummer part number	Ø d h6	Ø d1	L1	L2	Typ: t max. / D min.	Spannschraube screw	Schraubenschlüssel wrench	Anzugs- drehmoment torque	für Schneidplatte use with insert
608.0012.1HM	12	6	80	21	R/L S008: 1.0 / ø8	M2.6-MC	T8	2.0 Nm	R/L S08 R/L S008
608.0012.2HM	12	6	90	30					
608.0012.3HM	12	6	100	42					
608.0012.4HM	12	6	115	50					
608.0127.1HM	12.7	6	80	21					
608.0127.2HM	12.7	6	90	30					
608.0127.3HM	12.7	6	100	42	R/L S009: 1.8 / ø9 R/L S09.10: 2.8 / ø10		2.0 Nm	R/L S09 R/L S009	
609.0012.1HM	12	6.6x7.4	90	22					
609.0012.2HM	12	6.6x7.4	98	30					
609.0012.3HM	12	6.6x7.4	110	42					
609.0012.4HM	12	6.6x7.4	122	56					

Hinweis:  
Hartmetall-Klemmhalter mit beschädigter Schneidplattenaufnahme können durch unseren Reparaturservice in stand gesetzt werden.

Bestellbeispiel:  
608.0012.1HM

note:  
carbide-toolholder with damaged seating can be repaired by Dümmel.

order-example:  
608.0012.1HM



# MINICUT

Bohrungsbearbeitung

grooving, boring and profiling

# Typ 611

Klemmhalter Hartmetall

D min. 11 mm

toolholder carbide

D min. 11 mm

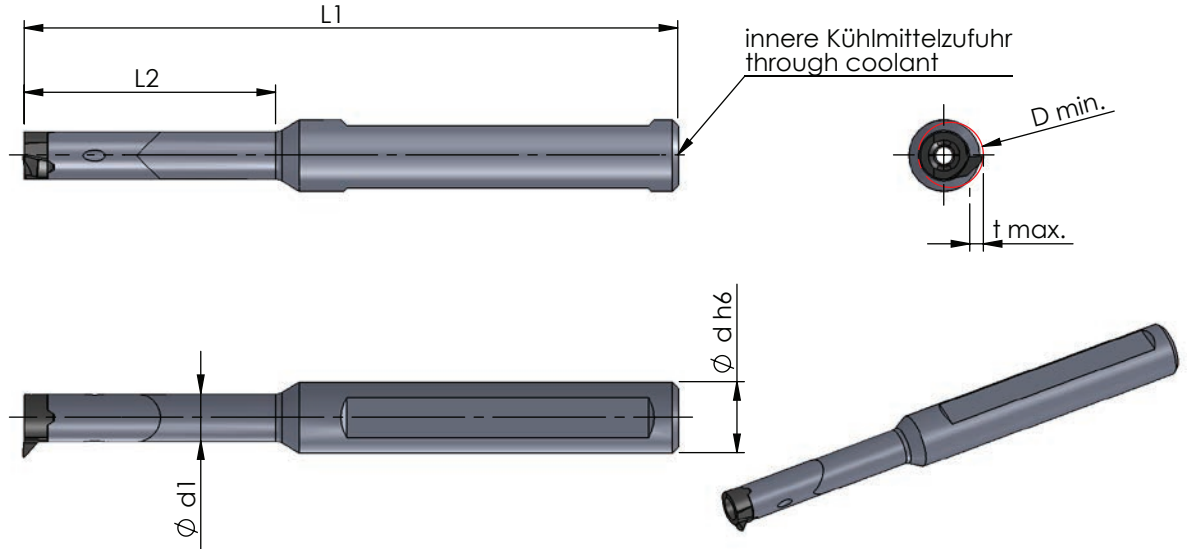

Abmessungen in mm

dimensions in mm

Bestellnummer part number	Ø d h6	Ø d1	L1	L2	Typ: t max. / D min.	Spannschraube screw	Schraubenschlüssel wrench	Anzugs- drehmoment torque	für Schneidplatte use with insert
611.0012.1HM	12	8	95	29	R/L S011: 2.3 / Ø11	M3.5-MC	T10	3.5 Nm	R/L S11 R/L S011
611.0012.2HM	12	8	110	42					
611.0012.3HM	12	8	120	56					
611.0012.4HM	12	8	130	64					
611.0127.1HM	12.7	8	95	29					
611.0127.2HM	12.7	8	110	42					
611.0127.3HM	12.7	8	120	56					

Hinweis:  
Hartmetall-Klemmhalter mit beschädigter Schneidplattenaufnahme können durch unseren Reparaturservice instand gesetzt werden.

Bestellbeispiel:  
611.0012.1HM

note:  
carbide-toolholder with damaged seating can be repaired by Dümmel.

order-example:  
611.0012.1HM



# MINICUT

Bohrungsbearbeitung

grooving, boring and profiling

# Typ 614

Klemmhalter Hartmetall

toolholder carbide

D min. 14 mm

D min. 14 mm

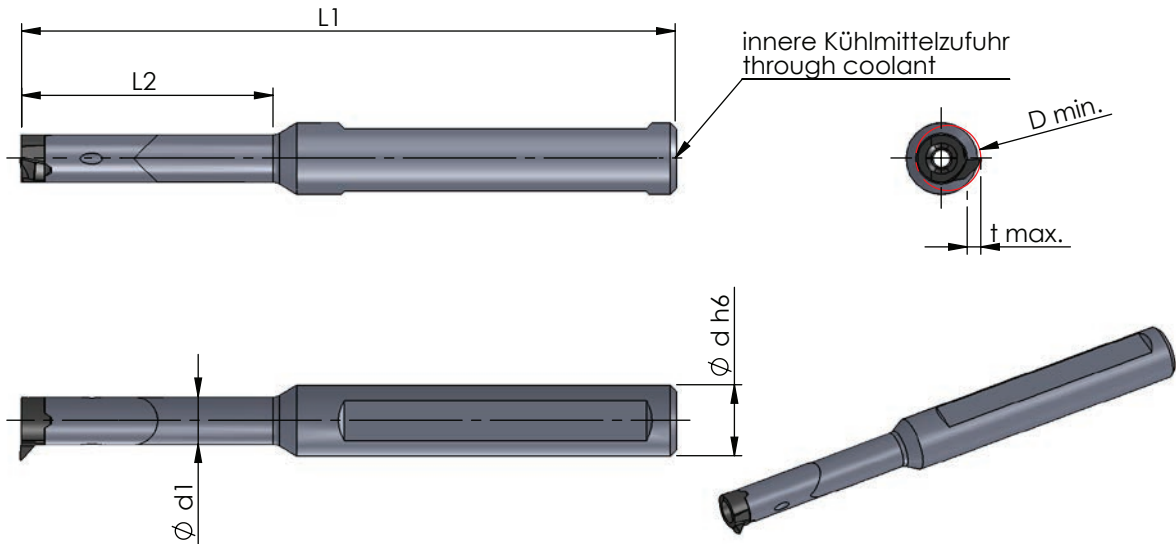

Abmessungen in mm

dimensions in mm

Bestellnummer part number	Ø d h6	Ø d1	L1	L2	Typ: t max. / D min.	Spannschraube screw	Schraubenschlüssel wrench	Anzugs- drehmoment torque	für Schneidplatte use with insert
614.0012.1HM	12	9.5x11	100	34	R/L S014: 4.0 / ø14 R/L S55: 5.5 / ø16 R/L S65: 6.5 / ø17	M4-MC	T15	4.5 Nm	R/L S14 R/L S014 R/L S55 R/L S65
614.0012.2HM	12	9.5x11	110	45					
614.0012.3HM	12	9.5x11	130	64					
614.0127.1HM	12.7	9.5x11	100	34					
614.0127.2HM	12.7	9.5x11	110	45					
614.0127.3HM	12.7	9.5x11	130	64					
614.0158.1HM	15.875	9.5x11	100	34					
614.0158.2HM	15.875	9.5x11	110	45					
614.0158.3HM	15.875	9.5x11	130	64					
614.0016.1HM	16	9.5x11	100	34					
614.0016.2HM	16	9.5x11	110	45					
614.0016.3HM	16	9.5x11	130	64					
614.0016.4HM	16	9.5x11	140	75					

Hinweis:  
Hartmetall-Klemmhalter mit beschädigter Schneidplattenaufnahme können durch unseren Reparaturservice in stand gesetzt werden.

Bestellbeispiel:  
614.0012.1HM

note:  
carbide-toolholder with damaged seating can be repaired by Dümmel.

order-example:  
614.0012.1HM



# MINICUT

Bohrungsbearbeitung

grooving, boring and profiling

# Typ 616

Klemmhalter Hartmetall

D min. 16 mm

toolholder carbide

D min. 16 mm

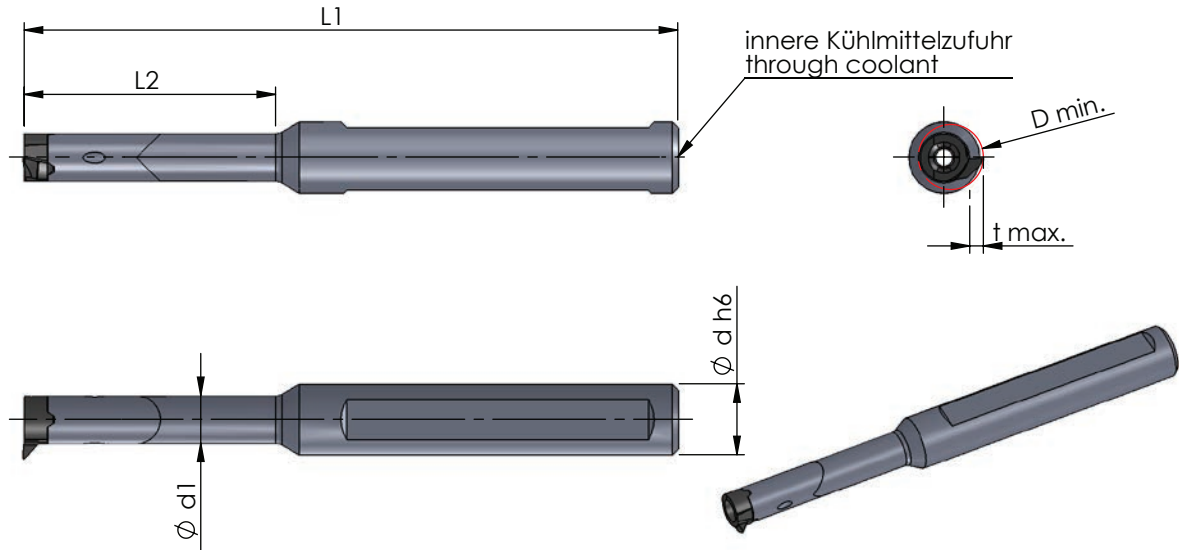

Abmessungen in mm

dimensions in mm

Bestellnummer part number	Ø d h6	Ø d1	L1	L2	Typ: t max. / D min.	Spannschraube screw	Schraubenschlüssel wrench	Anzugs- drehmoment torque	für Schneidplatte use with insert
616.0012.1HM	12	11	130	40	R/L S016: 4.3 / ø16	M5-MC	T20	7.0 Nm	R/L S16 R/L S016
616.0012.2HM	12	11	130	56					
616.0012.3HM	12	11	150	80					
616.0127.1HM	12.7	11	130	40					
616.0127.2HM	12.7	11	130	56					
616.0127.3HM	12.7	11	150	80					
616.0158.1HM	15.875	11	130	40					
616.0158.2HM	15.875	11	130	56					
616.0158.3HM	15.875	11	150	80					
616.0016.1HM	16	11	130	40					
616.0016.2HM	16	11	130	56					
616.0016.3HM	16	11	150	80					

Hinweis:  
Hartmetall-Klemmhalter mit beschädigter  
Schneidplattenaufnahme können durch unseren  
Reparaturservice in stand gesetzt werden.

Bestellbeispiel:  
616.0012.1HM

note:  
carbide-toolholder with damaged seating can be  
repaired by Dümmel.

order-example:  
616.0012.1HM



# MINICUT

Bohrungsbearbeitung

grooving, boring and profiling

## Typ 618

Klemmhalter Hartmetall

D min. 18 mm

toolholder carbide

D min. 18 mm

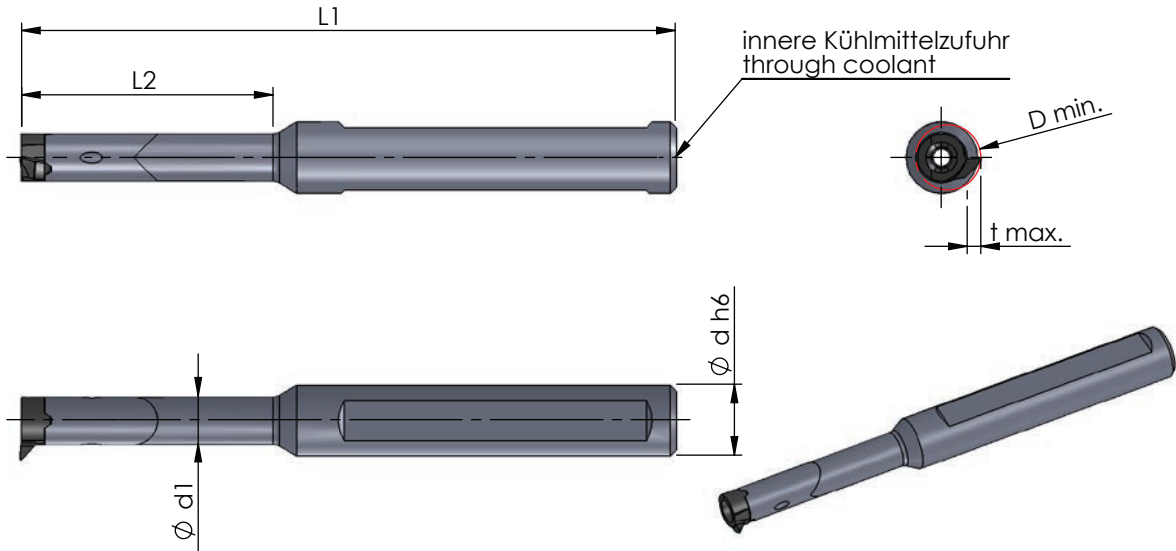

Abmessungen in mm

dimensions in mm

Bestellnummer part number	Ø d h6	Ø d1	L1	L2	Typ: t max. / D min.	Spannschraube screw	Schraubenschlüssel wrench	Anzugs- drehmoment torque	für Schneidplatte use with insert
618.0016.1HM	16	11.5	100	42					
618.0016.2HM	16	11.5	130	60	R/L S18: 6.0 / Ø18				
618.0016.3HM	16	11.5	160	85	R/L S20: 8.0 / Ø20	M5-MC	T20	7.0 Nm	R/L S18 R/L S20
618.0020.3HM	20	11.5	160	85					

Hinweis:  
Hartmetall-Klemmhalter mit beschädigter Schneidplattenaufnahme können durch unseren Reparaturservice instand gesetzt werden.

Bestellbeispiel:  
618.0016.1HM

note:  
carbide-toolholder with damaged seating can be repaired by Dümmel.

order-example:  
618.0016.1HM





# MINICUT

Bohrungsbearbeitung

grooving, boring and profiling

## Typ V08 / V11

Flexohalter V  
Flexible Bearbeitungslänge L1

D min. 8 / 11 mm

Flexo-toolholder V  
Flexible working length L1

D min. 8 / 11 mm

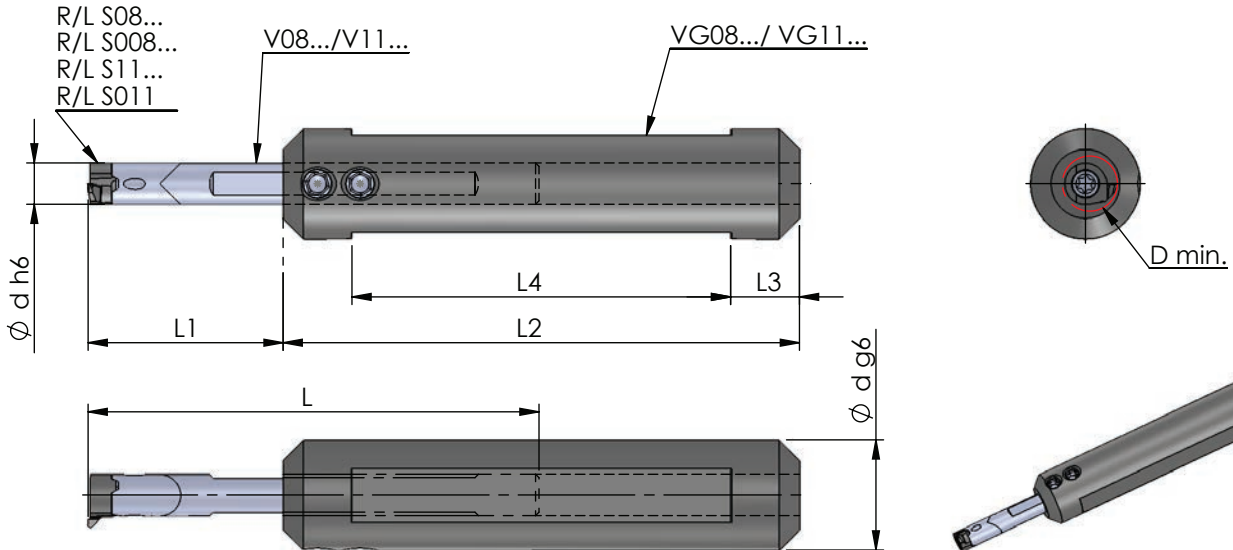

Halter für rechte und linke Schneideinsätze einsetzbar

\* V08... ohne IK!

Abmessungen in mm

toolholder for right and left inserts usable

\* V08... without IK!

dimensions in mm

Bestellnummer part number	D min.	Ø d h6	L	L1 min.	L1 max.	Spannschraube screw	Schraubenschlüssel wrench	Anzugs- drehmoment torque	für Grundhalter for toolholder basic	für Schneidplatte use with insert
V08.0006.2HM *	8	6	65	18	42	M2.6-MC	T8	1.0-1.5 Nm	VG08	R/L S08 / R/L S008
V08.0006.4HM *	8	6	103	40	80					
V11.0008.2HM	11	8	79	20	55	M3.5-MC	T10	2.5-3.0 Nm	VG11	R/L S11 / R/L S011
V11.0008.4HM	11	8	129	50	105					
Bestellnummer part number	D min.	Ø d g6	L2	L3	L4	Spannschraube screw	Schraubenschlüssel wrench		für Halter for holder	
VG08-16	8	16	75	10	55	G016	111.687		V08	
VG08-20	8	20	75	10	55	G016				
VG11-16	11	16	75	10	55	G012		V11		
VG11-20	11	20	75	10	55	G016				

Hinweis:  
Hartmetall-Klemhalter mit beschädigter  
Schneidplattenaufnahme können durch unseren  
Reparaturservice instand gesetzt werden.

Bestellbeispiel:  
V08.0006.2HM

note:  
carbide-toolholder with damaged seating can be  
repaired by Dümmel.

order-example:  
V08.0006.2HM



# MINICUT

Bohrungsbearbeitung

grooving, boring and profiling

## Typ 614.A / 618.A

Klemmhalter Axialbearbeitung

toolholder face grooving

D min. 12 / 14 / 16 / 18 mm

D min. 12 / 14 / 16 / 18 mm



Abbildung: Halter (R)  
Schneideinsatz (R)

Rechter Halter - rechte Platte  
Linker Halter - linke Platte

Abmessungen in mm

drawing: toolholder (R)  
insert (R)

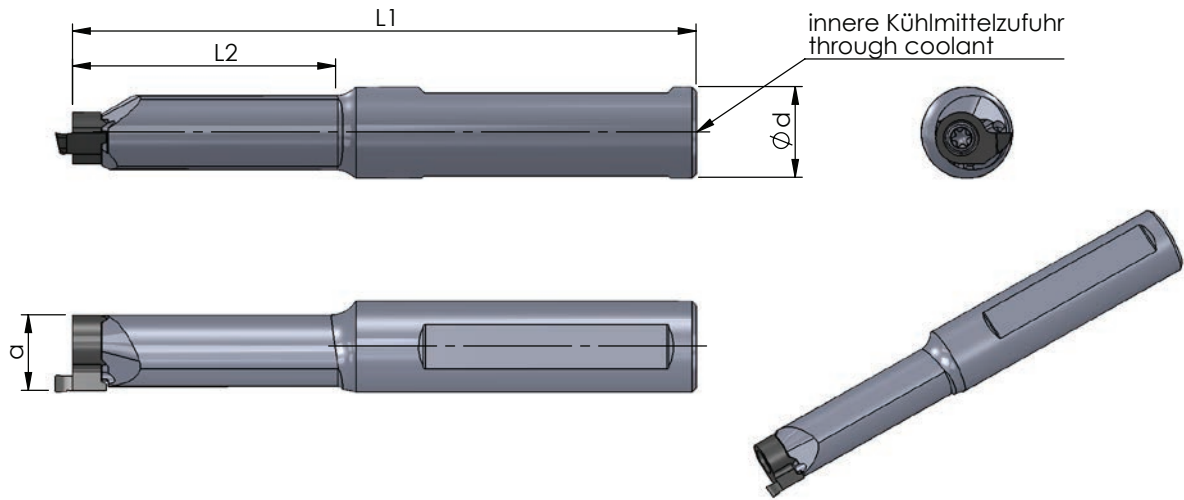
toolholder R - insert R  
toolholder L - insert L

dimensions in mm

Bestellnummer part number	Ø d g6	a	L1	L2	Spannschraube screw	Schraubenschlüssel wrench	Anzugs- drehmoment torque	für Schneidplatte use with insert
R/L 614.A016.3ST	16	13.5	90	25	M4-MC	T15	4.0-4.5 Nm	R/L S014
R/L 614.A016.3E.ST	16	13.5	110	45				
Bestellnummer part number	Ø d h6	a	L1	L2	Spannschraube screw	Schraubenschlüssel wrench	Anzugs- drehmoment torque	für Schneidplatte use with insert
R/L 614.A016.3HM	16	13.5	120	60	M4-MC	T15	4.0-4.5 Nm	R/L S014
Bestellnummer part number	Ø d g6	a	L1	L2	Spannschraube screw	Schraubenschlüssel wrench	Anzugs- drehmoment torque	für Schneidplatte use with insert
R/L 618.A016.3ST	16	16.5/17	90	30	M5-MC	T20	6.0-6.5 Nm	R/L S018

Hinweis:  
Hartmetall-Klemmhalter mit beschädigter  
Schneidplattenaufnahme können durch unseren  
Reparaturservice in stand gesetzt werden.

Bestellbeispiel:  
für rechte Ausführung  
R614.A016.3ST

note:  
carbide-toolholder with damaged seating can be  
repaired by Dümmel.

order example:  
righthand version  
R614.A016.3ST



## MINICUT

Bohrungsbearbeitung

grooving, boring and profiling

## Typ 614.SQ / 618.SQ

Klemhalter Stahl, Quadratschaft,  
Axialbearbeitung

toolholder steel, square shank,  
face grooving

D min. 12 / 14 / 16 / 18 mm

D min. 12 / 14 / 16 / 18 mm



Abbildung: Halter (R)  
Schneideinsatz (L)  
Bitte beachten: Rechter Halter  
wird mit linker Platte bestückt und  
umgekehrt.

Abmessungen in mm

drawing: toolholder (R)  
insert (L)  
Please notice: Use right hand  
toolholder with left hand insert  
and vice versa.

dimensions in mm

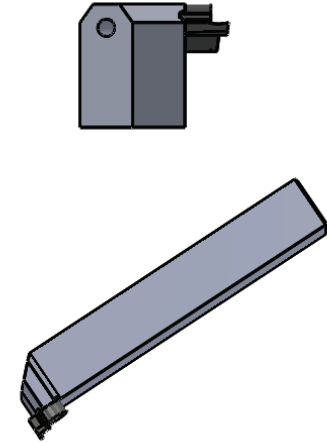
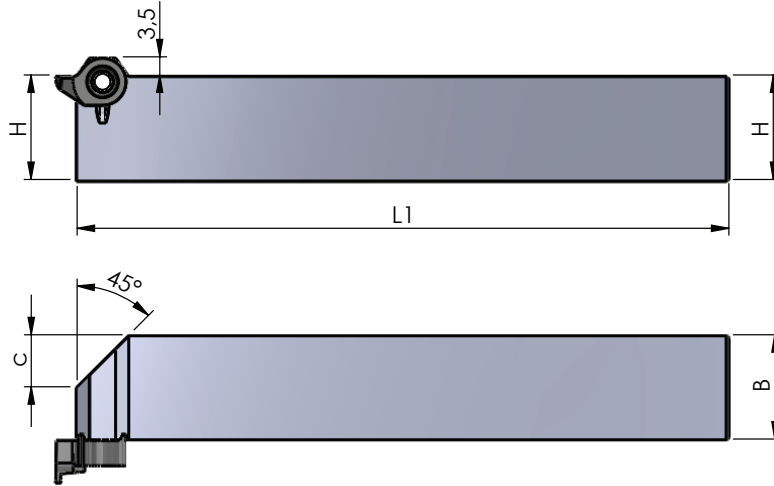
Bestellnummer part number	H	B	L1	c	Spannschraube screw	Schraubenschlüssel wrench	Anzugs- drehmoment torque	für Schneidplatte use with insert
R/L 614.SQ12.ST	12	12	100	2	M4-MC	T15	4.0-4.5 Nm	R/L S014
R/L 614.SQ16.ST	16	16	125	6				
R/L 614.SQ20.ST	20	20	125	10				
R/L 614.SQ25.ST	25	25	150	15				
Bestellnummer part number	H	B	L1	c	Spannschraube screw	Schraubenschlüssel wrench	Anzugs- drehmoment torque	für Schneidplatte use with insert
R/L 618.SQ20.ST	20	20	125	10	M5-MC	T20	6.0-6.5 Nm	R/L S018
R/L 618.SQ25.ST	25	25	150	15				

Bestellbeispiel:  
für rechte Ausführung  
R614.SQ12.ST

order example:  
righthand version  
R614.SQ12.ST

# MINICUT

Bohrungsbearbeitung

grooving, boring and profiling

## Typ 614.SQ.A / 618.SQ.A

Klemhalter Stahl, Quadratschaft, Axialbearbeitung, abgesetzte Version

toolholder steel, square shank, with offset, face grooving

D min. 12 / 14 / 16 / 18 mm

D min. 12 / 14 / 16 / 18 mm



Abbildung: Halter (R)  
Schneideinsatz (L)  
Bitte beachten: Rechter Halter wird mit linker Platte bestückt und umgekehrt.  
Abmessungen in mm

drawing: toolholder (R)  
insert (L)  
Please notice: Use right hand toolholder with left hand insert and vice versa.  
dimensions in mm

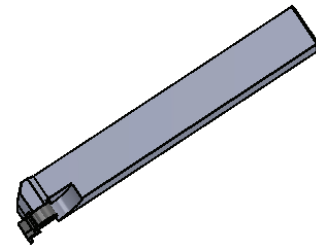
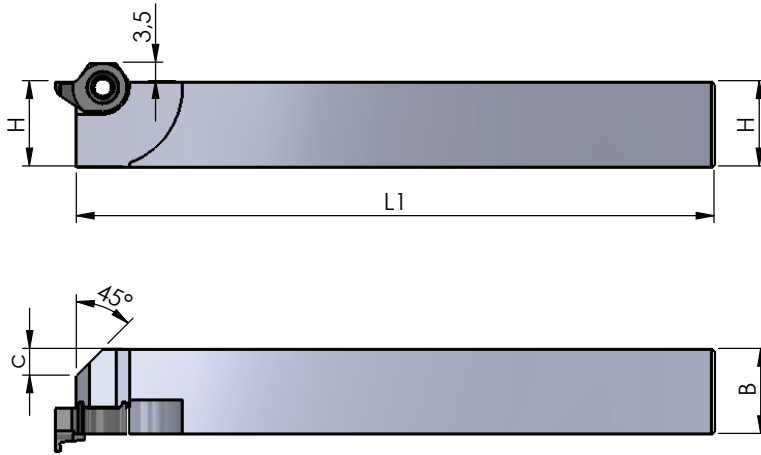

Bestellnummer part number	H	B	L1	c	Spannschraube screw	Schraubenschlüssel wrench	Anzugs- drehmoment torque	für Schneidplatte use with insert
R/L 614.SQ12.ST.A	12	12	100	4	M4-MC	T15	4.0-4.5 Nm	R/L S014
R/L 614.SQ16.ST.A	16	16	120	5				
R/L 614.SQ20.ST.A	20	20	120	5				
R/L 614.SQ25.ST.A	25	25	150	9				
Bestellnummer part number	H	B	L1	c	Spannschraube screw	Schraubenschlüssel wrench	Anzugs- drehmoment torque	für Schneidplatte use with insert
R/L 618.SQ20.ST.A	20	20	120	5	M5-MC	T20	6.0-6.5 Nm	R/L S018
R/L 618.SQ25.ST.A	25	25	150	9				

Bestellbeispiel:  
für rechte Ausführung  
R614.SQ12.ST.A

order example:  
righthand version  
R614.SQ12.ST.A



## MINICUT

Bohrungsbearbeitung

grooving, boring and profiling

## Impressionen

impressions



# MINICUT

Bohrungsbearbeitung

grooving, boring and profiling

# Typ Ausdrehen und Kopieren

allgemein

type boring and profiling,  
general

D min. 7.8 - 15.5 mm

D min. 7.8 - 15.5 mm

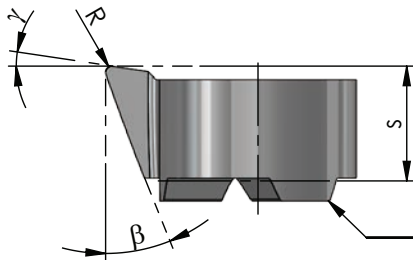
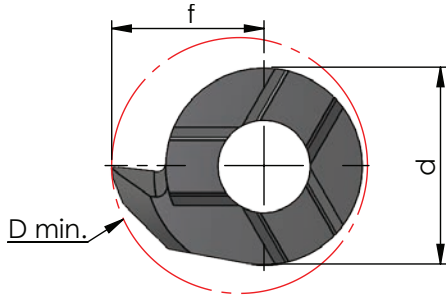

Klemmhalter Stirnseite  
toolholder face

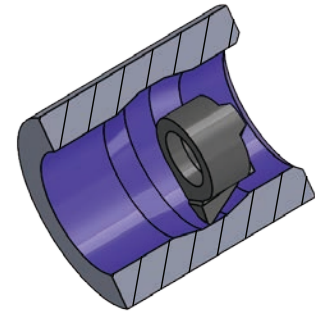

Rechts (R): wie gezeichnet  
Links (L): spiegelbildlich

righthand (R): as shown  
lefthand version (L): mirror image

Abmessungen in mm

dimensions in mm

Bestellnummer part number	$\beta$	$\gamma$	R	f	s	d	Ap max.*	D min.					Klemmhalter Typ toolholder type
									K10F	AL41F	P18C	CBN	
R/L S08.1846.005	18°	8°	0.05	4.65	3.5	6	0.6	7.8	●				
R/L S08.1846.02	18°	8°	0.2	4.65	3.5	6	0.6	7.8	●				608
R/L S08.2046.02	20°	20°	0.2	4.65	3.5	6	0.6	7.8	●				
R/L S09.1855.02	18°	8°	0.2	5.50	3.6	6.2	0.8	9.0	●				609
R/L S09.2055.02	20°	20°	0.2	5.50	3.6	6.2	0.8	9.0	●				
R/L S11.1855.02	18°	8°	0.2	5.50	4.2	8	1.0	9.8	●				
R/L S11.1867.02	18°	8°	0.2	6.70	4.2	8	1.0	11.0	●				611
R/L S11.2067.02	20°	20°	0.2	6.70	4.2	8	1.0	11.0	●				
R/L S14.1867.02	18°	8°	0.2	8.70	5.3	9	1.5	13.8	●				614
R/L S14.2087.02	20°	20°	0.2	8.70	5.3	9	1.5	14.0	●				
R/L S16.1897.02	18°	8°	0.2	9.70	5.4	11	1.5	15.5	●				616

\*Ap max. = max. Schnitttiefe(werkstoffabhängig)

Weitere HM Sorten können Sie in der Sortenübersicht im Kapitel "Technische Hinweise" und der Preisliste finden.

Bestellbeispiel: für rechte Ausführung und Sorte RS08.1846.02/AL41F

\*Ap max. = maximum depth of cut (depending on material)

More carbide grades you can find in the grades summary in the chapter "technical instructions" and in the price list.  
order-example: righthand version and grade RS08.1846.02/AL41F

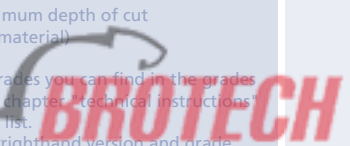

## MINICUT

Bohrungsbearbeitung

grooving, boring and profiling

## Typ Ausdrehen und Kopieren

von gehärteten Teilen mit CBN

D min. 7.8 - 15.5 mm

type boring and profiling,  
of hardened parts with CBN

D min. 7.8 - 15.5 mm

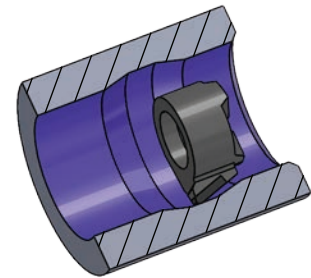
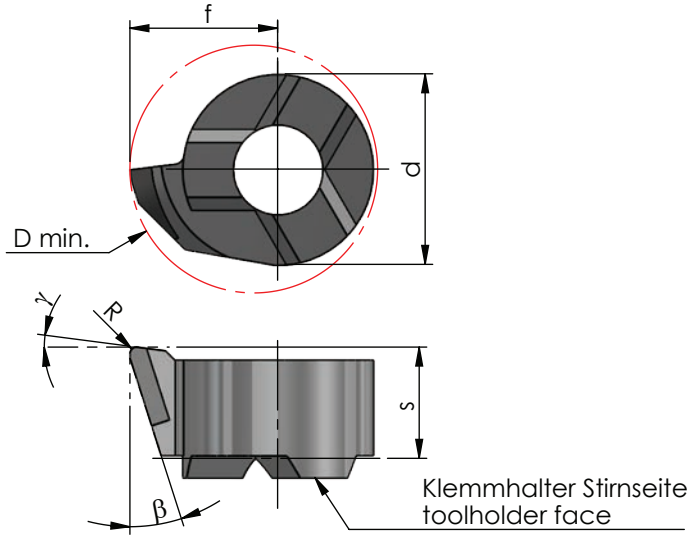

Rechts (R): wie gezeichnet  
Links (L): spiegelbildlich

righthand (R): as shown  
lefthand version (L): mirror image

Abmessungen in mm

dimensions in mm

Bestellnummer part number	$\beta$	$\gamma$	R	f	s	d	D min.					Klemmhalter Typ toolholder type
								K10F	AL41F	CN45F	CBN	
R/L S08.1846.02/CBN	18°	8°	0.2	4.65	3.5	6	7.8				●	608
R/L S11.1867.02/CBN	18°	8°	0.2	6.70	4.1	8	11				●	611
R/L S14.1867.02/CBN	18°	8°	0.2	8.70	5.3	9	14				●	614
R/L S16.1897.02/CBN	18°	8°	0.2	9.70	5.4	11	15.5	●	●	●	●	616

Weitere HM Sorten können Sie in der Sortenübersicht im Kapitel "Technische Hinweise" und der Preisliste finden.

Bestellbeispiel:  
für rechte Ausführung und Sorte CBN  
RS08.1846.02/CBN

More carbide grades you can find in the grades summary in the chapter "technical instructions" and in the price list.

order example:  
righthand version and grade CBN  
RS08.1846.02/CBN

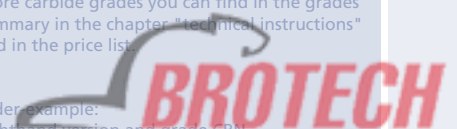

# MINICUT

Bohrungsbearbeitung

grooving, boring and profiling

## Typ Ausdrehen und Kopieren

allgemein,  
Innenfreistriche DIN 509

D min. 7.8 - 20 mm

type boring and profiling,  
general, undercuts DIN 509

D min. 7.8 - 20 mm

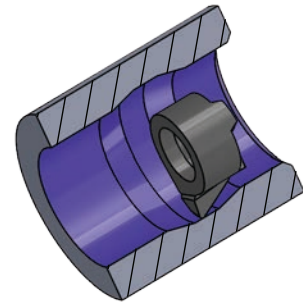
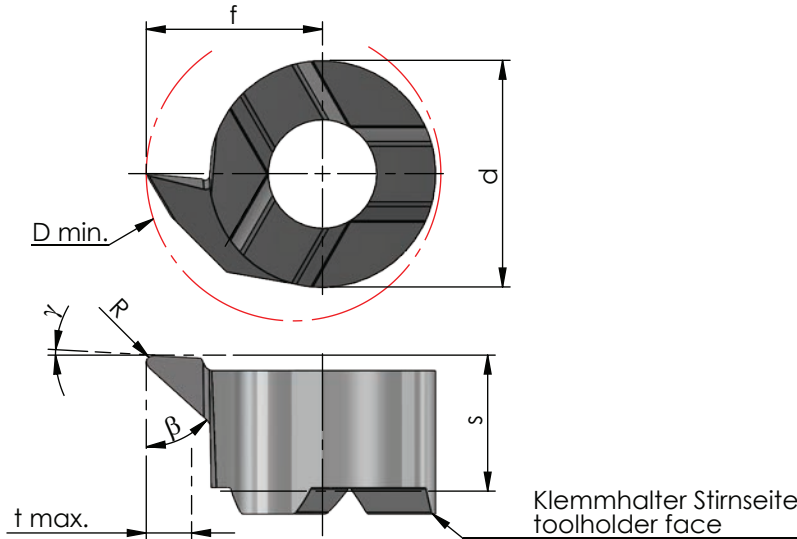

Beispielzeichnung  
exemplary application

Rechts (R): wie gezeichnet  
Links (L): spiegelbildlich

righthand (R): as shown  
lefthand version (L): mirror image

Abmessungen in mm

dimensions in mm

Bestellnummer part number	$\beta$	$\gamma$	R	f	s	d	Ap max.*	t max.	D min.					Klemmhalter Typ toolholder type
										K10F	AL41F	P18C	CBN	
R/L S08.4746.01	47°	3°	0.1	4.65	3.5	6	0.4	1.2	7.8		●			608
R/L S08.4746.02	47°	3°	0.2	4.65	3.5	6	0.4	1.2	7.8		●			608
R/L S09.4755.02	47°	3°	0.2	5.50	3.6	6.2	0.5	1.5	9.0		●			609
R/L S11.4767.02	47°	3°	0.2	6.70	4.2	8	0.6	2.3	11		●			611
R/L S14.4787.02	47°	3°	0.2	8.70	5.3	9	0.8	4.0	13.7		●			614
R/L S14.4787.04	47°	3°	0.4	8.70	5.3	9	0.8	4.0	13.7		●			614
R/L S16.4710.02	47°	3°	0.2	10.2	5.4	11	1.0	4.3	15.8		●			616
R/L S18.4712.02	47°	3°	0.2	12.0	5.6	11	1.0	6.0	18		●			618
R/L S20.4714.02	47°	3°	0.2	14.0	5.6	11	1.2	8.0	20		●			618
R/L S08.2555.02	30°	5°	0.2	4.65	3.5	6	0.4	1.0	7.8	●	●			608
R/L S11.2755.02	30°	5°	0.2	6.70	4.2	8	0.6	2.3	11	●	●			611
R/L S14.3555.02	30°	5°	0.2	8.70	5.3	9	0.8	4.0	13.7		●			614
R/L S16.4055.02	30°	5°	0.2	10.2	5.4	11	0.8	4.3	15.8		●			616

\*Ap max. = max. Schnitttiefe(werkstoffabhängig)

Weitere HM Sorten können Sie in der Sortenübersicht im Kapitel "Technische Hinweise" und der Preisliste finden.

Bestellbeispiel: für rechte Ausführung und Sorte RS08.4746.02/AL41F

\*Ap max. = maximum depth of cut (depending on material)

More carbide grades you can find in the grades summary in the chapter "technical instructions" and in the price list.

order example: righthand version and grade RS08.4746.02/AL41F

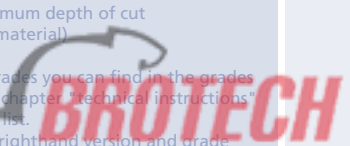



# MINICUT

Bohrungsbearbeitung

grooving, boring and profiling

## Typ Ausdrehen und Kopieren

Ausdrehen mit spezieller Spantreppe

D min. 8 / 9 / 11 mm

type boring and profiling, boring with special chipbreaker

D min. 8 / 9 / 11 mm

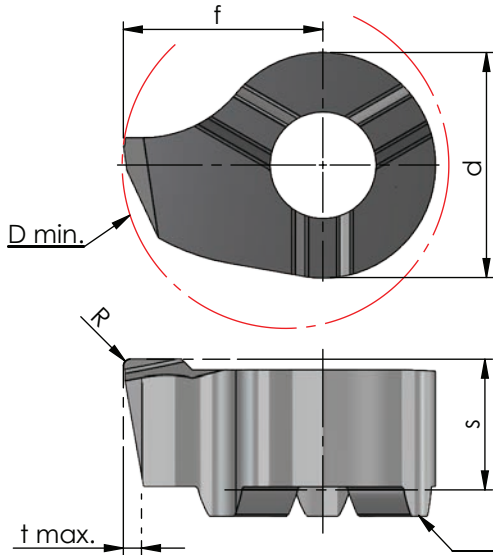

Klemmhalter Stirnseite  
toolholder face

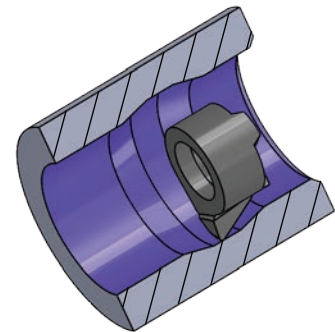

Beispielzeichnung  
exemplary application

Rechts (R): wie gezeichnet  
Links (L): spiegelbildlich

righthand (R): as shown  
lefthand version (L): mirror image

Abmessungen in mm

dimensions in mm

Bestellnummer part number	R	f	s	d	Ap max.*	t max.	D min.	Klemmhalter Typ toolholder type				
								K10F	AL41F	P18C	CBN	
R/L S08.046C.02	0.2	4.65	3.5	6.0	0.4	0.5	8	●				608
R/L S09.055C.02	0.2	5.5	3.6	6.2	0.5	0.5	9	●				609
R/L S11.067C.02	0.2	6.7	4.2	8.0	0.6	0.5	11	●				611

\*Ap max. = max. Schnitttiefe(werkstoffabhängig)

Weitere HM Sorten können Sie in der Sortenübersicht im Kapitel "Technische Hinweise" und der Preisliste finden.

Bestellbeispiel: für rechte Ausführung und Sorte RS09.055C.02/AL41F

\*Ap max. = maximum depth of cut (depending on material)

More carbide grades you can find in the grades summary in the chapter "technical instructions" and in the price list.  
order-example: righthand version and grade RS09.055C.02/AL41F

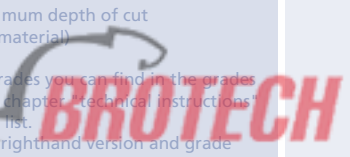

# MINICUT

Bohrungsbearbeitung

grooving, boring and profiling

# Typ Ausdrehen und Kopieren

Rückwärtsdrehen

D min. 7.8 - 13.8 mm

type boring and profiling,  
backboring

D min. 7.8 - 13.8 mm

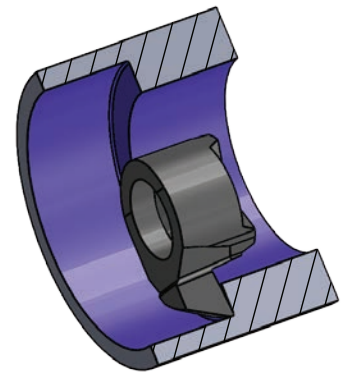
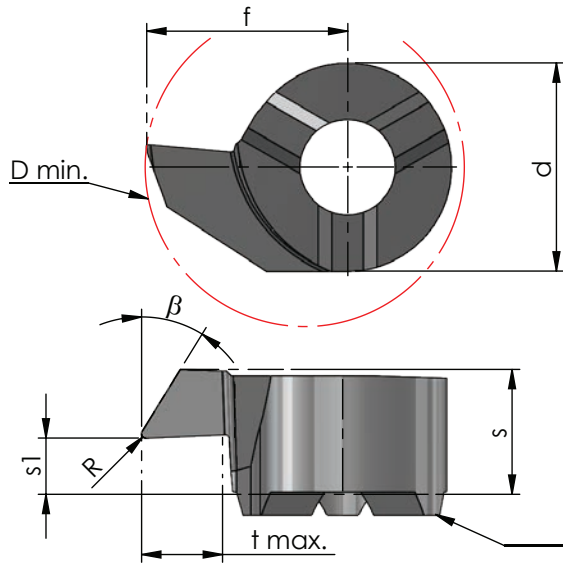

Klemmhalter Stirnseite  
toolholder face

Rechts (R): wie gezeichnet  
Links (L): spiegelbildlich

righthand (R): as shown  
lefthand version (L): mirror image

Abmessungen in mm

dimensions in mm



Bestellnummer part number	$\beta$	R	f	s	s1	d	Ap max.*	t max.	D min.	Klemmhalter Typ toolholder type				
										K10F	AL41F	P18C	CBN	
R/L S08.3046.02	30°	0.2	4.65	3.5	1.0	6	0.6	1.3	7.80	●				608
R/L S09.3055.02	30°	0.2	5.5	3.55	1.2	6.2	0.8	1.7	9.00	●				609
R/L S09.3065.02	30°	0.2	6.5	3.55	1.2	6.2	0.8	2.3	10.0	●				609
R/L S11.3067.02	30°	0.2	6.70	4.3	1.6	8	1.0	2.3	11.0	●				611
R/L S14.3087.02	30°	0.2	8.70	5.4	2.4	9	1.5	3.5	13.8	●				614

\*Ap max. = max. Schnitttiefe(werkstoffabhängig)

Weitere HM Sorten können Sie in der Sortenübersicht im Kapitel "Technische Hinweise" und der Preisliste finden.

Bestellbeispiel: für rechte Ausführung und Sorte RS08.3046.02/AL41F

\*Ap max. = maximum depth of cut (depending on material)

More carbide grades you can find in the grades summary in the chapter "technical instructions" and in the price list.  
order-example:righthand version and grade RS08.3046.02/AL41F

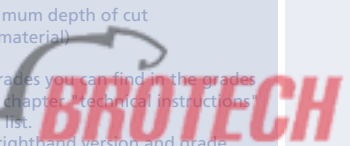

## MINICUT

Bohrungsbearbeitung

grooving, boring and profiling

## Impressionen

impressions

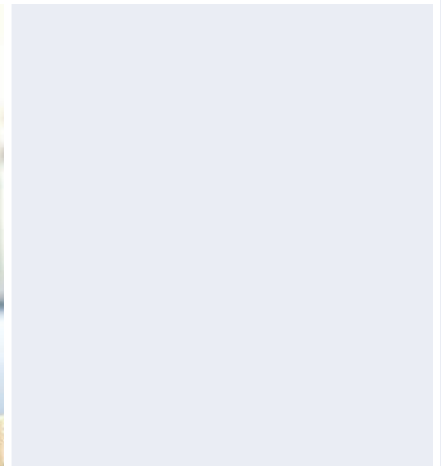
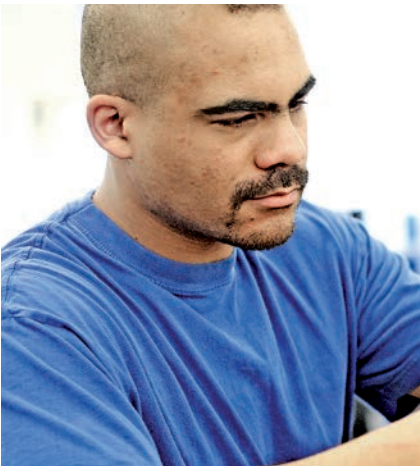
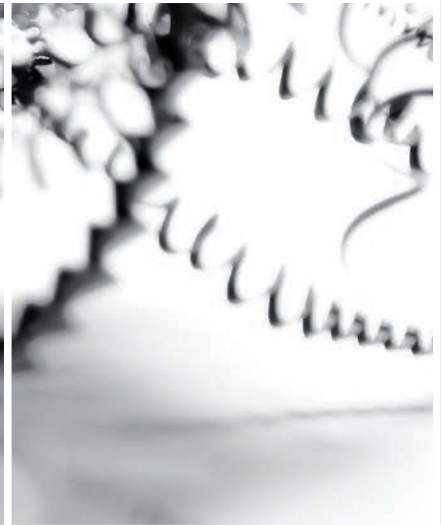
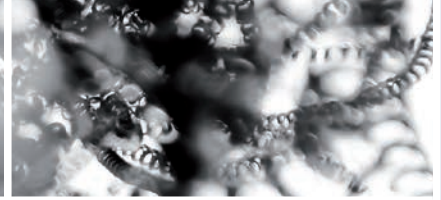
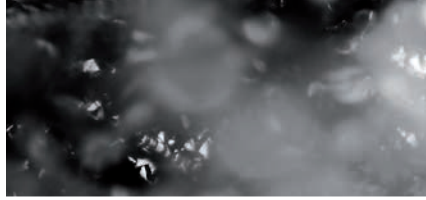

# MINICUT

Bohrungsbearbeitung

grooving, boring and profiling

## Typ Stechdrehen

für Sicherungsringe DIN 471 / 472  
und Stechdrehen allgemein

type grooving,  
for circlips DIN 471 / 472  
and grooving

D min. 8 mm

D min. 8 mm

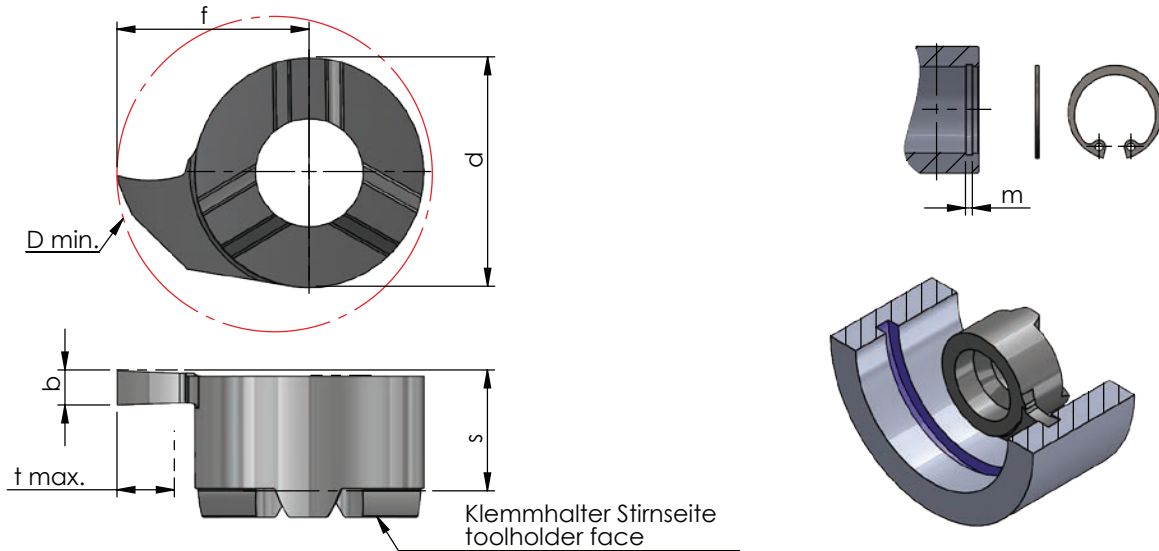

Rechts (R): wie gezeichnet  
Links (L): spiegelbildlich

righthand (R): as shown  
lefthand version (L): mirror image

Abmessungen in mm

dimensions in mm

Bestellnummer part number	Nut-Maß m groove dim. m DIN 471 / DIN 472	b +0.03	b (inch)	f	s	d	t max.	D min.	Material			Klemmhalter Typ toolholder type
									K10F	AL41F	P18C	
R/L S008.0070	0.7	0.73		4.8	3.3	6	1.0	8		●		608
R/L S008.0079	-	0.79	0.031"	4.8	3.3	6	1.0	8		●		
R/L S008.0080	0.8	0.83		4.8	3.3	6	1.0	8		●		
R/L S008.0090	0.9	0.93		4.8	3.3	6	1.0	8		●		
R/L S008.0099	-	0.99	0.039"	4.8	3.3	6	1.0	8		●		
R/L S008.0100	-	1.00		4.8	3.3	6	1.0	8	●	●		
R/L S008.0110	1.1	1.20		4.8	3.3	6	1.0	8	●	●		
R/L S008.0117	-	1.17	0.046"	4.8	3.3	6	1.0	8		●		
R/L S008.0130	1.3	1.40		4.8	3.3	6	1.0	8		●		
R/L S008.0142	-	1.42	0.056"	4.8	3.3	6	1.0	8		●		
R/L S008.0150	-	1.50		4.8	3.3	6	1.0	8		●		
R/L S008.0157	-	1.57	0.062"	4.8	3.3	6	1.0	8		●		
R/L S008.0160	1.6	1.70		4.8	3.3	6	1.0	8		●		
R/L S008.0198	-	1.98	0.078"	4.8	3.3	6	1.0	8		●		
R/L S008.0200	-	2.00		4.8	3.3	6	1.0	8	●	●		

Weitere HM Sorten können Sie in der Sorten-  
übersicht im Kapitel "Technische Hinweise" und  
der Preisliste finden.

Bestellbeispiel:  
für rechte Ausführung und Sorte  
RS008.0070/AL41F

More carbide grades you can find in the grades  
summary in the chapter "technical instructions"  
and in the price list.

order-example:  
righthand version and grade  
RS008.0070/AL41F

## MINICUT

Bohrungsbearbeitung

grooving, boring and profiling

## Typ Stechdrehen

für Sicherungsringe DIN 471 / 472  
und Stechdrehen allgemein

D min. 9 mm

type grooving,  
for circlips DIN 471 / 472  
and grooving

D min. 9 mm

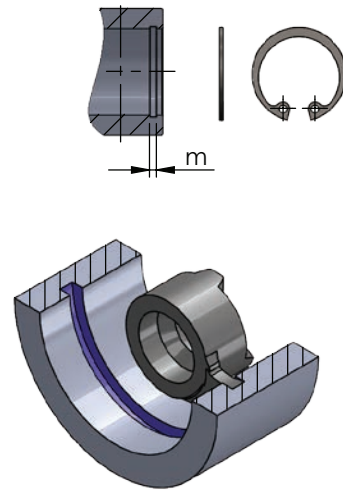
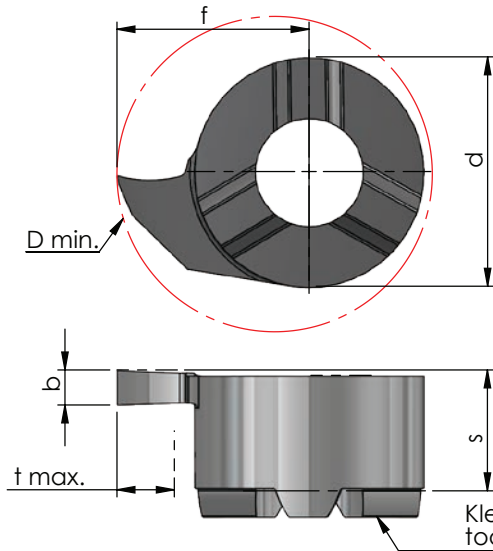

Rechts (R): wie gezeichnet  
Links (L): spiegelbildlich

righthand (R): as shown  
lefthand version (L): mirror image

Abmessungen in mm

dimensions in mm

Bestellnummer part number	Nut-Maß m groove dim. m DIN 471 / DIN 472	b +0.03	f	s	d	t max.	D min.	K10F	AL41F	P18C	Klemmhalter Typ toolholder type
R/L S009.0070	0.7	0.73	5.5	3.6	6.2	1.2	9	●	●	●	609
R/L S009.0080	0.8	0.83	5.5	3.6	6.2	1.3	9	●	●	●	
R/L S009.0090	0.9	0.93	5.5	3.6	6.2	1.5	9	●	●	●	
R/L S009.0100	-	1.00	5.5	3.6	6.2	1.8	9	●	●	●	
R/L S009.0110	1.1	1.20	5.5	3.6	6.2	1.8	9	●	●	●	
R/L S009.0130	1.3	1.40	5.5	3.6	6.2	1.8	9	●	●	●	
R/L S009.0150	-	1.50	5.5	3.6	6.2	1.8	9	●	●	●	
R/L S009.0160	1.6	1.70	5.5	3.6	6.2	1.8	9	●	●	●	
R/L S009.0200	-	2.00	5.5	3.6	6.2	1.8	9	●	●	●	
R/L S009.0250	-	2.50	5.5	3.6	6.2	1.8	9	●	●	●	
R/L S009.0300	-	3.00	5.5	3.6	6.2	1.8	9	●	●	●	

Weitere HM Sorten können Sie in der Sortenübersicht im Kapitel "Technische Hinweise" und der Preisliste finden.

Bestellbeispiel:  
für rechte Ausführung und Sorte  
RS009.0070/AL41F

More carbide grades you can find in the grades summary in the chapter "technical instructions" and in the price list.

order example:  
righthand version and grade  
RS009.0070/AL41F

**BROTECH**

# MINICUT

Bohrungsbearbeitung

grooving, boring and profiling

# Typ Stechdrehen

für Sicherungsringe DIN 471 / 472  
und Stechdrehen allgemein

type grooving,  
for circlips DIN 471 / 472  
and grooving

D min. 11 mm

D min. 11 mm

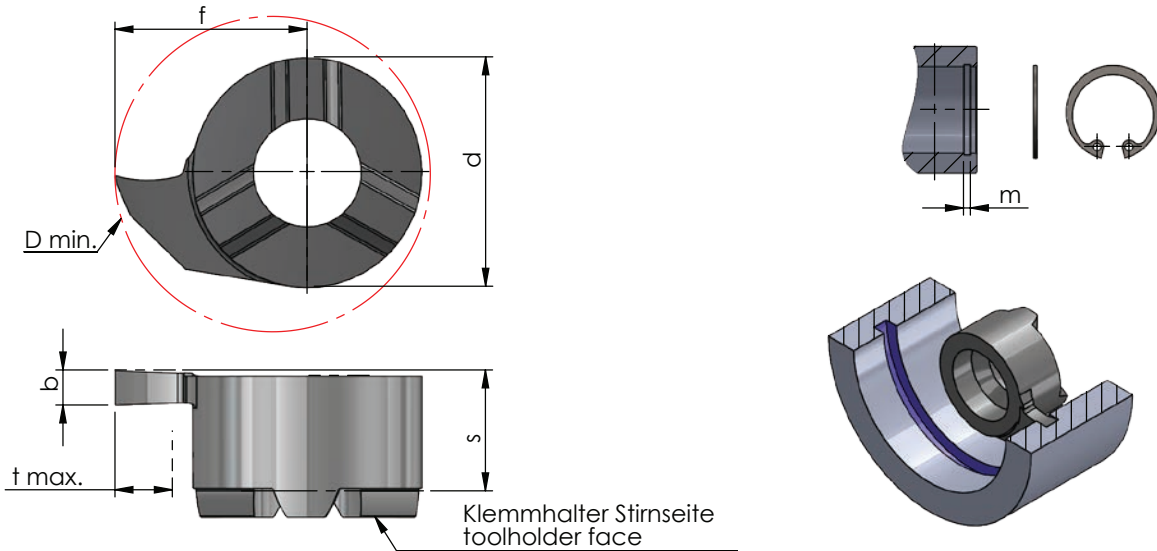

Rechts (R): wie gezeichnet  
Links (L): spiegelbildlich

righthand (R): as shown  
lefthand version (L): mirror image

Abmessungen in mm

dimensions in mm

Bestellnummer part number	Nut-Maß m groove dim. m DIN 471 / DIN 472	b +0.03	b (inch)	f	s	d	t max.	D min.	K10F	AL41F	P18C	Klemmhalter Typ toolholder type
R/L S011.0070	0.7	0.73		6.7	4.2	8	1.2	11	●			611
R/L S011.0080	0.8	0.83		6.7	4.2	8	1.3	11	●			
R/L S011.0090	0.9	0.93		6.7	4.2	8	1.5	11	●			
R/L S011.0099	-	0.99	0.039"	6.7	4.2	8	1.5	11	●			
R/L S011.0100	-	1.00		6.7	4.2	8	2.3	11	●	●		
R/L S011.0110	1.1	1.20		6.7	4.2	8	2.3	11	●	●		
R/L S011.0117	-	1.17	0.046"	6.7	4.2	8	2.3	11	●			
R/L S011.0130	1.3	1.40		6.7	4.2	8	2.3	11	●	●		
R/L S011.0150	-	1.50		6.7	4.2	8	2.3	11	●	●		
R/L S011.0157	-	1.57	0.062"	6.7	4.2	8	2.3	11	●			
R/L S011.0160	1.6	1.70		6.7	4.2	8	2.3	11	●	●		
R/L S011.0200	-	2.00		6.7	4.2	8	2.3	11	●	●		
R/L S011.0238	-	2.38	0.094"	6.7	4.2	8	2.3	11	●			
R/L S011.0250	-	2.50		6.7	4.2	8	2.3	11	●	●		
R/L S011.0300	-	3.00		6.7	4.2	8	2.3	11	●	●		

Weitere HM Sorten können Sie in der Sortenübersicht im Kapitel "Technische Hinweise" und der Preisliste finden.

Bestellbeispiel:  
für rechte Ausführung und Sorte  
RS011.0070/AL41F

More carbide grades you can find in the grades summary in the chapter "technical instructions" and in the price list.

order example:  
righthand version and grade  
RS011.0070/AL41F



## MINICUT

Bohrungsbearbeitung

grooving, boring and profiling

## Typ Stechdrehen

für Sicherungsringe DIN 471 / 472  
und Stechdrehen allgemein

D min. 14 mm

type grooving,  
for circlips DIN 471 / 472  
and grooving

D min. 14 mm

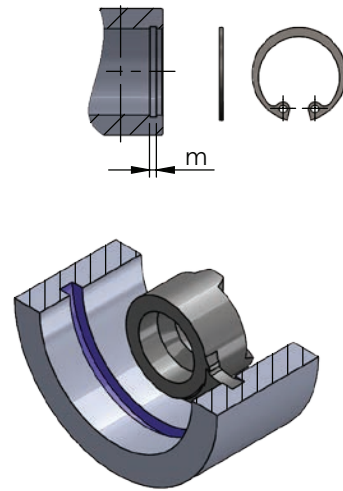
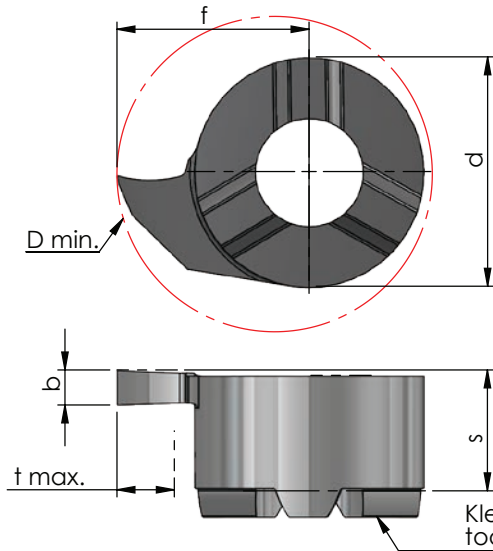

Rechts (R): wie gezeichnet  
Links (L): spiegelbildlich

righthand (R): as shown  
lefthand version (L): mirror image

Abmessungen in mm

dimensions in mm

neu

Bestellnummer part number	Nut-Maß m groove dim. m DIN 471 / DIN 472	b +0.03	b (inch)	f	s	d	t max.	D min.	K10F	AL41F	P18C	Klemmhalter Typ toolholder type
R/L S014.0070	0.7	0.73		9.0	5.2	9	1.2	14	●			614
R/L S014.0080	0.8	0.83		9.0	5.2	9	1.3	14		●		
R/L S014.0090	0.9	0.93		9.0	5.2	9	1.5	14	●	●		
R/L S014.0100	-	1.00		9.0	5.2	9	4.0	14		●		
R/L S014.0110	1.1	1.20		9.0	5.3	9	4.0	14	●	●		
R/L S014.0117	-	1.17	0.046"	9.0	5.3	9	4.0	14		●		
R/L S014.0130	1.3	1.40		9.0	5.3	9	4.0	14		●		
R/L S014.0150	-	1.50		9.0	5.3	9	4.0	14	●	●		
R/L S014.0157	-	1.57	0.062"	9.0	5.3	9	4.0	14		●		
R/L S014.0160	1.6	1.70		9.0	5.3	9	4.0	14	●	●		
R/L S014.0200	-	2.00		9.0	5.3	9	4.0	14	●	●		
R/L S014.0238	-	2.38	0.094"	9.0	5.3	9	4.0	14		●		
R/L S014.0250	-	2.50		9.0	5.3	9	4.0	14	●	●		
R/L S014.0300	-	3.00		9.0	5.3	9	4.0	14	●	●		

Weitere HM Sorten können Sie in der Sortenübersicht im Kapitel "Technische Hinweise" und der Preisliste finden.

Bestellbeispiel:  
für rechte Ausführung und Sorte  
RS014.0070/AL41F

More carbide grades you can find in the grades summary in the chapter "technical instructions" and in the price list.

order-example:  
righthand version and grade  
RS014.0070/AL41F

**BROTECH**

# MINICUT

Bohrungsbearbeitung

grooving, boring and profiling

## Typ Stechdrehen

für Sicherungsringe DIN 471 / 472  
und Stechdrehen allgemein

D min. 16 mm

type grooving,  
for circlips DIN 471 / 472  
and grooving

D min. 16 mm

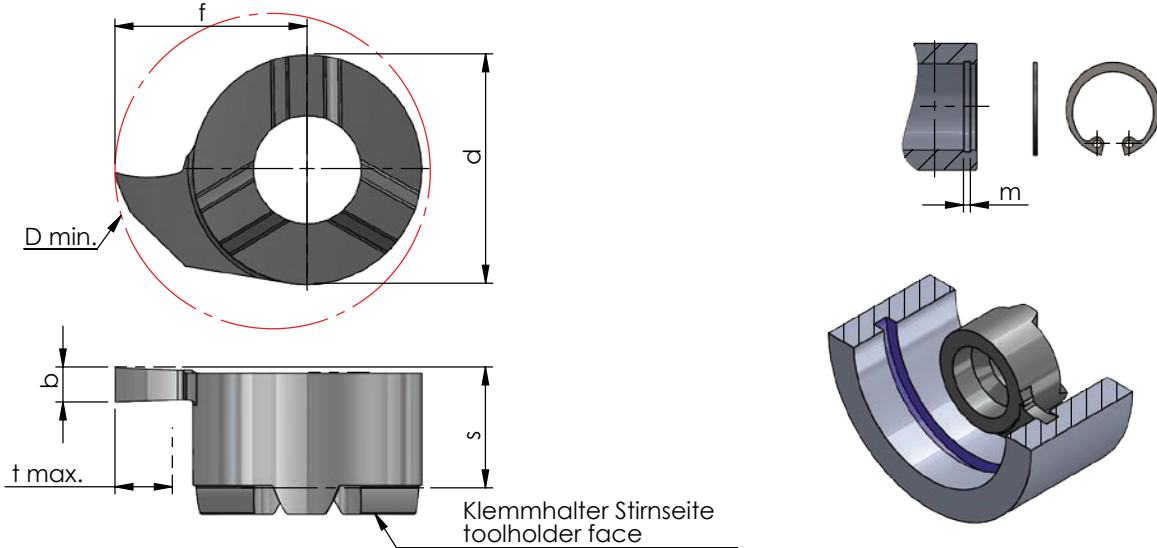

Rechts (R): wie gezeichnet  
Links (L): spiegelbildlich

righthand (R): as shown  
lefthand version (L): mirror image

Abmessungen in mm

dimensions in mm



Bestellnummer part number	Nut-Maß m groove dim. m DIN 471 / DIN 472	b +0.03	b (inch)	f	s	d	t max.	D min.	Material			Klemmhalter Typ toolholder type
									K10F	AL41F	P18C	
R/L S016.0070	0.7	0.73		10.2	5.2	11	1.2	16		●		616
R/L S016.0080	0.8	0.83		10.2	5.2	11	1.3	16		●		
R/L S016.0090	0.9	0.93		10.2	5.2	11	1.5	16		●		
R/L S016.0110	1.1	1.20		10.2	5.4	11	4.3	16	●	●		
R/L S016.0117	-	1.17	0.046"	10.2	5.4	11	4.3	16		●		
R/L S016.0130	1.3	1.40		10.2	5.4	11	4.3	16	●	●		
R/L S016.0150	-	1.50		10.2	5.4	11	4.3	16	●	●		
R/L S016.0157	-	1.57	0.062"	10.2	5.4	11	4.3	16		●		
R/L S016.0160	1.6	1.70		10.2	5.4	11	4.3	16	●	●		
R/L S016.0200	-	2.00		10.2	5.4	11	4.3	16	●	●		
R/L S016.0238	-	2.38	0.094"	10.2	5.4	11	4.3	16		●		
R/L S016.0250	-	2.50		10.2	5.4	11	4.3	16	●	●		
R/L S016.0300	-	3.00		10.2	5.4	11	4.3	16	●	●		
R/L S016.0350	-	3.50		10.2	5.4	11	4.3	16		●		
R/L S016.0400	-	4.00		10.2	5.4	11	4.3	16		●		

Weitere HM Sorten können Sie in der Sortenübersicht im Kapitel "Technische Hinweise" und der Preisliste finden.

Bestellbeispiel:  
für rechte Ausführung und Sorte  
RS016.0070/AL41F

More carbide grades you can find in the grades summary in the chapter "technical instructions" and in the price list.

order example:  
righthand version and grade  
RS016.0070/AL41F





## MINICUT

Bohrungsbearbeitung

grooving, boring and profiling

## Typ Stechdrehen

Stechdrehen allgemein

type grooving,  
general use

D min. 18 / 20 mm

D min. 18 / 20 mm

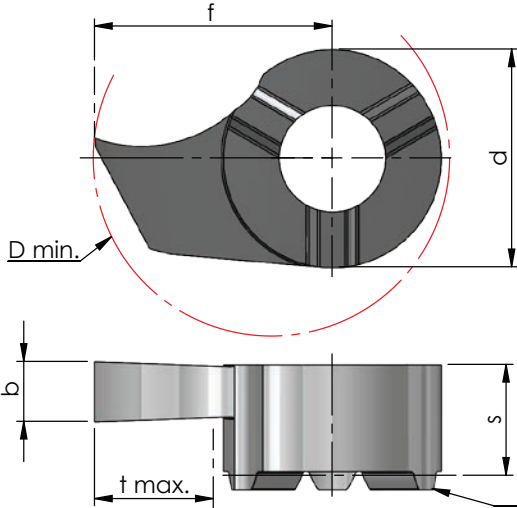

Klemmhalter Stirnseite  
toolholder face

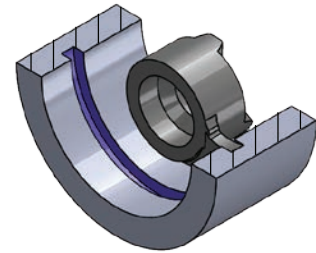

Beispielzeichnung  
exemplary application

Rechts (R): wie gezeichnet  
Links (L): spiegelbildlich

righthand (R): as shown  
lefthand version (L): mirror image

Abmessungen in mm

dimensions in mm

Bestellnummer part number	b +0.03	f	s	d	t max.	D min.				Klemmhalter Typ toolholder type
							K10F	AL41F	P18C	
R/L S18.0150.00	1.5	12	5.6	11	6.0	18	●	●	●	618
R/L S18.0200.00	2.0	12	5.6	11	6.0	18	●	●	●	
R/L S18.0250.00	2.5	12	5.6	11	6.0	18	●	●	●	
R/L S18.0300.00	3.0	12	5.6	11	6.0	18	●	●	●	
R/L S18.0350.00	3.5	12	5.6	11	6.0	18	●	●	●	
R/L S18.0400.00	4.0	12	5.6	11	6.0	18	●	●	●	
R/L S20.0150.00	1.5	14	5.6	11	8.0	20	●	●	●	
R/L S20.0200.00	2.0	14	5.6	11	8.0	20	●	●	●	
R/L S20.0250.00	2.5	14	5.6	11	8.0	20	●	●	●	
R/L S20.0300.00	3.0	14	5.6	11	8.0	20	●	●	●	
R/L S20.0350.00	3.5	14	5.6	11	8.0	20	●	●	●	
R/L S20.0400.00	4.0	14	5.6	11	8.0	20	●	●	●	

Weitere HM Sorten können Sie in der Sortenübersicht im Kapitel "Technische Hinweise" und der Preisliste finden.

Bestellbeispiel:  
für rechte Ausführung und Sorte  
RS20.0150.00/AL41F

More carbide grades you can find in the grades summary in the chapter "technical instructions" and in the price list.

order example:  
righthand version and grade  
RS20.0150.00/AL41F

**BROTECH**

# MINICUT

Bohrungsbearbeitung

grooving, boring and profiling

## Typ Stechdrehen

Stechdrehen allgemein,  
große Einstechtiefe

D min. 16 / 17 mm

type grooving, general use,  
maximum depth of groove

D min. 16 / 17 mm

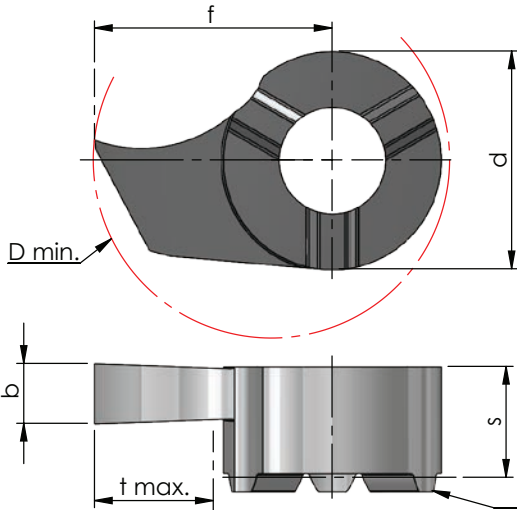

Klemmhalter Stirnseite  
toolholder face

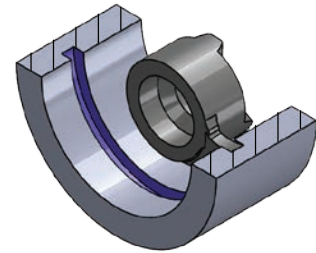

Beispielzeichnung  
exemplary application

Rechts (R): wie gezeichnet  
Links (L): spiegelbildlich

righthand (R): as shown  
lefthand version (L): mirror image

Abmessungen in mm

dimensions in mm

Bestellnummer part number	b +0.03	f	s	d	t max.	D min.	Klemmhalter Typ toolholder type		
							K10F	AL41F	P18C
R/L S55.150.00	1.5	10.5	5.0	9	5.5	16		●	
R/L S55.200.00	2.0	10.5	5.2	9	5.5	16	●	●	
R/L S55.250.00	2.5	10.5	5.2	9	5.5	16		●	
R/L S55.300.00	3.0	10.5	5.2	9	5.5	16		●	
R/L S65.150.00	1.5	11.5	5.0	9	6.5	17		●	
R/L S65.200.00	2.0	11.5	5.2	9	6.5	17		●	
R/L S65.250.00	2.5	11.5	5.2	9	6.5	17		●	
R/L S65.300.00	3.0	11.5	5.2	9	6.5	17		●	

Weitere HM Sorten können Sie in der Sortenübersicht im Kapitel "Technische Hinweise" und der Preisliste finden.

Bestellbeispiel:  
für rechte Ausführung und Sorte  
RS55.150.00/AL41F

More carbide grades you can find in the grades summary in the chapter "technical instructions" and in the price list.

order example:  
righthand version and grade  
RS55.150.00/AL41F

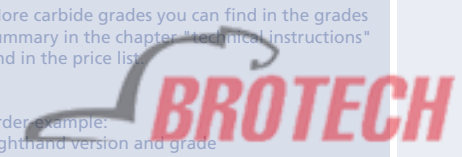

## MINICUT

Bohrungsbearbeitung

grooving, boring and profiling

## Typ Stechdrehen

NC-Feindrehen

D min. 8 - 16 mm

type grooving,  
NC-profiling

D min. 8 - 16 mm

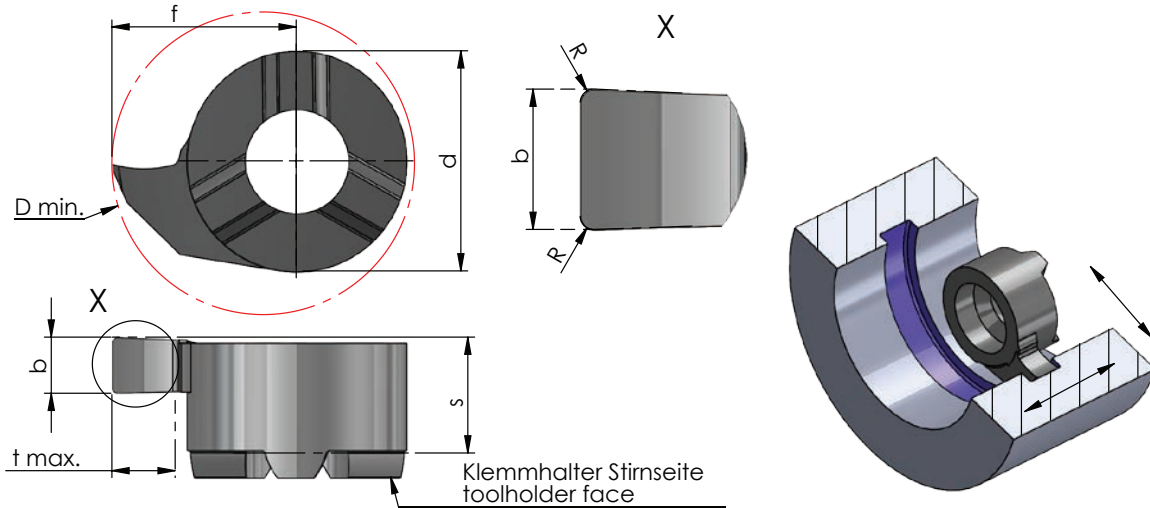

Rechts (R): wie gezeichnet  
Links (L): spiegelbildlich

righthand (R): as shown  
lefthand version (L): mirror image

Abmessungen in mm

dimensions in mm

Bestellnummer part number	b +0.03	b (inch)	R	f	s	d	Ap max.*	t max.	D min.				Klemhalter Typ toolholder type
										K10F	AL41F	P18C	
R/L S08.079.02	0.79	0.031"	0.2	4.8	3.3	6	0.2	1.0	8		●		608
R/L S08.117.02	1.17	0.046"	0.2	4.8	3.3	6	0.2	1.0	8		●		
R/L S08.150.02	1.50		0.2	4.8	3.3	6	0.2	1.0	8	●	●		
R/L S08.157.02	1.57	0.062"	0.2	4.8	3.3	6	0.2	1.0	8		●		
R/L S08.198.02	1.98	0.078"	0.2	4.8	3.3	6	0.2	1.0	8		●		
R/L S08.200.02	2.00		0.2	4.8	3.3	6	0.2	1.0	8	●	●		
R/L S09.150.02	1.50		0.2	5.5	3.6	6.2	0.2	1.8	9		●		609
R/L S09.200.02	2.00		0.2	5.5	3.6	6.2	0.2	1.8	9		●		
R/L S09.150.02.10	1.50		0.2	6.5	3.6	6.2	0.2	2.8	10		●		
R/L S09.200.02.10	2.00		0.2	6.5	3.6	6.2	0.2	2.8	10		●		
↳ ...													

\*Ap max. = max. Schnitttiefe(werkstoffabhängig)

Weitere HM Sorten können Sie in der Sortenübersicht im Kapitel "Technische Hinweise" und der Preisliste finden.

Bestellbeispiel: für rechte Ausführung und Sorte RS08.079.02/AL41F

\*Ap max. = maximum depth of cut (depending on material)

More carbide grades you can find in the grades summary in the chapter "technical instructions" and in the price list.  
order example: righthand version and grade RS08.079.02/AL41F

**PROTECH**

# MINICUT

Bohrungsbearbeitung

grooving, boring and profiling

# Typ Stechdrehen

NC-Feindrehen

type grooving,  
NC-profiling

D min. 8 - 16 mm

D min. 8 - 16 mm

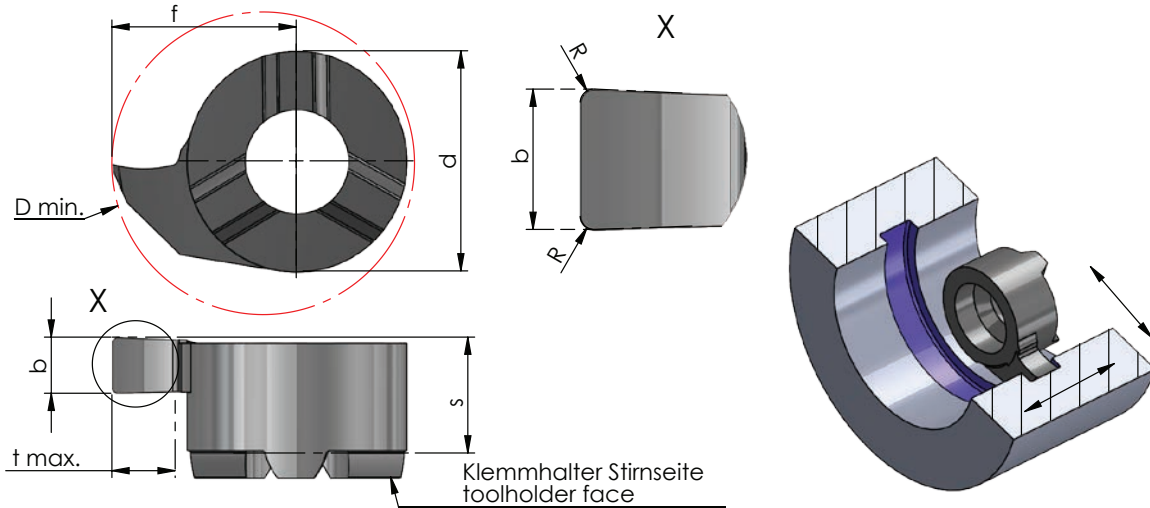

Rechts (R): wie gezeichnet  
Links (L): spiegelbildlich

righthand (R): as shown  
lefthand version (L): mirror image

Abmessungen in mm

dimensions in mm

neu

Bestellnummer part number	b +0.03	b (inch)	R	f	s	d	Ap max.*	t max.	D min.	K10F	AL41F	P18C	Klemhalter Typ toolholder type
⋮ ↙													
R/L S11.079.02	0.78	0.031"	0.2	6.7	4.2	8	0.2	2.3	11		●		611
R/L S11.100.02	1.00		0.2	6.7	4.2	8	0.2	2.3	11		●		
R/L S11.117.02	1.17	0.046"	0.2	6.7	4.2	8	0.2	2.3	11		●		
R/L S11.150.02	1.50		0.2	6.7	4.2	8	0.2	2.3	11	●	●		
R/L S11.157.02	1.57	0.062"	0.2	6.7	4.2	8	0.2	2.3	11		●		
R/L S11.198.02	1.98	0.078"	0.2	6.7	4.2	8	0.2	2.3	11		●		
R/L S11.200.02	2.00		0.2	6.7	4.2	8	0.2	2.3	11	●	●		
R/L S11.238.02	2.38	0.094"	0.2	6.7	4.2	8	0.2	2.3	11		●		
R/L S11.318.02	3.18	0.125"	0.2	6.7	4.2	8	0.2	2.3	11		●		
↳ ...													

\*Ap max. = max. Schnitttiefe(werkstoffabhängig)

Weitere HM Sorten können Sie in der Sortenübersicht im Kapitel "Technische Hinweise" und der Preisliste finden.

Bestellbeispiel: für rechte Ausführung und Sorte RS11.079.02/AL41F

\*Ap max. = maximum depth of cut (depending on material)

More carbide grades you can find in the grades summary in the chapter "technical instructions" and in the price list.

order example: righthand version and grade RS11.079.02/AL41F

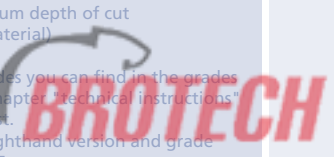

## MINICUT

Bohrungsbearbeitung

grooving, boring and profiling

## Typ Stechdrehen

NC-Feindrehen

D min. 8 - 16 mm

type grooving,  
NC-profiling

D min. 8 - 16 mm

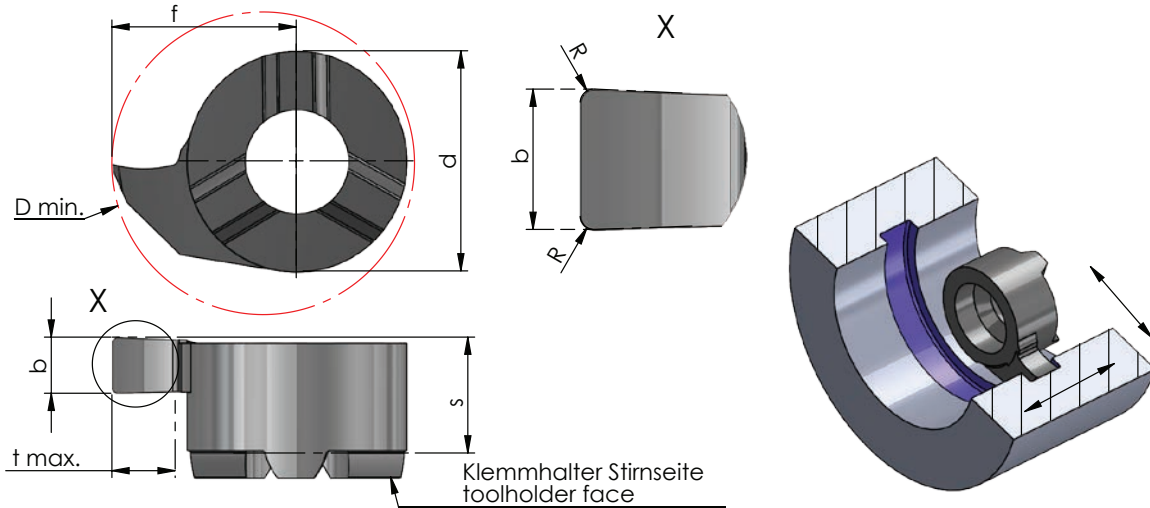

Rechts (R): wie gezeichnet  
Links (L): spiegelbildlich

righthand (R): as shown  
lefthand version (L): mirror image

Abmessungen in mm

dimensions in mm

Bestellnummer part number	b +0.03	b (inch)	R	f	s	d	Ap max.*	t max.	D min.				Klemmhalter Typ toolholder type
										K10F	AL41F	P18C	
⋮ ↙													
R/L S14.150.02	1.50		0.2	9.0	5.3	9	0.2	4.0	14	●	●		614
R/L S14.157.02	1.57	0.062"	0.2	9.0	5.3	9	0.2	4.0	14		●		
R/L S14.157.04	1.57	0.062"	0.4	9.0	5.3	9	0.2	4.0	14		●		
R/L S14.200.02	2.00		0.2	9.0	5.3	9	0.2	4.0	14	●	●		
R/L S14.238.02	2.38	0.094"	0.2	9.0	5.3	9	0.2	4.0	14		●		
R/L S14.318.02	3.18	0.125"	0.2	9.0	5.3	9	0.2	4.0	14		●		
R/L S16.157.02	1.57	0.062"	0.2	10.2	5.4	11	0.2	4.3	16		●		616
R/L S16.200.02	2.00		0.2	10.2	5.4	11	0.2	4.3	16		●		
R/L S16.318.02	3.18	0.125"	0.2	10.2	5.4	11	0.2	4.3	16		●		

\*Ap max. = max. Schnitttiefe(werkstoffabhängig)

Weitere HM Sorten können Sie in der Sortenübersicht im Kapitel "Technische Hinweise" und der Preisliste finden.

Bestellbeispiel: für rechte Ausführung und Sorte RS14.150.02/AL41F

\*Ap max. = maximum depth of cut (depending on material)

More carbide grades you can find in the grades summary in the chapter "technical instructions" and in the price list.  
order example: righthand version and grade RS14.150.02/AL41F

# MINICUT

Bohrungsbearbeitung

grooving, boring and profiling

# Typ Stechdrehen

NC-Feindrehen,  
große Einstechtiefe

D min. 16 / 17 mm

type grooving,  
NC-profiling,  
maximum depth of groove

D min. 16 / 17 mm

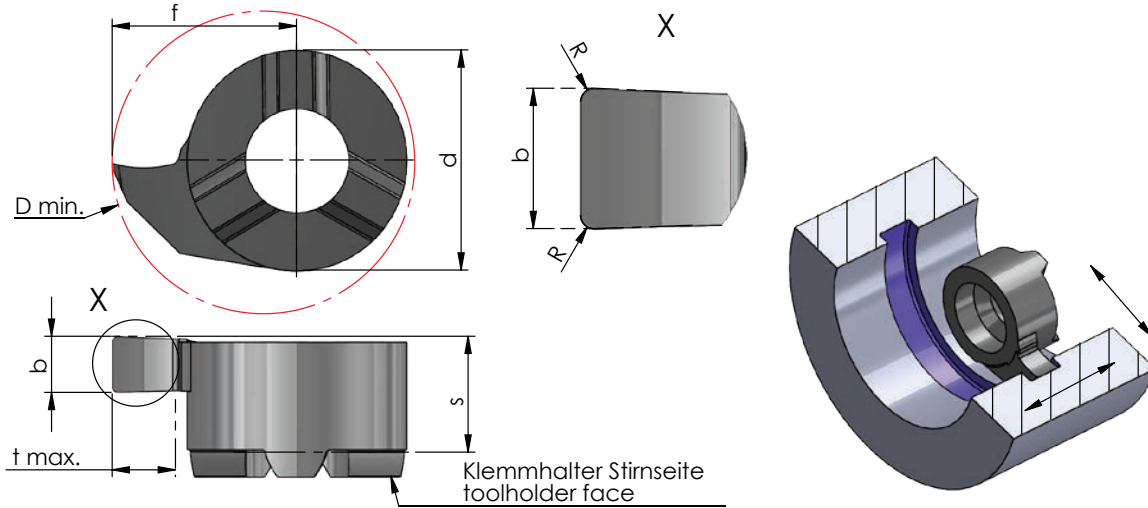

Rechts (R): wie gezeichnet  
Links (L): spiegelbildlich

righthand (R): as shown  
lefthand version (L): mirror image

Abmessungen in mm

dimensions in mm



Bestellnummer part number	b +0.03	R	f	s	d	t max.	D min.				Klemhalter Typ toolholder type
								K10F	AL41F	P18C	
R/L S55.150.02	1.5	0.2	10.5	5.2	9	5.5	16		●		614
R/L S55.200.02	2.0	0.2	10.5	5.2	9	5.5	16		●		
R/L S55.250.02	2.5	0.2	10.5	5.2	9	5.5	16		●		
R/L S55.300.02	3.0	0.2	10.5	5.2	9	5.5	16		●		
R/L S65.150.02	1.5	0.2	11.5	5.2	9	6.5	17		●		
R/L S65.200.02	2.0	0.2	11.5	5.2	9	6.5	17		●		
R/L S65.250.02	2.5	0.2	11.5	5.2	9	6.5	17		●		
R/L S65.300.02	3.0	0.2	11.5	5.2	9	6.5	17	●	●		

Weitere HM Sorten können Sie in der Sortenübersicht im Kapitel "Technische Hinweise" und der Preisliste finden.

Bestellbeispiel:  
für rechte Ausführung und Sorte  
RS55.150.02/AL41F

More carbide grades you can find in the grades summary in the chapter "technical instructions" and in the price list.

order example:  
righthand version and grade  
RS55.150.02/AL41F



## MINICUT

Bohrungsbearbeitung

grooving, boring and profiling

## Typ Stechdrehen

Stechdrehen und Kopieren  
Vollradius

type grooving,  
grooving and profiling  
full radius

D min. 8 - 16 mm  
Vollradius R 0.4 - 2.0

D min. 8 - 16 mm  
full radius R 0.4 - 2.0

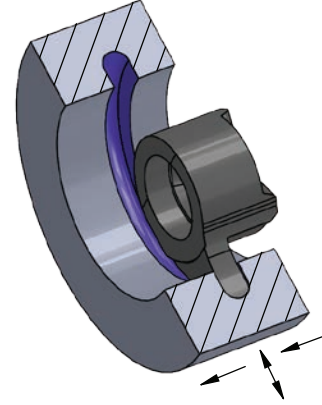
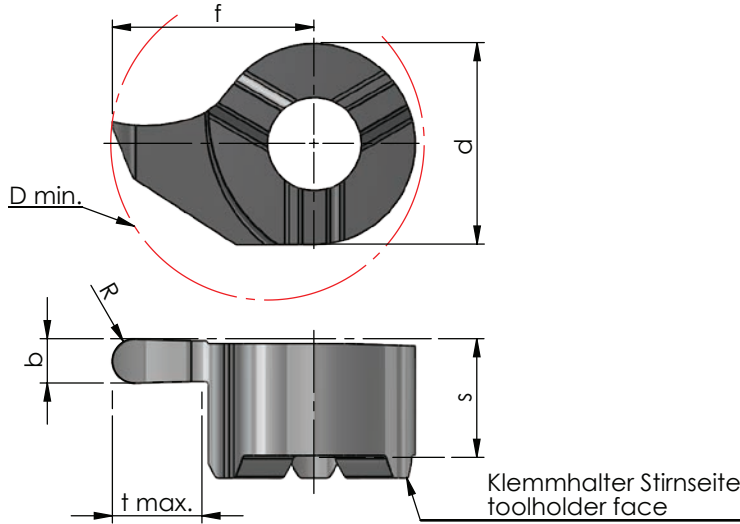

Rechts (R): wie gezeichnet  
Links (L): spiegelbildlich

righthand (R): as shown  
lefthand version (L): mirror image

Abmessungen in mm

dimensions in mm

Bestellnummer part number	b +0.05	b (inch)	R	f	s	d	t max.	D min.				Klemmhalter Typ toolholder type
									K10F	AL41F	P18C	
R/L S08.008R04	0.80		0.40	4.8	3.3	6.0	1.0	8	●	●		608
R/L S08.012R06	1.20		0.60	4.8	3.3	6.0	1.0	8		●		
R/L S08.U15R08	1.57	0.062"	0.78	4.8	3.3	6.0	1.0	8		●		
R/L S08.018R09	1.80		0.90	4.8	3.3	6.0	1.0	8	●	●		
R/L S08.020R10	2.00		1.00	4.8	3.3	6.0	1.0	8		●		
R/L S09.008R04	0.80		0.40	5.5	3.5	6.2	1.6	9		●		609
R/L S09.012R06	1.20		0.60	5.5	3.5	6.2	1.6	9		●		
R/L S09.018R09	1.80		0.90	5.5	3.5	6.2	1.6	9		●		
R/L S09.020R10	2.00		1.00	5.5	3.5	6.2	1.6	9		●		
↳ ...												

Weitere HM Sorten können Sie in der Sortenübersicht im Kapitel "Technische Hinweise" und der Preisliste finden.

Bestellbeispiel:  
für rechte Ausführung und Sorte  
RS08.008R04/AL41F

More carbide grades you can find in the grades summary in the chapter "technical instructions" and in the price list.

order-example:  
righthand version and grade  
RS08.008R04/AL41F

**BROTECH**

# MINICUT

Bohrungsbearbeitung

grooving, boring and profiling

## Typ Stechdrehen

Stechdrehen und Kopieren  
Vollradius

type grooving,  
grooving and profiling  
full radius

D min. 8 - 16 mm  
Vollradius R 0.4 - 2.0

D min. 8 - 16 mm  
full radius R 0.4 - 2.0

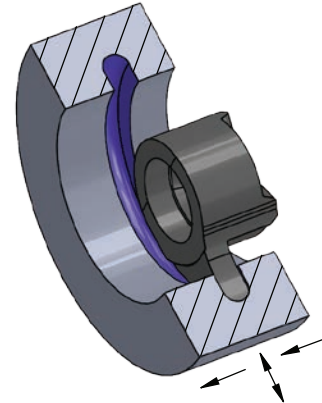
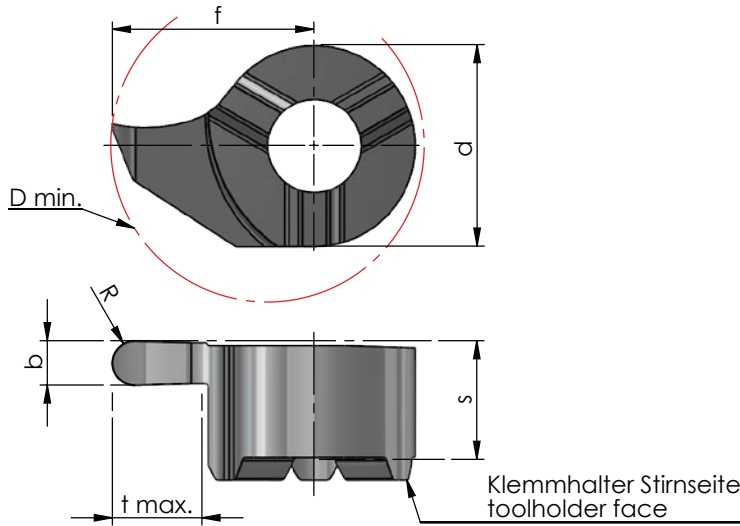

Rechts (R): wie gezeichnet  
Links (L): spiegelbildlich

righthand (R): as shown  
lefthand version (L): mirror image

Abmessungen in mm

dimensions in mm



Bestellnummer part number	b +0.05	b (inch)	R	f	s	d	t max.	D min.				Klemmhalter Typ toolholder type
									K10F	AL41F	P18C	
↙												
R/L S11.008R04	0.80		0.40	6.7	4.2	8	2.3	11	●	●		611
R/L S11.012R06	1.20		0.60	6.7	4.2	8	2.3	11	●	●		
R/L S11.016R08	1.60		0.80	6.7	4.2	8	2.3	11		●		
R/L S11.018R09	1.80		0.90	6.7	4.2	8	2.3	11		●		
R/L S11.020R10	2.00		1.00	6.7	4.2	8	2.3	11	●	●		
R/L S11.024R12	2.40		1.20	6.7	4.2	8	2.3	11		●		
R/L S11.030R15	3.00		1.50	6.7	4.2	8	2.3	11	●	●		
R/L S14.008R04	0.80		0.40	9.0	5.2	9	4.0	14		●		614
R/L S14.012R06	1.20		0.60	9.0	5.3	9	4.0	14		●		
R/L S14.U15R08	1.57	0.062"	0.78	9.0	5.3	9	4.0	14		●		
R/L S14.018R09	1.80		0.90	9.0	5.3	9	4.0	14		●		
R/L S14.020R10	2.00		1.00	9.0	5.3	9	4.0	14		●		
R/L S14.022R11	2.20		1.10	9.0	5.3	9	4.0	14		●		
R/L S14.030R15	3.00		1.50	9.0	5.3	9	4.0	14	●	●		
↘												

Weitere HM Sorten können Sie in der Sortenübersicht im Kapitel "Technische Hinweise" und der Preisliste finden.

Bestellbeispiel:  
für rechte Ausführung und Sorte  
RS11.008R04/AL41F

More carbide grades you can find in the grades summary in the chapter "technical instructions" and in the price list.

order-example:  
righthand version and grade  
RS11.008R04/AL41F





## MINICUT

Bohrungsbearbeitung

grooving, boring and profiling

## Typ Stechdrehen

Stechdrehen und Kopieren  
Vollradius

type grooving,  
grooving and profiling  
full radius

D min. 8 - 16 mm  
Vollradius R 0.4 - 2.0

D min. 8 - 16 mm  
full radius R 0.4 - 2.0

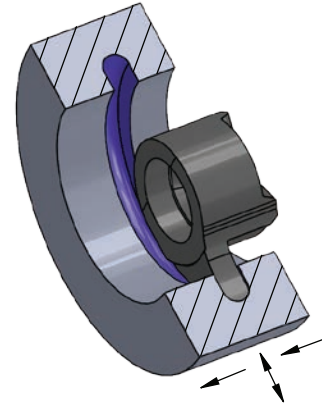
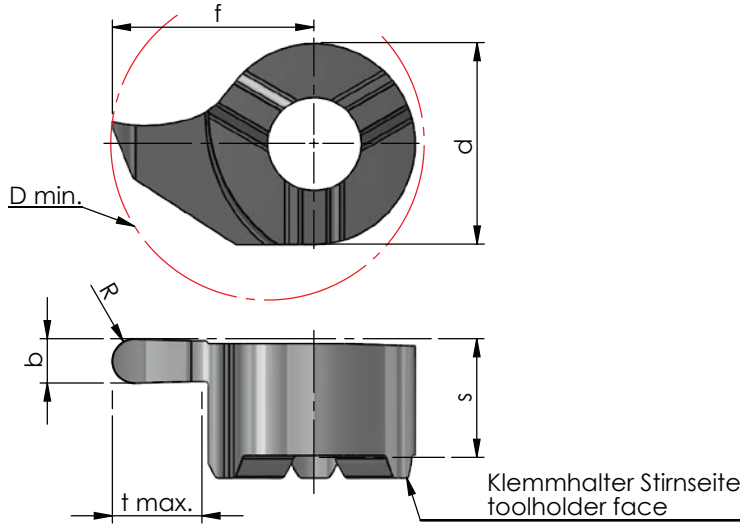

Rechts (R): wie gezeichnet  
Links (L): spiegelbildlich

righthand (R): as shown  
lefthand version (L): mirror image

Abmessungen in mm

dimensions in mm

Bestellnummer part number	b +0.05	b (inch)	R	f	s	d	t max.	D min.	Klemmhalter Typ toolholder type		
									K10F	AL41F	P18C
...											
R/L S16.016R08	1.60		0.80	10.2	5.4	11	4.3	16	●		
R/L S16.018R09	1.80		0.90	10.2	5.4	11	4.3	16	●		
R/L S16.020R10	2.00		1.00	10.2	5.4	11	4.3	16	●		
R/L S16.022R11	2.20		1.10	10.2	5.4	11	4.3	16	●		
R/L S16.024R12	2.40		1.20	10.2	5.4	11	4.3	16	●		616
R/L S16.030R15	3.00		1.50	10.2	5.4	11	4.3	16	●		
neu R/L S16.U31R15	3.18	0.125"	1.57	10.2	5.4	11	4.3	16	●		
R/L S16.032R16	3.20		1.60	10.2	5.4	11	4.3	16	●		
R/L S16.040R20	4.00		2.00	10.2	5.4	11	4.3	16	●		

Weitere HM Sorten können Sie in der Sortenübersicht im Kapitel "Technische Hinweise" und der Preisliste finden.

Bestellbeispiel:  
für rechte Ausführung und Sorte  
RS14.012R06/AL41F

More carbide grades you can find in the grades summary in the chapter "technical instructions" and in the price list.

order example:  
righthand version and grade  
RS14.012R06/AL41F

**BROTECH**

# MINICUT

Bohrungsbearbeitung

grooving, boring and profiling

# Typ Stechdrehen

Ausdrehen und Fasen

type grooving,  
boring and chamfering

D min. 8 - 14 mm

D min. 8 - 14 mm

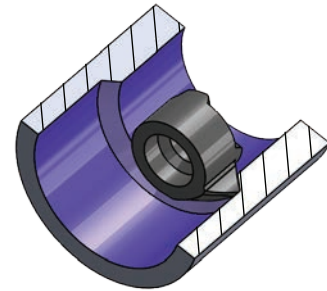
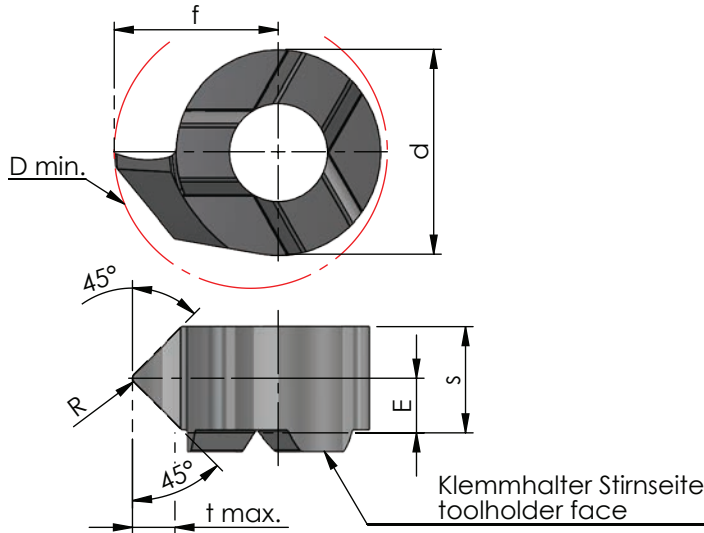

Rechts (R): wie gezeichnet  
Links (L): spiegelbildlich

righthand (R): as shown  
lefthand version (L): mirror image

Abmessungen in mm

dimensions in mm

Bestellnummer part number	R	f	s	E	d	Ap max.*	t max.	D min.	Klemmhalter Typ toolholder type				
									K10F	AL41F	P18C	CBN	
R/L S08.4545.02	0.2	4.8	3.70	1.60	6.0	0.6	1.4	8	●				608
R/L S09.4545.02	0.2	5.5	3.55	1.80	6.2	0.8	1.3	9		●			609
R/L S11.4545.02	0.2	6.7	4.30	2.20	8.0	1.0	1.5	11	●	●			611
R/L S14.4545.02	0.2	9.0	5.35	2.70	9.0	1.2	1.5	14	●	●			614

\*Ap max. = max. Schnitttiefe(werkstoffabhängig)

Weitere HM Sorten können Sie in der Sortenübersicht im Kapitel "Technische Hinweise" und der Preisliste finden.

Bestellbeispiel: für rechte Ausführung und Sorte RS08.4545.02/AL41F

\*Ap max. = maximum depth of cut (depending on material)

More carbide grades you can find in the grades summary in the chapter "Technical instructions" and in the price list.  
order-example: righthand version and grade RS08.4545.02/AL41F

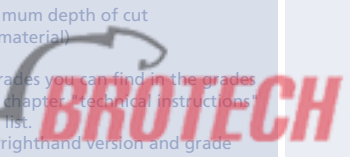

## MINICUT

Bohrungsbearbeitung

grooving, boring and profiling

## Typ Stechdrehen

Vorstechen und Fasen

type grooving,  
pregrooving and chamfering

D min. 8 - 16 mm

D min. 8 - 16 mm

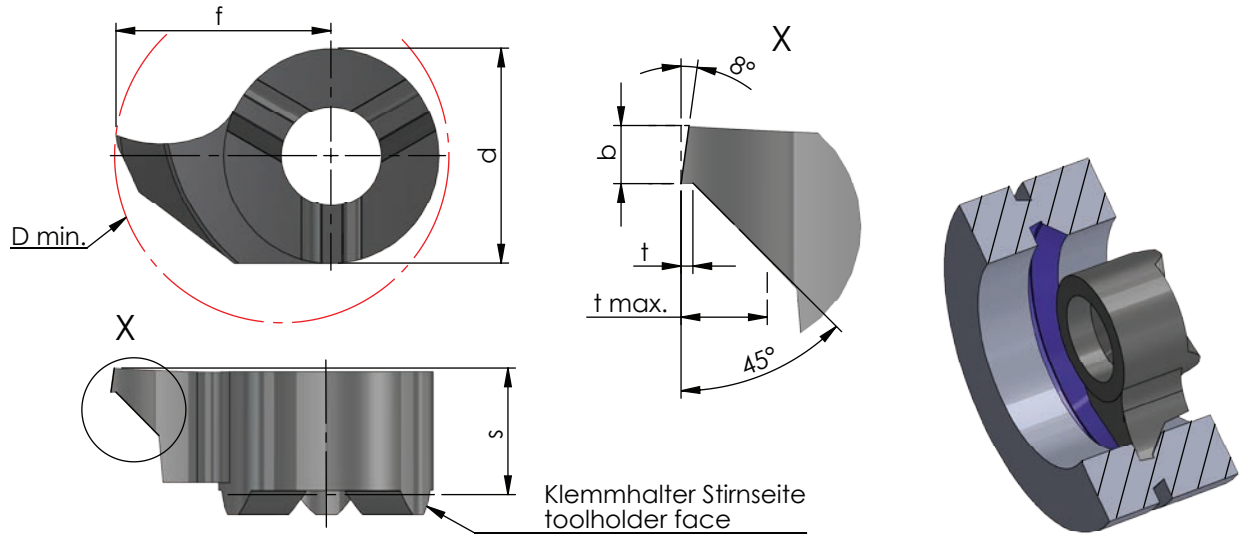

Rechts (R): wie gezeichnet  
Links (L): spiegelbildlich

righthand (R): as shown  
lefthand version (L): mirror image

Abmessungen in mm

dimensions in mm

Bestellnummer part number	b	t	f	s	d	t max.	D min.	Klemmhalter Typ toolholder type			
								K10F	AL41F	P18C	
R/L S08.0810.45	1	0.2	4.8	3.3	6.0	1.0	8	●			608
R/L S09.0810.45	1	0.2	5.5	3.6	6.2	1.5	9	●			609
R/L S11.0810.45	1	0.2	6.7	4.2	8.0	1.5	11	●			611
R/L S14.0815.45	1	0.2	9.0	5.3	9.0	1.5	14	●			614
R/L S16.0815.45	1	0.2	10.2	5.4	11.0	1.5	16	●			616

Weitere HM Sorten können Sie in der Sortenübersicht im Kapitel "Technische Hinweise" und der Preisliste finden.

Bestellbeispiel:  
für rechte Ausführung und Sorte  
RS14.0815.45/AL41F

More carbide grades you can find in the grades summary in the chapter "technical instructions" and in the price list.

order example:  
righthand version and grade  
RS14.0815.45/AL41F

**BROTECH**

# MINICUT

Bohrungsbearbeitung

grooving, boring and profiling

# Typ Gewindedrehen

metrisches ISO-Gewinde,  
Teilprofil, innen

type threading,  
metric ISO-thread,  
partial profile, internal

D min. 8 / 9 mm  
Steigung P = 0.5 - 3.5

D min. 8 / 9 mm  
pitch P = 0.5 - 3.5

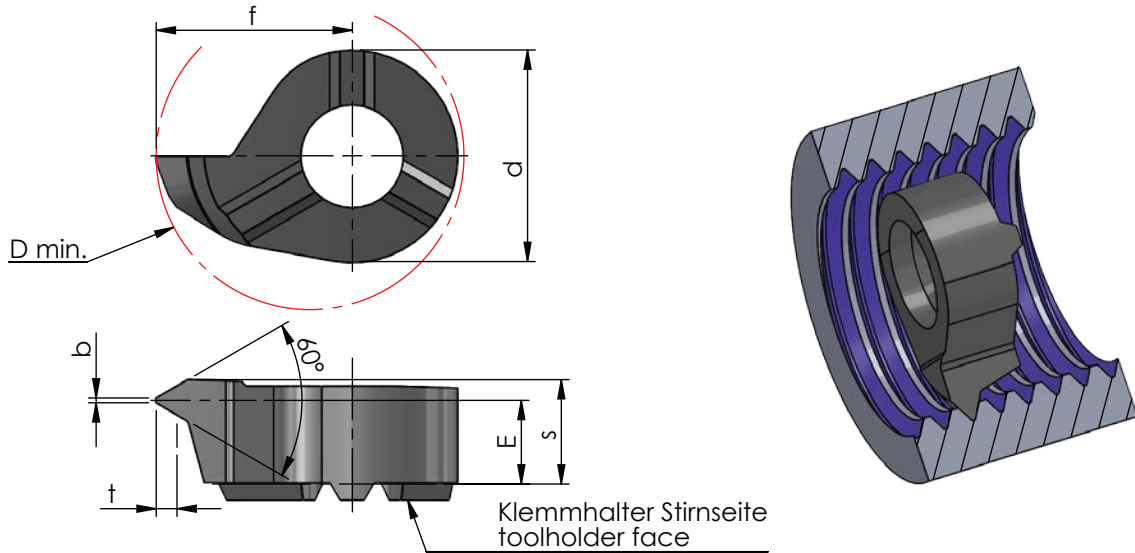

Klemmhalter Stirnseite  
toolholder face

Rechts (R): wie gezeichnet  
Links (L): spiegelbildlich

righthand (R): as shown  
lefthand version (L): mirror image

Abmessungen in mm

dimensions in mm



Bestellnummer part number	Steigung P pitch P	t	b	f	s	d	E	D min.				Klemmhalter Typ toolholder type
									K10F	AL41F	P18C	
R/L S08.0205.01	0.5-0.75	0.43	0.06	4.8	3.40	6.0	2.95	8		●		608
R/L S08.0510.01	1.0-1.25	0.70	0.12	4.8	3.40	6.0	2.70	8	●	●		
R/L S08.0815.01	1.5-1.75	0.95	0.18	4.8	3.40	6.0	2.50	8	●	●		
R/L S09.0205.01	0.5-0.75	0.27	0.06	5.5	3.55	6.2	3.20	9		●		609
R/L S09.0510.01	1.0-1.25	0.54	0.12	5.5	3.55	6.2	3.00	9		●		
R/L S09.0815.01	1.5-1.75	0.81	0.18	5.5	3.55	6.2	2.80	9		●		
R/L S09.0917.01	1.75-2.0	0.95	0.20	5.5	3.55	6.2	2.60	9		●		
R/L S09.1020.01	2.0-2.5	1.08	0.25	5.5	3.55	6.2	2.50	9		●		
R/L S09.1325.01	2.5-3.0	1.35	0.31	5.5	3.55	6.2	2.10	9		●		
R/L S09.1630.01	3.0-3.5	1.62	0.37	5.5	3.55	6.2	1.90	9		●		

Weitere HM Sorten können Sie in der Sortenübersicht im Kapitel "Technische Hinweise" und der Preisliste finden.

Bestellbeispiel:  
für rechte Ausführung und Sorte  
RS08.0205.01/AL41F

More carbide grades you can find in the grades summary in the chapter "technical instructions" and in the price list.

order example:  
righthand version and grade  
RS08.0205.01/AL41F



## MINICUT

Bohrungsbearbeitung

grooving, boring and profiling

## Typ Gewindedrehen

metrisches ISO-Gewinde,  
Teilprofil, innen

type threading,  
metric ISO-thread,  
partial profile, internal

D min. 11 / 14 / 16 mm  
Steigung P = 0.5 - 3.0

D min. 11 / 14 / 16 mm  
pitch P = 0.5 - 3.0

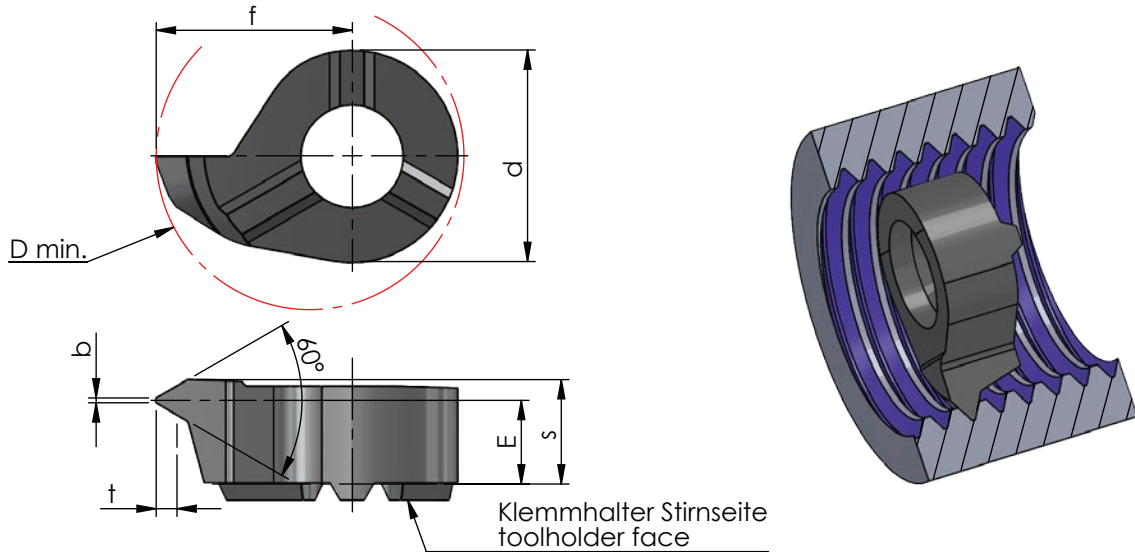

Rechts (R): wie gezeichnet  
Links (L): spiegelbildlich

righthand (R): as shown  
lefthand version (L): mirror image

Abmessungen in mm

dimensions in mm

Bestellnummer part number	Steigung P pitch P	t	b	f	s	d	E	D min.				Klemmhalter Typ toolholder type
									K10F	AL41F	P18C	
R/L S11.0205.01	0.5-0.75	0.41	0.06	6.7	4.2	8	3.75	11		●		
R/L S11.0510.01	1.0-1.25	0.55	0.12	6.7	4.2	8	3.60	11		●		
R/L S11.0815.01	1.5-1.75	0.81	0.18	6.7	4.2	8	3.40	11		●		611
R/L S11.1020.01	2.0-2.5	1.08	0.25	6.7	4.2	8	3.15	11		●		
R/L S11.1325.01	2.5-3.0	1.35	0.31	6.7	4.2	8	2.95	11		●		
R/L S14.0510.01	1.0-1.25	0.55	0.12	9.0	5.4	9	4.60	14		●		
R/L S14.0815.01	1.5-1.75	0.81	0.18	9.0	5.4	9	4.30	14		●		614
R/L S14.1020.01	2.0-2.5	1.08	0.25	9.0	5.4	9	3.90	14		●		
R/L S14.1325.01	2.5-3.0	1.35	0.31	9.0	5.4	9	3.55	14		●		
R/L S16.0510.01	1.0-1.25	0.55	0.12	10.2	5.4	11	4.80	16		●		
R/L S16.0815.01	1.5-1.75	0.81	0.18	10.2	5.4	11	4.60	16		●		616
R/L S16.1020.01	2.0-2.5	1.08	0.25	10.2	5.4	11	4.35	16		●		
R/L S16.1325.01	2.5-3.0	1.35	0.31	10.2	5.4	11	4.15	16		●		

Weitere HM Sorten können Sie in der Sortenübersicht im Kapitel "Technische Hinweise" und der Preisliste finden.

Bestellbeispiel:  
für rechte Ausführung und Sorte  
RS14.0510.01/AL41F

More carbide grades you can find in the grades summary in the chapter "technical instructions" and in the price list.

order example:  
righthand version and grade  
RS14.0510.01/AL41F

**BROTECH**

# MINICUT

Bohrungsbearbeitung

grooving, boring and profiling

# Typ Gewindedrehen

metrisches ISO-Gewinde,  
Vollprofil, innen

type threading,  
metric ISO-thread,  
full profile, internal

D min. 9 / 11 mm  
Steigung P = 0.5 - 3.0

D min. 9 / 11 mm  
pitch P = 0.5 - 3.0

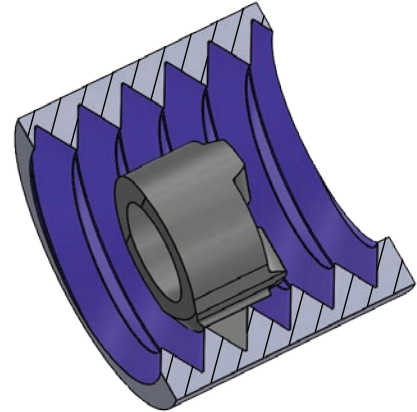
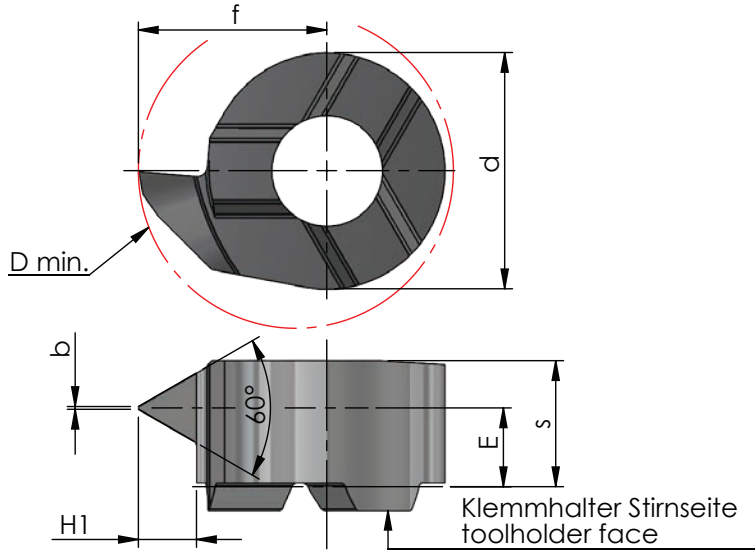

Rechts (R): wie gezeichnet  
Links (L): spiegelbildlich

righthand (R): as shown  
lefthand version (L): mirror image

Abmessungen in mm

dimensions in mm

Bestellnummer part number	Steigung P pitch P	H1	b	f	s	d	E	D min.	K10F	AL41F	P18C	Klemmhalter Typ toolholder type
R/L S09.0205.02	0.50	0.27	0.06	5.5	3.65	6.2	3.25	9	●			609
R/L S09.0510.02	1.00	0.54	0.12	5.5	3.65	6.2	3.00	9	●			
R/L S09.0815.02	1.50	0.81	0.18	5.5	3.60	6.2	2.80	9	●			
R/L S09.0917.02	1.75	0.95	0.20	5.5	3.60	6.2	2.70	9	●			
R/L S09.1020.02	2.00	1.08	0.25	5.5	3.55	6.2	2.60	9	●			
R/L S09.1325.02	2.50	1.35	0.31	5.5	3.55	6.2	2.50	9	●			
R/L S09.1630.02	3.00	1.62	0.37	5.5	3.55	6.2	2.20	9	●			
R/L S11.0510.02	1.00	0.54	0.12	6.7	4.30	8.0	3.60	11	●		611	
R/L S11.0815.02	1.50	0.81	0.18	6.7	4.30	8.0	3.30	11	●			
R/L S11.1020.02	2.00	1.08	0.25	6.7	4.30	8.0	2.90	11	●			
R/L S11.1325.02	2.50	1.35	0.31	6.7	4.30	8.0	2.95	11	●			
R/L S11.1630.02	3.00	1.62	0.37	6.7	4.30	8.0	2.90	11	●			

Weitere HM Sorten können Sie in der Sortenübersicht im Kapitel "Technische Hinweise" und der Preisliste finden.

Bestellbeispiel:  
für rechte Ausführung und Sorte  
RS11.1630.02/AL41F

More carbide grades you can find in the grades summary in the chapter "technical instructions" and in the price list.

order example:  
righthand version and grade  
RS11.1630.02/AL41F



## MINICUT

Bohrungsbearbeitung

grooving, boring and profiling

## Typ Gewindedrehen

metrisches ISO-Gewinde,  
Vollprofil, innen

type threading,  
metric ISO-thread,  
full profile, internal

D min. 14 / 16 mm  
Steigung P = 0.5 - 4.0

D min. 14 / 16 mm  
pitch P = 0.5 - 4.0

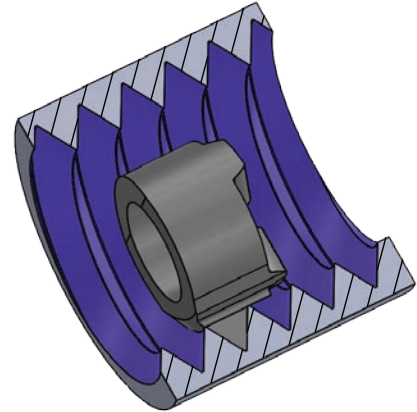
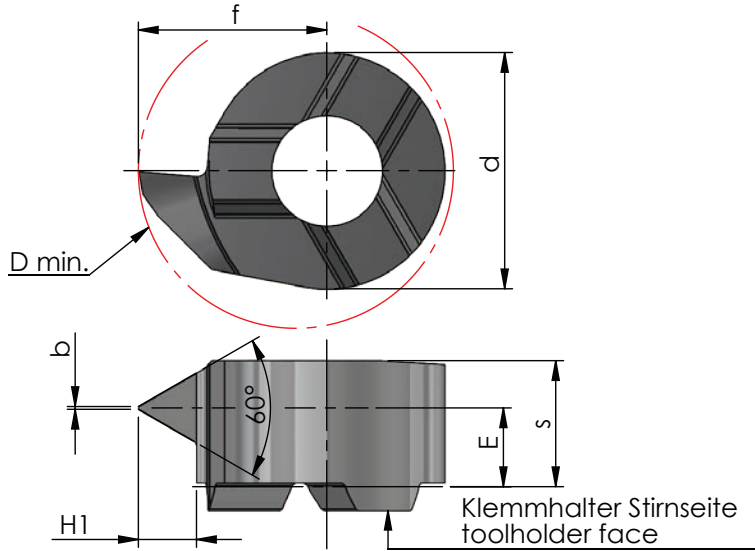

Rechts (R): wie gezeichnet  
Links (L): spiegelbildlich

righthand (R): as shown  
lefthand version (L): mirror image

Abmessungen in mm

dimensions in mm

Bestellnummer part number	Steigung P pitch P	H1	b	f	s	d	E	D min.				Klemmhalter Typ toolholder type
									K10F	AL41F	P18C	
R/L S14.0205.02	0.5	0.27	0.06	9.0	5.4	9	4.80	14		●		
R/L S14.0510.02	1.0	0.54	0.12	9.0	5.4	9	4.70	14		●		
R/L S14.0815.02	1.5	0.81	0.18	9.0	5.4	9	4.30	14		●		614
R/L S14.1020.02	2.0	1.08	0.25	9.0	5.4	9	4.20	14		●		
R/L S14.1325.02	2.5	1.35	0.31	9.0	5.4	9	3.65	14		●		
R/L S16.0510.02	1.0	0.54	0.12	10.2	5.5	11	4.80	16		●		
R/L S16.0815.02	1.5	0.81	0.18	10.2	5.5	11	4.30	16		●		
R/L S16.1020.02	2.0	1.08	0.25	10.2	5.5	11	4.05	16		●		
R/L S16.1325.02	2.5	1.35	0.31	10.2	5.5	11	4.20	16		●		616
R/L S16.1630.02	3.0	1.62	0.37	10.2	5.5	11	4.00	16		●		
R/L S16.1835.02	3.5	1.89	0.43	10.2	5.5	11	3.90	16		●		
R/L S16.2140.02	4.0	2.16	0.50	10.2	5.5	11	3.60	16		●		

Weitere HM Sorten können Sie in der Sortenübersicht im Kapitel "Technische Hinweise" und der Preisliste finden.

Bestellbeispiel:  
für rechte Ausführung und Sorte  
RS16.0510.02/AL41F

More carbide grades you can find in the grades summary in the chapter "technical instructions" and in the price list.

order example:  
righthand version and grade  
RS16.0510.02/AL41F

**BROTECH**

# MINICUT

Bohrungsbearbeitung

grooving, boring and profiling

# Typ Gewindedrehen

NPT Vollprofil,  
innen

type threading,  
NPT full profile, internal

D min. 8 mm

D min. 8 mm

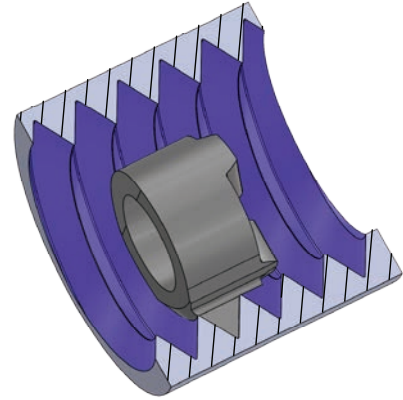
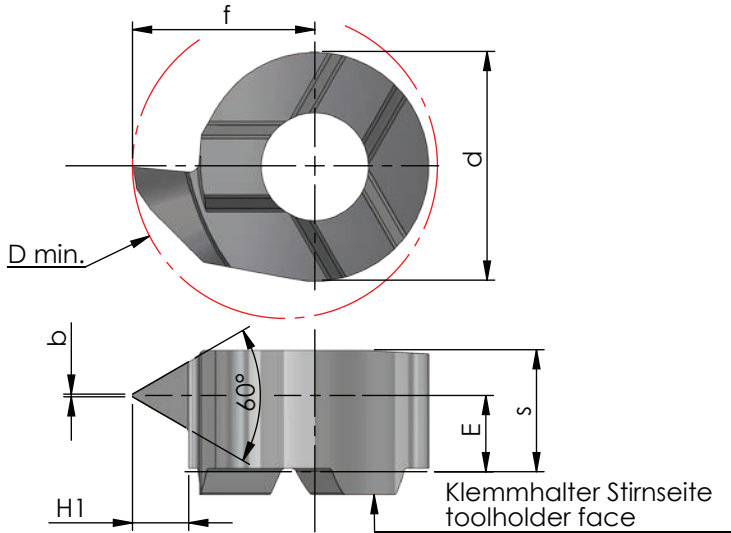

Rechts (R): wie gezeichnet  
Links (L): spiegelbildlich

righthand (R): as shown  
lefthand version (L): mirror image

Abmessungen in mm

dimensions in mm



Bestellnummer part number	Steigung P pitch P	H1	Gang / Zoll threads / inch	b	f	s	d	E	D min.	K10F	AL41F	P18C	Klemmhalter Typ toolholder type
R/L S08.NP14.02	1.814	1.48	14	0.07	4.8	3.2	6	2.0	8	●			
R/L S08.NP18.02	1.411	1.19	18	0.05	4.8	3.5	6	2.6	8	●			608
R/L S08.NP27.02	0.940	0.80	27	0.04	4.8	3.5	6	2.8	8	●			

Weitere HM Sorten können Sie in der Sortenübersicht im Kapitel "Technische Hinweise" und der Preisliste finden.

Bestellbeispiel:  
für rechte Ausführung und Sorte  
RS08.NP14.02/AL41F

More carbide grades you can find in the grades summary in the chapter "technical instructions" and in the price list.

order example:  
righthand version and grade  
RS08.NP14.02/AL41F

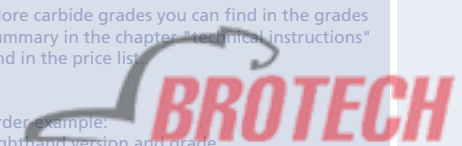



## MINICUT

Bohrungsbearbeitung

grooving, boring and profiling

## Typ Gewindedrehen

Whitworth-Gewinde,  
Vollprofil, innen

D min. 11 / 14 / 16 mm

type threading,  
Whitworth thread,  
full profile, internal

D min. 11 / 14 / 16 mm

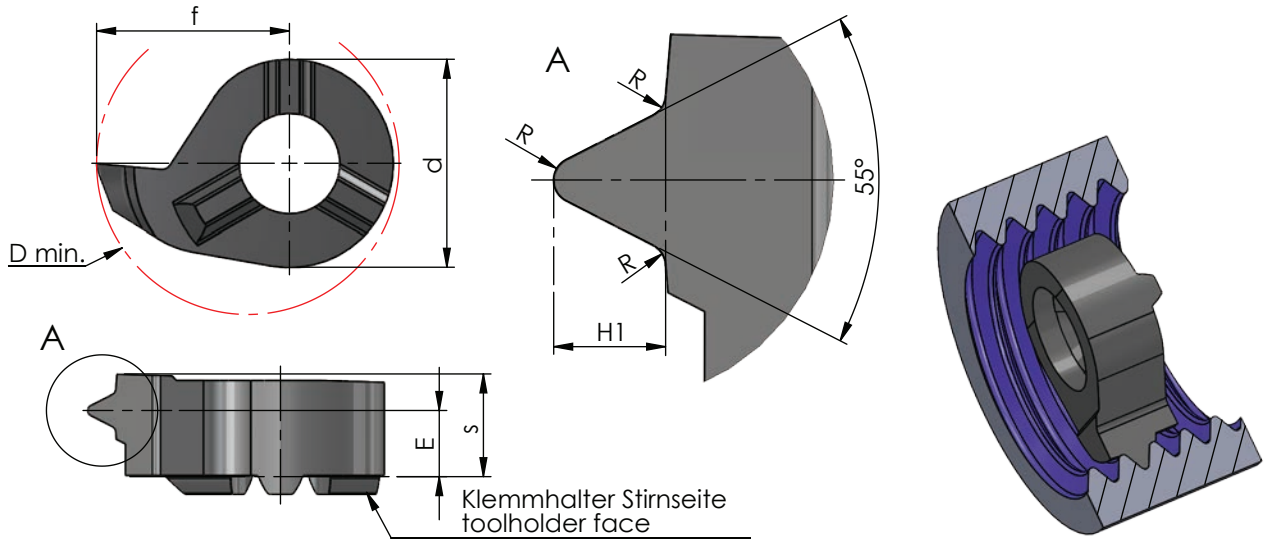

Rechts (R): wie gezeichnet  
Links (L): spiegelbildlich

righthand (R): as shown  
lefthand version (L): mirror image

Abmessungen in mm

dimensions in mm

Bestellnummer part number	Steigung P pitch P	H1	Gang / Zoll threads / inch	R	f	s	d	E	D min.				Klemmhalter Typ toolholder type
										K10F	AL41F	P18C	
R/L S11.0813.19	1.337	0.85	19	0.18	6.7	4.3	8	2.7	11	●			
R/L S11.1118.14	1.814	1.16	14	0.24	6.7	4.3	8	3.0	11	●			611
R/L S14.0813.19	1.337	0.85	19	0.18	9.0	5.35	9	3.8	14	●			614
R/L S14.1118.14	1.814	1.16	14	0.24	9.0	5.40	9	3.6	14	●			
R/L S16.1118.14	1.814	1.16	14	0.24	10.2	5.4	11	3.9	16	●			616
R/L S16.1423.11	2.309	1.48	11	0.31	10.2	5.4	11	3.5	16	●			

Weitere HM Sorten können Sie in der Sortenübersicht im Kapitel "Technische Hinweise" und in der Preisliste finden.

Bestellbeispiel:  
für rechte Ausführung und Sorte  
RS16.1423.11/AL41F

More carbide grades you can find in the grades summary in the chapter "technical instructions" and in the price list.

order example:  
righthand version and grade  
RS16.1423.11/AL41F

**BROTECH**

# MINICUT

Bohrungsbearbeitung

grooving, boring and profiling

# Typ Gewindedrehen

Trapezgewinde,  
Teilprofil, innen

type threading,  
trapezoidal thread,  
partial profile, internal

D min. 9 / 10 / 11 mm  
Steigung P = 1.5 - 4.0

D min. 9 / 10 / 11 mm  
pitch P = 1.5 - 4.0

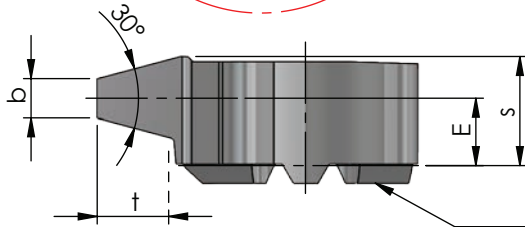
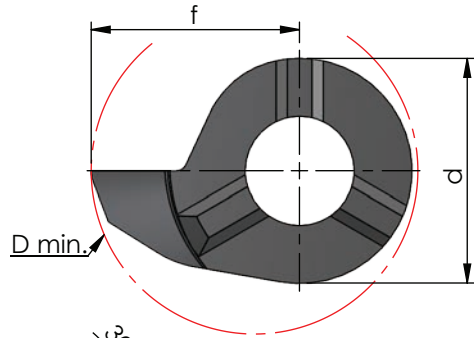

Klemmhalter Stirnseite  
toolholder face

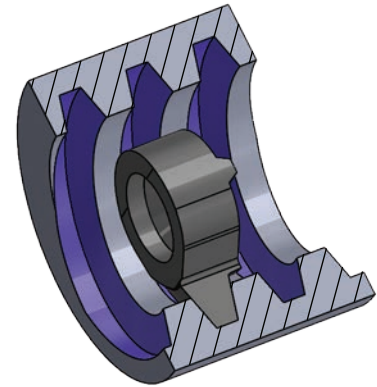

Rechts (R): wie gezeichnet  
Links (L): spiegelbildlich

righthand (R): as shown  
lefthand version (L): mirror image

Abmessungen in mm

dimensions in mm



Bestellnummer part number	Steigung P pitch P	t	b	f	s	d	E	D min.	Klemmhalter Typ toolholder type			
									K10F	AL41F	P18C	
R/L S09.1015.01	1.5	0.90	0.47	5.5	3.55	6.2	3.00	9	●	●	●	609
R/L S09.1220.01	2.0	1.25	0.60	5.5	3.55	6.2	2.85	9	●	●	●	
R/L S09.1730.01	3.0	1.75	0.96	5.5	3.55	6.2	2.25	9	●	●	●	
R/L S09.2240.01	4.0	2.25	1.33	6.5	3.55	6.2	2.25	10	●	●	●	
R/L S11.1015.01	1.5	0.90	0.47	6.7	4.30	8.0	3.7	11	●	●	●	611
R/L S11.1220.01	2.0	1.25	0.60	6.7	4.30	8.0	3.5	11	●	●	●	
R/L S11.1730.01	3.0	1.75	0.96	6.7	4.30	8.0	3.2	11	●	●	●	
R/L S11.2240.01	4.0	2.25	1.33	6.7	4.00	8.0	2.6	11	●	●	●	

Weitere HM Sorten können Sie in der Sortenübersicht im Kapitel "Technische Hinweise" und der Preisliste finden.

Bestellbeispiel:  
für rechte Ausführung und Sorte  
RS09.1015.01/AL41F

More carbide grades you can find in the grades summary in the chapter "technical instructions" and in the price list.

order example:  
righthand version and grade  
RS09.1015.01/AL41F



## MINICUT

Bohrungsbearbeitung

grooving, boring and profiling

## Typ Gewindedrehen

Trapezgewinde,  
Teilprofil, innen

type threading,  
trapezoidal thread,  
partial profile, internal

D min. 14 / 16 mm  
Steigung P = 2.0 - 6.0

D min. 14 / 16 mm  
pitch P = 2.0 - 6.0

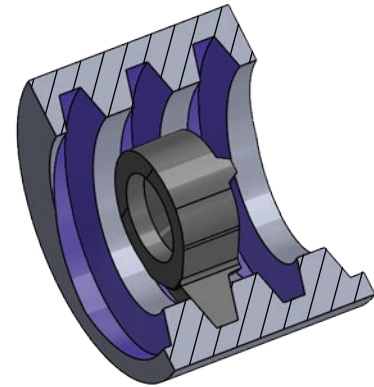
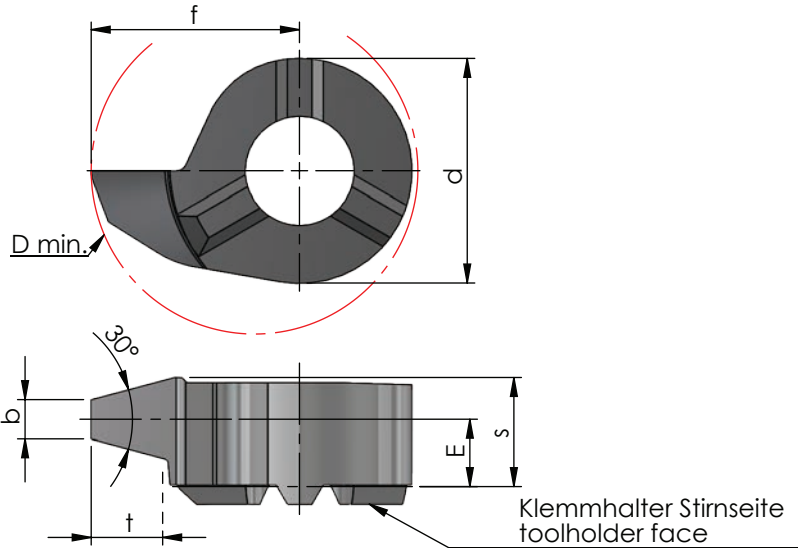

Rechts (R): wie gezeichnet  
Links (L): spiegelbildlich

righthand (R): as shown  
lefthand version (L): mirror image

Abmessungen in mm

dimensions in mm

Bestellnummer part number	Steigung P pitch P	t	b	f	s	d	E	D min.	Klemmhalter Typ toolholder type		
									K10F	AL41F	P18C
R/L S14.1220.01	2.0	1.25	0.60	9.0	5.3	9.0	4.3	14	●		
R/L S14.1730.01	3.0	1.75	0.96	9.0	5.3	9.0	4.0	14	●		
R/L S14.2240.01	4.0	2.25	1.33	9.0	5.3	9.0	4.0	14	●		614
R/L S14.2750.01	5.0	2.75	1.69	9.0	5.3	9.0	3.55	14	●		
R/L S16.1220.01	2.0	1.25	0.60	9.7	5.5	11	4.5	16	●		
R/L S16.1730.01	3.0	1.75	0.96	9.7	5.5	11	4.3	16	●		
R/L S16.2240.01	4.0	2.25	1.33	9.7	5.5	11	4.0	16	●		616
R/L S16.2750.01	5.0	2.75	1.69	10.2	5.5	11	3.6	16	●		
R/L S16.3560.01	6.0	3.50	1.92	10.2	5.5	11	3.3	16	●		

Weitere HM Sorten können Sie in der Sortenübersicht im Kapitel "Technische Hinweise" und der Preisliste finden.

Bestellbeispiel:  
für rechte Ausführung und Sorte  
RS14.1220.01AL41F

More carbide grades you can find in the grades summary in the chapter "technical instructions" and in the price list.

order example:  
righthand version and grade  
RS14.1220.01AL41F

**BROTECH**

# MINICUT

Bohrungsbearbeitung

grooving, boring and profiling

# Typ Axialstechen

allgemein

type face grooving

D min. 14 / 18 mm  
 Stechtiefe t max. 6 / 10 mm  
 Nutbreite bis 3.0 / 4.0 mm

D min. 14 / 18 mm  
 depth of groove t max. 6 / 10 mm  
 width of groove up to 3.0 / 4.0 mm

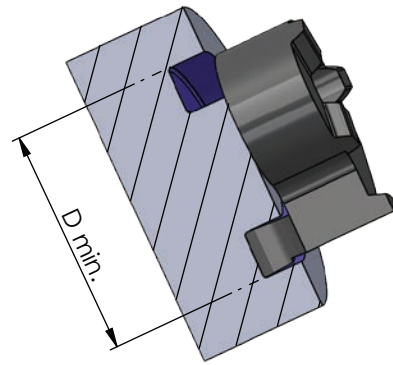
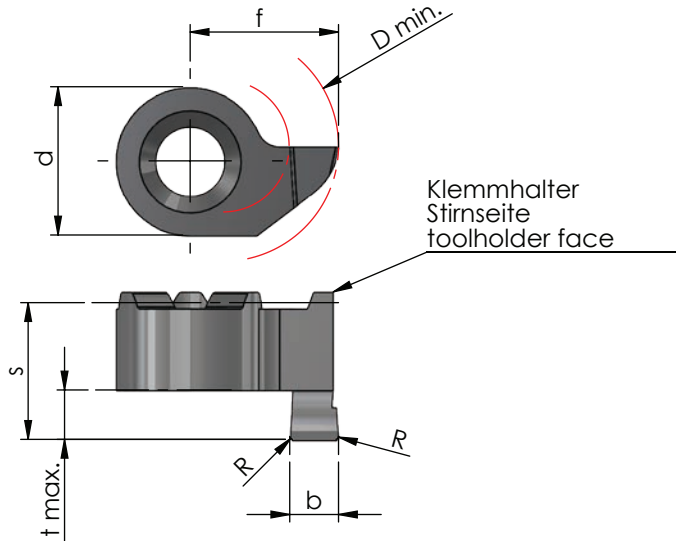

Rechts (R): wie gezeichnet  
 Links (L): spiegelbildlich

righthand (R): as shown  
 lefthand version (L): mirror image

Abmessungen in mm

dimensions in mm



Bestellnummer part number	b+0.03	f	R	s	d	t max.	D min.				Klemmhalter Typ toolholder type
								K10F	AL41F	P18C	
R/L S014.1410.00	1.0	9	-	8.3	9	1.5	14	●			614 614.A
R/L S014.1415.02	1.5	9	0.2	8.3	9	2.5	14	●	●		
R/L S014.1420.02	2.0	9	0.2	8.3	9	3.0	14	●	●		
R/L S014.1425.02	2.5	9	0.2	8.3	9	3.0	14	●	●		
R/L S014.1430.02	3.0	9	0.2	8.3	9	3.0	14		●		
R/L S014.1420.52	2.0	9	0.2	10.3	9	5.0	14	●	●		
R/L S014.1425.52	2.5	9	0.2	10.3	9	5.0	14	●	●		
R/L S014.1430.52	3.0	9	0.2	10.3	9	5.0	14	●	●		
R/- S014.1430.62	3.0	9	0.2	11.3	9	6.0	14		●		
R/L S018.1830.02	3.0	11	0.2	15.8	11	10	18	●			618
R/L S018.1840.02	4.0	11.5	0.2	15.8	11	10	18	●			618.A

Weitere HM Sorten können Sie in der Sortenübersicht im Kapitel "Technische Hinweise" und der Preisliste finden.

Bestellbeispiel:  
 für rechte Ausführung und Sorte  
 RS014.1410.00/AL41F

More carbide grades you can find in the grades summary in the chapter "technical instructions" and in the price list.

order example:  
 righthand version and grade  
 RS014.1410.00/AL41F



## MINICUT

Bohrungsbearbeitung

grooving, boring and profiling

## Typ Axialstechen

am Zapfen vorbei

type face grooving,  
in pivots

D min. 12 / 16 mm  
Stechtiefe t max. 6 / 10 mm  
Nutbreite bis 3.0 / 4.0 mm

D min. 12 / 16 mm  
depth of groove t max. 6 / 10 mm  
width of groove up to 3.0 / 4.0 mm

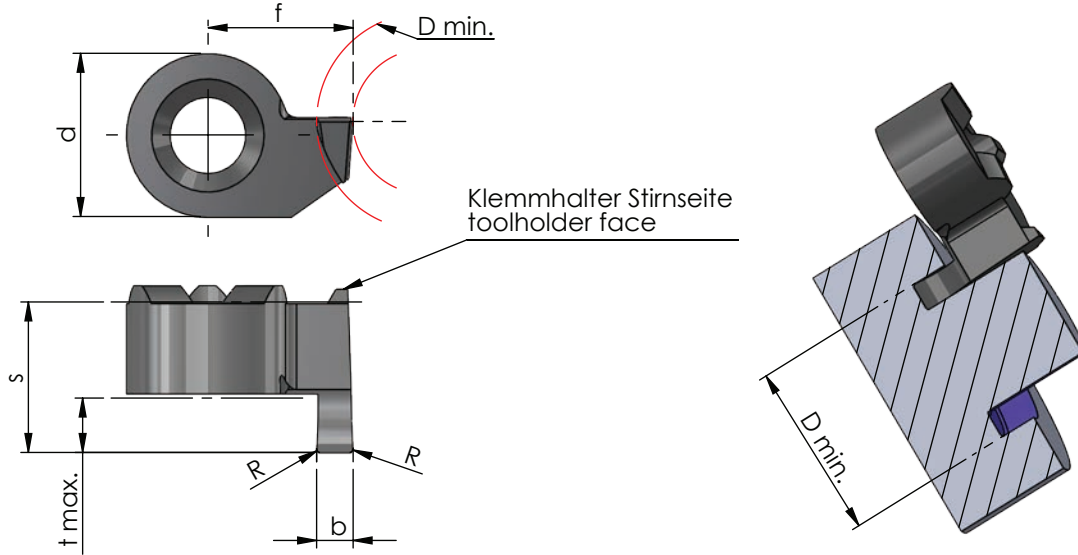

Rechts (R): wie gezeichnet  
Links (L): spiegelbildlich

righthand (R): as shown  
lefthand version (L): mirror image

Abmessungen in mm

dimensions in mm

Bestellnummer part number	b		f	R	s	d	t max.	D min.	K10F AL41F P18C	Klemmhalter Typ toolholder type
	b+0.03	b (inch)								
R/L S014.1210.00	1.0		7.0	-	8.3	9	1.5	12	● ●	614 614.A
R/L S014.1215.02	1.5		7.5	0.2	8.3	9	2.5	12	● ●	
R/L S014.U219.02	1.98	0.078"	8.0	0.2	8.3	9	3.0	12	● ●	
R/L S014.1220.02	2.0		8.0	0.2	8.3	9	3.0	12	● ●	
R/L S014.U223.02	2.39	0.094"	8.4	0.2	8.3	9	3.0	12	● ●	
R/L S014.1225.02	2.5		8.5	0.2	8.3	9	3.0	12	● ●	
R/L S014.1230.02	3.0		9.0	0.2	8.3	9	3.0	12	● ●	
R/L S014.U231.02	3.18	0.125"	9.2	0.2	8.3	9	3.0	12	● ●	
R/L S014.1220.52	2.0		8.0	0.2	10.3	9	5.0	12	● ●	
R/L S014.1225.52	2.5		8.5	0.2	10.3	9	5.0	12	● ●	
R/L S014.1230.52	3.0		9.0	0.2	10.3	9	5.0	12	● ●	
R/- S014.1230.62	3.0		9.0	0.2	11.3	9	6.0	12	● ●	
R/L S018.1630.02	3.0		11	0.2	15.8	11	10	16	● ●	618 618.A
R/L S018.1640.02	4.0		12	0.2	15.8	11	10	16	● ●	

Weitere HM Sorten können Sie in der Sortenübersicht im Kapitel "Technische Hinweise" und der Preisliste finden.

Bestellbeispiel:  
für rechte Ausführung und Sorte  
RS014.1210.00/AL41F

More carbide grades you can find in the grades summary in the chapter "technical instructions" and in the price list.

order example:  
righthand version and grade  
RS014.1210.00/AL41F

**BROTECH**

# MINICUT

Bohrungsbearbeitung

grooving, boring and profiling

## Typ Axialstechen

Vollradius

type face grooving,  
full radius

D min. 14 mm  
Stechtiefe t max. 5 mm  
Nutbreite bis 3.0 mm

D min. 14 mm  
depth of groove t max. 5 mm  
width of groove up to 3.0 mm

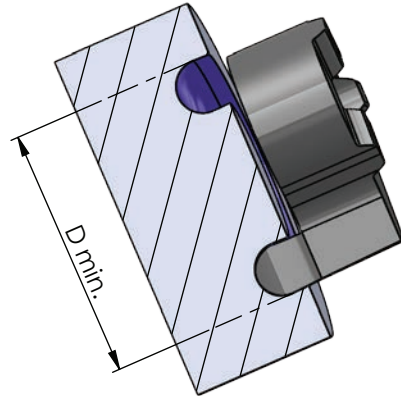
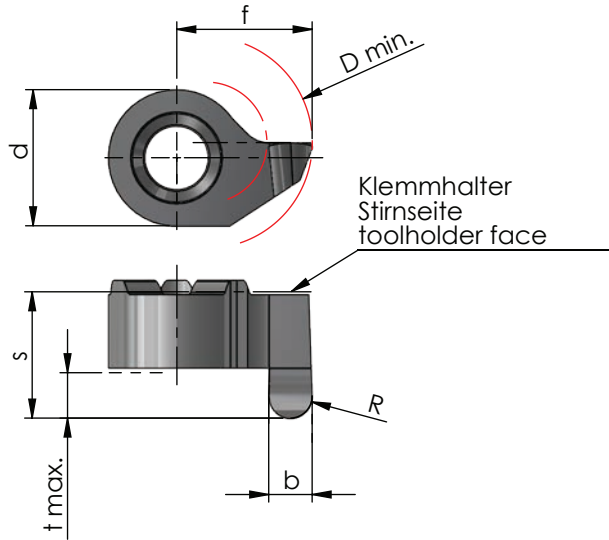

Rechts (R): wie gezeichnet  
Links (L): spiegelbildlich

righthand (R): as shown  
lefthand version (L): mirror image

Abmessungen in mm

dimensions in mm



Bestellnummer part number	b		f	R	s	d	t max.	D min.	K10F AL41F P18C	Klemmhalter Typ toolholder type
	b+0.03	b (inch)								
R/L S014.1410.05	1.0		9	0.5	8.3	9	1.5	14	●	614 614A
R/L S014.U411.05	1.17	0.046"	9	0.58	8.3	9	1.5	14	●	
R/L S014.1416.08	1.6		9	0.8	8.3	9	2.5	14	●	
R/L S014.1420.10	2.0		9	1.0	8.3	9	3.0	14	●	
R/L S014.1425.12	2.5		9	1.25	8.3	9	3.0	14	●	
R/L S014.1430.15	3.0		9	1.5	8.3	9	3.0	14	●	
R/L S014.1420.50	2.0		9	1.0	10.3	9	5.0	14	●	
R/L S014.1425.50	2.5		9	1.25	10.3	9	5.0	14	●	
R/L S014.1430.50	3.0		9	1.5	10.3	9	5.0	14	●	

Weitere HM Sorten können Sie in der Sortenübersicht im Kapitel "Technische Hinweise" und der Preisliste finden.

Bestellbeispiel:  
für rechte Ausführung und Sorte  
RS014.1410.05/AL41F

More carbide grades you can find in the grades summary in the chapter "technical instructions" and in the price list.

order-example:  
righthand version and grade  
RS014.1410.05/AL41F



## MINICUT

Bohrungsbearbeitung

grooving, boring and profiling

## Typ Axialstechen

am Zapfen vorbei,  
Vollradius

type face grooving,  
in pivots, full radius

D min. 12 mm  
Stechtiefe t max. 5 mm  
Nutbreite bis 3.0 mm

D min. 12 mm  
depth of groove t max. 5 mm  
width of groove up to 3.0 mm

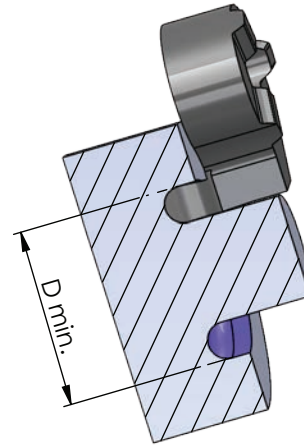
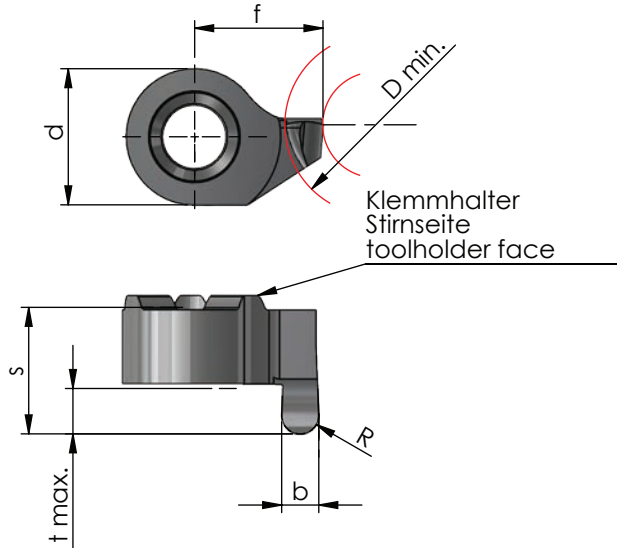

Rechts (R): wie gezeichnet  
Links (L): spiegelbildlich

righthand (R): as shown  
lefthand version (L): mirror image

Abmessungen in mm

dimensions in mm

Bestellnummer part number	b+0.03	f	R	s	d	t max.	D min.				Klemmhalter Typ toolholder type
								K10F	AL41F	P18C	
R/L S014.1210.05	1.0	7.0	0.5	8.3	9	1.5	12	●			
R/L S014.1216.08	1.6	7.6	0.8	8.3	9	2.5	12	●			614
R/L S014.1220.10	2.0	8.0	1.0	8.3	9	3.0	12	●			
R/L S014.1225.12	2.5	8.5	1.25	8.3	9	3.0	12	●			
R/L S014.1230.15	3.0	9.0	1.5	8.3	9	3.0	12	●			
R/L S014.1220.50	2.0	8.0	1.0	10.3	9	5.0	12	●			614
R/L S014.1225.50	2.5	8.5	1.25	10.3	9	5.0	12	●			614A
R/L S014.1230.50	3.0	9.0	1.5	10.3	9	5.0	12	●			

Weitere HM Sorten können Sie in der Sortenübersicht im Kapitel "Technische Hinweise" und der Preisliste finden.

Bestellbeispiel:  
für rechte Ausführung und Sorte  
RS014.1210.05/AL41F

More carbide grades you can find in the grades summary in the chapter "technical instructions" and in the price list.

order example:  
righthand version and grade  
RS014.1210.05/AL41F

**BROTECH**

# MINICUT

Bohrungsbearbeitung

grooving, boring and profiling

# Impressionen

impressions

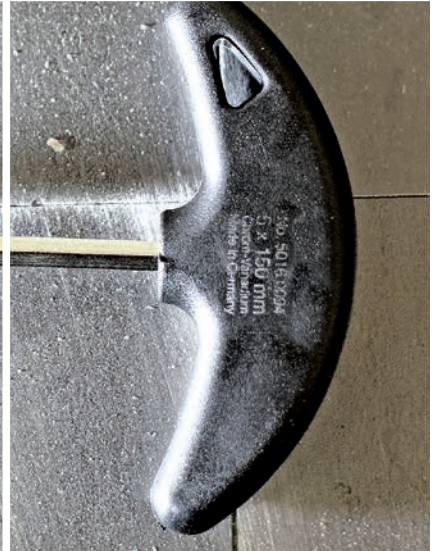
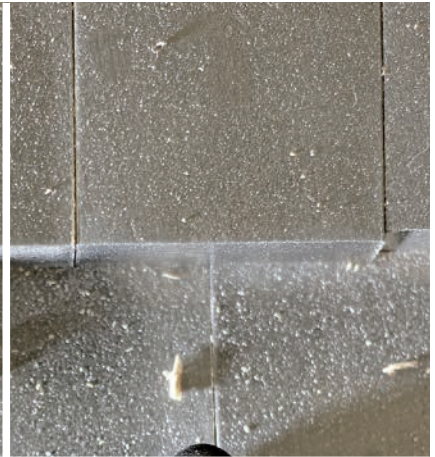



## MINICUT

Bohrungsbearbeitung

grooving, boring and profiling

## Sets

D min. 8 mm

D min. 11 mm

Bestellnummer  
part number

Inhalt  
Content

K10F  
AL41F  
P18C  
CN45F

### SET-MC08-LF/R



Beispielfoto  
exemplary presentation

- Ausdrehen und Kopieren (Rechte Ausführung)
- Stechdrehen (Rechte Ausführung)
- Gewindedrehen (Rechte Ausführung)

- boring and profiling (righthand version)
- grooving (righthand version)
- threading (righthand version)

#### Halter / toolholder:

1 x 608.0016.1E.ST

#### Schneideinsatz / insert:

1 x RS008.0090  
1 x RS08.008R04  
1 x RS08.1846.02  
1 x RS08.3046.02  
1 x RS08.0815.01



Bestellnummer  
part number

Inhalt  
Content

K10F  
AL41F  
P18C  
CN45F

### SET-MC11-LF/R



Beispielfoto  
exemplary presentation

- Ausdrehen und Kopieren (Rechte Ausführung)
- Stechdrehen (Rechte Ausführung)
- Gewindedrehen (Rechte Ausführung)

- boring and profiling (righthand version)
- grooving (righthand version)
- threading (righthand version)

#### Halter / toolholder:

1 x 611.0016.2E.ST

#### Schneideinsatz / insert:

1 x RS011.0090  
1 x RS11.008R04  
1 x RS11.1867.02  
1 x RS11.3067.02  
1 x RS11.1020.01



# MINICUT

Bohrungsbearbeitung

grooving, boring and profiling

## Sets

D min. 14 mm



Bestellnummer  
part number

Inhalt  
Content

K10F  
AL41F  
P18C  
CN45F

### SET-MC14-LF/R



- Ausdrehen und Kopieren (Rechte Ausführung)
- Stechdrehen (Rechte Ausführung)
- Vorstechen und Fasen (Rechte Ausführung)
- Axialstechen (Rechte Ausführung)
- boring and profiling (righthand version)
- grooving (righthand version)
- pregrooving and chamfering (righthand version)
- face grooving (righthand version)

#### Halter / toolholder:

1 x 614.0016.3E.ST

#### Schneideinsatz / insert:

- 1 x RS014.0300
- 1 x RS14.030R15
- 1 x RS14.1867.02
- 1 x RS14.0815.45
- 1 x RS014.1430.52



Bestellbeispiel:  
SET-MC14-LF/R



order example:  
SET-MC14-LF/R

## MINICUT

Bohrungsbearbeitung

grooving, boring and profiling

## Technische Hinweise

Schnittwerte und Anzahl der Schnitte beim Gewindedrehen

Technical instructions, Cutting data and number of passes for threading

## Empfohlene Anzahl der Schnitte

Die Anzahl der Schnitte ist nur ein Richtwert für das Gewindedrehen. Um eine möglichst lange Standzeit der Schneide zu erreichen beachten Sie bitte die Erklärungen für die Zustellung. Leerschnitte zum Fertigschneiden sind in dieser Tabelle nicht berücksichtigt.

### Recommended number of passes

The number of passes is only a recommendation for threading. To reach a good tool life you have to mention the explanation for the infeed. Finishing passes are not considered in that chart.

		Stahl (Festigkeit N/mm <sup>2</sup> ) Steel (N/mm <sup>2</sup> tensile strength)					rostfreier Stahl stainless steel	Guss cast iron	Alumini- um alumini- um
		400-500	500-700	700-850	850-1150	>1150			
V m/min		160	140	120	90	70	90	100	300
Steigung P Pitch P		Anzahl der Schnitte number of passes							
mm	Gg/" TPI								
0,5	48	5	5	5	5	8	8	5	5
0,8	32	6	6	6	6	8	8	6	6
1	24	7	7	7	7	8	8	7	7
1,25	20-19	8	8	8	8	10	10	8	8
1,5	16	10	10	10	10	12	12	10	10
1,75	14	12	12	12	12	14	14	12	12
2	12-11	13	13	13	13	15	15	13	13
2,5	10	15	15	16	16	18	18	16	15
3 - 3,5	8	16	16	17	17	20	20	17	16
4		18	18	19	19	22	22	19	18
5		20	20	21	21	24	24	21	20
6		22	22	23	23	26	26	23	22

## MINICUT

Bohrungsbearbeitung

grooving, boring and profiling

## Technische Hinweise

Gewinde schneiden

Technical instructions,  
threading

## Vorschubrichtung

Mit jedem Schneideinsatz für das Gewindedrehen kann sowohl ein Rechts- wie auch ein Linksgewinde geschnitten werden. Hierbei ist folgende Vorschubrichtung zu beachten:

### Feed direction

Every insert can be used for right- and lefthand thread. You only have to consider the following feed direction:

Rechtsgewinde  
thread right hand

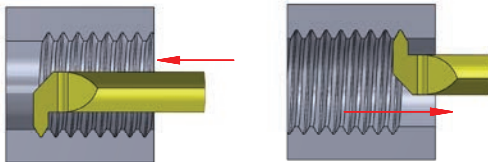

Linksgewinde  
thread left hand

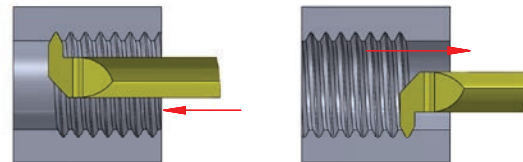

## Zustellungsvarianten

Radiale Zustellung	wechselnde Flankenzustellung	einseitige Flankenzustellung
Die meist verwendete Methode um Gewinde herstellen. Beide Schneiden sind gleichzeitig im Eingriff.	Die Schneiden werden wechselnd eingesetzt.	Nur eine Schneidewird für die komplette Gewindeerstellung eingesetzt.
Problematische Spanbildung, dadurch hohe Schnittkräfte und Verschleiß am Werkzeug und Bauteil.	Reduzierung des Schnittdrucks, höhere Standzeit und bessere Spanbildung.	Reduzierung des Schnittdrucks und bessere Spanbildung, aber einseitige Abnutzung des Werkzeugs.

### Infeed possibilities

Radial infeed	alternating flank infeed	flank infeed
The most used method for threading. both sides are at the same time in process.	The flanks are alternating used	Only one cutting edge is used for the complete thread
Problematic chip education, high cutting force and wearness at insert and work piece	Reduced cutting force, higher state time and chip education	Reduced cutting force and better chip education, but one-sided wearness

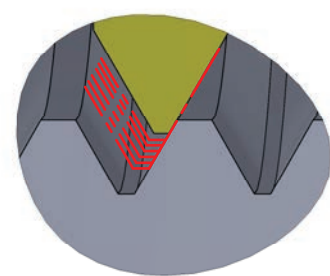
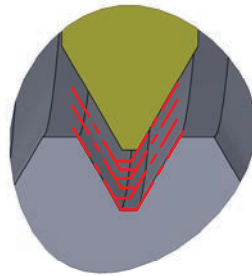
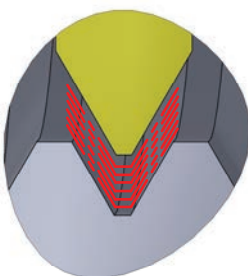

## MINICUT

Bohrungsbearbeitung

grooving, boring and profiling

## Technische Hinweise

Hartmetallsorten und Beschichtungen

Technical instructions,  
carbide grades and coatings

### K10F

Universell einsetzbares Feinkornhartmetall mit guter Verschleißfestigkeit. Unbeschichtet geeignet für Anwendungen mit niedrigen und mittleren Schnittgeschwindigkeiten, sowie die Bearbeitung von Nicht-eisenmetallen.

All purpose micrograin carbide with good abrasion resistance. Uncoated for applications with low or medium cutting speeds and machining of non-ferrous materials.

### CBN

Zähe CBN-Sorte für Anwendungen mit niedrigen Schnittgeschwindigkeiten. Geeignet für gehärtete Stähle, unterbrochene Schnitte und Grauguss.

Ductile CBN grade for applications with lower cutting speed. Suitable for hardened steel, interrupted cuts and cast iron.

### CN45F

Universell einsetzbare PVD-TiN-Beschichtung. Diese Allround-Sorte ist für niedrige und mittlere Schnittgeschwindigkeiten mit Einschränkung bei NE-Metallen

PVD-TiN coating - all purpose, all around grade is suitable for low and medium cutting speed with restrictions on non-ferrous materials.

### AL41F

Sehr universell einsetzbare TiAlN-Beschichtung mit hoher Temperaturbeständigkeit bei hoher Härte. Sehr gut geeignet auch für NE-Metalle.

TiAlN coating - very universal with a high resistance to high temperature and hardness. Very suitable also for non-ferrous metals.

### PD2F

Beschichtung für den universellen Einsatz bei niedrigen und mittleren Schnittgeschwindigkeiten.

Coating for universal use with medium and low speed.

### XC2A

Beschichtung mit einer excellenten Warmhärte, Oxidationsbeständigkeit und thermischen Isolationsfähigkeit. Ideal für Hartzerspannung >60HRC

Coating with excellent hot hardness, high oxidation resistance and thermal insulation capacity. Perfect for hard machining >60 HRC.

## MINICUT

Bohrungsbearbeitung

grooving, boring and profiling

## Technische Hinweise

Hartmetallsorten und Beschichtungen

Technical instructions,  
carbide grades and coatings

### P01C

**Beschichtung für die Bearbeitung in zähen Materialien bei niedrigen und mittleren Schnittgeschwindigkeiten.**

Coating for the processing in tough material with medium or low cutting speed

### P03C

**Beschichtung für die Bearbeitung von schwer zerspanbaren Materialien. Sehr gut auch für die Trockenbearbeitung geeignet.**

Coating for materials which are difficult to machine. Perfect to use for dry machining.

### P07C

**Beschichtung für die Bearbeitung von Titan, Edelstahl und Molybdän.**

Coating to machine titanium, stainless steel and molybdenum.

### P18C

**Universell einsetzbare Hochleistungsschicht mit hoher Oxidationsbeständigkeit, Verschleißfestigkeit und Warmhärte.**

Very universal high performance coating with high oxidation resistance, wear resistance and hot hardness resistance.

### NEME

**Beschichtung für die Bearbeitung von Aluminium, Al-Legierungen, NE-Metallen und Composite-Werkstoffen.**

Coating for machining aluminium, alloys, non-ferrous metals and composite materials.



# MINICUT

Bohrungsbearbeitung

grooving, boring and profiling

# Technische Hinweise

Schnittdaten

Technical instructions,  
cutting data

	Werkstoff	Festigkeit	Werkstoff-Nr	Werkstoffbezeichnung	Werkstoff-Nr
P	Allgemeiner Baustahl	< 800 N/mm2	1.0037	St37-2	1.0570
	Automatenstahl	< 800 N/mm2	1.0718	9SMnPb28	1.0727
	Einsatzstahl unlegiert	< 800 N/mm2	1.0401	C15	1.0481
	Einsatzstahl legiert	< 1000 N/mm2	1.7331	16MnCr5 (EC80)	1.7015
	Vergütungsstahl unlegiert	< 850 N/mm2	1.0503	C45	1.1191
	Vergütungsstahl unlegiert	< 1000 N/mm2	1.0601	C60	1.1221
	Vergütungsstahl legiert	< 800 N/mm2	1.5131	50MnSi4	1.7030
	Vergütungsstahl legiert	< 1300 N/mm2	1.5755	31NiCr14	1.7033
	Stahlguss	< 850 N/mm2	0.9650	G-X260Cr27	1.6750
	Nitrierstahl	< 1000 N/mm2	1.8504	34CrAl6	1.8507
	Nitrierstahl	< 1200 N/mm2	1.8515	31CrMo12	1.8523
	Wälzlagerstahl	< 1200 N/mm2	1.3505	100Cr6 (W3)	1.3543
	Federstahl	< 1200 N/mm2	1.5026	55Si7	1.7176
	Schnellarbeitsstahl	< 1300 N/mm2	1.3344	S 6-5-3	1.3255
	Werkzeugstahl für Kaltarbeit	< 1300 N/mm2	1.2312	40CrMnMoS8 6	1.2379
	Werkzeugstahl für Warmbeit	< 1300 N/mm2	1.2343	X38CrMoV 5 1	1.2767
M	Stahl und Stahlguss rostfrei geschwefelt	< 850 N/mm2	1.4305	X8CrNiS18 9	1.4105
	Nichtrostender Stahl, ferritisch	< 750 N/mm2	1.4510	X3CrTi17	1.4528
	Nichtrostender Stahl, martensitisch	< 900 N/mm2	1.4034	X46Cr13	1.4116
	Nichtrost. Stahl, ferritisch/martensit.	<1100 N/mm2	1.4313	X3CrNi13-4	1.4028
	Nichtrost. Stahl, austenitisch/ferritisch	< 850 N/mm2	1.4460	X8CrNiMo27 5	1.4821
	Nichtrostender Stahl, austenitisch	< 750 N/mm2	1.4301	X5CrNi18-10	1.4571
K	Hitzebeständig	< 1100 N/mm2	1.4747	X80CrNiSi20	1.4876
	Grauguss mit Lammellengraphit	100-350N/mm2	0.6010	GG10	0.6025
	Grauguss mit Lammellengraphit	300-1000N/mm2	0.6030	GG30	0.6045
	Kugelgraphitguss	300-500N/mm2	0.7040	GGG40	0.7050
	Kugelgraphitguss	550-800N/mm2	0.7060	GGG60	0.7080
	Temperguss weis	350-450N/mm2	0.8035	GTW35	0.8045
	Temperguss weis	500-650N/mm2	0.8055	GTW55	0.8065
	Temperguss schwarz	350-450N/mm2	0.8135	GTS35	0.8145
N	Temperguss schwarz	500-700N/mm2	0.8155	GTS55	0.8170
	Aluminium ( unlegiert, niedrig legiert )	< 350 N/mm2	3.0255	Al99,5	3.3308
	Aluminiumlegierungen < 0,5% Si	< 500 N/mm2	3.0515	AlMn1	3.1355
	Aluminiumlegierungen 0,5-10% Si	< 400 N/mm2	3.2152	GD-AlSi6Cu4	3.2373
	Aluminiumlegierungen 10-15% Si	< 400 N/mm2	3.2381	G-AlSi10Mg	3.5562
	Aluminiumlegierungen > 15% Si	< 400 N/mm2		G-AlSi17Cu4	
	Kupfer ( unlegiert, niedrig legiert )	< 350 N/mm2	2.0060	E-Cu57	2.0090
	Kupfer-Knetlegierungen	< 700 N/mm2	2.0240	CuZn15	2.0265
	Kupfer-Sonderlegierungen	< 200 HB	2.0916	CuAl5	2.1525
	Kupfer-Sonderlegierungen	< 300HB	2.0978	CuAl11Ni6Fe5	
	Kupfer-Sonderlegierungen	> 300 HB	2.1247	CuBe2F125	
	Messing kurzspanend, Bronze, Rotguss	< 600 N/mm2	2.0360	CuZn40 (Ms60)	2.0380
	Messing langspanend	< 600 N/mm2	2.0335	CuZn36 (Ms63)	2.1293
	Thermoplaste			Delrin, Hostalen	
	Duroplaste			Ferrozell, Bakelit	
	Faserverstärkte Kunststoffe			GFK (Glasfaserverstärkt )	
	Magnesium und Magnesiumlegierungen	< 850 N/mm2	3.5200	M2, MgMn2	3.5612
	Graphit			C8000, R8500X	
Wolfram und Wolframlegierungen			W-NiFe (Densimet W)		
Molybdän und Molybdänlegierungen			Mo , Mo-50Re		
S	Reinnickel		1.3911	RNi24	1.3927
	Nickellegierungen		1.3912	Ni36 (Invar)	1.3924
	Nickellegierungen	< 850 N/mm2	2.4360	S-NiCu 30 Fe	
	Nickel-Chromlegierungen		2.4886	SG-NiMo16Cr16W	2.4610
	Nickel- und Kobaltlegierungen	< 1300 N/mm2	2.4632	NiCr20Co18Ti	2.4631
	Nickel- und Kobaltlegierungen	< 1300 N/mm2	2.4634	NiCo20Cr15MoAlTi	2.4654
	Hochwarmfeste Legierungen	< 1300 N/mm2		Hardox 400	1.4939
	Nickel-Kobalt-(Chrom-)legierungen	< 1400 N/mm2	2.4806	SG-NiCr20Nb, Inconel 82	2.4851
	Reintitan	< 900 N/mm2	3.7025	Ti99,8	3.7034
	Titanlegierungen	< 700 N/mm2	3.7114	TiAl5Sn2	3.7174
H	Titanlegierungen	< 1200 N/mm2	3.7164	TiAl5V4	3.7144
	Stahl gehärtet	< 45 HRc			
		46-55HRc			
		56-60 HRc			
	61-65 HRc				
	65-70 HRc				

### Vorschub f:

Einstechen: 0,01 - 0,03 mm/U

Kopierendrehen: 0,03 - 0,10 mm/U

Axialstechen: 0,02 - 0,06 mm/U

### feed f:

groove: 0,01-0,03 mm/Rev.

copy turning: 0,03 - 0,10 mm/Rev.

axial groove: 0,02 - 0,06 mm/Rev.

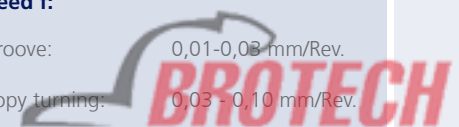

# MINICUT

Bohrungsbearbeitung

grooving, boring and profiling

# Technische Hinweise

Schnittdaten

Technical instructions,  
cutting data



Werkstoffbezeichnung	Werkstoff-Nr	Werkstoffbezeichnung	Vc AL41F (m/min.)
St52-3	1.0060	St60-2	80-200
45S20	1.0757	46SPb2	80-200
17Mn4	1.1141	C15E (CK15)	80-200
13Cr3 (EC60)	1.5919	15CrNi6	80-160
Ck45	1.0535	C55	80-140
Ck60	1.0540	C50	80-160
28Cr4	1.7225	42CrMo4	80-160
34Cr4	1.3565	48CrMo4	80-150
GS-20NiCrMo3 7	1.6582	GS-34 CrNiMo 6	80-200
34AlMo5	1.8509	41CrAlMo7	70-140
39CrMoV19 3	1.8550	34 CrAlNi 7	70-140
X192CrMo17	1.3520	100 CrMn 6 (W4)	70-140
55Cr3	1.7701	51CrMoV4	
S 18-1-2-5	1.3294	PMH56-5-3-8; ASP30	
X155CrVMo12 1	1.2316	X38CrMo16; RAMAX	
X45NiCrMo4	1.2842	90MnCrV8	
X4CrMoS18	1.4107	GX8CrNi12	80-160
X105CrCoMo18 2	1.4016	X6Cr17	80-160
X50CrMoV15	1.4106	X2CrMoSi18-2-1	80-160
X30Cr13	1.4104	X14CrMoS17	20-85
X20CrNiSi25 4	1.4462	X2CrNiMoN22-5-3 (Duplex)	20-75
X6CrNiMoTi17 12 2	1.4449	X3CrNiMo18-12-3	20-65
X10NiCrAlTi32-21	1.4825	GX25CrNiSi18-9	20-65
GG25			30-180
GG45			30-150
GGG50			30-180
GGG80			30-120
GTW45			30-90
GTW65			20-80
GTS45			30-90
GTS70			20-80
Al99,9Mg0,5	3.0256	E-Al H	120-600
AlCuMg2	3.3315	AlMg1	120-600
GD-AlSi9Mg	3.2134	GD-AlSi5Cu1Mg	100-450
G-MgAl6	3.2525	S-AlSi12	70-300
G-AlSi25CuNiMg		G-AlSi21CuNiMg	60-150
SF-Cu	2.1522	CuSi2Mn	60-150
CuZn30	2.0321	CuZn37	100-180
CuSi3Mn		Ampco 8-16	90-180
		Ampco 18-26	80-180
		Ampco M-4	80-180
CuZn39Pb2 (Ms58)	2.0410	CuZn44Pb2	120-220
CuCrZr	2.1080	CuSn6Zn6	70-150
Makrolon, Novodur		Acrylglas, Polystyrol	80-180
Pertinax		Resopal	
CFK (Kohlefaserverstärkt)		AFK (Amidfaserverstärkt)	
MgAl6Zn1	3.5812	MgAl8Zn1	
R8650		Technograph15	
W-Cu80/20		W93NiFe (DENAL)	
TZC, TZM		MHC, ODS	
RNi8	1.3926	RNi12	30-80
Ni54	1.3921	Ni49	18-75
NiCu 30 Fe		Monel 400	18-75
NiMo16Cr16Ti		Hastelloy C-276	40-70
NiCr20TiAl		Nimonic 80	40-70
NiCr19Co14Mo4Ti		Waspaloy	40-70
X12CrNiMo12	1.4980	X6NiCrTiMoVB25-15-2	40-70
NiCr23Fe, Inconel 601	2.4667	SG-NiCr19NbMoTi	40-70
Ti99,7	3.7064	Ti99,5	40-70
TiAl6V6Sn2	3.7124	TiCu2	40-70
TiAl6Sn2Zr4Mo2	3.7154	TiAl6Zr5	40-70

**Vorschub f:**

Einstechen: 0,01 - 0,03 mm/U  
 Kopierendrehen: 0,03 - 0,10 mm/U  
 Axialstechen: 0,02 - 0,06 mm/U

**feed f:**

groove: 0,01-0,03 mm/Rev.  
 copy turning: 0,03 - 0,10mm/Rev.  
 axial groove: 0,02 - 0,06 mm/Rev.

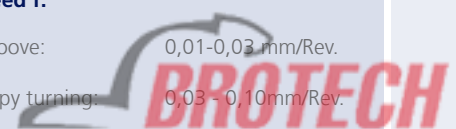



# MINICUT

Bohrungsbearbeitung

grooving, boring and profiling

# Technische Hinweise

Schnittdaten

Technical instructions,  
cutting data

	MATERIAL	STRENGTH (psi)	MATERIAL NUMBER	MATERIAL DESCRIPTION	ANSI
P	General Construction Steel	< 116030	1.0037	St37-2	A284
	Free-cutting steel	< 116030	1.0718	95MnPb28	12L13
	Non-Alloyed Steel	< 116030	1.0401	C15	1015
	Alloy Steel	< 145038	1.7331	16MnCr5 (EC80)	5120
	Compensation Steel Unalloyed	< 123282	1.0503	C45	1045
	Compensation Steel Unalloyed	< 145038	1.0601	C60	1060
	Alloy Steel	< 116030	1.5131	50MnSi4	
	Alloy Steel	< 188549	1.5755	31NiCr14	
	Cast Steel	< 123282	0.9650	G-X260Cr27	
	Nitriding Steel	< 145038	1.8504	34CrAl6	
	Nitriding Steel	< 174045	1.8515	31CrMo12	
	Bearing Steel	< 174045	1.3505	100Cr6 (W3)	52100
	Bearing Steel	< 174045	1.5026	55Si7	-
	High Speed Steel	< 188549	1.3344	S 6-5-3	
	Tool Steel for Cold Work	< 188549	1.2312	40CrMnMoS8 6	
	Tool Steel for Warm Work	< 188549	1.2343	X38CrMoV 5 1	H11
M	Steel and cast steel rostfei sulfurized	< 123282	1.4305	X8CrNiS18 9	303
	Stainless Steel, Ferritic	< 108778	1.4510	X3CrTi17	
	Stainless Steel, Martensitic	< 130534	1.4034	X46Cr13	-
	Non-rusting. Steel, Ferritic / Martensite	< 159542	1.4313	X3CrNi13-4	
	Non-rusting. Steel, Austenitic / Ferritic	< 123282	1.4460	X8CrNiMo27 5	S32900
	Stainless Steel, Austenitic	< 108778	1.4301	X5CrNi18-10	304
K	Heat Resistant	< 159542	1.4747	X80CrNiSi20	
	Gray Cast Iron with Lamellar Graphite	14504-50763	0.6010	GG10	CLASS20
	Gray Cast Iron with Lamellar Graphite	43511-145038	0.6030	GG30	CLASS45
	Ball Graphite Castings	43511-72519	0.7040	GGG40	60-40-18
	Ball Graphite Castings	79771-116030	0.7060	GGG60	-
	Malleable Cast Iron	50763-65367	0.8035	GTW35	-
	Malleable Cast Iron	72519-94274	0.8055	GTW55	-
	Malleable Cast Iron Black	50763-65267	0.8135	GTS35	32510
N	Malleable Cast Iron Black	72519-101526	0.8155	GTS55	50005
	Aluminum ( unalloyed, low alloy )	< 50763	3.0255	Al99,5	1000
	Aluminum Alloys < 0,5%	< 72519	3.0515	AlMn1	
	Aluminum Alloys 0,5-10%	< 58015	3.2152	GD-AlSi6Cu4	
	Aluminum Alloys 10-15%	< 58015	3.2381	G-AlSi10Mg	-
	Aluminum Alloys > 15%	< 58015		G-AlSi17Cu4	
	Copper (unalloyed, low alloy)	< 50763	2.0060	E-Cu57	
	Copper Wrought Alloys	< 101526	2.0240	CuZn15	C23000
	Copper Special Alloys	< 200 HB	2.0916	CuAl5	
	Copper Special Alloys	< 300HB	2.0978	CuAl11Ni6Fe5	
	Copper Special Alloys	> 300 HB	2.1247	CuBe2F125	
	Brass Short-Spanning, Bronze, Gunmetal	< 87023	2.0360	CuZn40 (Ms60)	C28000
	Brass Long-Spanning	< 87023	2.0335	CuZn36 (Ms63)	C36000, C48200
	Thermoplastics			Delrin, Hostalen	
	Thermosets			Ferrozell, Bakelit	
	Fiber Reinforced Plastics			GFK (Glasfaserverstärkt )	
	Magnesium and Magnesium Alloys	< 123282	3.5200	M2, MgMn2	
	Graphite			C8000, R8500X	
	Tungsten and Tungsten Alloys			W-NiFe (Densimet W)	
	Molybdenum and Molybdenum Alloys			Mo , Mo-50Re	
S	Pure Nickel		1.3911	RNi24	
	Nickel Alloys		1.3912	Ni36 (Invar)	
	Nickel Alloys	< 123282	2.4360	S-NiCu 30 Fe	
	Nickel-Chromium Alloy		2.4886	SG-NiMo16Cr16W	
	Nickel and Cobalt Alloys	< 188549	2.4632	NiCr20Co18Ti	
	Nickel and Cobalt Alloys	< 188549	2.4634	NiCo20Cr15MoAlTi	
	High-Temperature Resistant Alloys	< 188549		Hardox 400	
	Nickel-Cobalt-(Chrom-) Alloys	< 203053	2.4806	SG-NiCr20Nb, Inconel 82	
	Pure Titanium	< 130534	3.7025	Ti99,8	
	Titanium Alloys	< 101526	3.7114	TiAl5Sn2	-
	Titanium Alloys	< 174045	3.7164	TiAl5V4	
H	Hardened Steel	< 45 HRC			
		46-55HRC			
		56-60 HRC			
		61-65 HRC			
	65-70 HRC				

Data on this page is for reference and planning only. Materials and processes should be tested in your environment to achieve desired results.

feed f:

groove: 0.0004 - 0.0012 in/Rev.

copy turning: 0.0012 - 0.0039 in/Rev.

axial groove: 0.0008 - 0.0024 in/Rev.

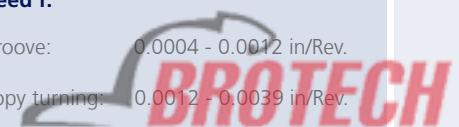

# MINICUT

Bohrungsbearbeitung

grooving, boring and profiling

# Technische Hinweise

Schnittdaten

Technical instructions,  
cutting data



MATERIAL NUMBER	MATERIAL DESCRIPTION	ANSI	MATERIAL NUMBER	MATERIAL DESCRIPTION	ANSI	AL41F (SFM)
1.0570	St52-3		1.0060	St60-2	A572	262-656
1.0727	45S20		1.0757	46SPb2		262-656
1.0481	17Mn4		1.1141	C15E (CK15)	1015	262-656
1.7015	13Cr3 (EC60)		1.5919	15CrNi6	3115	262-525
1.1191	Ck45	1045	1.0535	C55	1055	262-459
1.1221	Ck60	1060	1.0540	C50		262-525
1.7030	28Cr4		1.7225	42CrMo4	4140	262-525
1.7033	34Cr4	5132	1.3565	48CrMo4		262-492
1.6750	GS-20NiCrMo3 7		1.6582	GS-34 CrNiMo 6	4337	262-656
1.8507	34AlMo5		1.8509	41CrAlMo7	A355	230-459
1.8523	39CrMoV19 3		1.8550	34 CrAlNi 7		230-459
1.3543	X192CrMo17		1.3520	100 CrMn 6 (W4)		230-459
1.7176	55Cr3	5155	1.7701	51CrMoV4		
1.3255	S 18-1-2-5	1015	1.3294	PMH56-5-3-8; ASP30		
1.2379	X155CrVMo12 1	D2	1.2316	X38CrMo16; RAMAX		
1.2767	X45NiCrMo4		1.2842	90MnCrV8	02	
1.4105	X4CrMoS18	430F	1.4107	GX8CrNi12		262-525
1.4528	X105CrCoMo18 2		1.4016	X6Cr17	430	262-525
1.4116	X50CrMoV15		1.4106	X2CrMoSi18-2-1		262-525
1.4028	X30Cr13	420F	1.4104	X14CrMoS17	430 F	66-279
1.4821	X20CrNiSi25 4		1.4462	X2CrNiMoN22-5-3 (Duplex)	UNS31803	66-246
1.4571	X6CrNiMoTi17 12 2	316 Ti	1.4449	X3CrNiMo18-12-3	317	66-213
1.4876	X10NiCrAlTi32-21	B163	1.4825	GX25CrNiSi18-9		66-213
0.6025	GG25	A48-40 B				98-591
0.6045	GG45					98-492
0.7050	GGG50	65-45-12				98-591
0.7080	GGG80	120-90-02				98-394
0.8045	GTW45					98-295
0.8065	GTW65					66-262
0.8145	GTS45					98-295
0.8170	GTS70					66-262
3.3308	Al99,9Mg0,5		3.0256	E-Al H		394-1968
3.1355	AlCuMg2	2024	3.3315	AlMg1		394-1968
3.2373	GD-AlSi9Mg		3.2134	GD-AlSi5Cu1Mg		328-1476
3.5562	G-MgAl6		3.2525	S-AlSi12		230-984
	G-AlSi25CuNiMg			G-AlSi21CuNiMg		197-492
2.0090	SF-Cu		2.1522	CuSi2Mn		197-492
2.0265	CuZn30		2.0321	CuZn37		328-591
2.1525	CuSi3Mn			Ampco 8-16		295-591
				Ampco18-26		262-591
				Ampco M-4		262-591
2.0380	CuZn39Pb2 (Ms58)		2.0410	CuZn44Pb2		394-722
2.1293	CuCrZr		2.1080	CuSn6Zn6		230-492
	Makrolon, Novodur			Acrylglas, Polystyrol		262-591
	Pertinax			Resopal		
	CFK (Kohlefaserverstärkt)			AFK (Amidfaserverstärkt)		
3.5612	MgAl6Zn1		3.5812	MgAl8Zn1		
	R8650			Technograph15		
	W-Cu80/20			W93NiFe (DENAL)		
	TZC, TZM			MHC , ODS		
1.3927	RNi8		1.3926	RNi12		98-262
1.3924	Ni54		1.3921	Ni49		59-246
	NiCu 30 Fe			Monel 400		59-246
2.4610	NiMo16Cr16Ti			Hastelloy C-276		131-230
2.4631	NiCr20TiAl			Nimonic 80		131-230
2.4654	NiCr19Co14Mo4Ti			Waspaloy		131-230
1.4939	X12CrNiMo12	904L	1.4980	X6NiCrTiMoVB25-15-2		131-230
2.4851	NiCr23Fe, Inconel 601		2.4667	SG-NiCr19NbMoTi		131-230
3.7034	Ti99,7		3.7064	Ti99,5		131-230
3.7174	TiAl6V6Sn2		3.7124	TiCu2		131-230
3.7144	TiAl6Sn2Zr4Mo2		3.7154	TiAl6Zr5		131-230

Data on this page is for reference and planning only. Materials and processes should be tested in your environment to achieve desired results.

feed f:

groove: 0.0004 - 0.0012 in/Rev.

copy turning: 0.0012 - 0.0039 in/Rev.

axial groove: 0.0008 - 0.0024 in/Rev.

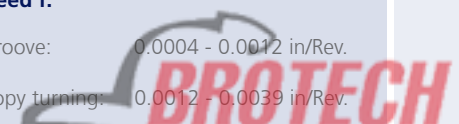



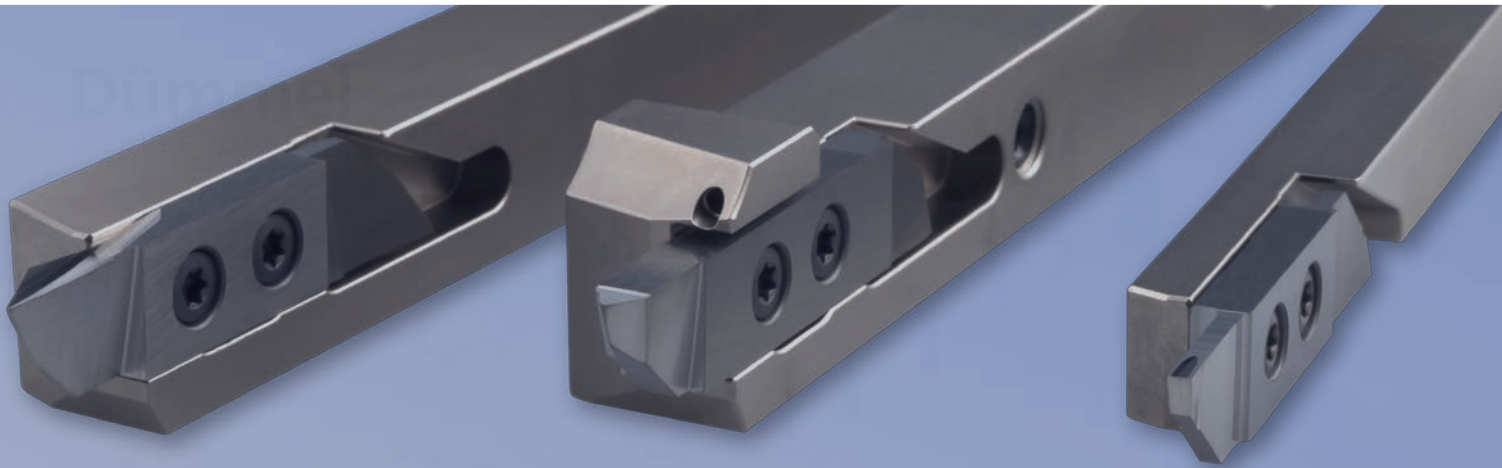

 **Dümmel**<sup>®</sup>  
WERKZEUGFABRIK

## SWISSLINE



Miniatúraußenbearbeitung,  
zweischneidig

miniature external machining,  
two cutting edges

 **BROTECH**

## SWISSLINE

Miniatúraußenbearbeitung,  
zweischneidig

miniature external machining,  
two-cutting edges

## Übersicht

summary

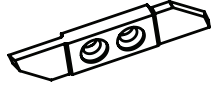

Allgemeine Beschreibung

general instructions

... 187

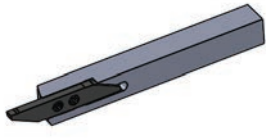

**Klemmhalter**

**toolholder**

**Maße  
dimensions**

**Seite  
page**

**Typ R/L HW10**

Klemmhalter

toolholder

... 188

**Typ R/L HW15**

Klemmhalter  
mit Innenkühlung

toolholder  
with internal cooling

... 189

**Typ R/L HW20**

Klemmhalter,  
abgesetzte Version

toolholder,  
offset version

... 190



**Schneidplattenhalter  
für Rückseitenbearbeitung  
auf Langdrehautomaten**

**toolholder  
for rear end machining  
on Swiss type lathes**

**Maße  
dimensions**

**Seite  
page**

**Typ UMHV**

Schneidplattenhalter

toolholder

... 191

## SWISSLINE

Miniaturaußenbearbeitung,  
zweischneidig

miniature external machining,  
two-cutting edges

## Übersicht

summary

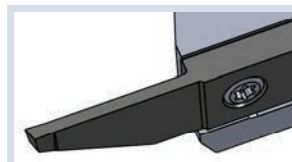

**Wendeschneidplatten**  
**Abstechen**

**indexable inserts**  
**parting off**

**Maße**  
**dimensions**

**Seite**  
**page**

<b>Typ R/L ZW10</b>	Abstechen	parting off	t max. = 6 - 16 b = 0.8 - 3	... 192
<b>Typ R/L ZW11</b>	Abstechen, Schneide versetzt	parting off, offset cutting edge	t max. = 6 - 16 b = 0.8 - 3	... 193
<b>Typ R/L ZW12</b>	Abstechen mit Gegenspindel	parting off with counter spindle	t max. = 6 b = 0.8 / 1.2	... 194
<b>Typ R/L ZW13</b>	Abstechen mit Gegenspindel, Schneide versetzt	parting off with counter spindle, offset cutting edge	t max. = 6 b = 0.8 / 1.2	... 195
<b>Typ R/L ZW14</b>	Abstechen, mit Spanformer	parting off, with chip former	t max. = 8 - 16 b = 1.5 - 3	... 196
<b>Typ R/L ZW15</b>	Abstechen, Schneide versetzt, mit Spanformer	parting off, offset cutting edge, with chip former	t max. = 8 - 16 b = 1.5 - 3	... 197
<b>Typ R/L ZW16</b>	Abstechen, mit Spantreppe	parting off, with chip breaker	t max. = 8 - 16 b = 1.5 - 3	... 198
<b>Typ R/L ZW17</b>	Abstechen, Schneide versetzt, mit Spantreppe	parting off, offset cutting edge, with chip breaker	t max. = 8 - 16 b = 1.5 - 3	... 199
<b>Typ R/L ZW18</b>	Abstechen unter 0°, mit Spanformer	parting off with 0°, with chipformer	t max. = 10 - 16 b = 1.5 - 3	... 200
<b>Typ R/L ZW19</b>	Abstechen unter 0°, mit Spantreppe	parting off with 0°, with chip breaker	t max. = 10 - 16 b = 1.5 - 3	... 201
<b>Typ R/L ZW1A</b>	Abstechen, mit gesintertem Spanformer	parting off, with sintered chipformer	t max. = 10 b = 2	... 202
<b>Typ R/L ZW1B</b>	Abstechen, Schneide versetzt, mit gesintertem Spanformer	parting off, offset cutting edge, with sintered chipformer	t max. = 10 b = 2	... 203
<b>Typ R/L ZW1C</b>	Abstechen unter 0°, mit gesintertem Spanformer	parting off with 0°, with sintered chip former	t max. = 10 b = 2	... 204

## SWISSLINE

Miniatúraußenbearbeitung,  
zweischneidig

miniature external machining,  
two-cutting edges

## Übersicht

summary

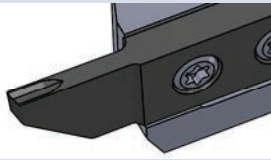

### Wendeschneidplatten Drehen und Abstechen

### indexable inserts turning and parting off

### Maße dimensions

### Seite page

<b>Typ R/L ZW20</b>	Drehen und Abstechen, Wipergeometrie	turning and parting off, wiper geometry	t max. = 10 b = 2	... 205
<b>Typ R/L ZW21</b>	Drehen und Abstechen, Schneide versetzt, Wipergeometrie	turning and parting off, offset cutting edge, wiper geometry	t max. = 10 b = 2	... 206
<b>Typ R/L ZW22</b>	Drehen und Abstechen, mit Spanformer, Wipergeometrie	turning and parting off, with chipformer, wiper geometry	t max. = 10 b = 2	... 207
<b>Typ R/L ZW23</b>	Drehen und Abstechen, Schneide versetzt, mit Spanformer, Wipergeometrie	turning and parting off, offset cutting edge, with chipformer, wiper geometry	t max. = 10 b = 2	... 208

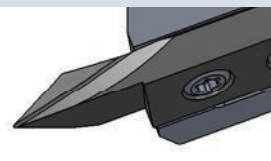

### Wendeschneidplatten Drehen

### indexable inserts turning

### Maße dimensions

### Seite page

<b>Typ R/L ZW30</b>	Vornedrehen	turning in front	t max. = 8 b = 3.4	... 209
<b>Typ R/L ZW31</b>	Vornedrehen, mit Spanformer, Wipergeometrie	turning in front, with chipformer, wiper geometry	t max. = 8 b = 3.4	... 210
<b>Typ R/L ZW40</b>	Kopierdrehen vorne, Schneide versetzt, mit Spanformer	profiling in front, offset cutting edge, with chipformer	t max. = 11 b = 3.2	... 211
<b>Typ R/L ZW41</b>	Kopierdrehen hinten, mit Spanformer	profiling at the back, with chipformer	t max. = 11 b = 3.2	... 212
<b>Typ R/L ZW50</b>	Hintendrehen, Wipergeometrie	turning at the back, wiper geometry	t max. = 6 - 8 b = 0.8 - 1.8	... 213
<b>Typ R/L ZW51</b>	Kopierdrehen hinten, mit Spanformer, Wipergeometrie	profiling at the back, with chip former, wiper geometry	t max. = 6 b = 0.5	... 214
<b>Typ R/L ZW52</b>	Hintendrehen, mit Spantreppe	turning at the back, with chip breaker	t max. = 4.5 b = 0.8	... 215
<b>Typ R/L ZW60</b>	Einstechen und Längsdrehen	grooving and turning	t max. = 2.5 - 6 b = 1 - 3	... 216
<b>Typ R/L ZW61</b>	Einstechen und Längsdrehen, mit Spantreppe	grooving and turning, with chip breaker	t max. = 2.5 - 6 b = 0.8 - 3	... 217



## SWISSLINE

Miniaturaußenbearbeitung,  
zweischneidig

miniature external machining,  
two-cutting edges

## Übersicht

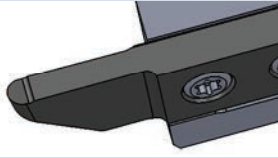
summary

	<b>Wendeschneidplatten Stechdrehen</b>	<b>indexable inserts grooving</b>	<b>Maße dimensions</b>	<b>Seite page</b>
<b>Typ R/L ZW70</b>	Stechdrehen, Vollradius mit Spantreppe	grooving, full radius with chip breaker	t max. = 2 - 16 b = 0.5 - 3.0	... 218
	<b>Wendeschneidplatten Gewindedrehen</b>	<b>indexable inserts threading</b>	<b>Maße dimensions</b>	<b>Seite page</b>
<b>Typ R/L ZW90</b>	Gewindedrehen, Vollprofil, 60°	threading, full profile, 60°	M1 - M4.5 P = 0.25 - 0.75	... 219
<b>Typ R/L ZW90</b>	Gewindedrehen, Vollprofil, 60°	threading, full profile, 60°	M5 - M27 P = 0.8 - 3.0	... 220
<b>Typ R/L ZW94</b>	Gewindedrehen, Teilprofil, 55° / 60°	threading, partial profile, 55° / 60°	P = 0.25 - 2.0	... 221

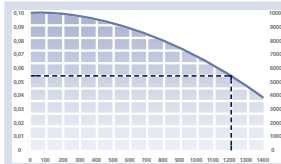

### Technische Hinweise

### Technical Instructions

Seite  
page

Beschreibung der  
Schneidenausführungen

Description of the cutting types

... 222

Allgemeine Informationen zum  
Gewindeschneiden

General informations about threading

... 223

Hartmetallsorten und Beschichtungen

carbide grade and coatings

... 225

Schnittdaten

cutting data

... 227



## SWISSLINE

Miniatúraußenbearbeitung,  
zweischneidig

miniature external machining,  
two-cutting edges

## Allgemeine Beschreibung

general instruction

### Swissline

Unser Programm Swissline bietet ein Stech-Drehwerkzeug für Langdrehautomaten mit einem Stangendurchlass von maximal 32 mm. Schneiden für das Abstechen, Stechdrehen, Überdrehen, Kopierdrehen und Gewindeschneiden sind im Standard verfügbar. Ein breites Angebot von geschliffenen Haltern mit veredelter Oberfläche und Schaftquerschnitten von 8 - 25 mm runden das Programm ab.

#### Swissline

A turn and parting off tool system for Swiss type lathes up to  $\varnothing$  32 mm. Inserts for parting off, grooving, turning, profiling and threading are in standard available. A wide range of refined tool holders and shank sizes between 8 - 25 mm completes our product line.

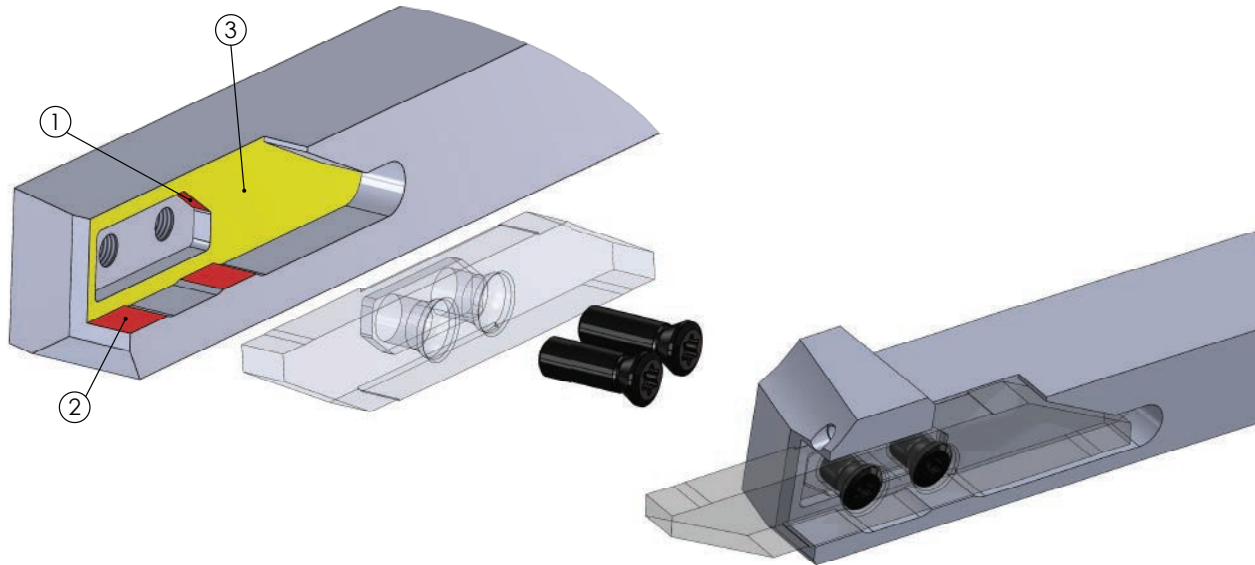

Vorteile:	Advantages:
Große Auswahl an Schneidgeometrien mit speziellen Spanleitstufen für die Bearbeitung	Large selection of insert geometries with different chip breaker geometries
Exakte Positionierung durch 2 Schrauben mit Anschlag (1 + 2) für die axiale Ausrichtung	Special chip breaker design for machining of small- to mid-sized work pieces
Die große Auflagefläche garantiert eine senkrechte Ausrichtung (3)	Perpendicularity guaranteed by two fixing screws, large support face and a genuine stop face for axial positioning
Schnittkräfte werden direkt von der Wendepatte auf den Halter übertragen, sodass keine Abscherkräfte auf die Schrauben wirken	The cutting forces are transferred directly from the insert to the holder; the screws are therefore not exposed to shear stress
Wendeschneidplatten bedingt nachschleifbar	limited regrinding possibility
Bei Schneidenbruch ist die zweite intakte Schneide trotzdem einsetzbar	If first cutting edge has crashed the second is still usable

# SWISSLINE

Miniatöraußenbearbeitung,  
zweischneidig

miniature external machining,  
two-cutting edges

# Typ HW10

Klemmhalter

toolholder

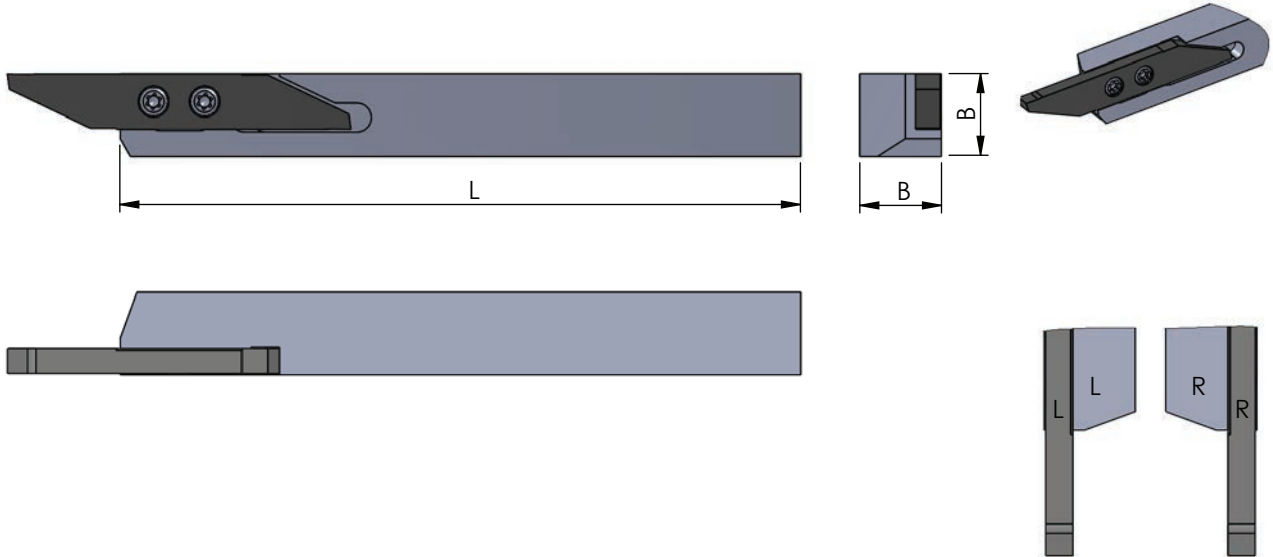

Rechts (R): wie gezeichnet  
Links (L): spiegelbildlich

Rechte Schneidpl. in rechtem Halter  
Linke Schneidpl. in linkem Halter

Abmessungen in mm

righthand version (R): as shown  
lefthand version (L): mirror image

use RH insert in RH tool holder and  
LH insert in LH tool holder

dimensions in mm

Bestellnummer part number	B	B (Zoll / inch)	L	Spanschraub screw	Schraubenschlüssel wrench	Anzugs- drehmoment torque	für Schneidplatte for insert
R/L HW10.0808080	8		80	M3/7-SL	Torx T8	1.2 Nm	R/L ZW...
R/L HW10.0808100	8		100				
R/L HW10.1010080	10		80				
R/L HW10.1010100	10		100				
R/L HW10.1212100	12		100				
R/L HW10.1616125	16		125				
R/L HW10.2020125	20		125				
R/L HW10.2525150	25		150	M3/9-SL	Torx T8	1.2 Nm	
R/L HW10.Z0909080	9.525	3/8"	80				
R/L HW10.Z0909100	9.525	3/8"	100				
R/L HW10.Z1212100	12.7	1/2"	100				
R/L HW10.Z1515125	15.875	5/8"	125				
R/L HW10.Z1919125	19.05	3/4"	125				

Bestellbeispiel:  
für rechte Ausführung  
RHW10.0808080

order example:  
righthand version  
RHW10.0808080



## SWISSLINE

Miniatúraußenbearbeitung,  
zweischneidig

miniature external machining,  
two-cutting edges

## Typ HW15

Klemmhalter  
mit Innenkühlung

toolholder  
with internal cooling

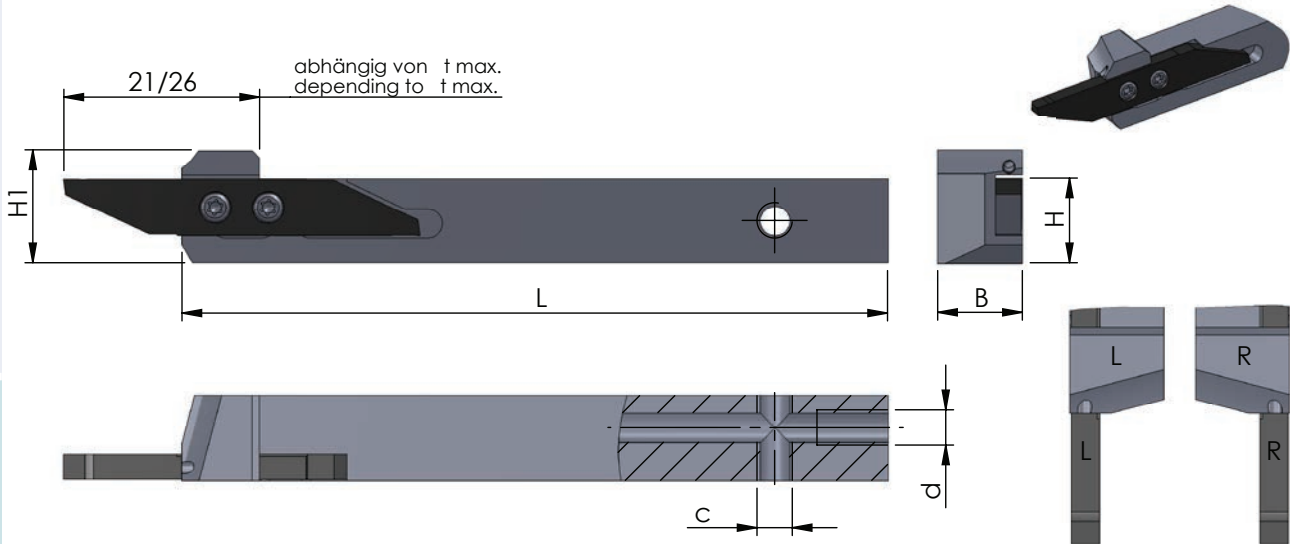

Rechts (R): wie gezeichnet  
Links (L): spiegelbildlich

Rechte Schneidpl. in rechtem Halter  
Linke Schneidpl. in linkem Halter

Abmessungen in mm

righthand version (R): as shown  
lefthand version (L): mirror image

use RH insert in RH tool holder and  
LH insert in LH tool holder

dimensions in mm

Bestellnummer part number	B	B (Zoll / inch)	H	H (Zoll / inch)	L	H1	c	d	Spannschraub screw	Schraubenschlüssel wrench	Anzugs- drehmoment torque	für Schneidplatte for insert
R/L HW15.1208100	12		8		100	12.2	M5	M5	M3/9-SL	Torx T8	1.2 Nm	R/L ZW. ...
R/L HW15.1210100	12		10		100	14	M5	M5				
R/L HW15.1212100	12		12		100	16	M5	M5				
R/L HW15.1616125	16		16		125	20	M5	G1/8"				
R/L HW15.2020125	20		20		125	24	M5	G1/8"				
R/L HW15.2525125	25		25		125	29	M5	G1/8"				
R/L HW15.Z0909100	9.525	3/8"	9.525	3/8"	100	13.5	M5	M5				
R/L HW15.Z1212100	12.7	1/2"	12.7	1/2"	100	16.7	M5	M5				
R/L HW15.Z1515125	15.875	5/8"	15.875	5/8"	125	19.9	M5	G1/8"				
R/L HW15.Z1919125	19.05	3/4"	19.05	3/4"	125	23	M5	G1/8"				

Lieferumfang:  
Halter ohne Kühlmittelanschluss

Bestellbeispiel:  
für rechte Ausführung  
RHW15.1208100

Scope of delivery:  
Holder without coolant connector

order example:  
righthand version  
RHW15.1208100

## SWISSLINE

Miniaturaußenbearbeitung,  
zweischneidig

miniature external machining,  
two-cutting edges

## Typ HW20

Klemhalter,  
abgesetzte Version

toolholder,  
offset version

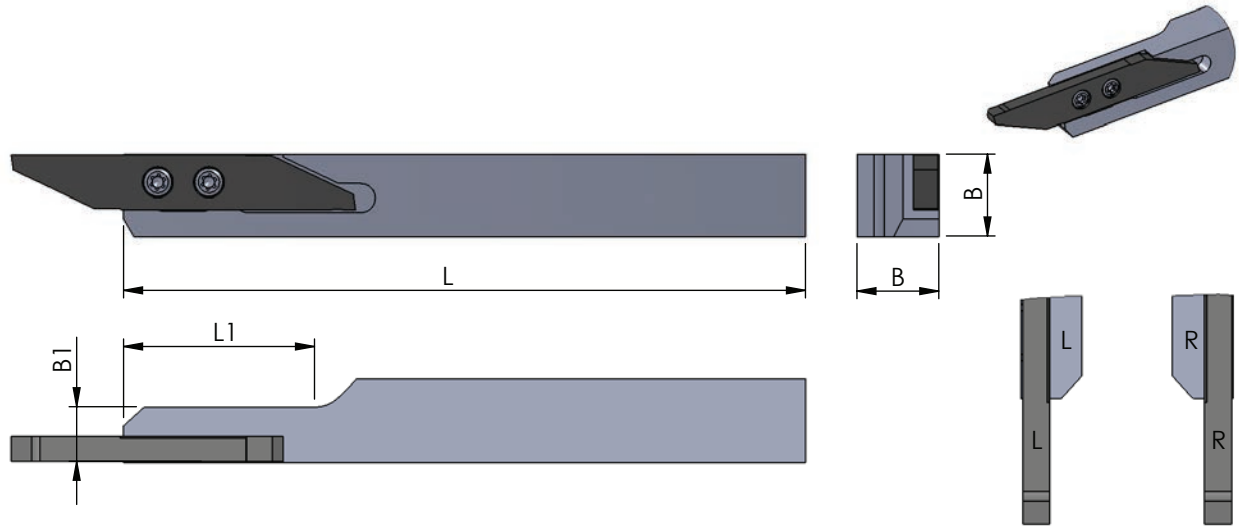

Rechts (R): wie gezeichnet  
Links (L): spiegelbildlich

Rechte Schneidpl. in rechtem Halter  
Linke Schneidpl. in linkem Halter

Abmessungen in mm

righthand version (R): as shown  
lefthand version (L): mirror image

use RH insert in RH tool holder and  
LH insert in LH tool holder

dimensions in mm



Bestellnummer part number	B	B (Zoll / inch)	L	L1	B1	Spannschraub screw	Schraubenschlüssel wrench	Anzugs- drehmoment torque	für Schneidplatte for insert
R/L HW20.1010080	10		80	28	8	M3/7-SL	Torx T8	1.2 Nm	R/L ZW. ...
R/L HW20.1010100	10		100	28	8				
R/L HW20.1212100	12		100	28	8				
R/L HW20.1616125	16		125	28	8				
R/L HW20.Z0909080	9.525	3/8"	80	28	8				
R/L HW20.Z0909100	9.525	3/8"	100	28	8				
R/L HW20.Z1212100	12.7	1/2"	100	28	8				
R/L HW20.Z1515125	15.875	5/8"	125	28	8				

Bestellbeispiel:  
für rechte Ausführung  
RHW20.1010080

order example:  
righthand version  
RHW20.1010080

## SWISSLINE

Miniaturaußenbearbeitung,  
zweischneidig

miniature external machining,  
two-cutting edges

## Typ UMHV

Schneidplattenhalter  
für Rückseitenbearbeitung  
auf Langdrehautomaten

toolholder  
for rear end machining  
on Swiss type lathes

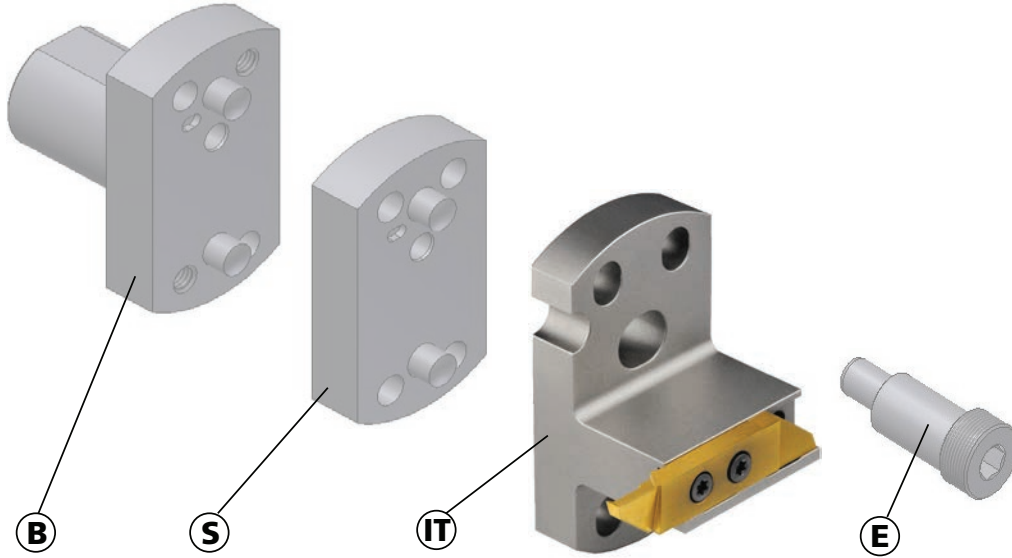

Klemmhalter für rechte und linke  
Schneideinsätze einsetzbar

toolholder for right and left  
inserts usable

Abmessungen in mm

dimensions in mm

Bestellnummer part number	Position	Bezeichnung description	Schneideinsatz insert
UMHV-I0201SWISSRL	IT	Schneidplattenhalter / toolholder	RL ZW...
auf Anfrage / on request	B	Grundhalter / basic toolholder	
auf Anfrage / on request	S	Zwischenplatte / spacer	
auf Anfrage / on request	E	Excenter / excenter	

Bestellbeispiel:  
UMHV-I0201SWISSRL

## SWISSLINE

Miniatöraußenbearbeitung,  
zweischneidig

miniature external machining,  
two-cutting edges

## Typ ZW10

Wendeschneidplatten,  
zum Abstechen

indexable inserts  
for parting off

Stechtiefe  $t$  max. = 6 - 16 mm  
Stechbreite  $b$  = 0.8 - 3.0 mm

depth of groove  $t$  max. = 6 - 16 mm  
width of groove  $b$  = 0.8 - 3.0 mm

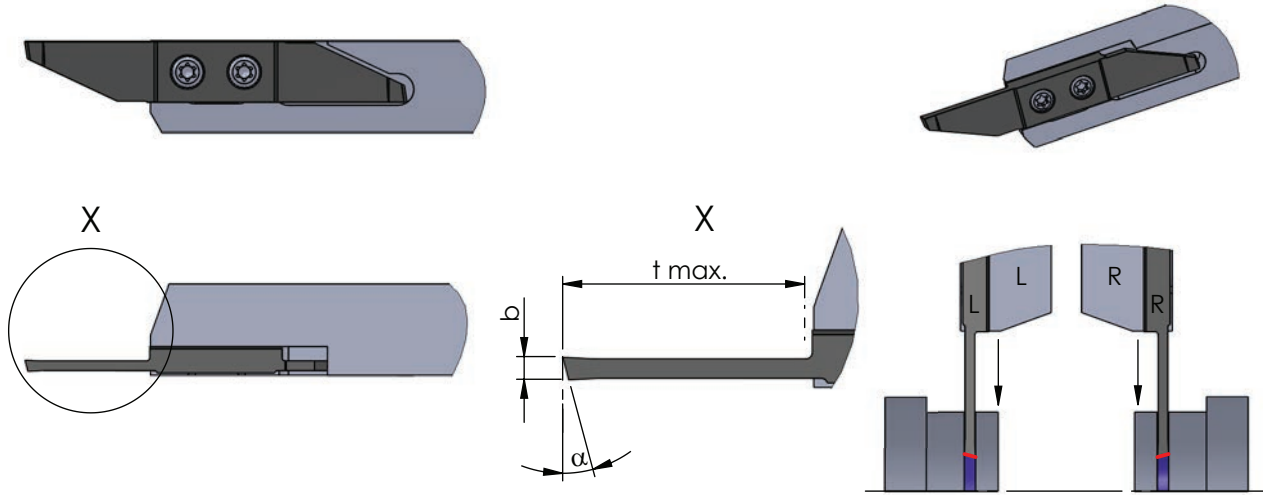

Rechts (R): wie gezeichnet  
Links (L): spiegelbildlich

Rechte Schneidpl. in rechtem Halter  
Linke Schneidpl. in linkem Halter

Abmessungen in mm

righthand version (R): as shown  
lefthand version (L): mirror image

use RH insert in RH tool holder and  
LH insert in LH tool holder

dimensions in mm

Bestellnummer part number	b	t max.	$\alpha$	Klemmhalter Typ toolholder type			
				K10F	CN45F	AL41F	P18C
R/L ZW10.08061500	0.8	6	15°	●			●
R/L ZW10.08101500	0.8	10	15°	●			●
R/L ZW10.10061500	1.0	6	15°	●			●
R/L ZW10.10131500	1.0	13	15°	●			●
R/L ZW10.12061500	1.2	6	15°	●			●
R/L ZW10.15081500	1.5	8	15°	●			●
R/L ZW10.15161500	1.5	16	15°	●			●
R/L ZW10.18081500	1.8	8	15°	●			●
R/L ZW10.20101500	2.0	10	15°	●			●
R/L ZW10.20161500	2.0	16	15°	●			●
R/L ZW10.25131500	2.5	13	15°	●			●
R/L ZW10.25161500	2.5	16	15°	●			●
R/L ZW10.30161500	3.0	16	15°	●			●

Weitere HM Sorten können Sie in der Sorten-  
übersicht im Kapitel "Technische Hinweise" und  
der Preisliste finden.

Bestellbeispiel:  
für rechte Ausführung und Sorte  
RZW10.08061500/P18C

More carbide grades you can find in the grades  
summary in the chapter "technical instructions"  
and in the price list.

order example:  
righthand version and grade  
RZW10.08061500/P18C

## SWISSLINE

Miniatúraußenbearbeitung,  
zweischneidig

miniature external machining,  
two-cutting edges

## Typ ZW11

Wendeschneidplatten,  
zum Abstechen,  
Schneide versetzt

indexable inserts,  
for parting off,  
offset cutting edge

Stechtiefe  $t$  max. = 6 - 16 mm  
Stechbreite  $b$  = 0.8 - 3.0 mm

depth of groove  $t$  max. = 6 - 16 mm  
width of groove  $b$  = 0.8 - 3.0 mm

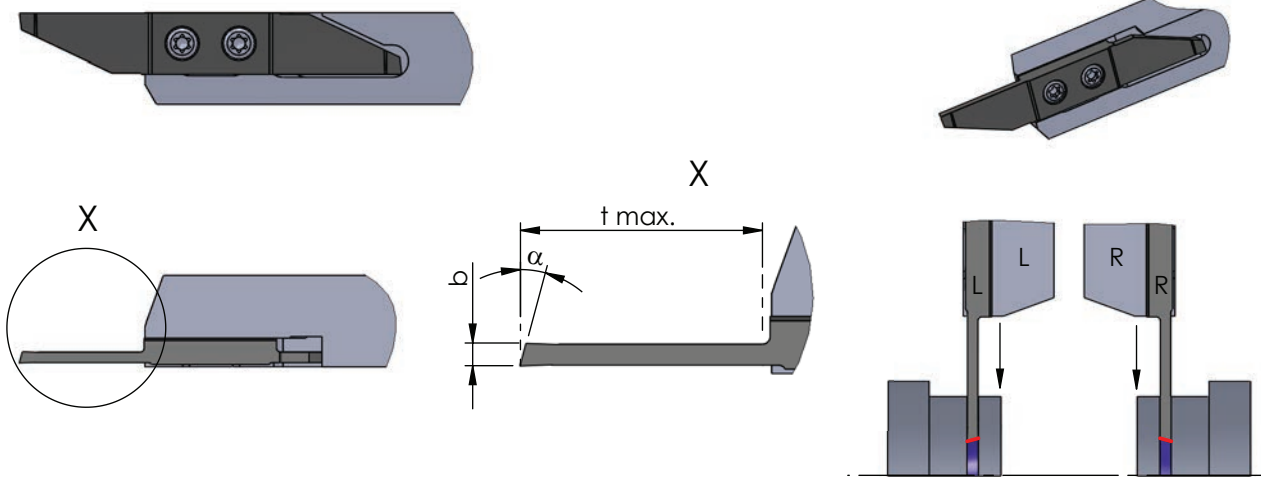

Rechts (R): wie gezeichnet  
Links (L): spiegelbildlich

Rechte Schneidpl. in rechtem Halter  
Linke Schneidpl. in linkem Halter

Abmessungen in mm

righthand version (R): as shown  
lefthand version (L): mirror image

use RH insert in RH tool holder and  
LH insert in LH tool holder

dimensions in mm

Bestellnummer part number	b	t max.	$\alpha$	Klemmhalter Typ toolholder type			
				K10F	CN45F	AL41F	P18C
R/L ZW11.08061500	0.8	6	15°	●			●
R/L ZW11.08101500	0.8	10	15°	●			●
R/L ZW11.10061500	1.0	6	15°	●			●
R/L ZW11.10131500	1.0	13	15°	●			●
R/L ZW11.12061500	1.2	6	15°	●			●
R/L ZW11.15081500	1.5	8	15°	●			●
R/L ZW11.15161500	1.5	16	15°	●			●
R/L ZW11.18081500	1.8	8	15°	●			●
R/L ZW11.20101500	2.0	10	15°	●			●
R/L ZW11.20161500	2.0	16	15°	●			●
R/L ZW11.25131500	2.5	13	15°	●			●
R/L ZW11.25161500	2.5	16	15°	●			●
R/L ZW11.30161500	3.0	16	15°	●			●

R/L HW10...  
R/L HW15...  
R/L HW20...

Weitere HM Sorten können Sie in der Sorten-  
übersicht im Kapitel "Technische Hinweise" und  
der Preisliste finden.

Bestellbeispiel:  
für rechte Ausführung und Sorte  
RZW11.08061500/P18C

More carbide grades you can find in the grades  
summary in the chapter "technical instructions"  
and in the price list.

order example:  
righthand version and grade  
RZW11.08061500/P18C

## SWISSLINE

Miniatöraußenbearbeitung,  
zweischneidig

miniature external machining,  
two-cutting edges

## Typ ZW12

Wendeschneidplatten,  
Abstechen mit Gegenspindel

indexable inserts,  
parting off with counter spindle

Stechtiefe  $t$  max. = 6 mm  
Stechbreite  $b$  = 0.8 / 1.2 mm

depth of groove  $t$  max. = 6 mm  
width of groove  $b$  = 0.8 / 1.2 mm

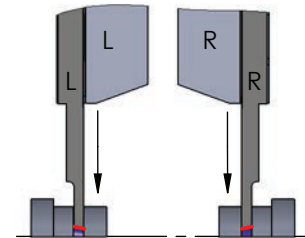
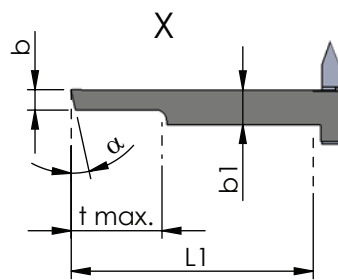
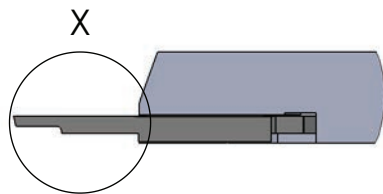
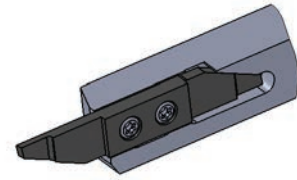

Rechts (R): wie gezeichnet  
Links (L): spiegelbildlich

Rechte Schneidpl. in rechtem Halter  
Linke Schneidpl. in linkem Halter

Abmessungen in mm

righthand version (R): as shown  
lefthand version (L): mirror image

use RH insert in RH tool holder and  
LH insert in LH tool holder

dimensions in mm



Bestellnummer part number	b	t max.	$\alpha$	L1	b1	Klemmhalter Typ toolholder type				
						K10F	CN45F	AL41F	P18C	
R/L ZW12.08061500	0.8	6	15°	16	2.0	●	●	●	●	R/L HW10... R/L HW15... R/L HW20...
R/L ZW12.12061500	1.2	6	15°	16	2.4	●	●	●	●	

Weitere HM Sorten können Sie in der Sorten-  
übersicht im Kapitel "Technische Hinweise" und  
der Preisliste finden.

Bestellbeispiel:  
für rechte Ausführung und Sorte  
RZW12.08061500/P18C

More carbide grades you can find in the grades  
summary in the chapter "technical instructions"  
and in the price list.

order example:  
righthand version and grade  
RZW12.08061500/P18C



## SWISSLINE

Miniatöraußenbearbeitung,  
zweischneidig

miniature external machining,  
two-cutting edges

## Typ ZW13

Wendeschneidplatten,  
Abstechen mit Gegenspindel,  
Schneide versetzt

indexable inserts,  
parting off with counter spindle,  
offset cutting edge

Stechtiefe  $t$  max. = 6 mm  
Stechbreite  $b$  = 0.8 / 1.2 mm

depth of groove  $t$  max. = 6 mm  
width of groove  $b$  = 0.8 / 1.2 mm

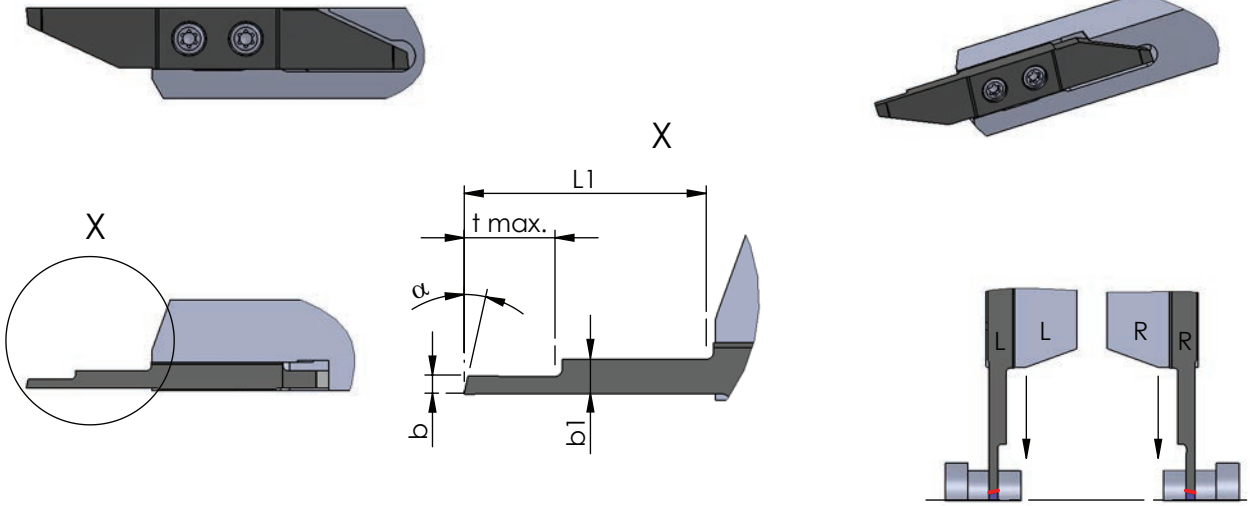

Rechts (R): wie gezeichnet  
Links (L): spiegelbildlich

Rechte Schneidpl. in rechtem Halter  
Linke Schneidpl. in linkem Halter

Abmessungen in mm

righthand version (R): as shown  
lefthand version (L): mirror image

use RH insert in RH tool holder and  
LH insert in LH tool holder

dimensions in mm

Bestellnummer part number	b	t max.	$\alpha$	L1	b1	K10F	CN45F	AL41F	P18C	Klemmhalter Typ	toolholder type
R/L ZW13.08061500	0.8	6	15°	16	2.0	●				R/L HW10...	
R/L ZW13.12061500	1.2	6	15°	16	2.4	●				R/L HW15...	R/L HW20...

Weitere HM Sorten können Sie in der Sorten-  
übersicht im Kapitel "Technische Hinweise" und  
der Preisliste finden.

Bestellbeispiel:  
für rechte Ausführung und Sorte  
RZW13.08061500/P18C

More carbide grades you can find in the grades  
summary in the chapter "technical instructions"  
and in the price list.

order example:  
righthand version and grade  
RZW13.08061500/P18C

**BROTECH**

## SWISSLINE

Miniatúraußenbearbeitung,  
zweischneidig

miniature external machining,  
two-cutting edges

## Typ ZW14

Wendeschneidplatten,  
zum Abstechen,  
mit Spanformer

indexable inserts,  
for parting off,  
with chip former

Stechtiefe  $t$  max. = 8 - 16 mm  
Stechbreite  $b$  = 1.5 - 3 mm

depth of groove  $t$  max. = 8 - 16 mm  
width of groove  $b$  = 1.5 - 3 mm

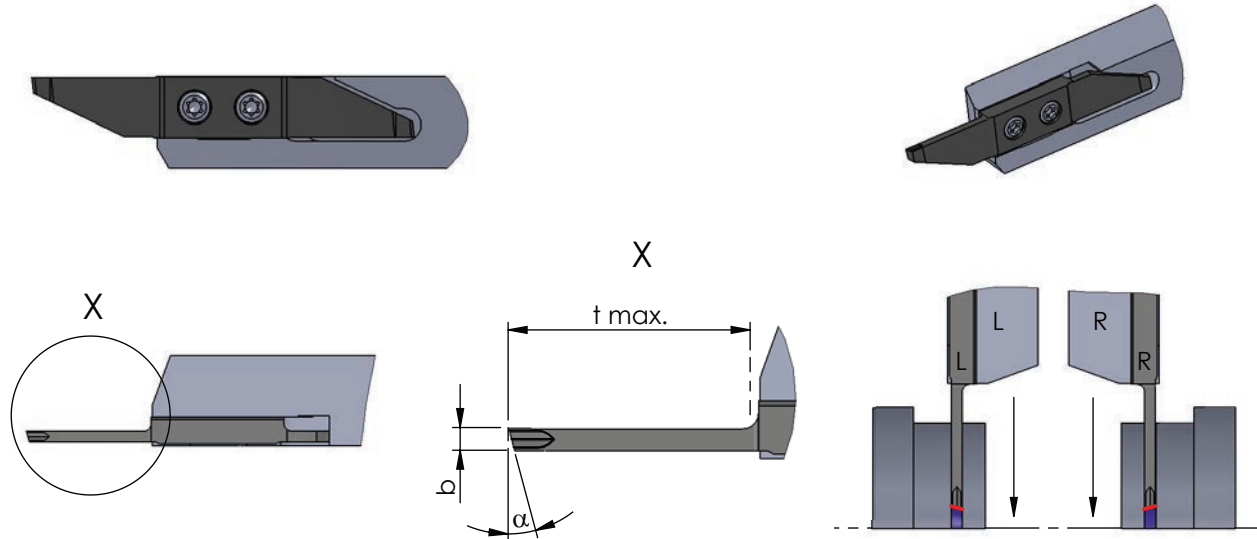

Rechts (R): wie gezeichnet  
Links (L): spiegelbildlich

Rechte Schneidpl. in rechtem Halter  
Linke Schneidpl. in linkem Halter

Abmessungen in mm

righthand version (R): as shown  
lefthand version (L): mirror image

use RH insert in RH tool holder and  
LH insert in LH tool holder

dimensions in mm



Bestellnummer part number	b	t max.	α	Klemmhalter Typ toolholder type			
				K10F	CN45F	AL41F	P18C
R/L ZW14.15081500	1.5	8	15°	●			●
R/L ZW14.15161500	1.5	16	15°	●			●
R/L ZW14.20101500	2.0	10	15°	●			●
R/L ZW14.20161500	2.0	16	15°	●			●
R/L ZW14.25131500	2.5	13	15°	●			●
R/L ZW14.25161500	2.5	16	15°	●			●
R/L ZW14.30161500	3.0	16	15°	●			●

Weitere HM Sorten können Sie in der Sorten-  
übersicht im Kapitel "Technische Hinweise" und  
der Preisliste finden.

Bestellbeispiel:  
für rechte Ausführung und Sorte  
RZW14.15081500/P18C

More carbide grades you can find in the grades  
summary in the chapter "technical instructions"  
and in the price list.

order example:  
righthand version and grade  
RZW14.15081500/P18C

## SWISSLINE

Miniatúraußenbearbeitung,  
zweischneidig

miniature external machining,  
two-cutting edges

## Typ ZW15

Wendeschneidplatten,  
zum Abstechen,  
Schneide versetzt, mit Spanformer

indexable inserts,  
for parting off,  
offset cutting edge, with chip former

Stechtiefe  $t$  max. = 8 - 16 mm  
Stechbreite  $b$  = 1.5 - 3 mm

depth of groove  $t$  max. = 8 - 16 mm  
width of groove  $b$  = 1.5 - 3 mm

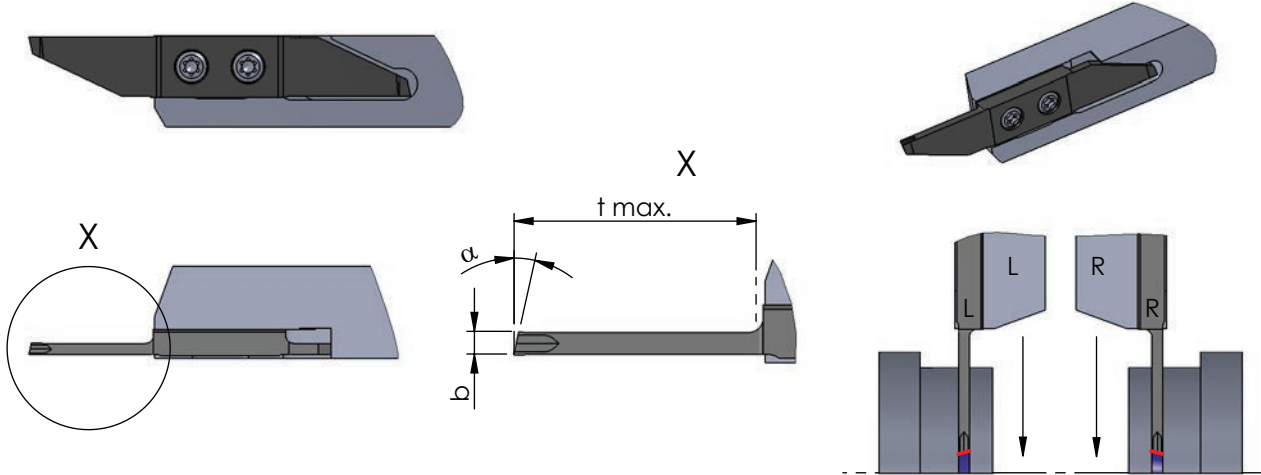

Rechts (R): wie gezeichnet  
Links (L): spiegelbildlich

Rechte Schneidpl. in rechtem Halter  
Linke Schneidpl. in linkem Halter

Abmessungen in mm

righthand version (R): as shown  
lefthand version (L): mirror image

use RH insert in RH tool holder and  
LH insert in LH tool holder

dimensions in mm

Bestellnummer part number	b	t max.	$\alpha$	Klemmhalter Typ toolholder type			
				K10F	CN45F	AL41F	P18C
R/L ZW15.15081500	1.5	8	15°	●			●
R/L ZW15.15161500	1.5	16	15°	●			●
R/L ZW15.20101500	2.0	10	15°	●			●
R/L ZW15.20161500	2.0	16	15°	●			●
R/L ZW15.25131500	2.5	13	15°	●			●
R/L ZW15.25161500	2.5	16	15°	●			●
R/L ZW15.30161500	3.0	16	15°	●			●

Weitere HM Sorten können Sie in der Sorten-  
übersicht im Kapitel "Technische Hinweise" und  
der Preisliste finden.

Bestellbeispiel:  
für rechte Ausführung und Sorte  
RZW15.15081500/P18C

More carbide grades you can find in the grades  
summary in the chapter "technical instructions"  
and in the price list.

order example:  
righthand version and grade  
RZW15.15081500/P18C

**BROTECH**

# SWISSLINE

Miniatöraußenbearbeitung,  
zweischneidig

miniature external machining,  
two-cutting edges

# Typ ZW16

Wendeschneidplatten,  
zum Abstechen,  
mit Spantreppe

indexable inserts,  
for parting off,  
with chip breaker

Stechtiefe  $t$  max. = 8 - 16 mm  
Stechbreite  $b$  = 1.5 - 3 mm

depth of groove  $t$  max. = 8 - 16 mm  
width of groove  $b$  = 1.5 - 3 mm

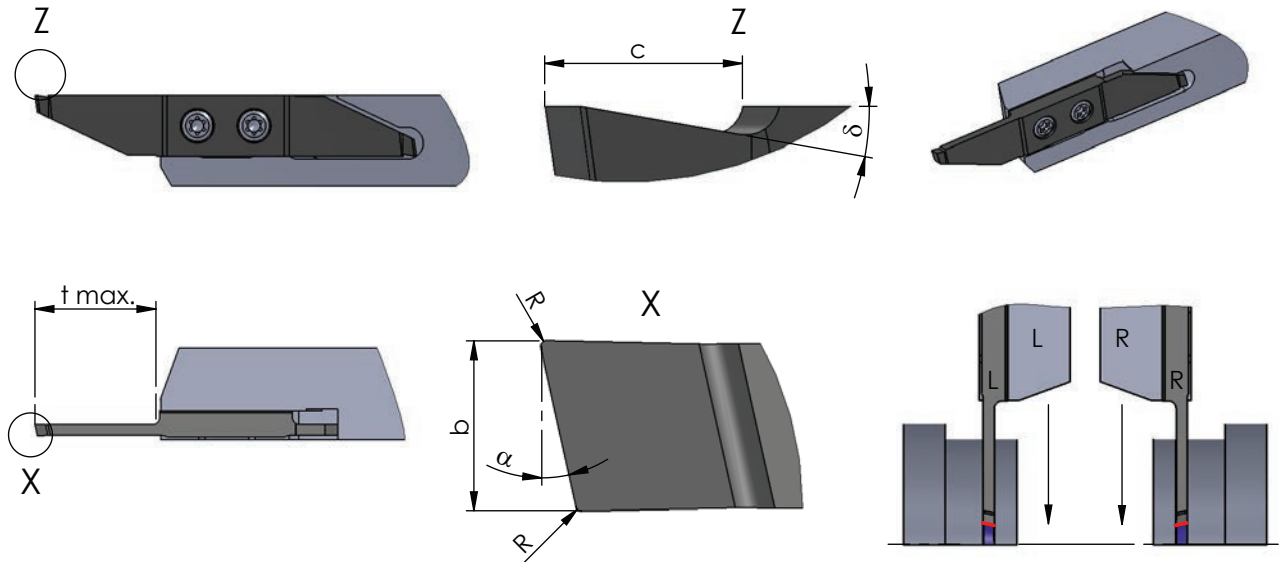

Rechts (R): wie gezeichnet  
Links (L): spiegelbildlich

Rechte Schneidpl. in rechtem Halter  
Linke Schneidpl. in linkem Halter

Abmessungen in mm

righthand version (R): as shown  
lefthand version (L): mirror image

use RH insert in RH tool holder and  
LH insert in LH tool holder

dimensions in mm



Bestellnummer part number	b	t max.	$\delta$	R	$\alpha$	c	Klemmhalter Typ toolholder type			
							K10F	CN45F	AL41F	P18C
R/L ZW16.15080605	1.5	8	6°	0.05	15°	2	●			
R/L ZW16.15081205	1.5	8	12°	0.05	15°	2	●			
R/L ZW16.20100605	2.0	10	6°	0.05	15°	2	●			
R/L ZW16.20101205	2.0	10	12°	0.05	15°	2	●			
R/L ZW16.20102000	2.0	10	20°	-	15°	2	●			
R/L ZW16.20160605	2.0	16	6°	0.05	15°	2	●			
R/L ZW16.20161205	2.0	16	12°	0.05	15°	2	●			R/L HW10... R/L HW15... R/L HW20...
R/L ZW16.25130605	2.5	13	6°	0.05	15°	2	●			
R/L ZW16.25131205	2.5	13	12°	0.05	15°	2	●			
R/L ZW16.25160605	2.5	16	6°	0.05	15°	2	●			
R/L ZW16.25161205	2.5	16	12°	0.05	15°	2	●			
R/L ZW16.30160605	3.0	16	6°	0.05	15°	2	●			
R/L ZW16.30161205	3.0	16	12°	0.05	15°	2	●			

Weitere HM Sorten können Sie in der Sortenübersicht im Kapitel "Technische Hinweise" und der Preisliste finden.

Bestellbeispiel:  
für rechte Ausführung und Sorte  
RZW16.15080605/P18C

More carbide grades you can find in the grades summary in the chapter "technical instructions" and in the price list.

order-example:  
righthand version and grade  
RZW16.15080605/P18C



## SWISSLINE

Miniatúraußenbearbeitung,  
zweischneidig

miniature external machining,  
two-cutting edges

## Typ ZW17

Wendeschneidplatten,  
zum Abstechen,  
Schneide versetzt, mit Spantreppe

indexable inserts,  
for parting off,  
offset cutting edge, with chip breaker

Stechtiefe  $t$  max. = 8 - 16 mm  
Stechbreite  $b$  = 1.5 - 3 mm

depth of groove  $t$  max. = 8 - 16 mm  
width of groove  $b$  = 1.5 - 3 mm

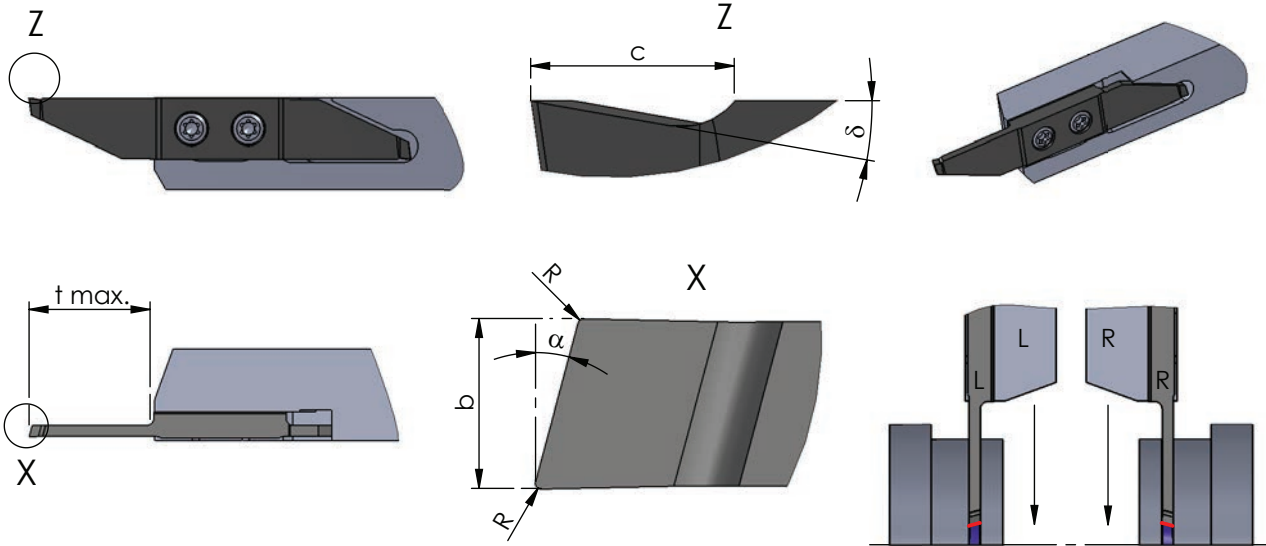

Rechts (R): wie gezeichnet  
Links (L): spiegelbildlich

Rechte Schneidpl. in rechtem Halter  
Linke Schneidpl. in linkem Halter

Abmessungen in mm

righthand version (R): as shown  
lefthand version (L): mirror image

use RH insert in RH tool holder and  
LH insert in LH tool holder

dimensions in mm

Bestellnummer part number	b	t max.	delta	R	alpha	c	Klemmhalter Typ toolholder type			
							K10F	CN45F	AL41F	P18C
R/L ZW17.15080605	1.5	8	6°	0.05	15°	2	●			
R/L ZW17.15081205	1.5	8	12°	0.05	15°	2	●			
R/L ZW17.20100605	2.0	10	6°	0.05	15°	2	●			
R/L ZW17.20101205	2.0	10	12°	0.05	15°	2	●			
R/L ZW17.20160605	2.0	16	6°	0.05	15°	2	●			
R/L ZW17.20161205	2.0	16	12°	0.05	15°	2	●			R/L HW10,...
R/L ZW17.25130605	2.5	13	6°	0.05	15°	2	●			R/L HW15,...
R/L ZW17.25131205	2.5	13	12°	0.05	15°	2	●			R/L HW20,...
R/L ZW17.25160605	2.5	16	6°	0.05	15°	2	●			
R/L ZW17.25161205	2.5	16	12°	0.05	15°	2	●			
R/L ZW17.30160605	3.0	16	6°	0.05	15°	2	●			
R/L ZW17.30161205	3.0	16	12°	0.05	15°	2	●			

Weitere HM Sorten können Sie in der Sorten-  
übersicht im Kapitel "Technische Hinweise" und  
der Preisliste finden.

Bestellbeispiel:  
für rechte Ausführung und Sorte  
RZW17.15080605/P18C

More carbide grades you can find in the grades  
summary in the chapter "technical instructions"  
and in the price list.

order example:  
righthand version and grade  
RZW17.15080605/P18C

**BROTECH**

## SWISSLINE

Miniatúraußenbearbeitung,  
zweischneidig

miniature external machining,  
two-cutting edges

## Typ ZW18

Wendeschneidplatten,  
zum Abstechen unter 0°,  
mit Spanformer

indexable inserts,  
for parting off with 0°,  
with chip former

Stechtiefe  $t$  max. = 10 - 16 mm  
Stechbreite  $b$  = 1.5 - 3 mm

depth of groove  $t$  max. = 10 - 16 mm  
width of groove  $b$  = 1.5 - 3 mm

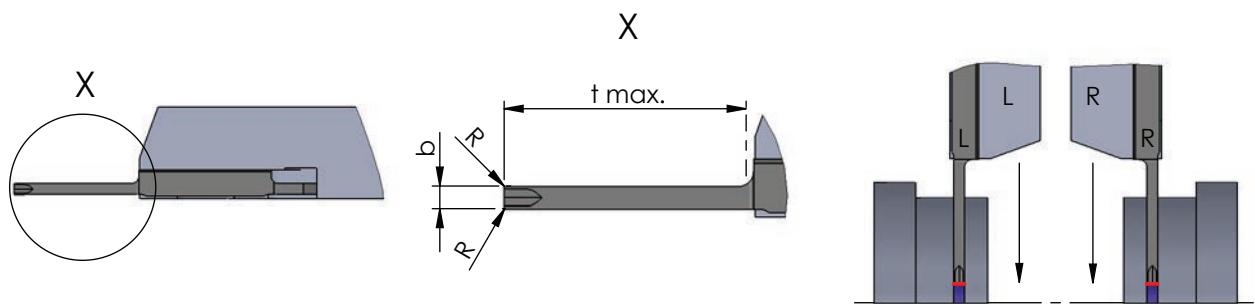
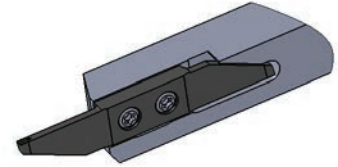

Rechts (R): wie gezeichnet  
Links (L): spiegelbildlich

Rechte Schneidpl. in rechtem Halter  
Linke Schneidpl. in linkem Halter

Abmessungen in mm

righthand version (R): as shown  
lefthand version (L): mirror image

use RH insert in RH tool holder and  
LH insert in LH tool holder

dimensions in mm



Bestellnummer part number	b	t max.	R	Klemmhalter Typ toolholder type			
				K10F	CN45F	AL41F	P18C
R/L ZW18.15100008	1.5	10	0.08	●			●
R/L ZW18.15160008	1.5	16	0.08	●			●
R/L ZW18.20100008	2.0	10	0.08	●			●
R/L ZW18.20160008	2.0	16	0.08	●			●
R/L ZW18.25130008	2.5	13	0.08	●			●
R/L ZW18.25160008	2.5	16	0.08	●			●
R/L ZW18.30160008	3.0	16	0.08	●			●

Weitere HM Sorten können Sie in der Sorten-  
übersicht im Kapitel "Technische Hinweise" und  
der Preisliste finden.

Bestellbeispiel:  
für rechte Ausführung und Sorte  
RZW18.15100008/P18C

More carbide grades you can find in the grades  
summary in the chapter "technical instructions"  
and in the price list.

order example:  
righthand version and grade  
RZW18.15100008/P18C

## SWISSLINE

Miniatúraußenbearbeitung,  
zweischneidig

miniature external machining,  
two-cutting edges

## Typ ZW19

Wendeschneidplatten,  
zum Abstechen unter 0°,  
mit Spantrepe

indexable inserts,  
for parting off with 0°,  
with chip breaker

Stechtiefe  $t$  max. = 10 - 16 mm  
Stechbreite  $b$  = 1.5 - 3 mm

depth of groove  $t$  max. = 10 - 16 mm  
width of groove  $b$  = 1.5 - 3 mm

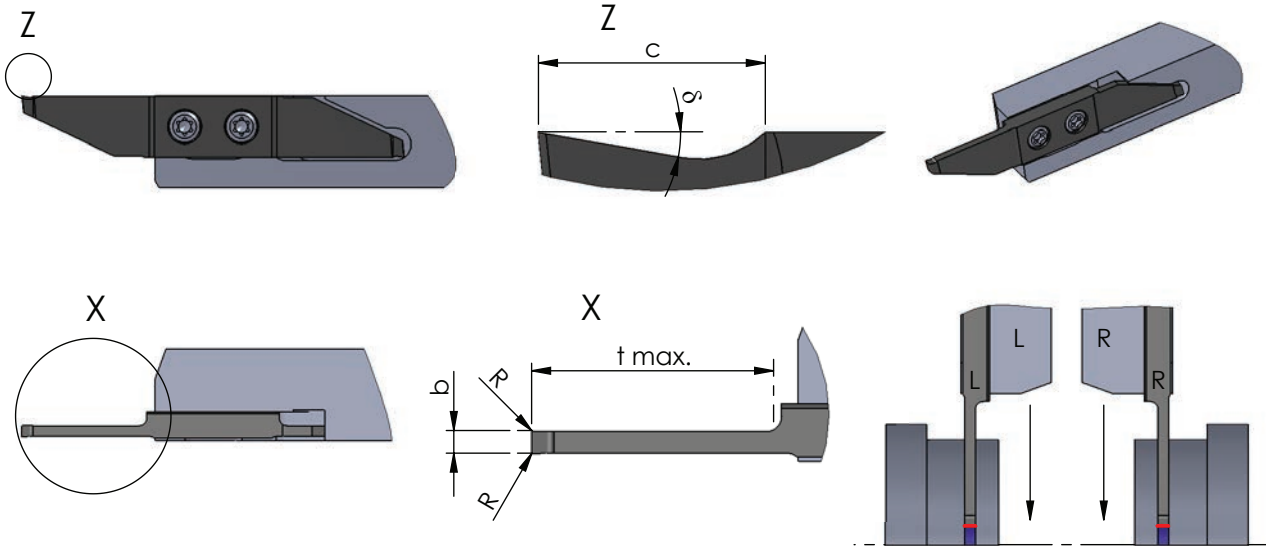

Rechts (R): wie gezeichnet  
Links (L): spiegelbildlich

Rechte Schneidpl. in rechtem Halter  
Linke Schneidpl. in linkem Halter

Abmessungen in mm

righthand version (R): as shown  
lefthand version (L): mirror image

use RH insert in RH tool holder and  
LH insert in LH tool holder

dimensions in mm

Bestellnummer part number	b	t max.	$\varphi$	R	c	Klemmhalter Typ toolholder type			
						K10F	CN45F	AL41F	P18C
R/L ZW19.15100605	1.5	10	6°	0.05	2	●			
R/L ZW19.15101205	1.5	10	12°	0.05	2	●			
R/L ZW19.20100605	2.0	10	6°	0.05	2	●			
R/L ZW19.20101205	2.0	10	12°	0.05	2	●			
R/L ZW19.20160605	2.0	16	6°	0.05	2	●			
R/L ZW19.20161205	2.0	16	12°	0.05	2	●			
R/L ZW19.25130605	2.5	13	6°	0.05	2	●			
R/L ZW19.25131205	2.5	13	12°	0.05	2	●			
R/L ZW19.25160605	2.5	16	6°	0.05	2	●			
R/L ZW19.25161205	2.5	16	12°	0.05	2	●			
R/L ZW19.30160605	3.0	16	6°	0.05	2	●			
R/L ZW19.30161205	3.0	16	12°	0.05	2	●			

R/L HW10, ...  
R/L HW15, ...  
R/L HW20, ...

Weitere HM Sorten können Sie in der Sorten-  
übersicht im Kapitel "Technische Hinweise" und  
der Preisliste finden.

Bestellbeispiel:  
für rechte Ausführung und Sorte  
RZW19.15100605/P18C

More carbide grades you can find in the grades  
summary in the chapter "technical instructions"  
and in the price list.

order example:  
righthand version and grade  
RZW19.15100605/P18C

**BROTECH**

## SWISSLINE

Miniatöraußenbearbeitung,  
zweischneidig

miniature external machining,  
two-cutting edges

## Typ ZW1A

Wendeschneidplatten,  
zum Abstechen,  
mit gesintertem Spanformer

indexable inserts,  
for parting off,  
with sintered chipformer

Stechtiefe  $t$  max. = 10 mm  
Stechbreite  $b$  = 2 mm

depth of groove  $t$  max. = 10 mm  
width of groove  $b$  = 2 mm

R/L ZW1A.201015GS: Schneide mit scharfer Schneidkante /  
insert with sharp cutting edge

R/L ZW1A.201015GX: Schneide mit gerundeter Schneidkante /  
insert with rounded cutting edge

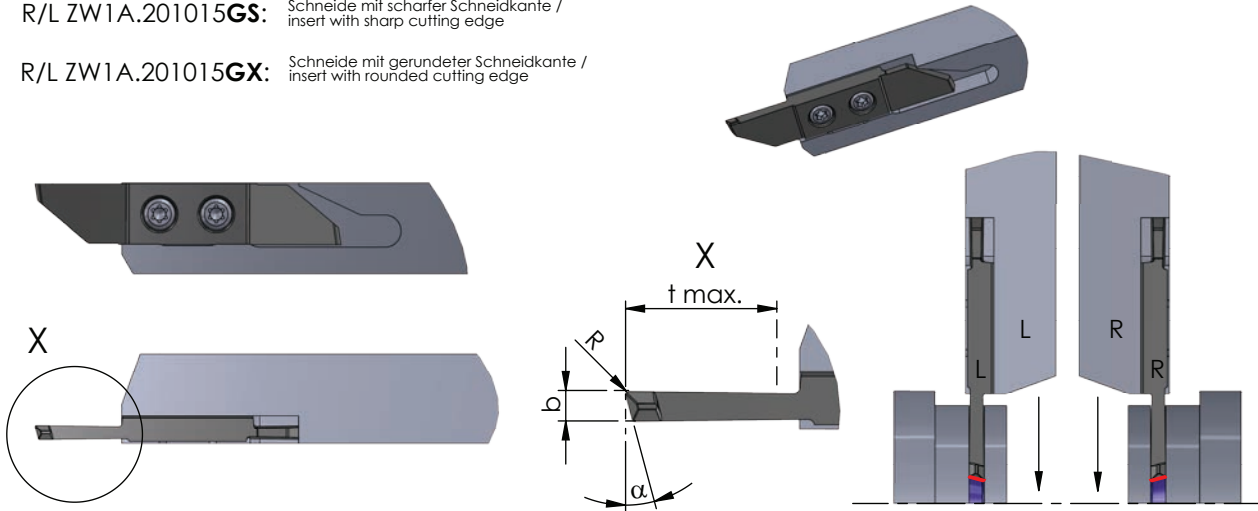

Rechts (R): wie gezeichnet  
Links (L): spiegelbildlich

Rechte Schneidpl. in rechtem Halter  
Linke Schneidpl. in linkem Halter

Abmessungen in mm

righthand version (R): as shown  
lefthand version (L): mirror image

use RH insert in RH tool holder and  
LH insert in LH tool holder

dimensions in mm



	Bestellnummer part number	b	t max.	$\alpha$	R	Klemmhalter Typ toolholder type				
						K10F	CN45F	AL41F	P18C	
neu	R/L ZW1A.201015GS	2.0	10	15°	0.2	●	●	●	●	R/L HW10... R/L HW15... R/L HW20...
neu	R/L ZW1A.201015GX	2.0	10	15°	0.2	●	●	●	●	

Weitere HM Sorten können Sie in der Sorten-  
übersicht im Kapitel "Technische Hinweise" und  
der Preisliste finden.

Bestellbeispiel:  
für rechte Ausführung und Sorte  
RZW1A.201015GS/P18C

More carbide grades you can find in the grades  
summary in the chapter "technical instructions"  
and in the price list.

order example:  
righthand version and grade  
RZW1A.201015GS/P18C

**BROTECH**



**SWISSLINE**

Miniatöraußenbearbeitung,  
zweischneidig

miniature external machining,  
two-cutting edges

**Typ ZW1B**

Wendeschneidplatten,  
zum Abstechen, Schneide versetzt,  
mit gesintertem Spanformer

indexable inserts,  
for parting off, offset cutting edge,  
with sintered chipformer

Stechtiefe  $t$  max. = 10 mm  
Stechbreite  $b$  = 2 mm

depth of groove  $t$  max. = 10 mm  
width of groove  $b$  = 2 mm

R/L ZW1B.201015GS: Schneide mit scharfer Schneidkante /  
insert with sharp cutting edge

R/L ZW1B.201015GX: Schneide mit gerundeter Schneidkante /  
insert with rounded cutting edge

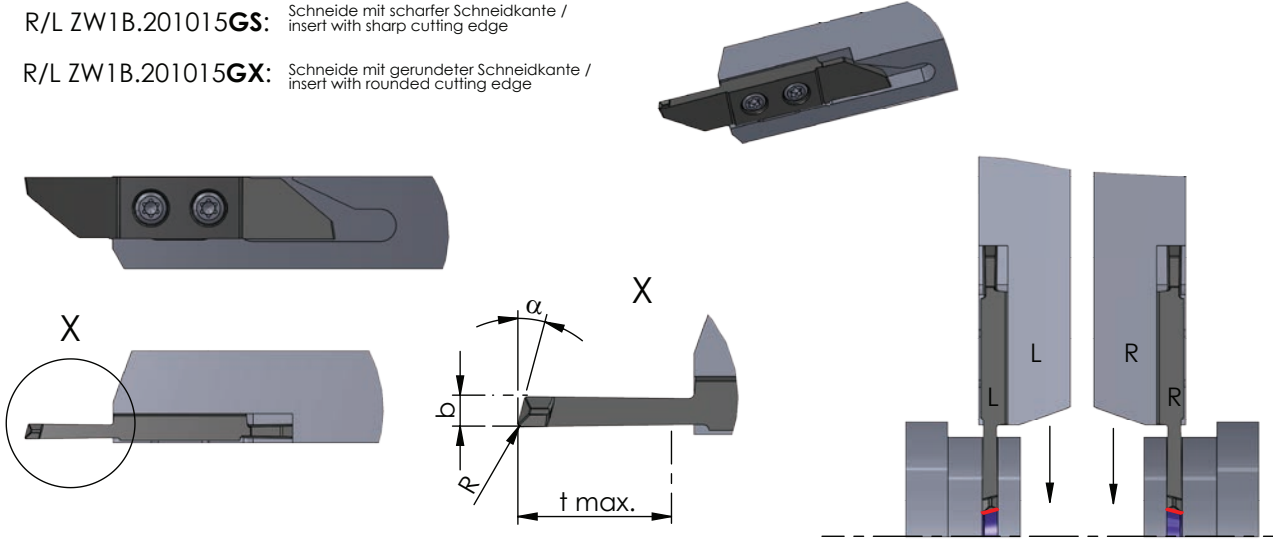

Rechts (R): wie gezeichnet  
Links (L): spiegelbildlich

Rechte Schneidpl. in rechtem Halter  
Linke Schneidpl. in linkem Halter

Abmessungen in mm

righthand version (R): as shown  
lefthand version (L): mirror image

use RH insert in RH tool holder and  
LH insert in LH tool holder

dimensions in mm

Bestellnummer part number	b	t max.	$\alpha$	R	K10F	CN45F	AL41F	P18C	Klemmhalter Typ	toolholder type
neu R/L ZW1B.201015GS	2.0	10	15°	0.2	●			●	R/L HW10...	
neu R/L ZW1B.201015GX	2.0	10	15°	0.2	●			●	R/L HW15...	R/L HW20...

Weitere HM Sorten können Sie in der Sorten-  
übersicht im Kapitel "Technische Hinweise" und  
der Preisliste finden.

Bestellbeispiel:  
für rechte Ausführung und Sorte  
RZW1B.201015GS/P18C

More carbide grades you can find in the grades  
summary in the chapter "technical instructions"  
and in the price list.

order example:  
righthand version and grade  
RZW1B.201015GS/P18C



# SWISSLINE

Miniaturaußenbearbeitung,  
zweischneidig

miniature external machining,  
two-cutting edges

# Typ ZW1C

Wendeschneidplatten,  
zum Abstechen unter 0°,  
mit gesintertem Spanformer

indexable inserts,  
for parting off with 0°,  
with sintered chip former

Stechtiefe t max. = 10 mm  
Stechbreite b = 2 mm

depth of groove t max. = 10 mm  
width of groove b = 2 mm



R/L ZW1C.201000GS: Schneide mit scharfer Schneidkante / insert with sharp cutting edge

R/L ZW1C.201000GX: Schneide mit gerundeter Schneidkante / insert with rounded cutting edge

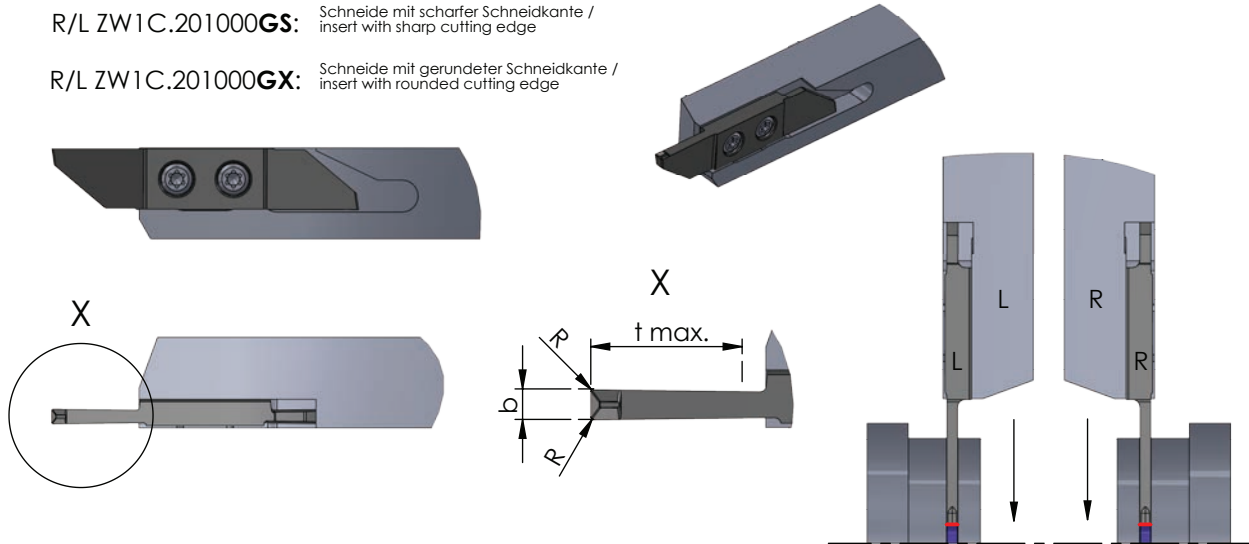

Rechts (R): wie gezeichnet  
Links (L): spiegelbildlich

Rechte Schneidpl. in rechtem Halter  
Linke Schneidpl. in linkem Halter

Abmessungen in mm

righthand version (R): as shown  
lefthand version (L): mirror image

use RH insert in RH tool holder and  
LH insert in LH tool holder

dimensions in mm

	Bestellnummer part number	b	t max.	R	Klemmhalter Typ toolholder type			
					K10F	CN45F	AL41F	P18C
neu	R/L ZW1C.201000GS	2.0	10	0.2	●		●	R/L HW10... R/L HW15... R/L HW20...
neu	R/L ZW1C.201000GX	2.0	10	0.2	●		●	

Weitere HM Sorten können Sie in der Sortenübersicht im Kapitel "Technische Hinweise" und der Preisliste finden.

Bestellbeispiel:  
für rechte Ausführung und Sorte  
RZW1C.201000GS/P18C

More carbide grades you can find in the grades summary in the chapter "technical instructions" and in the price list.

order example:  
righthand version and grade  
RZW1C.201000GS/P18C



## SWISSLINE

Miniaturaußenbearbeitung,  
zweischneidig

miniature external machining,  
two-cutting edges

## Typ ZW20

Wendeschneidplatten,  
Drehen und Abstechen,  
Wipergeometrie

indexable inserts,  
turning and parting off,  
wiper geometry

Stechtiefe  $t$  max. = 10 mm  
Stechbreite  $b$  = 2 mm

depth of groove  $t$  max. = 10 mm  
width of groove  $b$  = 2 mm

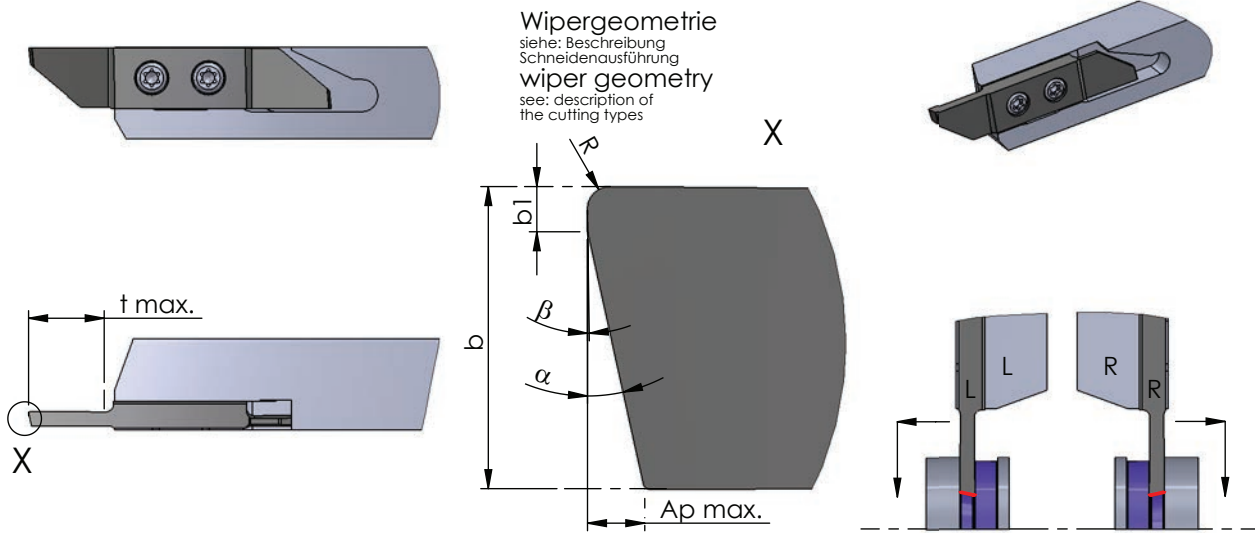

Rechts (R): wie gezeichnet  
Links (L): spiegelbildlich

Rechte Schneidpl. in rechtem Halter  
Linke Schneidpl. in linkem Halter

Abmessungen in mm

righthand version (R): as shown  
lefthand version (L): mirror image

use RH insert in RH tool holder and  
LH insert in LH tool holder

dimensions in mm

Bestellnummer part number	b	t max.	$\alpha$	R	$\beta$	b1	Ap max. *	Klemmhalter Typ toolholder type			
								K10F	CN45F	AL41F	P18C
R/L ZW20.20101515	2	10	15°	0.15	1.5°	0.3	0.45	●		●	R/L HW10... R/L HW15... R/L HW20...

\*Ap max. = max. Schnitttiefe(werkstoffabhängig)

Weitere HM Sorten können Sie in der Sorten-  
übersicht im Kapitel "Technische Hinweise" und  
der Preisliste finden.

Bestellbeispiel: für rechte Ausführung und Sorte  
RZW20.20101515/P18C

\*Ap max. = maximum depth of cut  
(depending on material)

More carbide grades you can find in the grades  
summary in the chapter "technical instructions"  
and in the price list.  
order-example: righthand version and grade  
RZW20.20101515/P18C

# SWISSLINE

Miniaturaußenbearbeitung,  
zweischneidig

miniature external machining,  
two-cutting edges

# Typ ZW21

Wendeschneidplatten,  
Drehen und Abstechen,  
Schneide versetzt, Wipergeometrie

indexable inserts,  
turning and parting off,  
offset cutting edge, wiper geometry

Stechtiefe  $t \text{ max.} = 10 \text{ mm}$   
Stechbreite  $b = 2 \text{ mm}$

depth of groove  $t \text{ max.} = 10 \text{ mm}$   
width of groove  $b = 2 \text{ mm}$

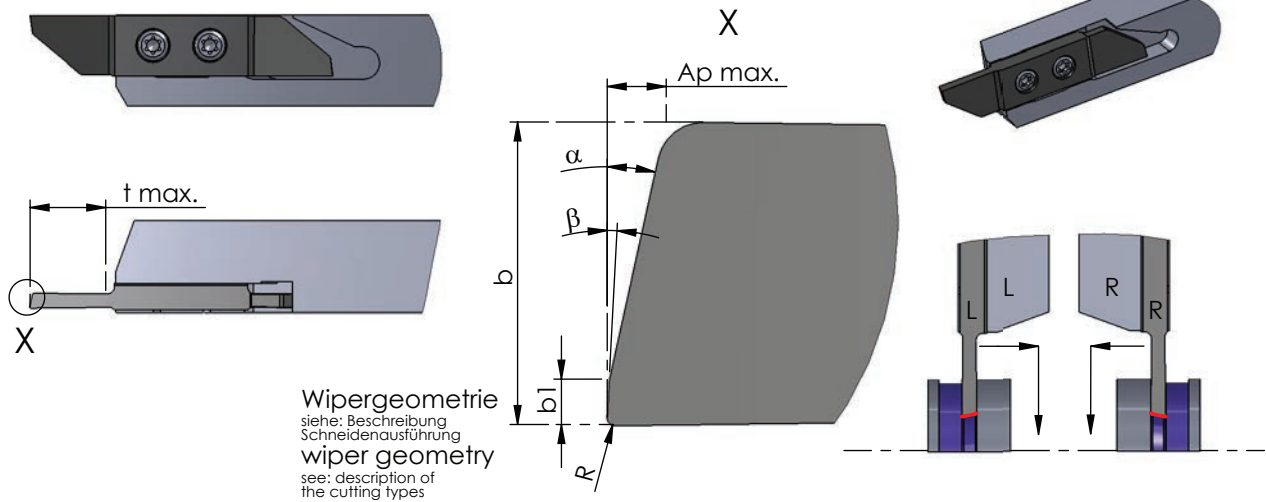

Rechts (R): wie gezeichnet  
Links (L): spiegelbildlich

Rechte Schneidpl. in rechtem Halter  
Linke Schneidpl. in linkem Halter

Abmessungen in mm

righthand version (R): as shown  
lefthand version (L): mirror image

use RH insert in RH tool holder and  
LH insert in LH tool holder

dimensions in mm



Bestellnummer part number	b	t max.	$\alpha$	R	$\beta$	b1	Ap max. *	Klemmhalter Typ toolholder type			
								K10F	CN45F	AL41F	P18C
R/L ZW21.20101515	2	10	15°	0.15	1.5°	0.3	0.45	●		●	R/L HW10... R/L HW15... R/L HW20...

\*Ap max. = max. Schnitttiefe(werkstoffabhängig)

Weitere HM Sorten können Sie in der Sorten-  
übersicht im Kapitel "Technische Hinweise" und  
der Preisliste finden.

Bestellbeispiel: für rechte Ausführung und Sorte  
RZW21.20101515/P18C

\*Ap max. = maximum depth of cut  
(depending on material)

More carbide grades you can find in the grades  
summary in the chapter "technical instructions"  
and in the price list.  
order-example: righthand version and grade  
RZW21.20101515/P18C

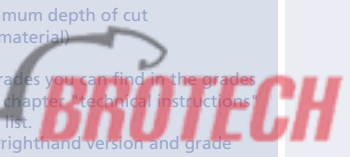

## SWISSLINE

Miniatöraußenbearbeitung,  
zweischneidig

miniature external machining,  
two-cutting edges

## Typ ZW22

Wendeschneidplatten,  
Drehen und Abstechen,  
mit Spanformer, Wipergeometrie

indexable inserts,  
turning and parting off,  
with chipformer, wiper geometry

Stechtiefe  $t$  max. = 10 mm  
Stechbreite  $b$  = 2 mm

depth of groove  $t$  max. = 10 mm  
width of groove  $b$  = 2 mm

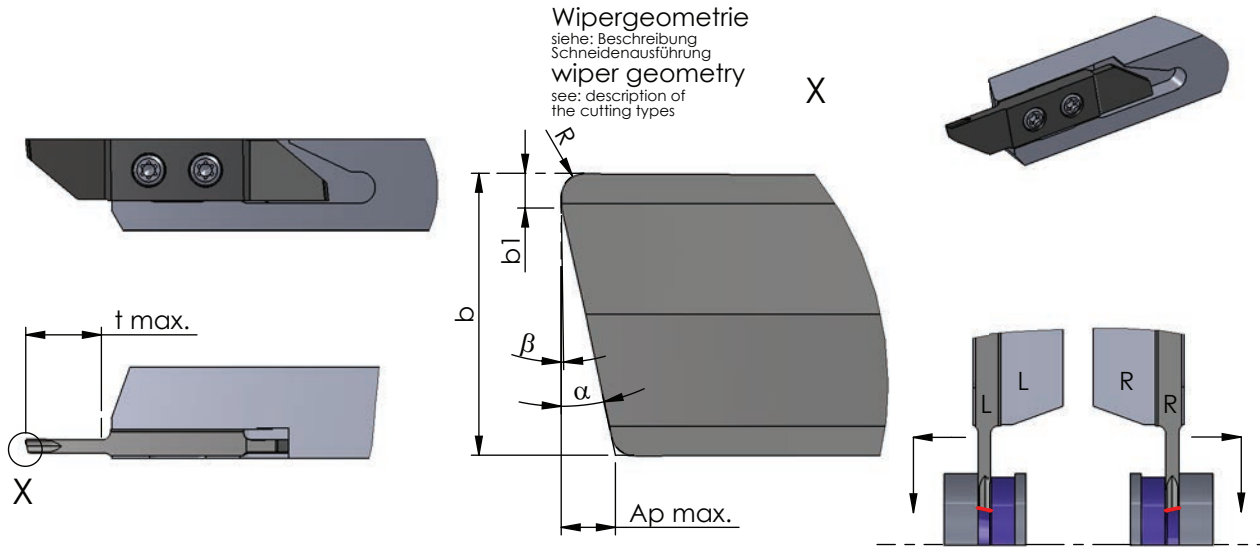

Rechts (R): wie gezeichnet  
Links (L): spiegelbildlich

Rechte Schneidpl. in rechtem Halter  
Linke Schneidpl. in linkem Halter

Abmessungen in mm

righthand version (R): as shown  
lefthand version (L): mirror image

use RH insert in RH tool holder and  
LH insert in LH tool holder

dimensions in mm

Bestellnummer part number	b	t max.	$\alpha$	R	$\beta$	b1	Ap max. *	Klemmhalter Typ toolholder type			
								K10F	CN45F	AL41F	P18C
R/L ZW22.20101515	2	10	15°	0.15	1.5°	0.3	0.45	●		●	R/L HW10... R/L HW15... R/L HW20...

\*Ap max. = max. Schnitttiefe(werkstoffabhängig)

Weitere HM Sorten können Sie in der Sorten-  
übersicht im Kapitel "Technische Hinweise" und  
der Preisliste finden.

Bestellbeispiel: für rechte Ausführung und Sorte  
RZW22.20101515/P18C

\*Ap max. = maximum depth of cut  
(depending on material)

More carbide grades you can find in the grades  
summary in the chapter "Technical instructions"  
and in the price list.  
order-example: righthand version and grade  
RZW22.20101515/P18C

# SWISSLINE

Miniaturaußenbearbeitung,  
zweischneidig

miniature external machining,  
two-cutting edges

# Typ ZW23

Wendeschneidplatten,  
Drehen u. Abstechen, Schneide versetzt,  
mit Spanformer, Wipergeometrie

indexable inserts,  
turning and parting off,  
offset cutting edge, with chipformer,  
wiper geometry

Stechtiefe  $t \text{ max.} = 10 \text{ mm}$   
Stechbreite  $b = 2 \text{ mm}$

depth of groove  $t \text{ max.} = 10 \text{ mm}$   
width of groove  $b = 2 \text{ mm}$

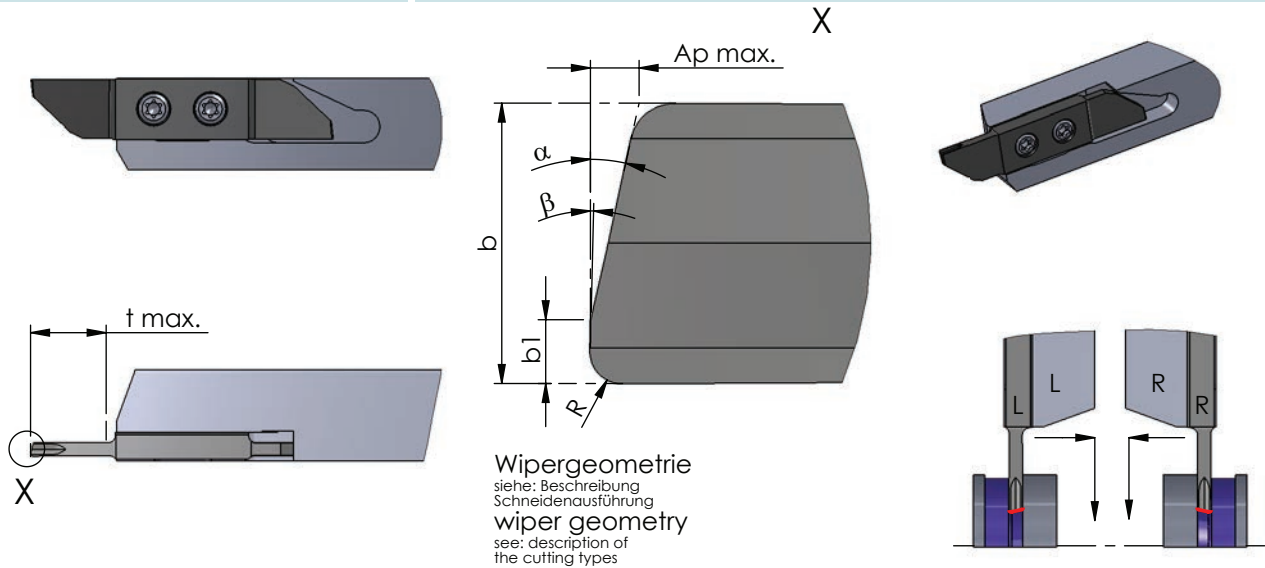

Rechts (R): wie gezeichnet  
Links (L): spiegelbildlich

Rechte Schneidpl. in rechtem Halter  
Linke Schneidpl. in linkem Halter

Abmessungen in mm

righthand version (R): as shown  
lefthand version (L): mirror image

use RH insert in RH tool holder and  
LH insert in LH tool holder

dimensions in mm

Bestellnummer part number	b	t max.	$\alpha$	R	$\beta$	b1	Ap max. *	Klemmhalter Typ toolholder type			
								K10F	CN45F	AL41F	P18C
R/L ZW23.20101515	2	10	15°	0.15	1.5°	0.3	0.45	●		●	R/L HW10... R/L HW15... R/L HW20...

\*Ap max. = max. Schnitttiefe(werkstoffabhängig)

Weitere HM Sorten können Sie in der Sorten-  
übersicht im Kapitel "Technische Hinweise" und  
der Preisliste finden.

Bestellbeispiel: für rechte Ausführung und Sorte  
RZW23.20101515/P18C

\*Ap max. = maximum depth of cut  
(depending on material)

More carbide grades you can find in the grades  
summary in the chapter "technical instructions"  
and in the price list.  
order-example: righthand version and grade  
RZW23.20101515/P18C

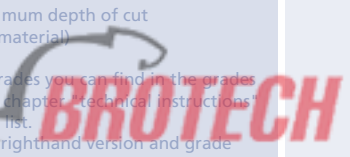

## SWISSLINE

Miniatöraußenbearbeitung,  
zweischneidig

miniature external machining,  
two-cutting edges

## Typ ZW30

Wendeschneidplatten,  
Vornedrehen

indexable inserts,  
turning in front

Stechtiefe  $t$  max. = 8 mm  
Stechbreite  $b$  = 3.4 mm

depth of groove  $t$  max. = 8 mm  
width of groove  $b$  = 3.4 mm

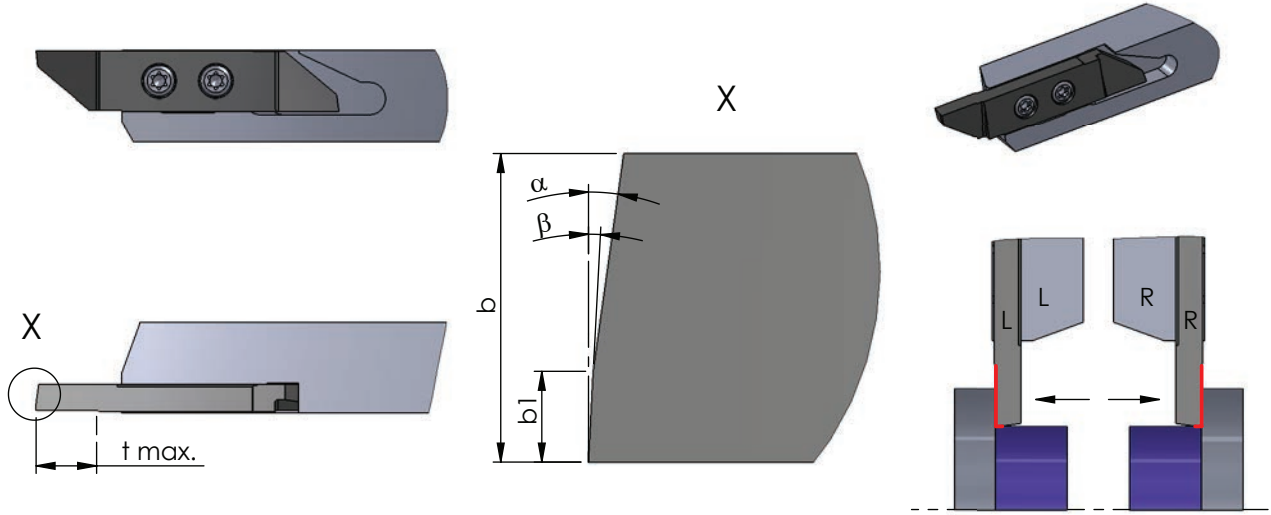

Rechts (R): wie gezeichnet  
Links (L): spiegelbildlich

Rechte Schneidpl. in rechtem Halter  
Linke Schneidpl. in linkem Halter

Abmessungen in mm

righthand version (R): as shown  
lefthand version (L): mirror image

use RH insert in RH tool holder and  
LH insert in LH tool holder

dimensions in mm

Bestellnummer part number	b	t max.	$\alpha$	b1	$\beta$	K10F	CN45F	AL41F	P18C	Klemmhalter Typ	toolholder type	
R/L ZW30.34080800	3.4	8	8°	1	3°	●			●	R/L HW10...	R/L HW15...	R/L HW20...

Weitere HM Sorten können Sie in der Sorten-  
übersicht im Kapitel "Technische Hinweise" und  
der Preisliste finden.

Bestellbeispiel:  
für rechte Ausführung und Sorte  
RZW30.34080800/P18C

More carbide grades you can find in the grades  
summary in the chapter "technical instructions"  
and in the price list.

order example:  
righthand version and grade  
RZW30.34080800/P18C

## SWISSLINE

Miniatúraußenbearbeitung,  
zweischneidig

miniature external machining,  
two-cutting edges

## Typ ZW31

Wendeschneidplatten,  
Vornedrehen,  
mit Spanformer, Wipergeometrie

indexable inserts,  
turning in front,  
with chip former, wiper geometry

Stechtiefe  $t$  max. = 8 mm  
Stechbreite  $b$  = 3.4 mm

depth of groove  $t$  max. = 8 mm  
width of groove  $b$  = 3.4 mm

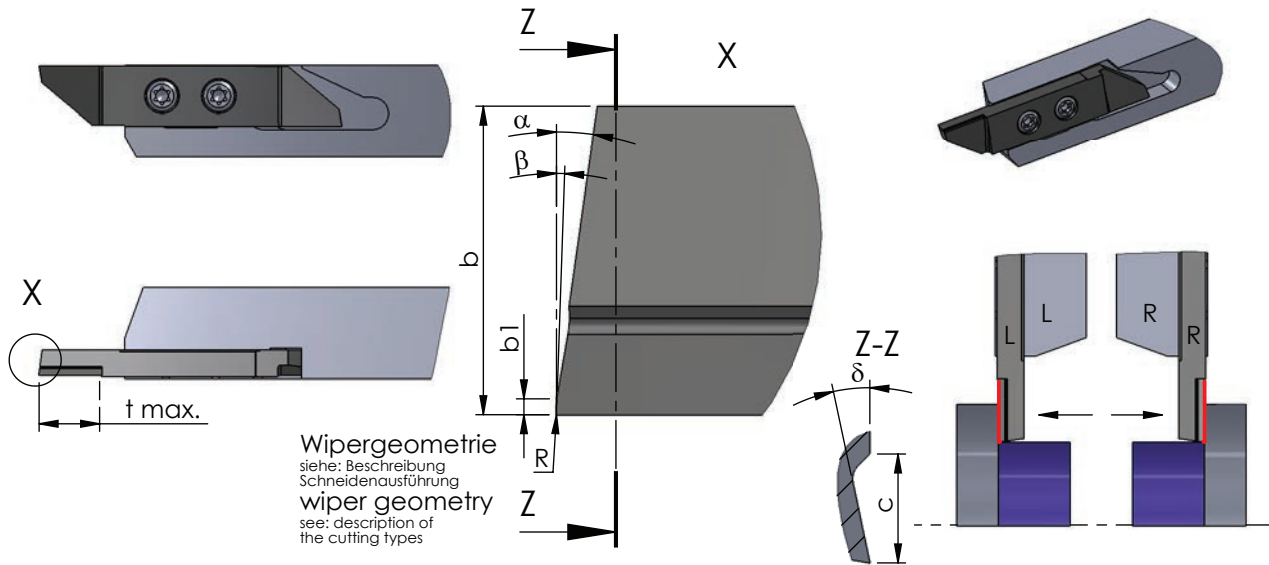

Rechts (R): wie gezeichnet  
Links (L): spiegelbildlich

Rechte Schneidpl. in rechtem Halter  
Linke Schneidpl. in linkem Halter

Abmessungen in mm

righthand version (R): as shown  
lefthand version (L): mirror image

use RH insert in RH tool holder and  
LH insert in LH tool holder

dimensions in mm



Bestellnummer part number	b	t max.	$\alpha$	R	b1	$\beta$	c	$\delta$	K10F	CN45F	AL41F	P18C	Klemmhalter Typ	toolholder type
R/L ZW31.34080800	3.4	8	8°	0	0.2	1°	1.2	12°	●			●		R/L HW10...
R/L ZW31.34084508	3.4	8	45°	0.08	1.2	1°	1.2	12°	●			●		R/L HW15...
R/L ZW31.34084515	3.4	8	45°	0.15	1.2	1°	1.2	12°	●			●		R/L HW20...

Weitere HM Sorten können Sie in der Sorten-  
übersicht im Kapitel "Technische Hinweise" und  
der Preisliste finden.

Bestellbeispiel:  
für rechte Ausführung und Sorte  
RZW31.34080800/P18C

More carbide grades you can find in the grades  
summary in the chapter "technical instructions"  
and in the price list.

order example:  
righthand version and grade  
RZW31.34080800/P18C

**BROTECH**



## SWISSLINE

Miniatöraußenbearbeitung,  
zweischneidig

miniature external machining,  
two-cutting edges

## Typ ZW40

Wendeschneidplatten,  
Kopierdrehen vorne,  
Schneide versetzt, mit Spanformer

indexable inserts,  
profiling in front,  
offset cutting edge, with chip former

Stechtiefe  $t$  max. = 11 mm  
Stechbreite  $b$  = 3.2 mm

depth of groove  $t$  max. = 11 mm  
width of groove  $b$  = 3.2 mm

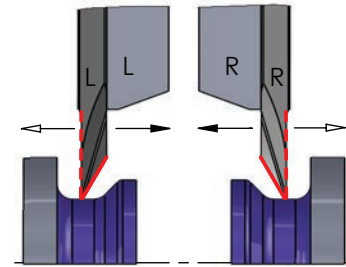
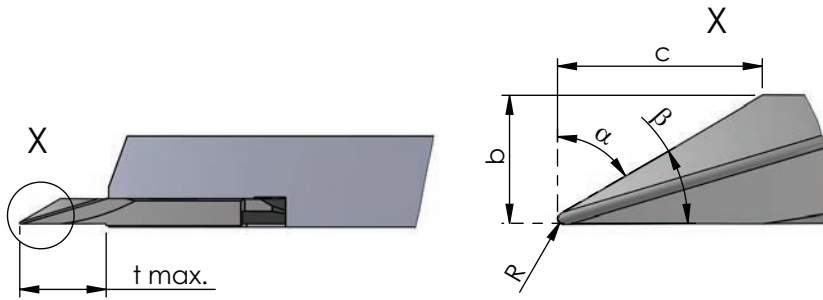
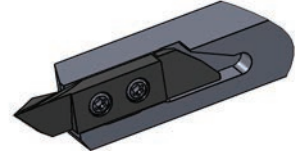

Rechts (R): wie gezeichnet  
Links (L): spiegelbildlich

Rechte Schneidpl. in rechtem Halter  
Linke Schneidpl. in linkem Halter

Abmessungen in mm

righthand version (R): as shown  
lefthand version (L): mirror image

use RH insert in RH tool holder and  
LH insert in LH tool holder

dimensions in mm

Bestellnummer part number	b	t max.	$\alpha$	R	$\beta$	c	Klemmhalter Typ toolholder type			
							K10F	CN45F	AL41F	P18C
R/L ZW40.32116108	3.2	11	61°	0.08	29°	5	●		●	
R/L ZW40.32116115	3.2	11	61°	0.15	29°	5	●		●	R/L HW10... R/L HW15... R/L HW20...
R/L ZW40.32116135	3.2	11	61°	0.35	29°	5	●		●	
R/L ZW40.32116175	3.2	11	61°	0.75	29°	5	●		●	

Weitere HM Sorten können Sie in der Sorten-  
übersicht im Kapitel "Technische Hinweise" und  
der Preisliste finden.

Bestellbeispiel:  
für rechte Ausführung und Sorte  
RZW40.32116108/P18C

More carbide grades you can find in the grades  
summary in the chapter "technical instructions"  
and in the price list.

order example:  
righthand version and grade  
RZW40.32116108/P18C

# SWISSLINE

Miniatúraußenbearbeitung,  
zweischneidig

miniature external machining,  
two-cutting edges

# Typ ZW41

Wendeschneidplatten,  
Kopierdrehen hinten,  
mit Spanformer

indexable inserts,  
profiling at the back,  
with chipformer

Stechtiefe  $t$  max. = 11 mm  
Stechbreite  $b$  = 3.2 mm

depth of groove  $t$  max. = 11 mm  
width of groove  $b$  = 3.2 mm

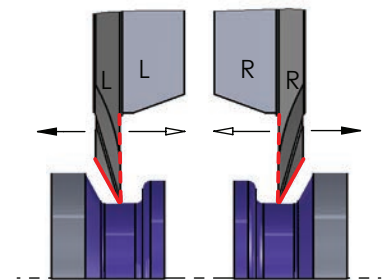
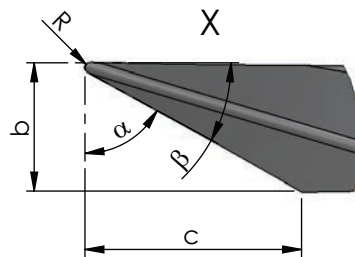
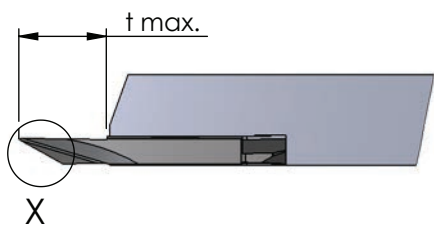
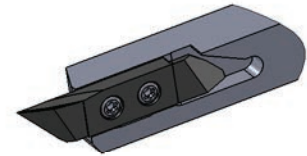

Rechts (R): wie gezeichnet  
Links (L): spiegelbildlich

Rechte Schneidpl. in rechtem Halter  
Linke Schneidpl. in linkem Halter

Abmessungen in mm

righthand version (R): as shown  
lefthand version (L): mirror image

use RH insert in RH tool holder and  
LH insert in LH tool holder

dimensions in mm



Bestellnummer part number	b	t max.	$\alpha$	R	$\beta$	c	Klemmhalter Typ toolholder type			
							K10F	CN45F	AL41F	P18C
R/L ZW41.32115515	3.2	11	55°	0.15	35°	4	●		●	
R/L ZW41.32115535	3.2	11	55°	0.35	35°	4	●		●	
R/L ZW41.32116108	3.2	11	61°	0.08	29°	5	●		●	R/L HW10,...
R/L ZW41.32116115	3.2	11	61°	0.15	29°	5	●		●	R/L HW15,...
R/L ZW41.32116135	3.2	11	61°	0.35	29°	5	●		●	R/L HW20,...
R/L ZW41.32116175	3.2	11	61°	0.75	29°	5	●		●	

Weitere HM Sorten können Sie in der Sorten-  
übersicht im Kapitel "Technische Hinweise" und  
der Preisliste finden.

Bestellbeispiel:  
für rechte Ausführung und Sorte  
RZW41.32115515/P18C

More carbide grades you can find in the grades  
summary in the chapter "technical instructions"  
and in the price list.

order example:  
righthand version and grade  
RZW41.32115515/P18C



**SWISSLINE**

Miniaturaußenbearbeitung,  
zweischneidig

miniature external machining,  
two-cutting edges

**Typ ZW50**

Wendeschneidplatten,  
Hintendreher, Wipergeometrie

indexable inserts,  
turning at the back, wiper geometry

Stechtiefe t max. = 6 - 8 mm  
Stechbreite b = 0.8 - 1.8 mm

depth of groove t max. = 6 - 8 mm  
width of groove b = 0.8 - 1.8 mm

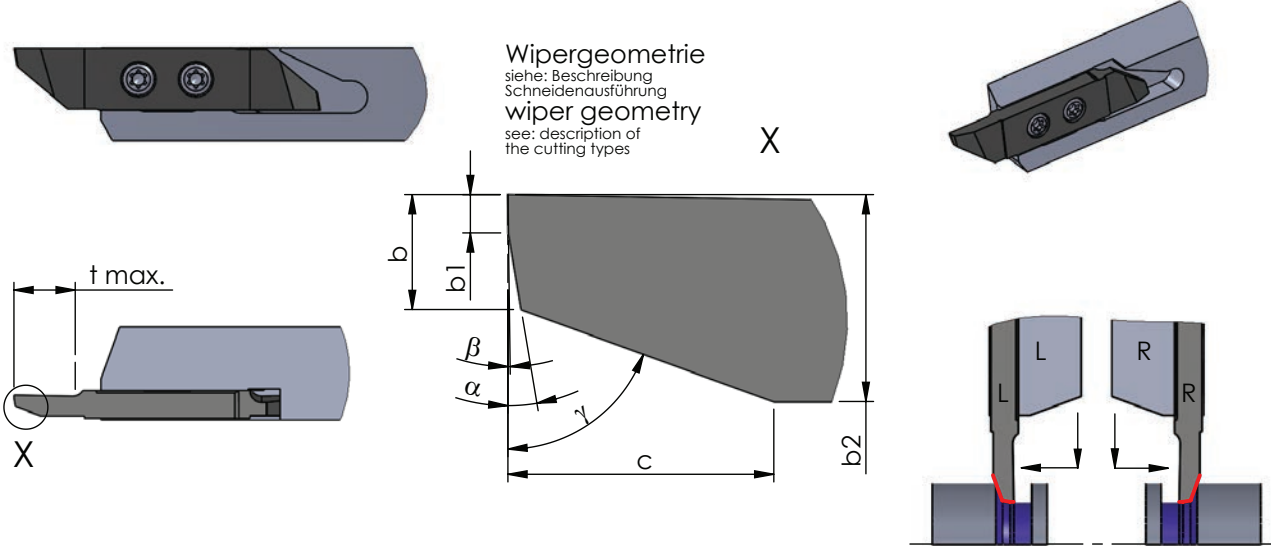

Rechts (R): wie gezeichnet  
Links (L): spiegelbildlich

Rechte Schneidpl. in rechtem Halter  
Linke Schneidpl. in linkem Halter

Abmessungen in mm

righthand version (R): as shown  
lefthand version (L): mirror image

use RH insert in RH tool holder and  
LH insert in LH tool holder

dimensions in mm

Bestellnummer part number	b	t max.	α	b1	b2	β	γ	c	K10F	CN45F	AL41F	P18C	Klemmhalter Typ	toolholder type
R/L ZW50.08060800	0.8	6	8°	0.5	2	1°	70°	3	●			●	R/L HW10.... R/L HW15.... R/L HW20....	
R/L ZW50.10060800	1.0	6	8°	0.5	2.2	1°	70°	3	●			●		
R/L ZW50.12080800	1.2	8	8°	0.5	2.4	1°	70°	3	●			●		
R/L ZW50.15080800	1.5	8	8°	0.5	2.7	1°	70°	3	●			●		
R/L ZW50.18080800	1.8	8	8°	0.5	3.0	1°	70°	3	●			●		

Weitere HM Sorten können Sie in der Sorten-  
übersicht im Kapitel "Technische Hinweise" und  
der Preisliste finden.

Bestellbeispiel:  
für rechte Ausführung und Sorte  
RZW50.08060800/P18C

More carbide grades you can find in the grades  
summary in the chapter "technical instructions"  
and in the price list.

order example:  
righthand version and grade  
RZW50.08060800/P18C



# SWISSLINE

Miniatöraußenbearbeitung,  
zweischneidig

miniature external machining,  
two-cutting edges

# Typ ZW51

Wendeschneidplatten,  
Kopierdrehen hinten,  
mit Spanformer, Wipergeometrie

indexable inserts,  
profiling at the back,  
with chip former, wiper geometry

Stechtiefe t max. = 6 mm  
Stechbreite b = 0.5 mm

depth of groove t max. = 6 mm  
width of groove b = 0.5 mm

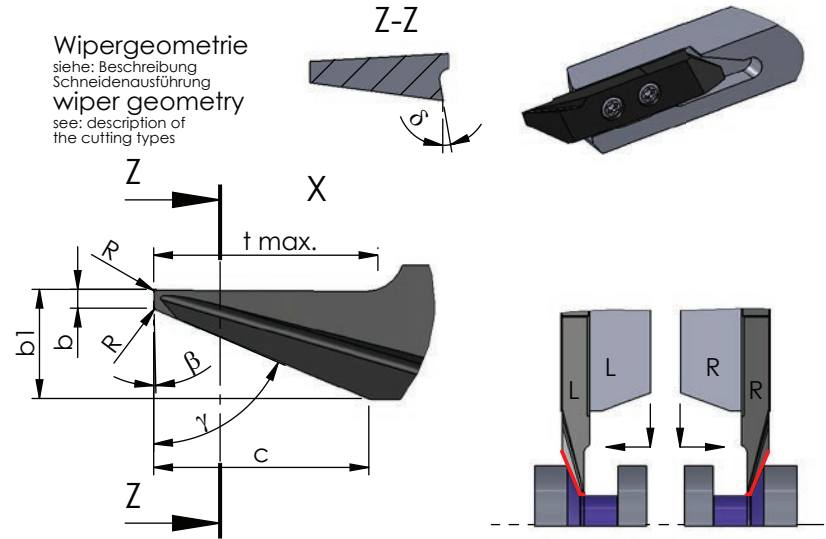
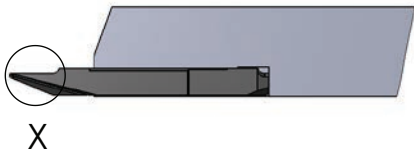

Wipergeometrie  
siehe: Beschreibung  
Schneidenausführung  
wiper geometry  
see: description of  
the cutting types

Rechts (R): wie gezeichnet  
Links (L): spiegelbildlich

Rechte Schneidpl. in rechtem Halter  
Linke Schneidpl. in linkem Halter

Abmessungen in mm

righthand version (R): as shown  
lefthand version (L): mirror image

use RH insert in RH tool holder and  
LH insert in LH tool holder

dimensions in mm



Bestellnummer part number	b	t max.	γ	R	b1	β	δ	c					Klemmhalter Typ toolholder type
									K10F	CN45F	AL41F	P18C	
R/L ZW51.05067000	0.5	6	70°	0	2.4	1.5°	15°	5	●			●	R/L HW10...
R/L ZW51.05067008	0.5	6	70°	0.08	2.4	1.5°	15°	5	●			●	R/L HW15...
R/L ZW51.05067015	0.5	6	70°	0.15	2.4	1.5°	15°	5	●			●	R/L HW20...

Weitere HM Sorten können Sie in der Sorten-  
übersicht im Kapitel "Technische Hinweise" und  
der Preisliste finden.

Bestellbeispiel:  
für rechte Ausführung und Sorte  
RZW51.05067000/P18C

More carbide grades you can find in the grades  
summary in the chapter "technical instructions"  
and in the price list.

order example:  
righthand version and grade  
RZW51.05067000/P18C



## SWISSLINE

Miniatöraußenbearbeitung,  
zweischneidig

miniature external machining,  
two-cutting edges

## Typ ZW52

Wendeschneidplatten,  
Hintendreher,  
mit Spantreppe

indexable inserts,  
turning at the back,  
with chip breaker

Stechtiefe  $t$  max. = 4.5 mm  
Stechbreite  $b$  = 0.8 mm

depth of groove  $t$  max. = 4.5 mm  
width of groove  $b$  = 0.8 mm

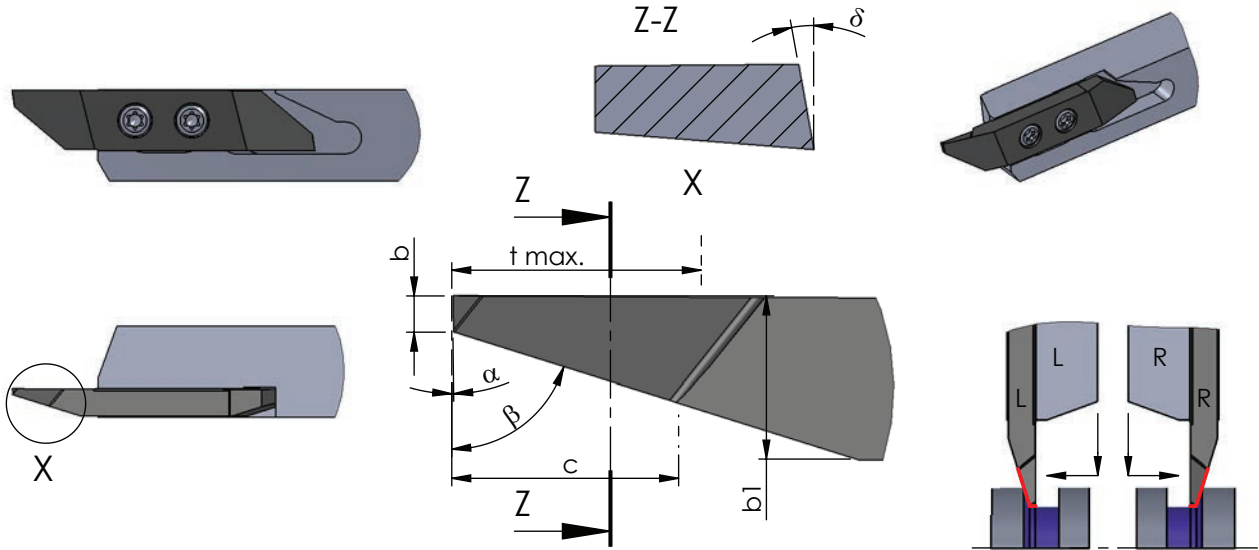

Rechts (R): wie gezeichnet  
Links (L): spiegelbildlich

Rechte Schneidpl. in rechtem Halter  
Linke Schneidpl. in linkem Halter

Abmessungen in mm

righthand version (R): as shown  
lefthand version (L): mirror image

use RH insert in RH tool holder and  
LH insert in LH tool holder

dimensions in mm

Bestellnummer part number	b	t max.	$\beta$	b1	$\alpha$	$\delta$	c	K10F	CN45F	AL41F	P18C	Klemmhalter Typ	toolholder type	
R/L ZW52.08047000	0.8	4.5	70°	3.2	2°	7°	4	●	●	●	●	R/L HW10...	R/L HW15...	R/L HW20...

Weitere HM Sorten können Sie in der Sorten-  
übersicht im Kapitel "Technische Hinweise" und  
der Preisliste finden.

Bestellbeispiel:  
für rechte Ausführung und Sorte  
RZW52.08047000/P18C

More carbide grades you can find in the grades  
summary in the chapter "technical instructions"  
and in the price list.

order example:  
righthand version and grade  
RZW52.08047000/P18C

**BROTECH**

## SWISSLINE

Miniatúraußenbearbeitung,  
zweischneidig

miniature external machining,  
two-cutting edges

## Typ ZW60

Wendeschneidplatten,  
Einstechen und Längsdrehen

indexable inserts,  
grooving and turning

Stechtiefe  $t$  max. = 2.5 - 6 mm  
Stechbreite  $b$  = 1 - 3 mm

depth of groove  $t$  max. = 2.5 - 6 mm  
width of groove  $b$  = 1 - 3 mm

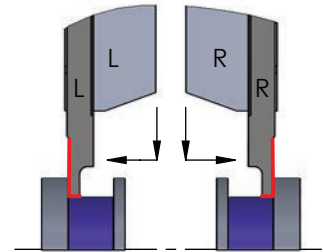
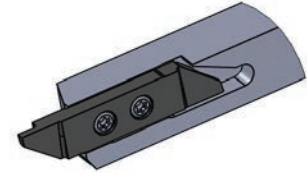
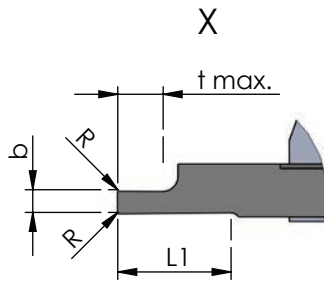
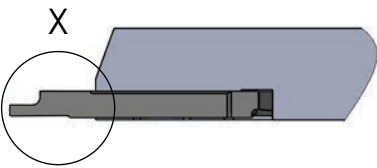

Rechts (R): wie gezeichnet  
Links (L): spiegelbildlich

Rechte Schneidpl. in rechtem Halter  
Linke Schneidpl. in linkem Halter

Abmessungen in mm

righthand version (R): as shown  
lefthand version (L): mirror image

use RH insert in RH tool holder and  
LH insert in LH tool holder

dimensions in mm



Bestellnummer part number	b	t max.	R	L1	Klemmhalter Typ toolholder type			
					K10F	CN45F	AL41F	P18C
R/L ZW60.10250005	1.0	2.5	0.05	8	●			●
R/L ZW60.15300005	1.5	3.0	0.05	8	●			●
R/L ZW60.20400005	2.0	4.0	0.05	8	●			●
R/L ZW60.25500005	2.5	5.0	0.05	8	●			●
R/L ZW60.30600005	3.0	6.0	0.05	8	●			●

Weitere HM Sorten können Sie in der Sorten-  
übersicht im Kapitel "Technische Hinweise" und  
der Preisliste finden.

Bestellbeispiel:  
für rechte Ausführung und Sorte  
RZW60.10250005/P18C

More carbide grades you can find in the grades  
summary in the chapter "technical instructions"  
and in the price list.

order example:  
righthand version and grade  
RZW60.10250005/P18C

**BROTECH**

## SWISSLINE

Miniatúraußenbearbeitung,  
zweischneidig

miniature external machining,  
two-cutting edges

## Typ ZW61

Wendeschneidplatten,  
Einstechen und Längsdrehen,  
mit Spantreppe

indexable inserts,  
grooving and turning,  
with chip breaker

Stechtiefe  $t \text{ max.} = 2.5 - 6 \text{ mm}$   
Stechbreite  $b = 0.8 - 3 \text{ mm}$

depth of groove  $t \text{ max.} = 2.5 - 6 \text{ mm}$   
width of groove  $b = 0.8 - 3 \text{ mm}$

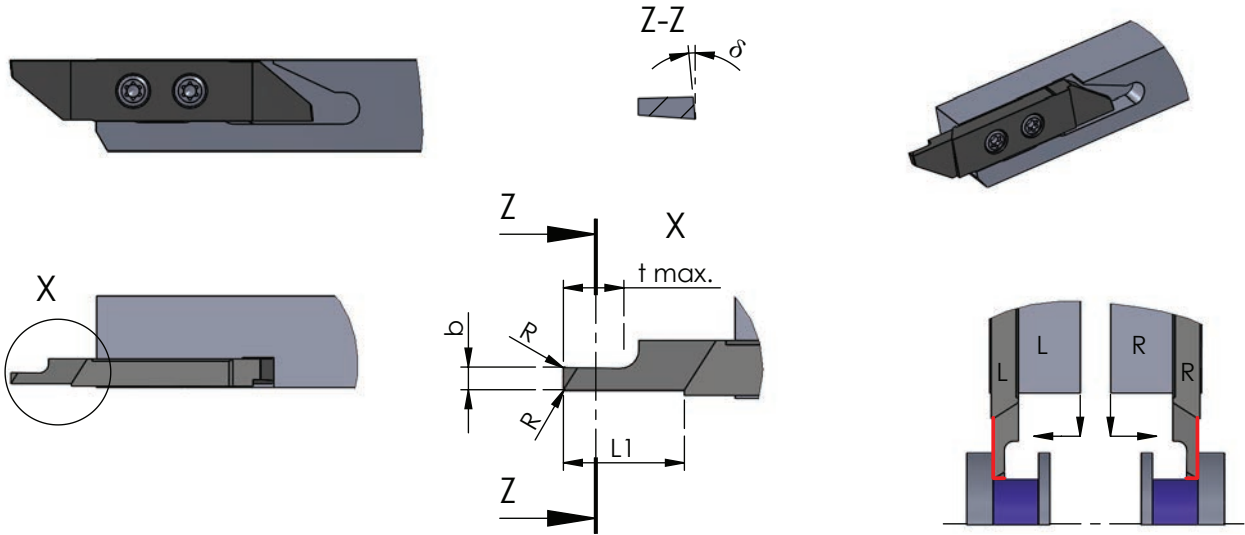

Rechts (R): wie gezeichnet  
Links (L): spiegelbildlich

Rechte Schneidpl. in rechtem Halter  
Linke Schneidpl. in linkem Halter

Abmessungen in mm

righthand version (R): as shown  
lefthand version (L): mirror image

use RH insert in RH tool holder and  
LH insert in LH tool holder

dimensions in mm

Bestellnummer part number	b	t max.	R	L1	$\alpha$	Klemmhalter Typ toolholder type			
						K10F	CN45F	AL41F	P18C
R/L ZW61.08250000	0.8	2.5	0	8	10°	●			
R/L ZW61.10350000	1.0	3.5	0	8	10°	●			
R/L ZW61.15400000	1.5	4.0	0	8	10°	●			
R/L ZW61.15400008	1.5	4.0	0.08	8	10°	●			
R/L ZW61.20500000	2.0	5.0	0	8	10°	●			
R/L ZW61.20500008	2.0	5.0	0.08	8	10°	●			
R/L ZW61.20500015	2.0	5.0	0.15	8	10°	●			R/L HW10... R/L HW15... R/L HW20...
R/L ZW61.25600000	2.5	6.0	0	8	10°	●			
R/L ZW61.25600008	2.5	6.0	0.08	8	10°	●			
R/L ZW61.25600015	2.5	6.0	0.15	8	10°	●			
R/L ZW61.30600000	3.0	6.0	0	8	10°	●			
R/L ZW61.30600008	3.0	6.0	0.08	8	10°	●			
R/L ZW61.30600015	3.0	6.0	0.15	8	10°	●			

Weitere HM Sorten können Sie in der Sorten-  
übersicht im Kapitel "Technische Hinweise" und  
der Preisliste finden.

Bestellbeispiel:  
für rechte Ausführung und Sorte  
RZW61.08250000/P18C

More carbide grades you can find in the grades  
summary in the chapter "technical instructions"  
and in the price list.

order example:  
righthand version and grade  
RZW61.08250000/P18C

# SWISSLINE

Miniatöraußenbearbeitung,  
zweischneidig

miniature external machining,  
two-cutting edges

# Typ ZW70

Wendeschneidplatten,  
Stechdrehen,  
Vollradius mit Spantreppe

indexable inserts,  
grooving,  
full radius with chip breaker

Stechtiefe t max. = 2 - 16 mm  
Stechbreite b = 0.5 - 3 mm

depth of groove t max. = 2 - 16 mm  
width of groove b = 0.5 - 3 mm

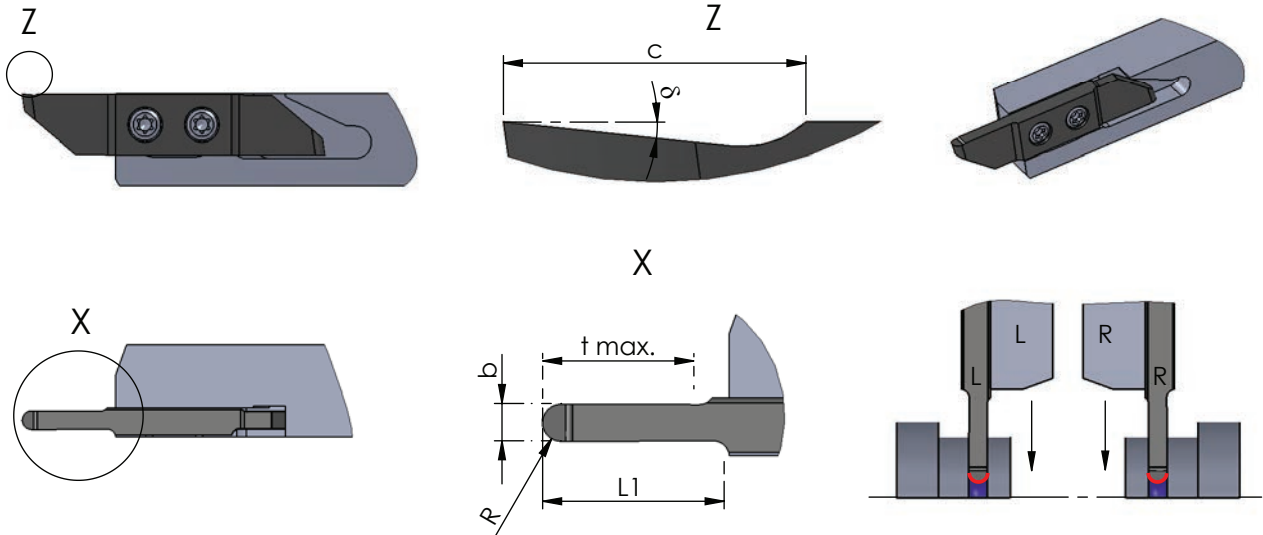

Rechts (R): wie gezeichnet  
Links (L): spiegelbildlich

Rechte Schneidpl. in rechtem Halter  
Linke Schneidpl. in linkem Halter

Abmessungen in mm

righthand version (R): as shown  
lefthand version (L): mirror image

use RH insert in RH tool holder and  
LH insert in LH tool holder

dimensions in mm



Bestellnummer part number	b	R	t max.	L1	α	c	Klemmhalter Typ toolholder type				
							K10F	CN45F	AL41F	P18C	
R/L ZW70.0502020	0.5	0.25	2.0	12	6°	2	●				
R/L ZW70.1005025	1.0	0.50	2.5	12	6°	2	●				
R/L ZW70.1206025	1.2	0.60	2.5	12	6°	2	●				
R/L ZW70.1507030	1.5	0.75	3.0	12	6°	2	●				
R/L ZW70.1608030	1.6	0.80	3.0	12	6°	2	●				
R/L ZW70.2010100	2.0	1.00	10	12	6°	2	●				
R/L ZW70.3015100	3.0	1.50	10	12	6°	2	●				
R/L ZW70.3015160	3.0	1.50	16	17	6°	2	●				

Weitere HM Sorten können Sie in der Sorten-  
übersicht im Kapitel "Technische Hinweise" und  
der Preisliste finden.

Bestellbeispiel:  
für rechte Ausführung und Sorte  
RZW70.0502020/P18C

More carbide grades you can find in the grades  
summary in the chapter "technical instructions"  
and in the price list.

order example:  
righthand version and grade  
RZW70.0502020/P18C





## SWISSLINE

Miniatöraußenbearbeitung,  
zweischneidig

miniature external machining,  
two-cutting edges

## Typ ZW90

Wendeschneidplatten,  
Gewindedrehen,  
Vollprofil, 60°

indexable inserts,  
threading,  
full profile, 60°

Gewinde M1 - M4.5  
Steigung P = 0.25 - 0.75

thread M1 - M4.5  
pitch P = 0.25 - 0.75

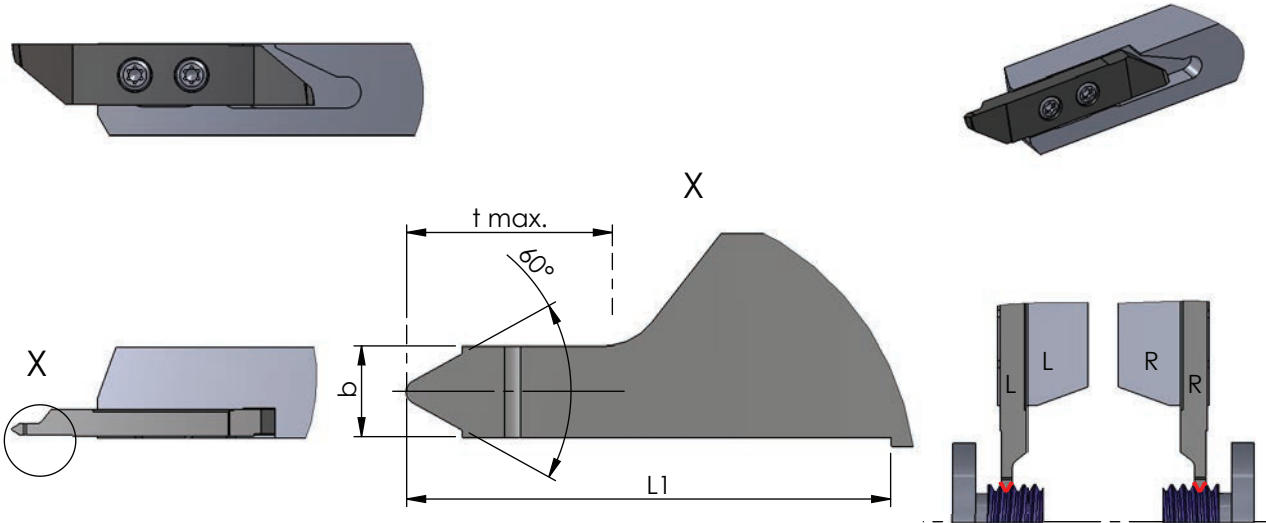

Rechts (R): wie gezeichnet  
Links (L): spiegelbildlich

Rechte Schneidpl. in rechtem Halter  
Linke Schneidpl. in linkem Halter

Abmessungen in mm

righthand version (R): as shown  
lefthand version (L): mirror image

use RH insert in RH tool holder and  
LH insert in LH tool holder

dimensions in mm

Bestellnummer part number	Gewindegröße thread size	Steigung P pitch P				K10F	CN45F	AL41F	P18C	Klemmhalter Typ toolholder type
			b	L1	t max.					
R/L ZW90.VP60025	M1 / M1.2	0.25	0.28	8	0	●			●	R/L HW10... R/L HW15... R/L HW20...
R/L ZW90.VP60030	M1.4	0.30	0.34	8	0	●			●	
R/L ZW90.VP60035	M1.6 / M1.8	0.35	0.38	8	0	●			●	
R/L ZW90.VP60040	M2	0.4	0.44	8	0	●			●	
R/L ZW90.VP60045	M2.2 / M2.5	0.45	0.50	8	0	●			●	
R/L ZW90.VP60050	M3	0.5	0.70	8	1.4	●			●	
R/L ZW90.VP60060	M3.5	0.6	0.80	8	1.4	●			●	
R/L ZW90.VP60070	M4	0.7	0.90	8	1.8	●			●	
R/L ZW90.VP60075	M4.5	0.75	0.90	8	1.9	●			●	

Weitere HM Sorten können Sie in der Sorten-  
übersicht im Kapitel "Technische Hinweise" und  
der Preisliste finden.

Bestellbeispiel:  
für rechte Ausführung und Sorte  
RZW90.VP60025/P18C

More carbide grades you can find in the grades  
summary in the chapter "technical instructions"  
and in the price list.

order example:  
righthand version and grade  
RZW90.VP60025/P18C

**BROTECH**

## SWISSLINE

Miniaturaußenbearbeitung,  
zweischneidig

miniature external machining,  
two-cutting edges

## Typ ZW90

Wendeschneidplatten,  
Gewindedrehen,  
Vollprofil, 60°

indexable inserts,  
threading,  
full profile, 60°

Gewinde M5 - M27  
Steigung P = 0.8 - 3

thread M5 - M27  
pitch P = 0.8 - 3

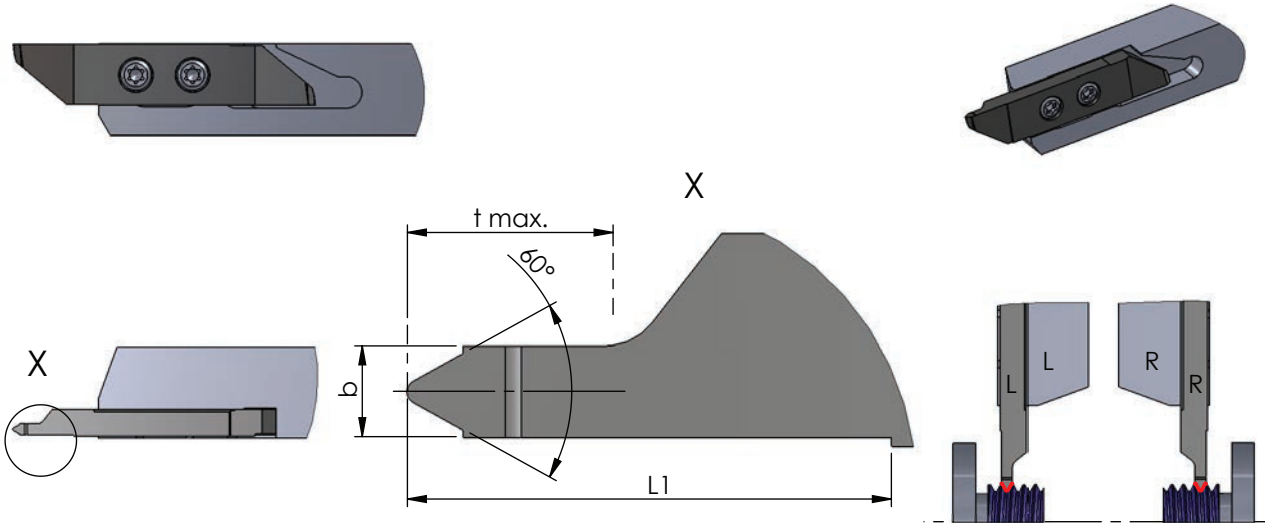

Rechts (R): wie gezeichnet  
Links (L): spiegelbildlich

Rechte Schneidpl. in rechtem Halter  
Linke Schneidpl. in linkem Halter

Abmessungen in mm

righthand version (R): as shown  
lefthand version (L): mirror image

use RH insert in RH tool holder and  
LH insert in LH tool holder

dimensions in mm



Bestellnummer part number	Gewindegröße thread size	Steigung P pitch P	b	L1	t max.					Klemmhalter Typ toolholder type
						K10F	CN45F	AL41F	P18C	
R/L ZW90.VP60080	M5	0.8	1.00	8	2.0	●			●	R/L HW10... R/L HW15... R/L HW20...
R/L ZW90.VP60100	M6 / M7	1.0	1.10	8	2.4	●			●	
R/L ZW90.VP60125	M8	1.25	1.46	8	2.9	●			●	
R/L ZW90.VP60150	M10 / M11	1.50	1.74	8	3.4	●			●	
R/L ZW90.VP60175	M12	1.75	1.96	8	3.9	●			●	
R/L ZW90.VP60200	M14 / M16	2.00	2.20	8	4.0	●			●	
R/L ZW90.VP60250	M18 / M20 / M22	2.50	2.80	8	5.0	●			●	
R/L ZW90.VP60300	M24 / M27	3.00		8	5.0	●			●	

Weitere HM Sorten können Sie in der Sorten-  
übersicht im Kapitel "Technische Hinweise" und  
der Preisliste finden.

Bestellbeispiel:  
für rechte Ausführung und Sorte  
RZW90.VP60080/P18C

More carbide grades you can find in the grades  
summary in the chapter "technical instructions"  
and in the price list.

order example:  
righthand version and grade  
RZW90.VP60080/P18C

## SWISSLINE

Miniatúraußenbearbeitung,  
zweischneidig

miniature external machining,  
two-cutting edges

## Typ ZW94

Wendeschneidplatten,  
Gewindedrehen,  
Teilprofil, 55° / 60°

indexable inserts,  
threading,  
partial profile, 55° / 60°

Steigung P = 0.25 - 2

pitch P = 0.25 - 2

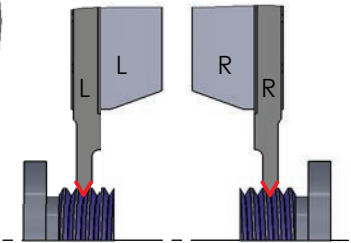
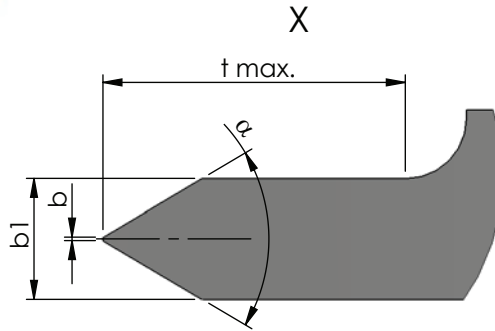
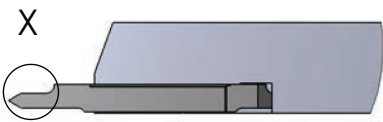
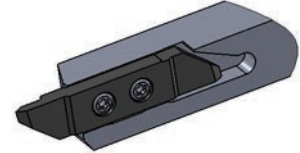

Rechts (R): wie gezeichnet  
Links (L): spiegelbildlich

Rechte Schneidpl. in rechtem Halter  
Linke Schneidpl. in linkem Halter

Abmessungen in mm

righthand version (R): as shown  
lefthand version (L): mirror image

use RH insert in RH tool holder and  
LH insert in LH tool holder

dimensions in mm

Bestellnummer part number	Steigung P pitch P	$\alpha$	t max.	b	b1					Klemmhalter Typ toolholder type
						K10F	CN45F	AL41F	P18C	
R/L ZW94.TP5506	0.25 - 2	55°	6	0.035	2	●			●	R/L HW10... R/L HW15... R/L HW20...
R/L ZW94.TP5510	0.25 - 2	55°	10	0.035	3	●			●	
R/L ZW94.TP6006	0.25 - 2	60°	6	0.035	2	●			●	
R/L ZW94.TP6010	0.25 - 2	60°	10	0.035	3	●			●	

Weitere HM Sorten können Sie in der Sorten-  
übersicht im Kapitel "Technische Hinweise" und  
der Preisliste finden.

Bestellbeispiel:  
für rechte Ausführung und Sorte  
RZW94.TP5506/P18C

More carbide grades you can find in the grades  
summary in the chapter "technical instructions"  
and in the price list.

order example:  
righthand version and grade  
RZW94.TP5506/P18C

**BROTECH**

## SWISSLINE

Miniaturaußenbearbeitung,  
zweischneidig

miniature external machining,  
two-cutting edges

## Technische Hinweise

Beschreibung der Schneidenausführungen

Technical instructions,  
Description of the cutting types

## Bezeichnung Schneide

Das Merkmal "vorne" und "hinten" bezieht sich nicht auf die Richtung der Bearbeitung, sondern zeigt an, auf welcher Seite eine senkrechte Flanke erstellt werden kann mit der entsprechenden Schneide.

### Description cutting edge

The description "front" or "back" means not the cutting direction, this shows the side which can produce an upright flank.

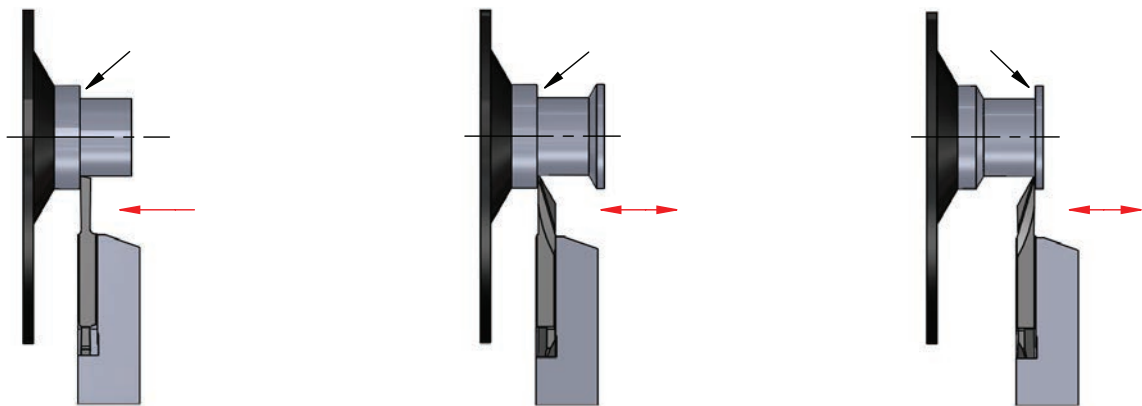

"VORNE"

"VORNE" kopieren

"HINTEN" kopieren

## Wiper-Geometrie

Durch Einsatz einer Schneide mit Wipergeometrie kann der Vorschub bis zum doppelten im Gegensatz zu einer Schneide mit normalem Eckenradius erhöht werden.

Durch die spezielle Geometrie der Schneide kann eine geringere Rautiefe trotz höherem Vorschub erreicht werden.

### Wiper geometry

By using the insert with wiper geometry the feed rate can be increased up to double time in contrast to an insert with standard radius.

The special geometry improves the surface quality by using a higher feed rate.

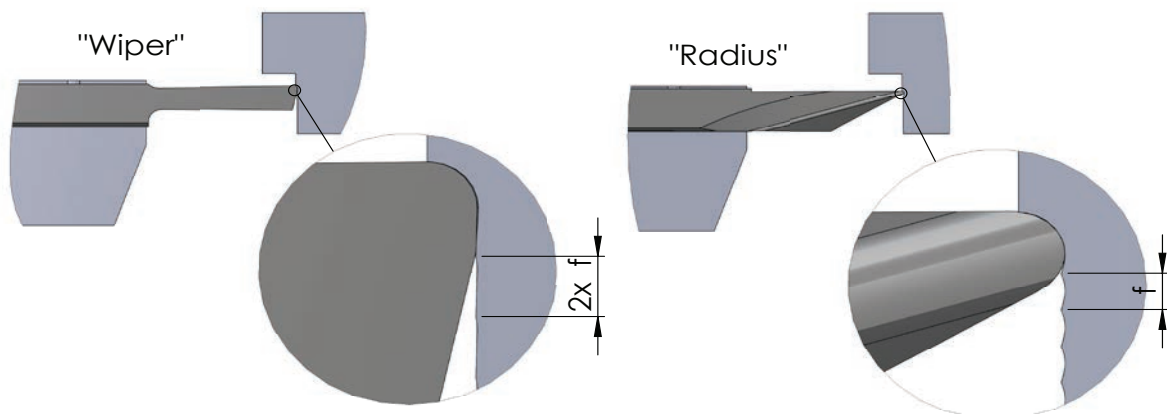

## SWISSLINE

Miniaturaußenbearbeitung,  
zweischneidig

miniature external machining,  
two-cutting edges

## Technische Hinweise

Allgemeine Informationen zum  
Gewindeschneiden

Technical instructions,  
General informations about threading

## Empfohlene Anzahl der Schnitte

Die Anzahl der Schnitte ist nur ein Richtwert für das Gewindedrehen. Um eine möglichst lange Standzeit der Schneide zu erreichen beachten Sie bitte die Erklärungen für die Zustellung.  
Leerschnitte zum Fertigschneiden sind in dieser Tabelle nicht berücksichtigt.

### Recommended number of passes

The number of passes is only a recommendation for threading. To reach a good tool life you have to mention the explanation for the infeed.  
Finishing passes are not considered in that chart.



		Stahl (Festigkeit N/mm <sup>2</sup> ) Steel (N/mm <sup>2</sup> tensile strength)					rostfreier Stahl stainless steel	Guss cast iron	Alumini- um alumini- um
		400-500	500-700	700-850	850-1150	>1150			
V m/min		160	140	120	90	70	90	100	300
Steigung P Pitch P		Anzahl der Schnitte number of passes							
mm	Gg/" TPI								
0,25 - 0,35	80/72	3 - 5	3 - 5	3 - 5	3 - 5	3 - 5	3 - 5	3 - 5	3 - 5
0,4	64	3 - 5	3 - 5	4 - 6	4 - 6	4 - 6	4 - 6	4 - 6	3 - 6
0,45	56	3 - 6	3 - 5	4 - 6	5 - 7	5 - 7	5 - 7	4 - 6	3 - 7
0,5	48/44	5 - 8	5 - 8	6 - 9	7 - 10	7 - 10	7 - 10	6 - 9	3 - 8
0,75	40/36	7 - 9	7 - 9	8 - 10	9 - 11	9 - 11	9 - 11	8 - 10	4 - 9
0,8	32	7 - 10	7 - 10	8 - 11	10 - 12	10 - 12	10 - 12	8 - 11	5 - 10
1	28/24	8 - 12	9 - 13	10 - 14	11 - 15	12 - 15	12 - 15	10 - 14	6 - 11
1,25	20/19	10 - 15	11 - 16	12 - 17	14 - 18	15 - 18	15 - 18	12 - 17	7 - 14
1,5	18/16	11 - 18	12 - 19	15 - 20	16 - 21	18 - 22	18 - 22	15 - 20	8 - 16
1,75	14	12 - 20	13 - 21	15 - 22	18 - 23	20 - 24	20 - 24	15 - 22	8 - 16
2-2,5	13/11	15 - 24	16 - 25	18 - 26	20 - 27	22 - 28	22 - 28	18 - 26	17- 22

## SWISSLINE

Miniatöraußenbearbeitung,  
zweischneidig

miniature external machining,  
two-cutting edges

## Technische Hinweise

Allgemeine Informationen zum  
Gewindeschneiden

Technical instructions,  
General informations about threading

## Vorschubrichtung

Mit jedem Schneideinsatz für das Gewindedrehen kann sowohl ein Rechts- wie auch ein Linksgewinde geschnitten werden. Hierbei ist folgende Vorschubrichtung zu beachten:

### Feed direction

Every insert can be used for right- and lefthand thread. You only have to consider the following feed direction:

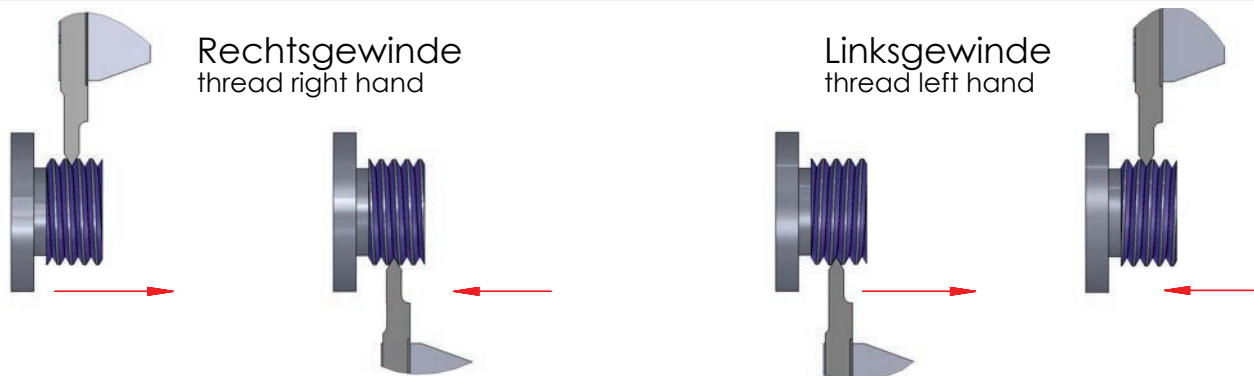

## Zustellungsvarianten

Radiale Zustellung	wechselnde Flankenzustellung	einseitige Flankenzustellung
Die meist verwendete Methode um Gewinde herzustellen. Beide Schneiden sind gleichzeitig im Eingriff.	Die Schneiden werden wechselnd eingesetzt.	Nur eine Schneide wird für die komplette Gewindeerstellung eingesetzt.
Problematische Spanbildung, dadurch hohe Schnittkräfte und Verschleiß am Werkzeug und Bauteil.	Reduzierung des Schnittdrucks, höhere Standzeit und bessere Spanbildung.	Reduzierung des Schnittdrucks und bessere Spanbildung, aber einseitige Abnutzung des Werkzeugs.

### Infeed possibilities

Radial infeed	alternating flank infeed	flank infeed
The most used method for threading, both sides are at the same time in process.	The flanks are alternating used.	Only one cutting edge is used for the complete thread.
Problematic chip education, high cutting force and weariness at insert and work piece.	Reduced cutting force, higher state time and chip education.	Reduced cutting force and better chip education, but one-sided weariness.

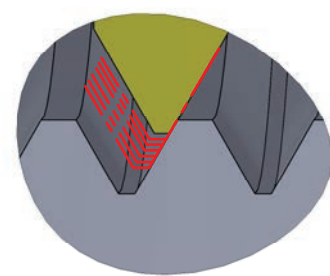
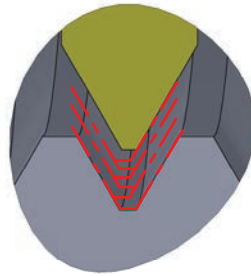
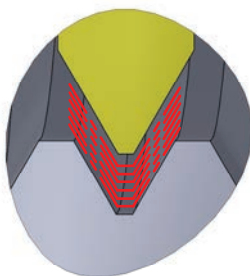

## SWISSLINE

Miniaturaußenbearbeitung,  
zweischneidig

miniature external machining,  
two-cutting edges

## Technische Hinweise

Hartmetallsorten und Beschichtungen

Technical instructions,  
carbide grades and coatings

### K10F

Universell einsetzbares Feinkornhartmetall mit guter Verschleißfestigkeit. Unbeschichtet geeignet für Anwendungen mit niedrigen und mittleren Schnittgeschwindigkeiten, sowie die Bearbeitung von Nicht-eisenmetallen.

All purpose micrograin carbide with good abrasion resistance. Uncoated for applications with low or medium cutting speeds and machining of non-ferrous materials.

### CBN

Zähe CBN-Sorte für Anwendungen mit niedrigen Schnittgeschwindigkeiten. Geeignet für gehärtete Stähle, unterbrochene Schnitte und Grauguss.

Ductile CBN grade for applications with lower cutting speed. Suitable for hardened steel, interrupted cuts and cast iron.

### CN45F

Universell einsetzbare PVD-TiN-Beschichtung. Diese Allround-Sorte ist für niedrige und mittlere Schnittgeschwindigkeiten mit Einschränkung bei NE-Metallen

PVD-TiN coating - all purpose, all around grade is suitable for low and medium cutting speed with restrictions on non-ferrous materials.

### AL41F

Sehr universell einsetzbare TiAlN-Beschichtung mit hoher Temperaturbeständigkeit bei hoher Härte. Sehr gut geeignet auch für NE-Metalle.

TiAlN coating - very universal with a high resistance to high temperature and hardness. Very suitable also for non-ferrous metals.

### PD2F

Beschichtung für den universellen Einsatz bei niedrigen und mittleren Schnittgeschwindigkeiten.

Coating for universal use with medium and low speed.

### XC2A

Beschichtung mit einer excellenten Warmhärte, Oxidationsbeständigkeit und thermischen Isolationsfähigkeit. Ideal für Hartzerspannung >60HRC

Coating with excellent hot hardness, high oxidation resistance and thermal insulation capacity. Perfect for hard machining >60 HRC.



## SWISSLINE

Miniaturaußenbearbeitung,  
zweischneidig

miniature external machining,  
two-cutting edges

## Technische Hinweise

Hartmetallsorten und Beschichtungen

Technical instructions,  
carbide grades and coatings

### P01C

Beschichtung für die Bearbeitung in zähen Materialien bei niedrigen und mittleren Schnittgeschwindigkeiten.

Coating for the processing in tough material with medium or low cutting speed

### P03C

Beschichtung für die Bearbeitung von schwer zerspanbaren Materialien. Sehr gut auch für die Trockenbearbeitung geeignet.

Coating for materials which are difficult to machine. Perfect to use for dry machining.

### P07C

Beschichtung für die Bearbeitung von Titan, Edelstahl und Molybdän.

Coating to machine titanium, stainless steel and molybdenum.

### P18C

Universell einsetzbare Hochleistungsschicht mit hoher Oxidationsbeständigkeit, Verschleißfestigkeit und Warmhärte.

Very universal high performance coating with high oxidation resistance, wear resistance and hot hardness resistance.

### NEME

Beschichtung für die Bearbeitung von Aluminium, Al-Legierungen, NE-Metallen und Composite-Werkstoffen.

Coating for machining aluminium, alloys, non-ferrous metals and composite materials.





# SWISSLINE

Miniatúraußenbearbeitung,  
zweischneidig

miniature external machining,  
two-cutting edges

# Technische Hinweise

Schnittdaten

Technical instructions,  
cutting data



	Werkstoff	Festigkeit	Werkstoff-Nr	Werkstoffbezeichnung	Werkstoff-Nr
P	Allgemeiner Baustahl	< 800 N/mm2	1.0037	St37-2	1.0570
	Automatenstahl	< 800 N/mm2	1.0718	9SMnPb28	1.0727
	Einsatzstahl unlegiert	< 800 N/mm2	1.0401	C15	1.0481
	Einsatzstahl legiert	< 1000 N/mm2	1.7331	16MnCr5 (EC80)	1.7015
	Vergütungsstahl unlegiert	< 850 N/mm2	1.0503	C45	1.1191
	Vergütungsstahl unlegiert	< 1000 N/mm2	1.0601	C60	1.1221
	Vergütungsstahl legiert	< 800 N/mm2	1.5131	50MnSi4	1.7030
	Vergütungsstahl legiert	< 1300 N/mm2	1.5755	31NiCr14	1.7033
	Stahlguss	< 850 N/mm2	0.9650	G-X260Cr27	1.6750
	Nitrierstahl	< 1000 N/mm2	1.8504	34CrAl6	1.8507
	Nitrierstahl	< 1200 N/mm2	1.8515	31CrMo12	1.8523
	Wälzlagerstahl	< 1200 N/mm2	1.3505	100Cr6 (W3)	1.3543
	Federstahl	< 1200 N/mm2	1.5026	55Si7	1.7176
	Schnellarbeitsstahl	< 1300 N/mm2	1.3344	S 6-5-3	1.3255
	Werkzeugstahl für Kaltarbeit	< 1300 N/mm2	1.2312	40CrMnMoS8 6	1.2379
	Werkzeugstahl für Warmbeit	< 1300 N/mm2	1.2343	X38CrMoV 5 1	1.2767
M	Stahl und Stahlguss rostfrei geschwefelt	< 850 N/mm2	1.4305	X8CrNiS18 9	1.4105
	Nichtrostender Stahl, ferritisch	< 750 N/mm2	1.4510	X3CrTi17	1.4528
	Nichtrostender Stahl, martensitisch	< 900 N/mm2	1.4034	X46Cr13	1.4116
	Nichtrost. Stahl, ferritisch/martensit.	<1100 N/mm2	1.4313	X3CrNi13-4	1.4028
	Nichtrost. Stahl, austenitisch/ferritisch	< 850 N/mm2	1.4460	X8CrNiMo27 5	1.4821
	Nichtrostender Stahl, austenitisch	< 750 N/mm2	1.4301	X5CrNi18-10	1.4571
	Hitzebeständig	< 1100 N/mm2	1.4747	X80CrNiSi20	1.4876
K	Grauguss mit Lammellengraphit	100-350N/mm2	0.6010	GG10	0.6025
	Grauguss mit Lammellengraphit	300-1000N/mm2	0.6030	GG30	0.6045
	Kugelgraphitguss	300-500N/mm2	0.7040	GGG40	0.7050
	Kugelgraphitguss	550-800N/mm2	0.7060	GGG60	0.7080
	Temperguss weis	350-450N/mm2	0.8035	GTW35	0.8045
	Temperguss weis	500-650N/mm2	0.8055	GTW55	0.8065
	Temperguss schwarz	350-450N/mm2	0.8135	GTS35	0.8145
	Temperguss schwarz	500-700N/mm2	0.8155	GTS55	0.8170
N	Aluminium ( unlegiert, niedrig legiert )	< 350 N/mm2	3.0255	Al99,5	3.3308
	Aluminiumlegierungen < 0,5% Si	< 500 N/mm2	3.0515	AlMn1	3.1355
	Aluminiumlegierungen 0,5-10% Si	< 400 N/mm2	3.2152	GD-AlSi6Cu4	3.2373
	Aluminiumlegierungen 10-15% Si	< 400 N/mm2	3.2381	G-AlSi10Mg	3.5562
	Aluminiumlegierungen > 15% Si	< 400 N/mm2		G-AlSi17Cu4	
	Kupfer ( unlegiert, niedrig legiert )	< 350 N/mm2	2.0060	E-Cu57	2.0090
	Kupfer-Knetlegierungen	< 700 N/mm2	2.0240	CuZn15	2.0265
	Kupfer-Sonderlegierungen	< 200 HB	2.0916	CuAl5	2.1525
	Kupfer-Sonderlegierungen	< 300HB	2.0978	CuAl11Ni6Fe5	
	Kupfer-Sonderlegierungen	> 300 HB	2.1247	CuBe2F125	
	Messing kurzspanend, Bronze, Rotguss	< 600 N/mm2	2.0360	CuZn40 (Ms60)	2.0380
	Messing langspanend	< 600 N/mm2	2.0335	CuZn36 (Ms63)	2.1293
	Thermoplaste			Delrin, Hostalen	
	Duroplaste			Ferrozell, Bakelit	
	Faserverstärkte Kunststoffe			GFK (Glasfaserverstärkt )	
	Magnesium und Magnesiumlegierungen	< 850 N/mm2	3.5200	M2, MgMn2	3.5612
	Graphit			C8000, R8500X	
	Wolfram und Wolframlegierungen			W-NiFe (Densimet W)	
	Molybdän und Molybdänlegierungen			Mo , Mo-50Re	
	S	Reinnickel		1.3911	RNi24
Nickellegierungen			1.3912	Ni36 (Invar)	1.3924
Nickellegierungen		< 850 N/mm2	2.4360	S-NiCu 30 Fe	
Nickel-Chromlegierungen			2.4886	SG-NiMo16Cr16W	2.4610
Nickel- und Kobaltlegierungen		< 1300 N/mm2	2.4632	NiCr20Co18Ti	2.4631
Nickel- und Kobaltlegierungen		< 1300 N/mm2	2.4634	NiCo20Cr15MoAlTi	2.4654
Hochwarmfeste Legierungen		< 1300 N/mm2		Hardox 400	1.4939
Nickel-Kobalt-(Chrom-)legierungen		< 1400 N/mm2	2.4806	SG-NiCr20Nb, Inconel 82	2.4851
Reintitan		< 900 N/mm2	3.7025	Ti99,8	3.7034
Titanlegierungen		< 700 N/mm2	3.7114	TiAl5Sn2	3.7174
Titanlegierungen		< 1200 N/mm2	3.7164	TiAl5V4	3.7144
H	Stahl gehärtet	< 45 HRc			
		46-55HRc			
		56-60 HRc			
		61-65 HRc			
	65-70 HRc				

# SWISSLINE

Miniaturaußenbearbeitung,  
zweischneidig

miniature external machining,  
two-cutting edges

# Technische Hinweise

Schnittdaten

Technical instructions,  
cutting data

Werkstoffbezeichnung	Werkstoff-Nr	Werkstoffbezeichnung	Vc K10F ( m/min. )	Vc P18C ( m/min. )	Bearbeitung	ap (mm)	f (mm/U)			
St52-3	1.0060	St60-2	50-120	100-240	▼ ▼▼ ▼▼▼	< 4 < 2,5 < 1,5	0,1-0,25 0,02-0,15 0,005-0,08			
45S20	1.0757	46SPb2	50-120	100-240						
17Mn4	1.1141	C15E (CK15)	50-120	100-240						
13Cr3 (EC60)	1.5919	15CrNi6	60-120	80-220						
Ck45	1.0535	C55	60-120	80-220						
Ck60	1.0540	C50	60-120	80-220						
28Cr4	1.7225	42CrMo4	60-120	80-220						
34Cr4	1.3565	48CrMo4	60-120	80-220						
GS-20NiCrMo3 7	1.6582	GS-34 CrNiMo 6	60-120	80-220						
34AlMo5	1.8509	41CrAlMo7	40-100	80-200						
39CrMoV19 3	1.8550	34 CrAlNi 7	40-100	80-200						
X192CrMo17	1.3520	100 CrMn 6 (W4)	40-100	80-200						
55Cr3	1.7701	51CrMoV4		50-120						
S 18-1-2-5	1.3294	PMH56-5-3-8; ASP30		50-120						
X155CrVMo12 1	1.2316	X38CrMo16; RAMAX		40-100						
X45NiCrMo4	1.2842	90MnCrV8		40-100						
X4CrMoS18	1.4107	GX8CrNi12	40-80	80-180	▼ ▼▼ ▼▼▼	< 4 < 2,5 < 1,5	0,1-0,2 0,02-0,12 0,005-0,08			
X105CrCoMo18 2	1.4016	X6Cr17	40-80	80-180						
X50CrMoV15	1.4106	X2CrMoSi18-2-1	40-80	80-180						
X30Cr13	1.4104	X14CrMoS17	30-65	50-100						
X20CrNiSi25 4	1.4462	X2CrNiMoN22-5-3 (Duplex)	30-65	50-100						
X6CrNiMoTi17 12 2	1.4449	X3CrNiMo18-12-3	30-65	50-100						
X10NiCrAlTi32-21	1.4825	GX25CrNiSi18-9	30-65	50-100						
GG25			30-110	30-180						
GG45			30-90	30-150						
GGG50			25-110	30-180						
GGG80			25-80	30-120						
GTW45			20-40	30-90	▼ ▼▼ ▼▼▼	< 4 < 2,5 < 1,5	0,1-0,25 0,02-0,15 0,005-0,08			
GTW65			20-40	20-80						
GTS45			20-40	30-90						
GTS70			20-40	20-80						
A199,9Mg0,5	3.0256	E-Al H	120-500	120-600				▼ ▼▼ ▼▼▼	< 5 < 3 < 2	0,1-0,3 0,02-0,2 0,005-0,12
AlCuMg2	3.3315	AlMg1	120-500	120-600						
GD-AlSi9Mg	3.2134	GD-AlSi5Cu1Mg	100-400	100-450						
G-MgAl6	3.2525	S-AlSi12	70-250	70-300						
G-AlSi25CuNiMg		G-AlSi21CuNiMg	60-140	60-150						
SF-Cu	2.1522	CuSi2Mn	60-140	60-150						
CuZn30	2.0321	CuZn37	100-160	100-180						
CuSi3Mn		Ampco 8-16	90-160	90-180						
		Ampco18-26	80-160	80-180						
		Ampco M-4	80-160	80-180						
CuZn39Pb2 (Ms58)	2.0410	CuZn44Pb2	120-200	120-220						
CuCrZr	2.1080	CuSn6Zn6	70-140	70-150						
Makrolon, Novodur		Acrylglas, Polystyrol	80-160	80-180						
Pertinax		Resopal	80-160	80-180						
CFK (Kohlefaserverstärkt)		AFK (Amidfaserverstärkt)		80-180						
MgAl6Zn1	3.5812	MgAl8Zn1		80-180						
R8650		Technograph15		80-180						
W-Cu80/20		W93NiFe (DENAL)		80-180						
TZC, TZM		MHC, ODS		80-180						
RNi8	1.3926	RNi12		30-80	▼ ▼▼ ▼▼▼	< 4 < 2,5 < 1,5	0,1-0,25 0,02-0,08 0,005-0,06			
Ni54	1.3921	Ni49		18-75						
NiCu 30 Fe		Monel 400		18-75						
NiMo16Cr16Ti		Hastelloy C-276		18-40						
NiCr20TiAl		Nimonic 80		18-40						
NiCr19Co14Mo4Ti		Waspaloy		18-40						
X12CrNiMo12	1.4980	X6NiCrTiMoVB25-15-2		15-30						
NiCr23Fe, Inconel 601	2.4667	SG-NiCr19NbMoTi		15-30						
Ti99,7	3.7064	Ti99,5		15-30						
TiAl6V6Sn2	3.7124	TiCu2		100-150						
TiAl6Sn2Zr4Mo2	3.7154	TiAl6Zr5		100-150						



f: (mm/U) ≙ (mm/Rev.)





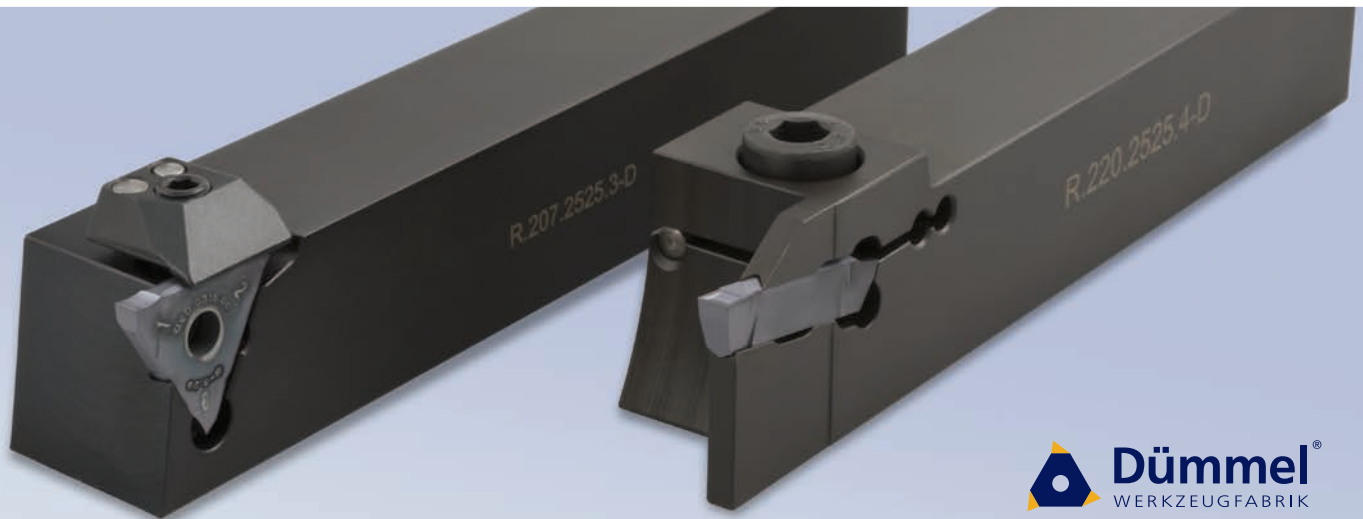

## STECHDREH-WERKZEUGE



**SYSTEM DED:** Einstechen dreischneidig  
**SYSTEM ZTP:** Einstechen zweischneidig

**system DED:** grooving with three-cutting edges  
**system ZTP:** grooving with two-cutting edges

## SYSTEM DED

Einstecken mit dreischneidigen Wendeplatten

grooving with three-cutting edges indexable inserts

## Übersicht

summary

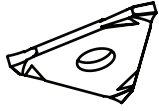

Allgemeine Beschreibung

general instructions

... 236

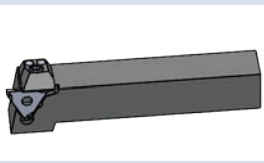

**Klemmhalter**

**toolholder**

**Maße  
dimensions**

**Seite  
page**

**Typ .207**

Klemmhalter,  
Außenbearbeitung

toolholder,  
external application

Spannbereich  
holding capacity  
S 0.5 - 6.5 mm  
t max. 4 / 6

... 237

**Typ .0.780**

Klemmhalter,  
Außenbearbeitung

toolholder,  
external application

Spannbereich  
holding capacity  
S 1.9 - 6.5 mm  
t max. 8

... 239

**Typ .0.738**

Klemmhalter, gekröpft  
Außenbearbeitung

toolholder, cranked,  
external application

Spannbereich  
holding capacity  
S 0.5 - 6.5 mm  
t max. 6

... 240

**Typ .0.618**

Klemmhalter,  
für Eckenfreistriche,  
Außenbearbeitung

toolholder,  
for corner reliefs,  
external application

Spannbereich  
holding capacity  
S 1.9 - 6.5 mm

... 241

**Typ .0.660**

Bohrstange,  
Innenbearbeitung

grooving boring bar,  
internal application

Spannbereich  
holding capacity  
S 0.5 - 6.5 mm  
D min. 46

... 242

**Typ .0.736**

Klemmhalter,  
zum Abstechen,  
Außenbearbeitung

toolholder,  
for parting off,  
external application

Stechbreite  
width of groove  
S 0.5 - 1.2 mm  
t max. 8

... 243

## SYSTEM DED

Einstecken mit dreischneidigen Wendeplatten

grooving with three-cutting edges indexable inserts

## Übersicht

summary



### Wendeschneidplatten Stechdrehen

### indexable inserts grooving

### Maße dimensions

### Seite page

<b>Typ Stechdrehen</b>	für Sicherungsringe DIN 471/472 und Stechdrehen allgemein	type grooving for circlips DIN 471/472 and general grooving	Stechbreite width of groove S 0.57 - 5.29 mm	... 244
<b>Typ Stechdrehen</b>	für unterbrochene Schnitte und Sicherungsringe DIN 471/472	type grooving interrupted cuts, and circlips DIN 471/472	Stechbreite width of groove S 1.07 - 5.29 mm	... 246
<b>Typ Stechdrehen</b>	für Sicherungsringe DIN 471/472, stabile Ausführung	type grooving for circlips DIN 471/472, solid construction	Stechbreite width of groove C 0.55 - 1.05 mm	... 247
<b>Typ Stechdrehen</b>	für Sicherungsringe DIN 471/472, mit Nutaußenkantenfasung	type grooving for circlips DIN 471/472, with chamfer	Stechbreite width of groove C 1.24 - 5.29 mm	... 248
<b>Typ Stechdrehen</b>	zum Feindreihen	type grooving for finishing	Stechbreite width of groove S 1.0 - 4.0 mm	... 250
<b>Typ Stechdrehen</b>	Vollradius, für Nuten und Eckenfreistich	type grooving full radius, for grooving and corner reliefs	Stechbreite width of groove S 0.5 - 5.0 mm	... 251
<b>Typ Stechdrehen</b>	mit Spanformer, zum Abstechen	type grooving with chipformer for parting off	Stechbreite width of groove S 1.99 - 2.79 mm	... 252
<b>Typ Stechdrehen</b>	ohne Spanformer, zum Abstechen	type grooving without chipformer for parting off	Stechbreite width of groove S 0.5 - 1.4 mm	... 253
<b>Typ Stechdrehen</b>	zum Einstecken und Längsdrehen	type grooving for grooving and turning	Stechbreite width of groove C 3.29 mm t max. 3.5	... 254
<b>Typ Stechdrehen</b>	für Eckenfreistich, ähnlich DIN 509 Form F	type grooving for corner reliefs, similar to DIN 509 type F	Stechbreite width of groove S 2.4 - 5.0 mm	... 255
<b>Typ Stechdrehen</b>	Axialbearbeitung	type grooving, face grooving	Stechbreite width of groove C 1.5 - 5.0 mm t max. 3.5	... 256



## SYSTEM DED

Einstecken mit dreischneidigen Wendeplatten

grooving with three-cutting edges indexable inserts

## Übersicht

summary



### Sets System DED

Halter (Rechte Ausführung) und Schneiden

### sets system DED

toolholder (righthand version) and inserts

### Maße dimensions

### Seite page

#### SET-DED 1

- für Sicherungsringe DIN 471 / 472 und Stechdrehen allgemein

- for circlips DIN 471 / 472 and general grooving

Stechbreite width of groove S 0.57 - 1.99 mm

... 257

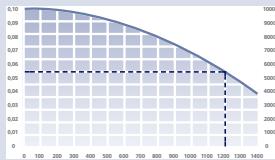

### Technische Hinweise

### Technical Instructions

### Seite page

Hartmetallsorten und Beschichtungen

carbide grades and coatings

... 273

Schnittdaten

cutting data

... 275

## SYSTEM ZTP

Einstecken mit  
zweischneidigen Wendeplatten

grooving with two-cutting  
edges indexable inserts

## Übersicht

summary

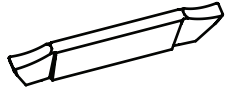

Allgemeine Beschreibung

general instructions

... 259

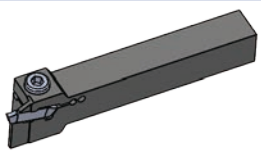

**Klemmhalter**

**toolholder**

**Maße  
dimensions**

**Seite  
page**

**Typ .212**

Klemmhalter,  
Außenbearbeitung

toolholder,  
external application

Spannbereich  
holding capacity  
S 2.0 - 6.0 mm  
t max. 12

... 260

**Typ .220**

Klemmhalter,  
Außenbearbeitung

toolholder,  
external application

Spannbereich  
holding capacity  
S 2.0 - 6.0 mm  
t max. 20

... 261

**Typ .225**

Klemmhalter,  
Außenbearbeitung

toolholder,  
external application

Spannbereich  
holding capacity  
S 2.0 - 6.0 mm  
t max. 25

... 262

**Typ .0.428**

Bohrstange,  
Innenbearbeitung

grooving boring bar,  
internal application

Spannbereich  
holding capacity  
S 2.0 - 6.0 mm  
t max. 15

... 263

**Typ .280**

Klemmhalter,  
Axialbearbeitung

toolholder,  
face grooving

Spannbereich  
holding capacity  
S 4.0 - 6.0 mm  
t max. 8

... 264

**Typ .281**

Klemmhalter,  
Axialbearbeitung

toolholder,  
face grooving

Spannbereich  
holding capacity  
S 4.0 - 6.0 mm  
t max. 8.5

... 265





## SYSTEM ZTP

Einstecken mit  
zweischneidigen Wendeplatten

grooving with two-cutting  
edges indexable inserts

## Übersicht

summary

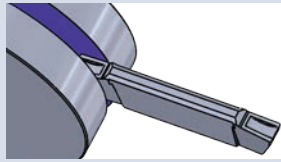

**Wendeschneidplatten  
Stechdrehen**

**indexable inserts  
grooving**

**Maße  
dimensions**

**Seite  
page**

<b>Typ Stechdrehen ....10</b>	mit runder Spannutt	type grooving, with round chipbreaker	Stechbreite width of groove S 2.0 - 6.0 mm	<b>... 266</b>
<b>Typ Stechdrehen ....20</b>	mit ebener Spanfläche	type grooving, with flat chipbreaker	Stechbreite width of groove S 2.0 - 6.0 mm	<b>... 267</b>
<b>Typ Stechdrehen ....30</b>	mit Spanformer	type grooving, with chipformer	Stechbreite width of groove S 2.0 - 6.0 mm	<b>... 268</b>
<b>Typ Stechdrehen ZTP.R</b>	mit Vollradius, und runder Spannutt	type grooving, with full radius and round chipbreaker	Stechbreite width of groove S 2.0 - 6.0 mm	<b>... 269</b>
<b>Typ Stechdrehen / Abstechen</b>	mit Spanformer	type grooving, with chipformer, for parting off	Stechbreite width of groove S 2.0 - 4.0 mm	<b>... 270</b>
<b>Typ Stechdrehen / Längsdrehen</b>	mit Spanformer	type grooving, with chipformer, grooving and turning	Stechbreite width of groove S 3.0 - 6.0 mm	<b>... 271</b>
<b>Typ Stechdrehen / Axialbearbeitung</b>	mit Spanformer	type grooving, with chipformer, face grooving	D min. 40 Stechbreite width of groove S 4.0 - 6.0 mm,	<b>... 272</b>

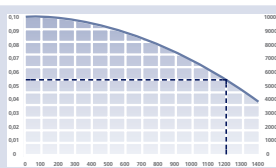

**Technische Hinweise**

**Technical Instructions**

**Seite  
page**

Hartmetallsorten und Beschichtungen carbide grades and coatings **... 273**

Schnittdaten cutting data **... 275**

## SYSTEM DED

Einstecken mit  
dreischneidigen Wendeplatten

grooving with three-cutting  
edges indexable inserts

## Allgemeine Beschreibung

general instruction



### System DED:

Das bewährte System zum Einstecken und Abstecken ab 0.5 mm Breite.

#### System DED:

Proven system for grooving and turning off from a width of 0.5 mm starting.

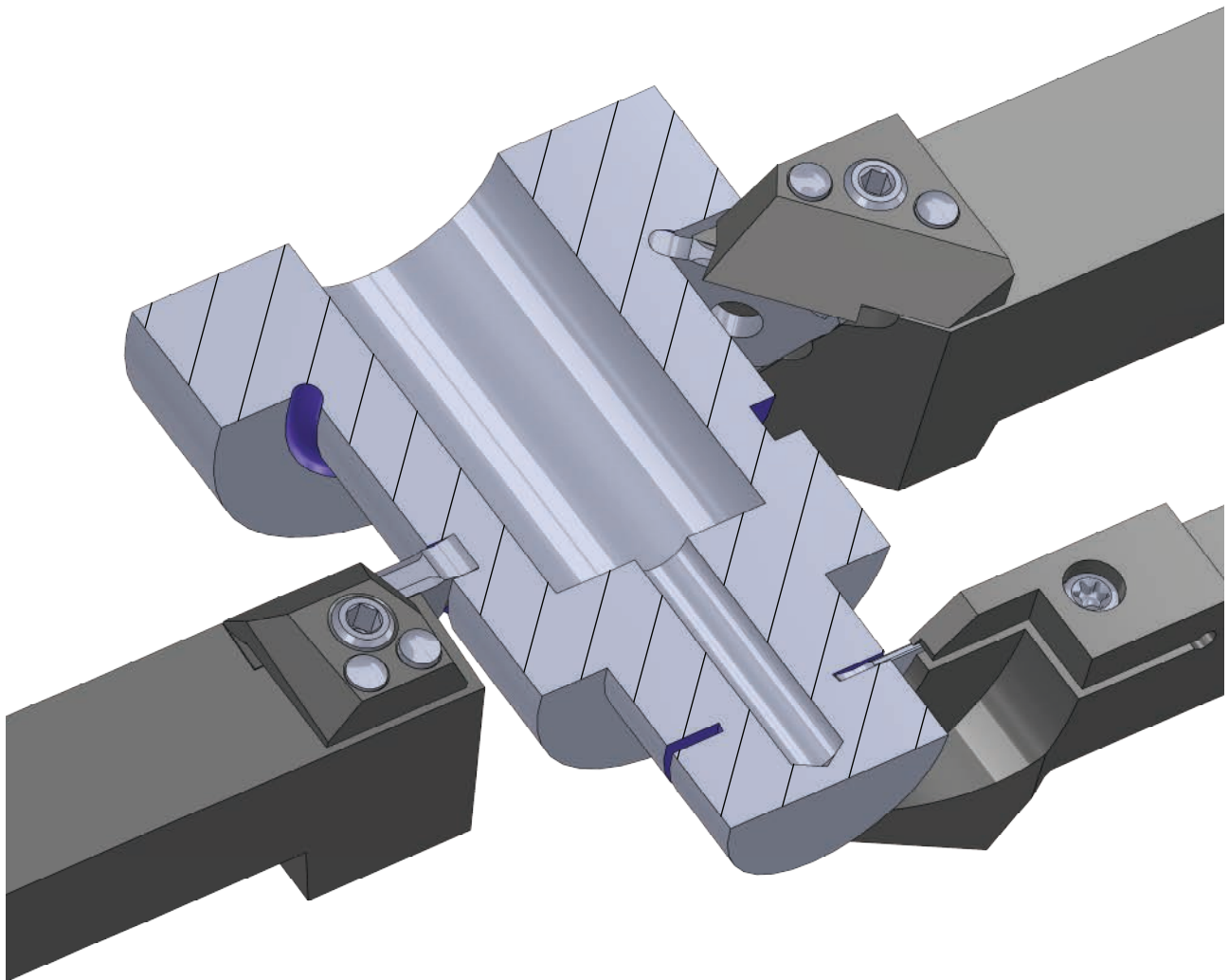

## SYSTEM DED

Einstecken mit dreischneidigen Wendepplatten

grooving with three-cutting edges indexable inserts

## Typ .207

Klemmhalter, Außenbearbeitung

toolholder, external application

Stechtiefe t max. 6 mm  
Spannbereich S 0.5 - 6.5 mm

depth of groove t max. 6 mm  
holding capacity S 0.5 - 6.5 mm

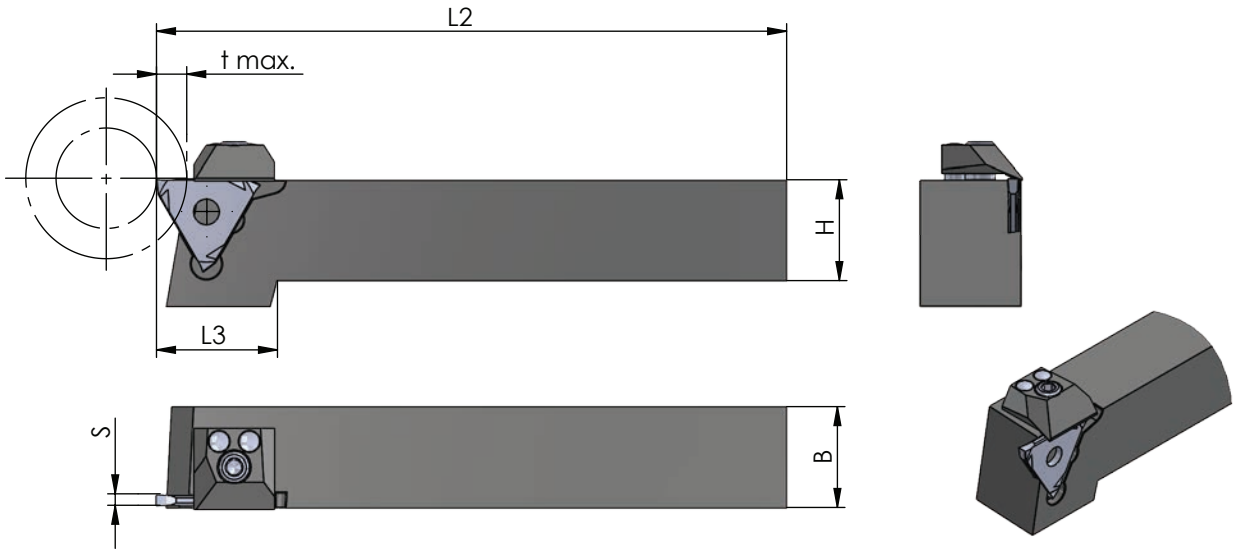

Rechts (R): wie gezeichnet  
Links (L): spiegelbildlich

righthand (R): as shown  
lefthand version (L): mirror image

Abmessungen in mm

dimensions in mm

Bestellnummer part number	H	B	H x B (inch)	*t max.	L2	L3	Spannpratze claw	Spannschraube screw	Führungsstifte guide pin	Spannbereich S holding capacity S	Wende- schneidplatte S indexable insert S
R/L .207.1212.1-D	12	12		4	100	28	R.207. ... : PD21/R L.207. ... : PD21/L	ZT200	6325	0.5 - 2.0	
R/L .207.1616.1-D	16	16		4	125	26					
R/L .207.2020.1-D	20	20		4	125	23					
R/L .207.2525.1-D	25	25		4	150	-					
R/L .207.U.1000.1-D	25.4	25.4	1"x1"	4	150	-					
R/L .207.3232.1-D	32	32		4	170	-				1.9 - 3.0	
R/L .207.1212.2-D	12	12		6	100	28					
R/L .207.1616.2-D	16	16		6	125	26					
R/L .207.2020.2-D	20	20		6	125	23					
R/L .207.2525.2-D	25	25		6	150	-					
R/L .207.3232.2-D	32	32		6	170	-					
↳ ...											

\*tmax. reduziert bei Werkstück Ø > 40  
\*tmax. reduced for workpiece Ø > 40

Spitzenhöhe JS14

center height JS14

Bestellbeispiel:  
für rechte Ausführung  
R.207.1212.1-D

order-example:  
righthand version  
R.207.1212.1-D



# SYSTEM DED

Einstecken mit dreischneidigen Wendeplatten

grooving with three-cutting edges indexable inserts

# Typ .207

Klemmhalter, Außenbearbeitung

toolholder, external application

Stechtiefe t max. 6 mm  
Spannbereich S 0.5 - 6.5 mm

depth of groove t max. 6 mm  
holding capacity S 0.5 - 6.5 mm

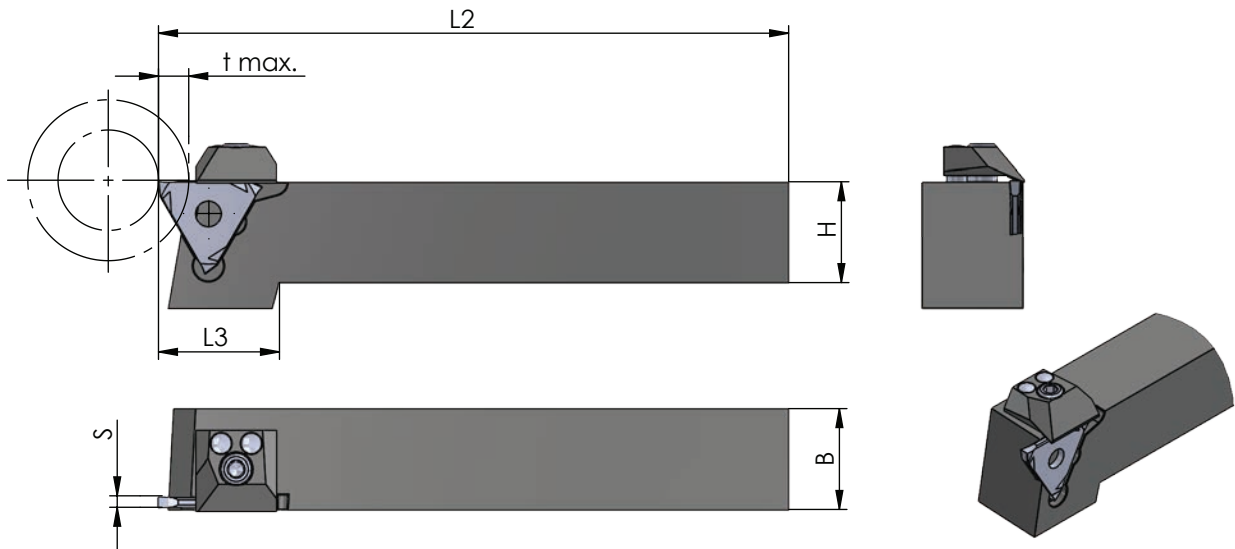

Rechts (R): wie gezeichnet  
Links (L): spiegelbildlich

righthand (R): as shown  
lefthand version (L): mirror image

Abmessungen in mm

dimensions in mm



Bestellnummer part number	H	B	H x B (inch)	*t max.	L2	L3	Spannpratze claw	Spannschraube screw	Führungsstifte guide pin	Spannbereich S holding capacity S	Wende- schneidplatte S indexable insert S
R/L .207.1212.3-D	12	12		6	100	28					
R/L .207.1616.3-D	16	16		6	125	26					
R/L .207.2020.3-D	20	20		6	125	23		ZT200	6325	2.9 - 4.0	
R/L .207.2525.3-D	25	25		6	150	-					
R/L .207.3232.3-D	32	32		6	170	-					
R/L .207.1616.4-D	16	16		6	125	26					
R/L .207.2020.4-D	20	20		6	125	23					
R/L .207.2525.4-D	25	25		6	150	-		ZT200	6325	3.9 - 6.5	
R/L .207.3232.4-D	32	32		6	170	-					

\*tmax. reduziert bei Werkstück Ø > 40  
\*tmax. reduced for workpiece Ø > 40

Spitzenhöhe JS14

center height JS14

Bestellbeispiel:  
für rechte Ausführung  
R.207.1212.3-D

order-example:  
righthand version  
R.207.1212.3-D



## SYSTEM DED

Einstecken mit dreischneidigen Wendeplatten

grooving with three-cutting edges indexable inserts

## Typ .0.780

Klemmhalter, Außenbearbeitung

toolholder, external application

Stechtiefe t max. 8 mm  
Spannbereich S 1.9 - 6.5 mm

depth of groove t max. 8 mm  
holding capacity S 1.9 - 6.5 mm

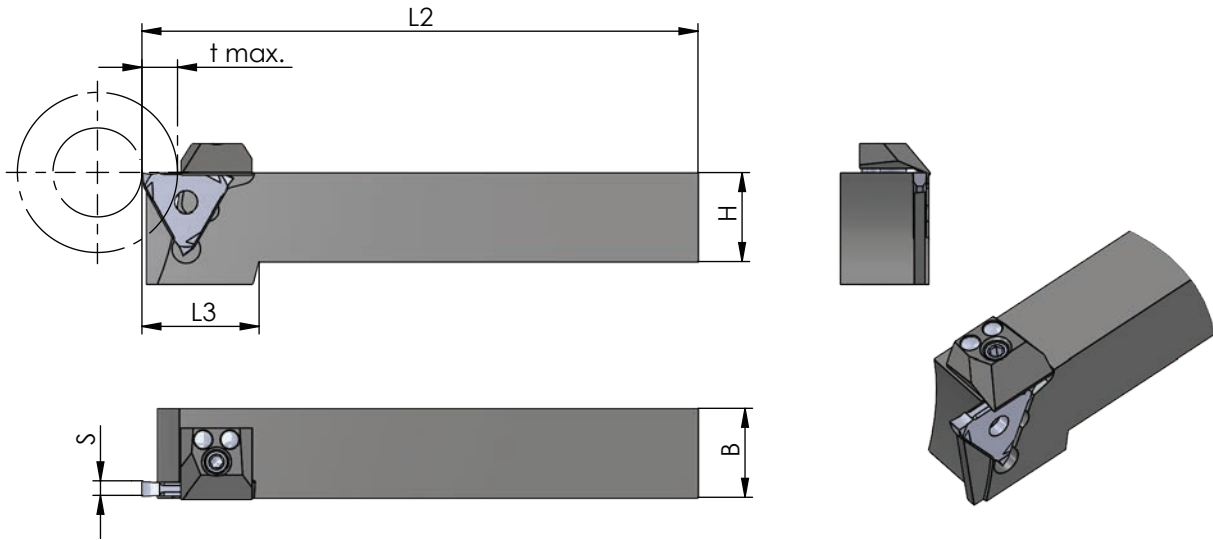

Rechts (R): wie gezeichnet  
Links (L): spiegelbildlich

righthand (R): as shown  
lefthand version (L): mirror image

Abmessungen in mm

dimensions in mm

Bestellnummer part number	H	B	*t max.	L2	L3	Spannpratze claw	Spannschraube screw	Führungsstifte guide pin	Spannbereich S holding capacity S		Wende- schneidplatte S indexable insert S
									<=		
R/L .0.780.2020.2-D	20	20	8	125	25	R.0.780. ... : PD21/R L.0.780. ... : PD21/L	ZT200	6325	1.9 - 3.0		
R/L .0.780.2525.2-D	25	25	8	150	-				2.9 - 4.0		
R/L .0.780.3232.2-D	32	32	8	170	-				3.9 - 6.5		
R/L .0.780.2020.3-D	20	20	8	125	25	R.0.780. ... : PD25/R L.0.780. ... : PD25/L	ZT200	6325	1.9 - 3.0		
R/L .0.780.2525.3-D	25	25	8	150	-				2.9 - 4.0		
R/L .0.780.3232.3-D	32	32	8	170	-				3.9 - 6.5		
R/L .0.780.2020.4-D	20	20	8	125	25	R.0.780. ... : PD25/R L.0.780. ... : PD25/L	ZT200	6325	1.9 - 3.0		
R/L .0.780.2525.4-D	25	25	8	150	-				2.9 - 4.0		
R/L .0.780.3232.4-D	32	32	8	170	-				3.9 - 6.5		

\*tmax. reduziert bei Werkstück Ø > 125  
\*tmax. reduced for workpiece Ø > 125

Bestellbeispiel:  
für rechte Ausführung  
R.0.780.2020.2-D

order-example:  
righthand version  
R.0.780.2020.2-D

## SYSTEM DED

Einstecken mit dreischneidigen Wendeplatten

grooving with three-cutting edges indexable inserts

## Typ .0.738

Klemmhalter, gekröpft, Außenbearbeitung

toolholder, cranked, external application

Stechtiefe t max. 6 mm  
Spannbereich S 0.5 - 6.5 mm

depth of groove t max. 6 mm  
holding capacity S 0.5 - 6.5 mm

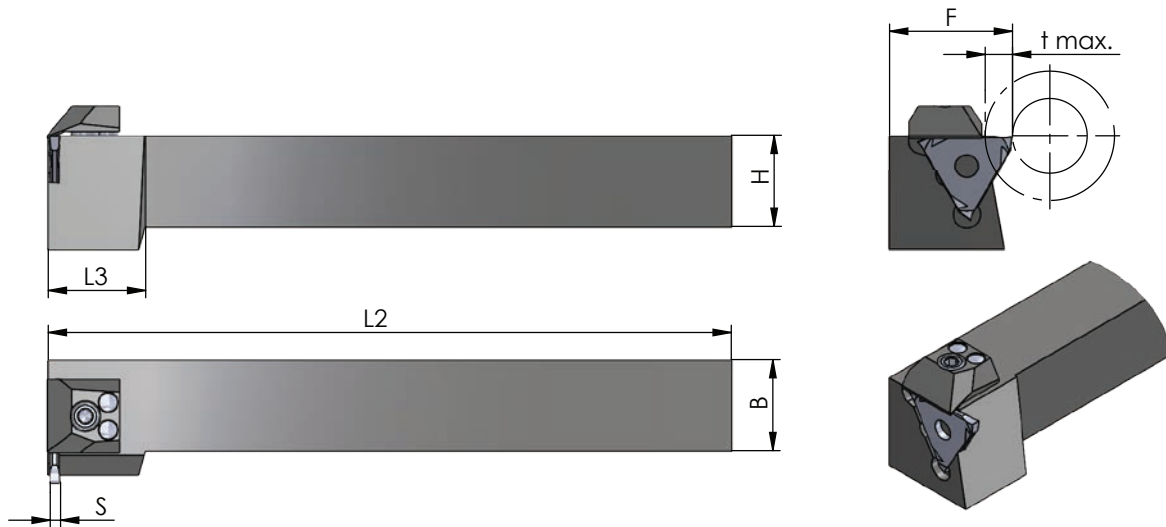

Rechts (R): wie gezeichnet  
Links (L): spiegelbildlich

righthand (R): as shown  
lefthand version (L): mirror image

Abmessungen in mm

dimensions in mm



Bestellnummer part number	H	B	F	*t max.	L2	L3	Spannpratze claw	Spannschraube screw	Führungsstifte guide pin	Spannbereich S holding capacity S		Wende- schneidplatte S indexable insert S
										<	<	
R/L .0.738.2020.1-D	20	20	27	4	150	20	PD21/L R.0.738. ... ; PD21/R L.0.738. ... ; PD21/R	ZT200	6325	0.5 - 2.0		
R/L .0.738.2525.1-D	25	25	32	4	150	-				1.9 - 3.0		
R/L .0.738.2020.2-D	20	20	27	6	150	20				2.9 - 4.0		
R/L .0.738.2525.2-D	25	25	32	6	150	-				3.9 - 6.5		
R/L .0.738.2020.3-D	20	20	27	6	150	20	PD25/L R.0.738. ... ; PD25/R L.0.738. ... ; PD25/R	ZT200	6325	0.5 - 2.0		
R/L .0.738.2525.3-D	25	25	32	6	150	-				1.9 - 3.0		
R/L .0.738.2020.4-D	20	20	27	6	150	20	PD25/L R.0.738. ... ; PD25/R L.0.738. ... ; PD25/R	ZT200	6325	2.9 - 4.0		
R/L .0.738.2525.4-D	25	25	32	6	150	-				3.9 - 6.5		

\*tmax. reduziert bei Werkstück Ø > 40  
\*tmax. reduced for workpiece Ø > 40

Bestellbeispiel:  
für rechte Ausführung  
R.0.738.2020.1-D

order-example:  
righthand version  
R.0.738.2020.1-D

## SYSTEM DED

Einstecken mit dreischneidigen Wendeplatten

grooving with three-cutting edges indexable inserts

## Typ .0.618

Klemmhalter, für Eckenfreistriche, Außenbearbeitung

toolholder, for corner reliefs, external application

Spannbereich S 1.9 - 6.5 mm

holding capacity S 1.9 - 6.5 mm

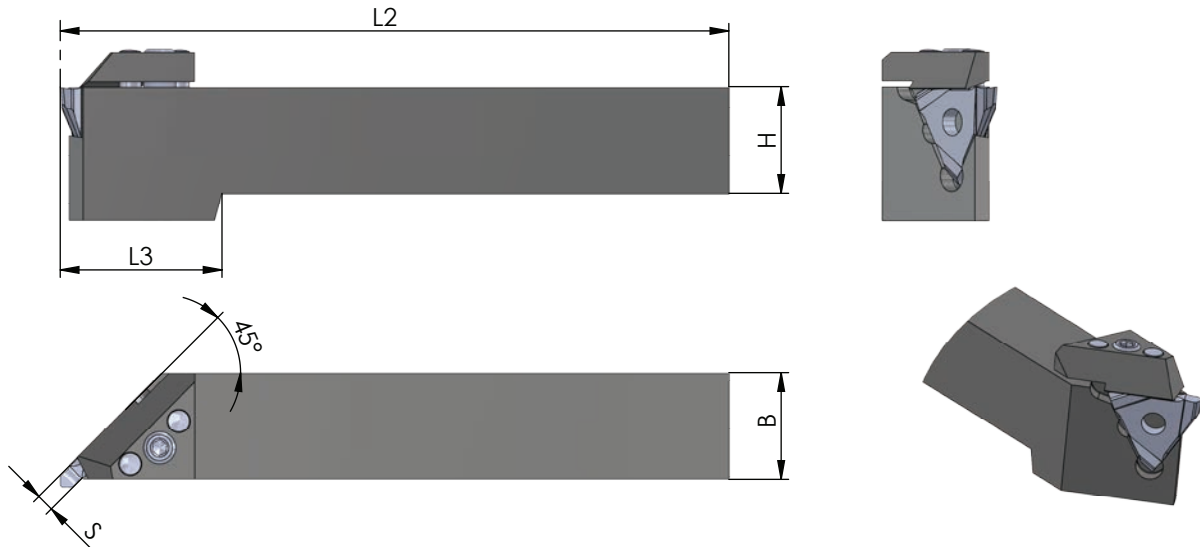

Rechts (R): wie gezeichnet  
Links (L): spiegelbildlich

righthand (R): as shown  
lefthand version (L): mirror image

Abmessungen in mm

dimensions in mm

Bestellnummer part number	H	B	L2	L3	Spannpratze claw	Spannschraube screw	Führungsstifte guide pin	Spannbereich S holding capacity S	
								<=	Wende- schneidplatte S indexable insert S
R/L .0.618.2020.2-D	20	20	125	30	R.0.618. ... : PD22/R L.0.618. ... : PD22/L	ZT200	6325	1.9 - 3.0	
R/L .0.618.2525.2-D	25	25	150	-				2.9 - 4.0	
R/L .0.618.3232.2-D	32	32	170	-				3.9 - 6.5	
R/L .0.618.2020.3-D	20	20	125	30	R.0.618. ... : PD23/R L.0.618. ... : PD23/L	ZT200	6325	1.9 - 3.0	
R/L .0.618.2525.3-D	25	25	150	-				2.9 - 4.0	
R/L .0.618.3232.3-D	32	32	170	-				3.9 - 6.5	
R/L .0.618.2020.4-D	20	20	125	30	R.0.618. ... : PD23/R L.0.618. ... : PD23/L	ZT200	6325	1.9 - 3.0	
R/L .0.618.2525.4-D	25	25	150	-				2.9 - 4.0	
R/L .0.618.3232.4-D	32	32	170	-				3.9 - 6.5	

Bestellbeispiel:  
für rechte Ausführung  
R.0.618.2020.2-D

order-example:  
righthand version  
R.0.618.2020.2-D

# SYSTEM DED

Einstecken mit dreischneidigen Wendeplatten

grooving with three-cutting edges indexable inserts

# Typ .0.660

Bohrstange, Innenbearbeitung

grooving boring bar, internal application

D min. 46  
Spannbereich S 0.5 - 6.5 mm

D min. 46  
holding capacity S 0.5 - 6.5 mm

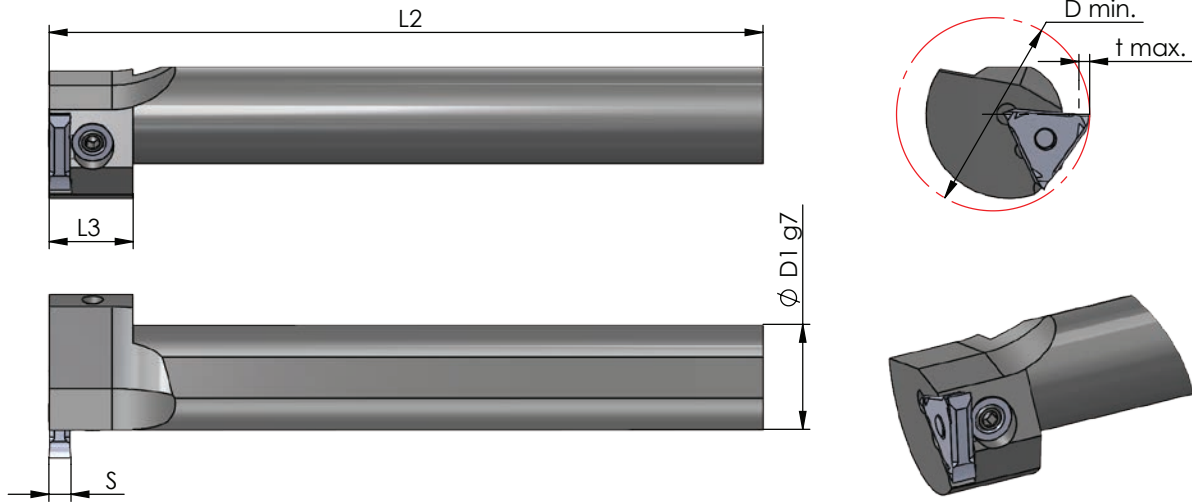

Rechts (R): wie gezeichnet  
Links (L): spiegelbildlich

righthand (R): as shown  
lefthand version (L): mirror image

Abmessungen in mm

dimensions in mm



Bestellnummer part number	Ø D1 g7	*D min.	*t max.	L2	L3	Spannpratze claw	Spannschraube screw	Spannbereich S holding capacity S	
								<=	Wende- schneidplatte S indexable insert S
R/L .0.660.0025.1-D	25	46		170	20	PD.0.660.2	ZT300	0.5 - 2.0	
R/L .0.660.0032.1-D	32	46		200	20			1.9 - 3.0	
R/L .0.660.0040.1-D	40	46		250	-			2.9 - 4.0	
R/L .0.660.0025.2-D	25	46		170	20			3.9 - 6.5	
R/L .0.660.0032.2-D	32	46		200	20				
R/L .0.660.0040.2-D	40	46		250	-				
R/L .0.660.0025.3-D	25	46		170	20				
R/L .0.660.0032.3-D	32	46		200	20				
R/L .0.660.0040.3-D	40	46		250	-				
R/L .0.660.0025.4-D	25	46		170	20				
R/L .0.660.0032.4-D	32	46		200	20				
R/L .0.660.0040.4-D	40	46		250	-				

*D min.	46	50	60	80	100
*Stechtiefe t max. / max. depth of groove	2	3	4	4.5	5

Bestellbeispiel:  
für rechte Ausführung  
R.0.660.0025.1-D



order-example:  
righthand version  
R.0.660.0025.1-D



## SYSTEM DED

Einstecken mit dreischneidigen Wendeplatten

grooving with three-cutting edges indexable inserts

## Typ .0.736

Klemmhalter, zum Abstechen, Außenbearbeitung

toolholder, for parting off, external application

Stechtiefe t max. 8 mm  
Stechbreite S 0.5 - 1.2 mm

depth of groove t max. 8 mm  
width of groove S 0.5 - 1.2 mm

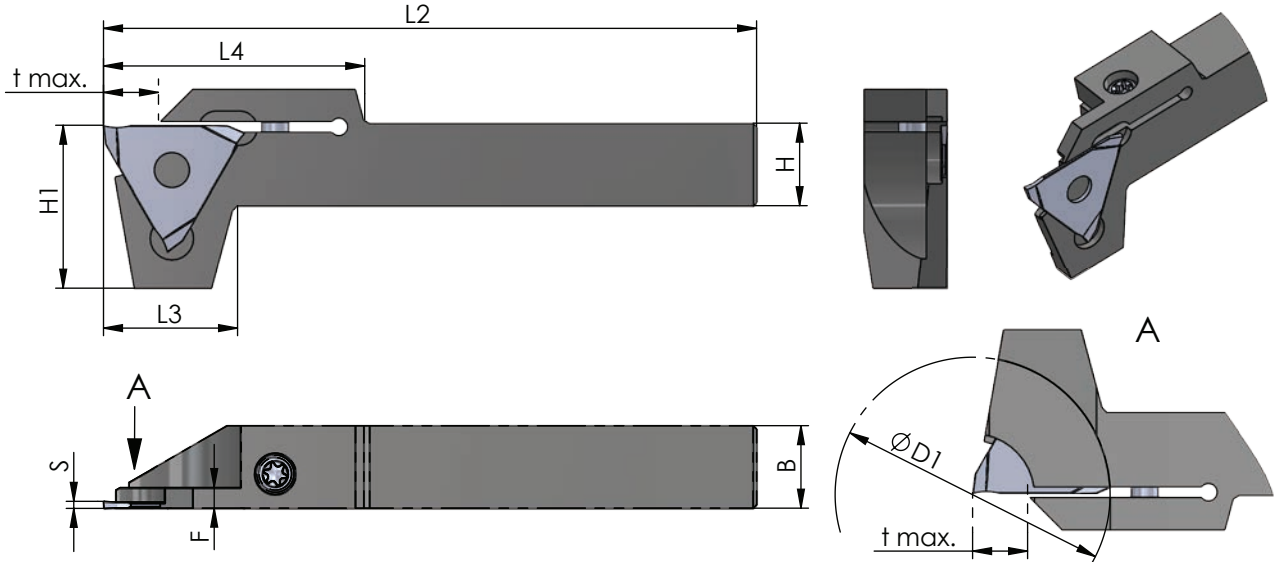

Rechts (R): wie gezeichnet  
Links (L): spiegelbildlich

righthand (R): as shown  
lefthand version (L): mirror image

Abmessungen in mm

dimensions in mm

Bestellnummer part number	H = B	H1	t max.	L2	L3	L4	F	Ø D1	Spannschraube screw	Schraubenschlüssel wrench	für Wende- schneidplatten for indexable inserts	Stechbreite S width of groove S
R/L .0.736.1212-D	12	24	8	95	19.5	38	3	40	M4-MC	TR15	R/L DED.0805.00	0.5
											R/L DED.0808.00	0.8
											R/L DED.0510.00	1.0
											R/L DED.0512.00	1.2
											R/L DED.1210.00	1.0
R/L .0.736.1616-D	16	24	8	95	19.5	38	3	40	M4-MC	TR15	R/L DED.0805.00	0.5
											R/L DED.0808.00	0.8
											R/L DED.0510.00	1.0
											R/L DED.0512.00	1.2
											R/L DED.1210.00	1.0

Bestellbeispiel:  
für rechte Ausführung  
R.0.736.1212-D

order-example:  
righthand version  
R.0.736.1212-D

## SYSTEM DED

Einstecken mit dreischneidigen Wendepplatten

grooving with three-cutting edges indexable inserts

## Typ Stechdrehen

Wendeschneidplatte, für Sicherungsringe DIN 471 / 472 und Stechdrehen allgemein

indexable insert, for circlips DIN 471 / 472 and general grooving

Stechbreite S 0.57 - 5.29 mm

width of groove S 0.57 - 5.29 mm

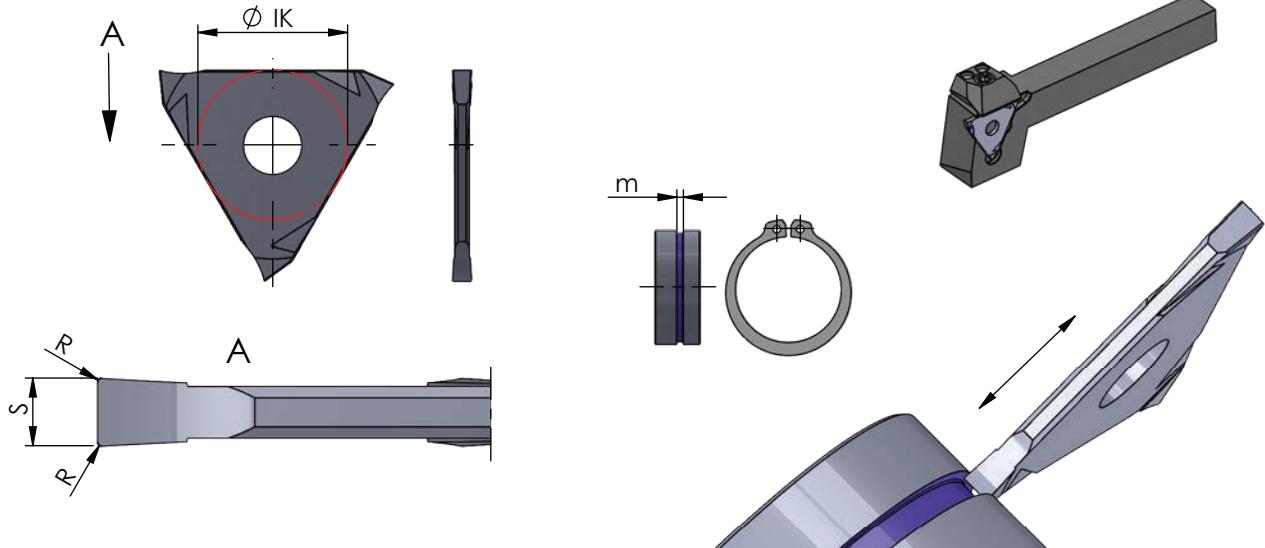

Wendeschneidplatten sind in rechten und linken Klemmhaltern sowie Bohrstängen verwendbar

inserts can be used in RH and LH toolholders as well as in boring bars

Abmessungen in mm

dimensions in mm



Bestellnummer part number	Nut-Maß m groove dim. m DIN 471 / DIN 472	S -0.05	S (inch)	R	Ø IK ± 0.06	Ø IK -0.03					Klemmhalter Typ toolholder type
							K10F	CN45F	AL41F	P07C	
DED.0050.00	0.5	0.57		0.05	13.0	●	●	●		R/L .207, .... .1-D R/L .0.738, .... .1-D R/L .0.660, .... .1-D	
DED.0060.00	0.6	0.67		0.05	13.0	●	●	●			
DED.U066.00	-	0.66	0.026"	0.05	13.0			●			
DED.0070.00	0.7	0.77		0.05	13.0	●	●	●			
DED.0080.00	0.8	0.87		0.05	13.0	●	●	●			
DED.0090.00	0.9	0.97		0.05	13.0	●	●	●			
DED.0100.00	1.0	1.07		0.1	13.0	●	●	●			
DED.0110.00	1.1	1.24		0.1	13.0	●	●	●			
DED.U117.00	-	1.17	0.046"	0.1	13.2			●			
DED.0130.00	1.3	1.44		0.1	13.2	●	●	●			
DED.U142.00	-	1.42	0.056"	0.1	13.2			●			
DED.0160.00	1.6	1.74		0.1	13.2	●	●	●			
DED.0185.00	1.85	1.99		0.1	13.2	●	●	●			
DED.U198.00	-	1.98	0.078"	0.1	13.2			●			
↳ ...											

Weitere HM Sorten können Sie in der Sortenübersicht im Kapitel "Technische Hinweise" und der Preisliste finden.

Bestellbeispiel:  
für Sorte AL41F:  
DED.0050.00/AL41F

More carbide grades you can find in the grades summary in the chapter "technical instructions" and in the price list.

order-example:  
grade AL41F:  
DED.0050.00/AL41F

**BROTECH**

## SYSTEM DED

Einstecken mit dreischneidigen Wendeplatten

grooving with three-cutting edges indexable inserts

## Typ Stechdrehen

Wendeschneidplatte, für Sicherungsringe DIN 471 / 472 und Stechdrehen allgemein

indexable insert, for circlips DIN 471 / 472 and general grooving

Stechbreite S 0.57 - 5.29 mm

width of groove S 0.57 - 5.29 mm

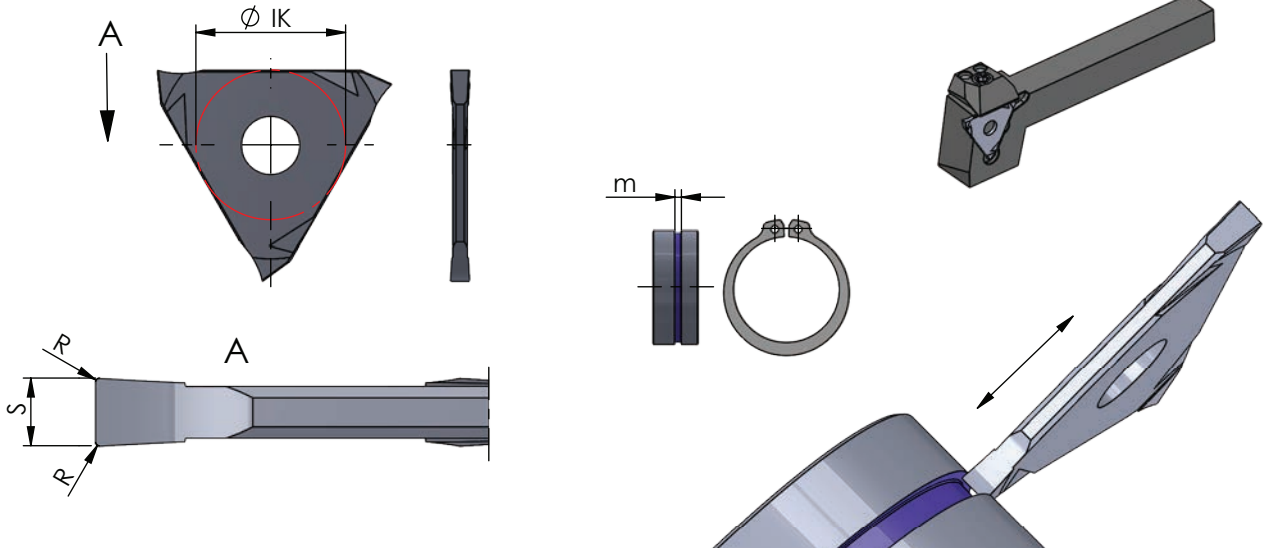

Wendeschneidplatten sind in rechten und linken Klemmhaltern sowie Bohrstäben verwendbar

inserts can be used in RH and LH toolholders as well as in boring bars

Abmessungen in mm

dimensions in mm

Bestellnummer part number	Nut-Maß m groove dim. m DIN 471 / DIN 472	S -0.05	S (inch)	R	Ø IK ± 0.06	Ø IK -0.03					Klemmhalter Typ toolholder type
							K10F	CN45F	AL41F	P07C	
DED.0215.00	2.15	2.29	0.1	13.2	●	●	●			R/L .207. .... 2-D	
DED.U223.00	-	2.23	0.088"	0.1			●			R/L .0.738. .... 2-D	
DED.U238.00	-	2.38	0.094"	0.1			●			R/L .0.780. .... 2-D	
DED.0265.00	2.65	2.79	0.1	13.2	●	●	●			R/L .0.660. .... 2-D	
DED.0315.00	3.15	3.29	0.1	13.2	●	●	●			R/L .207. .... 3-D	
DED.U398.00	-	3.98	0.157"	0.1			●			R/L .0.738. .... 3-D	
										R/L .0.780. .... 3-D	
										R/L .0.660. .... 3-D	
DED.0415.00	4.15	4.29	0.1	13.2	●	●	●			R/L .207. .... 4-D	
DED.0515.00	5.15	5.29	0.1	13.2	●	●	●			R/L .0.738. .... 4-D	
										R/L .0.780. .... 4-D	
										R/L .0.660. .... 4-D	

Weitere HM Sorten können Sie in der Sortenübersicht im Kapitel "Technische Hinweise" und der Preisliste finden.

More carbide grades you can find in the grades summary in the chapter "technical instructions" and in the price list.

Bestellbeispiel:  
für Sorte AL41F:  
DED.0215.00/AL41F

order-example:  
grade AL41F:  
DED.0215.00/AL41F



## SYSTEM DED

Einstecken mit dreischneidigen Wendeplatten

grooving with three-cutting edges indexable inserts

## Typ Stechdrehen

Wendeschneidplatte, für unterbrochene Schnitte und Sicherungsringe DIN 471 / 472

indexable insert, for interrupted cuts and circlips DIN 471 / 472

Stechbreite S 1.07 - 5.29 mm

width of groove S 1.07 - 5.29 mm

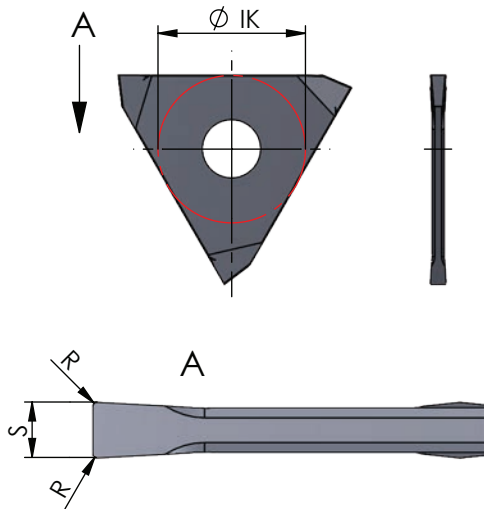

Wendeschneidplatten sind in rechten und linken Klemmhaltern sowie Bohrstängen verwendbar

inserts can be used in RH and LH toolholders as well as in boring bars

Abmessungen in mm

dimensions in mm



Bestellnummer part number	Nut-Maß m groove dim. m DIN 471 / DIN 472	S -0.05	R	Ø IK -0.03					Klemmhalter Typ toolholder type
					K10F	CN45F	AL41F	P07C	
DED.0100.NG-D	1.0	1.07	0.1	13.0	●	●	●		R/L .207, ..... 1-D R/L .0.738, ..... 1-D R/L .0.660, ..... 1-D
DED.0110.NG-D	1.1	1.24	0.1	13.0	●	●	●		
DED.0130.NG-D	1.3	1.44	0.1	13.0	●	●	●		
DED.0160.NG-D	1.6	1.74	0.1	13.0	●	●	●		
DED.0185.NG-D	1.85	1.99	0.1	13.0	●	●	●		
DED.0215.NG-D	2.15	2.29	0.1	13.0	●	●	●		R/L .207, ..... 2-D R/L .0.738, ..... 2-D R/L .0.780, ..... 2-D R/L .0.660, ..... 2-D
DED.0265.NG-D	2.65	2.79	0.1	13.0	●	●	●		
DED.0315.NG-D	3.15	3.29	0.1	13.0	●	●	●		
DED.0415.NG-D	4.15	4.29	0.1	13.0	●	●	●		R/L .207, ..... 4-D R/L .0.738, ..... 4-D R/L .0.780, ..... 4-D R/L .0.660, ..... 4-D
DED.0515.NG-D	5.15	5.29	0.1	13.0	●	●	●		

Weitere HM Sorten können Sie in der Sortenübersicht im Kapitel "Technische Hinweise" und der Preisliste finden.

Bestellbeispiel:  
für Sorte AL41F:  
DED.0100.NG-D/AL41F

More carbide grades you can find in the grades summary in the chapter "technical instructions" and in the price list.

order-example:  
grade AL41F:  
DED.0100.NG-D/AL41F

**BROTECH**

## SYSTEM DED

Einstecken mit dreischneidigen Wendeplatten

grooving with three-cutting edges indexable inserts

## Typ Stechdrehen

Wendeschneidplatte, für Sicherungsringe DIN 471 / 472, stabile Ausführung

indexable insert, for circlips DIN 471 / 472, solid construction

Stechbreite C 0.55 - 1.05 mm

width of groove C 0.55 - 1.05 mm

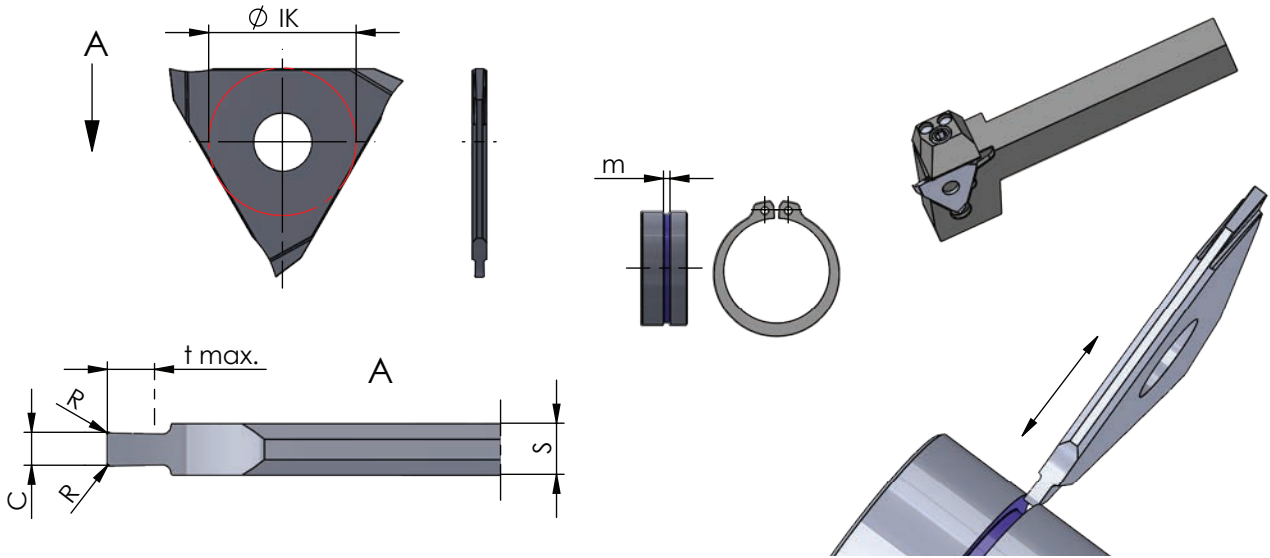

Wendeschneidplatten sind in rechten und linken Klemmhaltern sowie Bohrstängen verwendbar

inserts can be used in RH and LH toolholders as well as in boring bars

Abmessungen in mm

dimensions in mm

Bestellnummer part number	Nut-Maß m groove dim. m DIN 471 / DIN 472	C -0.03	S ±0.02	t max.	R	Ø IK -0.03	K10F	CN45F	AL41F	P07C	Klemmhalter Typ toolholder type
DED.0050.13	0.5	0.55	1.3	0.7	0.05	13.0	●	●			R/L .207, ..... 1-D R/L .0.738, ..... 1-D R/L .0.660, ..... 1-D
DED.0060.13	0.6	0.65	1.3	0.8	0.05	13.0	●	●			
DED.0070.13	0.7	0.75	1.3	1.1	0.05	13.0	●	●			
DED.0080.13	0.8	0.85	1.3	1.2	0.05	13.0	●	●			
DED.0090.13	0.9	0.95	1.3	1.4	0.05	13.0	●	●			
DED.0100.13	1.0	1.05	1.3	1.6	0.1	13.0	●	●			

Weitere HM Sorten können Sie in der Sortenübersicht im Kapitel "Technische Hinweise" und der Preisliste finden.

Bestellbeispiel:  
für Sorte AL41F:  
DED.0050.13/AL41F

More carbide grades you can find in the grades summary in the chapter "technical instructions" and in the price list.

order-example:  
grade AL41F:  
DED.0050.13/AL41F

**BROTECH**

## SYSTEM DED

Einstecken mit dreischneidigen Wendeplatten

grooving with three-cutting edges indexable inserts

## Typ Stechdrehen

Wendeschneidplatte, für Sicherungsringe DIN 471 / 472 mit Nutaußenkantenfasung

indexable insert, for circlips DIN 471 / 472 with chamfer

Stechbreite C 1.24 - 5.29 mm

width of groove C 1.24 - 5.29 mm

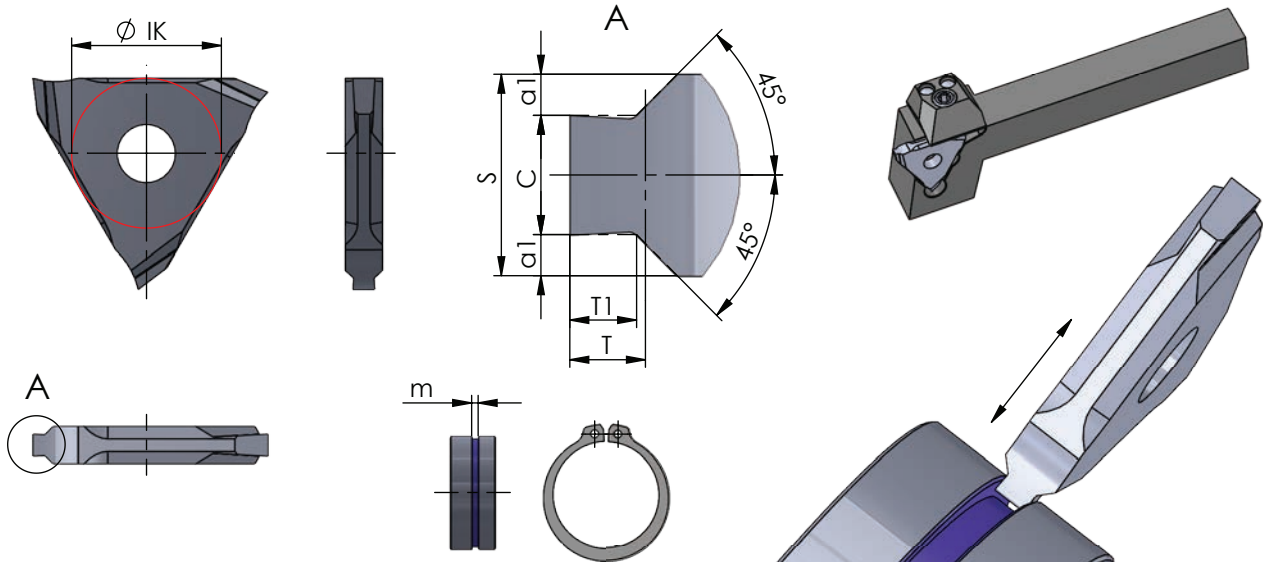

Wendeschneidplatten sind in rechten und linken Klemmhaltern sowie Bohrstängen verwendbar

inserts can be used in RH and LH toolholders as well as in boring bars

Abmessungen in mm

dimensions in mm



Bestellnummer part number	Nut-Maß m groove dim. m DIN 471 / DIN 472	C -0.05	S	a	T1 -0.05	T	$\varnothing IK \pm 0.06$	K10F CN45F AL41F P07C	Klemmhalter Typ toolholder type
DED.1101.25	1.1	☺	1.24	2.5	0.64	0.19	0.20	● ● ●	R/L .207, .... .2-D R/L .0.738, .... .2-D R/L .0.780, .... .2-D R/L .0.660, .... .2-D
DED.1102.25	1.1	☺	1.24	2.5	0.64	0.24	0.25	● ● ●	
DED.1103.25	1.1	☺	1.24	2.5	0.64	0.29	0.30	● ● ●	
DED.1104.25	1.1	☺	1.24	2.5	0.64	0.33	0.35	● ● ●	
DED.1105.25	1.1	☺	1.24	2.5	0.64	0.36	0.40	● ● ●	
DED.1306.25	1.3	☺	1.44	2.5	0.54	0.45	0.55	● ● ●	
DED.1607.33	1.6	☺	1.74	3.3	0.79	0.60	0.70	● ● ●	R/L .207, .... .3-D R/L .0.738, .... .3-D R/L .0.780, .... .3-D R/L .0.660, .... .3-D
DED.1608.33	1.6	☺	1.74	3.3	0.79	0.75	0.85	● ● ●	
DED.1609.33	1.6	☺	1.74	3.3	0.79	0.85	1.00	● ● ●	
DED.1810.33	1.85	☺	1.99	3.3	0.67	0.85	1.00	● ● ●	
DED.1812.33	1.85	☺	1.99	3.3	0.67	1.10	1.25	● ● ●	
↳ ...									

Weitere HM Sorten können Sie in der Sortenübersicht im Kapitel "Technische Hinweise" und der Preisliste finden.

Bestellbeispiel:  
für Sorte AL41F:  
DED.1101.25/AL41F

More carbide grades you can find in the grades summary in the chapter "technical instructions" and in the price list.

order-example:  
grade AL41F:  
DED.1101.25/AL41F

**BROTECH**

## SYSTEM DED

Einstecken mit dreischneidigen Wendepplatten

grooving with three-cutting edges indexable inserts

## Typ Stechdrehen

Wendeschneidplatte, für Sicherungsringe DIN 471 / 472 mit Nutaußenkantenfasung

indexable insert, for circlips DIN 471 / 472 with chamfer

Stechbreite C 1.24 - 5.29 mm

width of groove C 1.24 - 5.29 mm

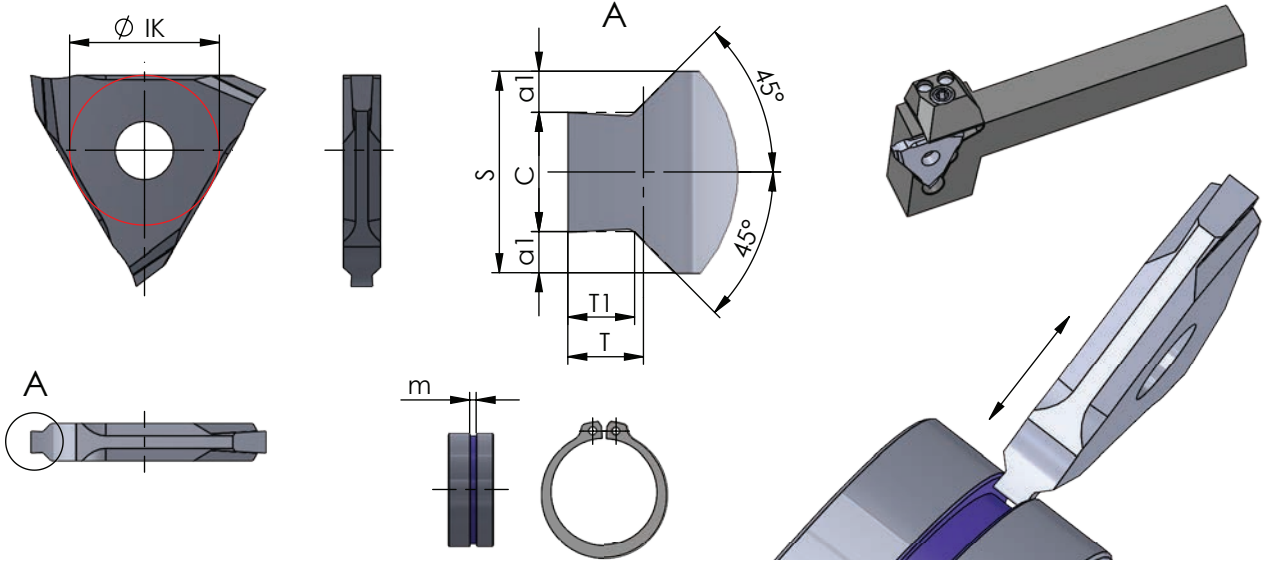

Wendeschneidplatten sind in rechten und linken Klemmhaltern sowie Bohrstängen verwendbar

inserts can be used in RH and LH toolholders as well as in boring bars

Abmessungen in mm

dimensions in mm

Bestellnummer part number	Nut-Maß m groove dim. m DIN 471 / DIN 472	C -0.05	S	a	T1 -0.05	T	Ø IK ± 0.06					Klemmhalter Typ toolholder type
								K10F	CN45F	AL41F	P07C	
DED.2115.43	2.15	2.29	4.3	1.02	1.35	1.50	13.2	●	●	●		R/L .207. .... 4-D R/L .0.738. .... 4-D R/L .0.780. .... 4-D R/L .0.660. .... 4-D
DED.2616.43	2.65	2.79	4.3	0.77	1.35	1.50	13.2	●	●	●		
DED.2617.43	2.65	2.79	4.3	0.77	1.60	1.75	13.2	●	●	●		
DED.3118.53	3.15	3.29	5.3	1.02	1.60	1.75	13.2	●	●	●		
DED.4120.53	4.15	4.29	5.3	0.52	1.85	2.00	13.2	●	●	●		
DED.4125.53	4.15	4.29	5.3	0.52	2.35	2.50	13.2	●	●	●		
DED.5130.63	5.15	5.29	6.3	0.52	2.85	3.00	13.2	●	●	●		

Weitere HM Sorten können Sie in der Sortenübersicht im Kapitel "Technische Hinweise" und der Preisliste finden.

Bestellbeispiel:  
für Sorte AL41F:  
DED.2115.43/AL41F

More carbide grades you can find in the grades summary in the chapter "technical instructions" and in the price list.

order-example:  
grade AL41F:  
DED.2115.43/AL41F

**BROTECH**

## SYSTEM DED

Einstecken mit dreischneidigen Wendepplatten

grooving with three-cutting edges indexable inserts

## Typ Stechdrehen

Wendeschneidplatte, zum Feindrehen

indexable insert, for finishing

Stechbreite S 1.0 - 4.0 mm

width of groove S 1.0 - 4.0 mm

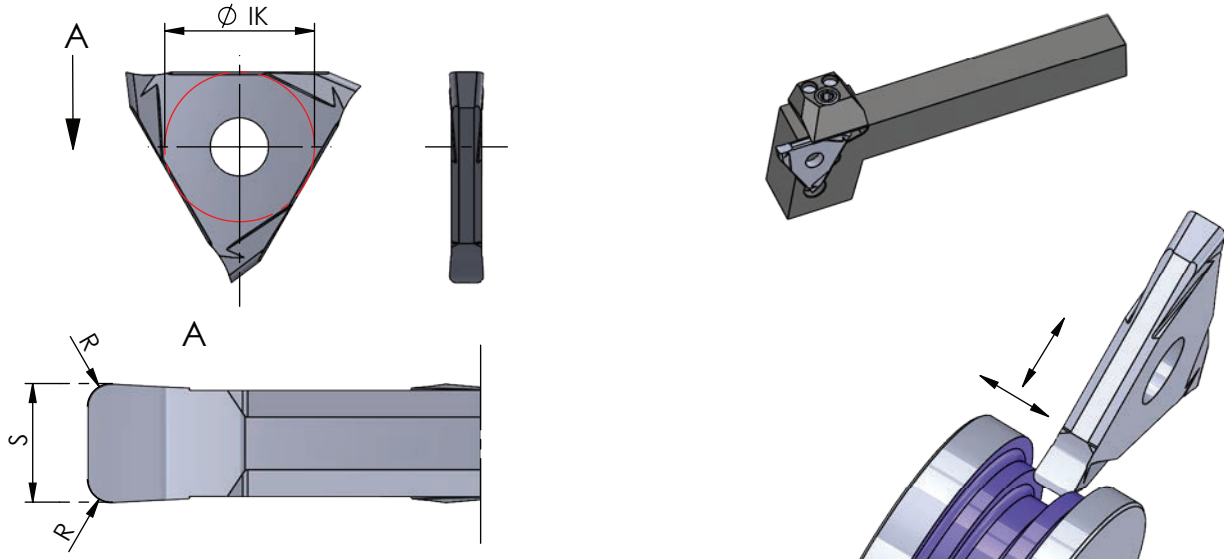

Wendeschneidplatten sind in rechten und linken Klemmhaltern sowie Bohrstängen verwendbar

inserts can be used in RH and LH toolholders as well as in boring bars

Abmessungen in mm

dimensions in mm



Bestellnummer part number								Klemmhalter Typ toolholder type
	S +0.03	R	Ø IK ± 0.06	K10F	CN45F	AL41F	P07C	
DED.0100.02	1.0	0.2	13.2	●		●		R/L .207. .... .1-D R/L .0.738. .... .1-D (R/L .0.660. .... .1-D)
DED.0150.02	1.5	0.2	13.2	●	●	●		
DED.0200.02	2.0	0.2	13.2	●	●	●		
DED.0200.04	2.0	0.4	13.2	●	●	●		
DED.0300.02	3.0	0.2	13.2	●	●	●		R/L .207. .... .2-D R/L .0.738. .... .2-D (R/L .0.780. .... .2-D) (R/L .0.660. .... .2-D)
DED.0300.06	3.0	0.6	13.2	●	●	●		
DED.0300.08	3.0	0.8	13.2	●	●	●		
DED.0400.02	4.0	0.2	13.2	●	●	●		
DED.0400.08	4.0	0.8	13.2	●	●	●		R/L .207. .... .3-D R/L .0.738. .... .3-D (R/L .0.780. .... .3-D) (R/L .0.660. .... .3-D)
DED.0400.12	4.0	1.2	13.2	●	●	●		

Weitere HM Sorten können Sie in der Sortenübersicht im Kapitel "Technische Hinweise" und der Preisliste finden.

Bestellbeispiel:  
für Sorte AL41F:  
DED.0100.02/AL41F

More carbide grades you can find in the grades summary in the chapter "technical instructions" and in the price list.

order-example:  
grade AL41F:  
DED.0100.02/AL41F

**BROTECH**



## SYSTEM DED

Einstecken mit dreischneidigen Wendeplatten

grooving with three-cutting edges indexable inserts

## Typ Stechdrehen

Wendeschneidplatte, Vollradius, für Nuten und Eckenfreistich

indexable insert, full radius, for grooving and corner reliefs

Stechbreite S 0.5 - 5.0 mm

width of groove S 0.5 - 5.0 mm

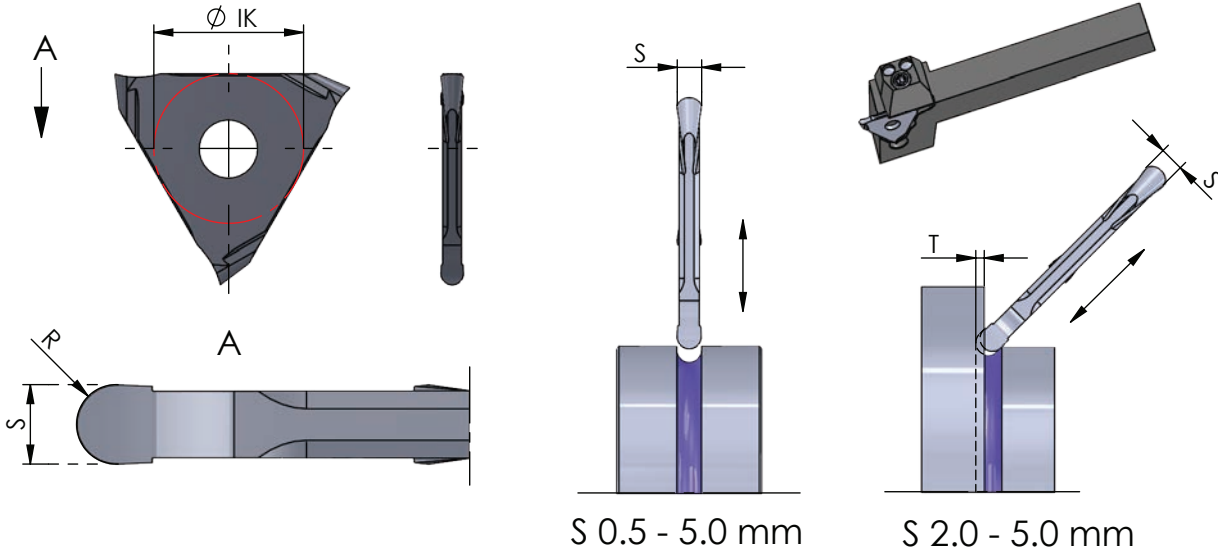

Wendeschneidplatten sind in rechten und linken Klemmhaltern sowie Bohrstängen verwendbar

inserts can be used in RH and LH toolholders as well as in boring bars

Abmessungen in mm

dimensions in mm

Bestellnummer part number	Abmessungen in mm				Ø IK ± 0.06	Material				Klemmhalter Typ toolholder type
	S ±0.05	S ±0.02	R	T		K10F	CN45F	AL41F	P07C	
DED.0002.05		0.5	0.25		13.2	●	●	●		R/L .207. .... 1-D R/L .0.738. .... 1-D R/L .0.660. .... 1-D
DED.0005.10		1.0	0.50		13.2	●	●	●		
DED.0006.12		1.2	0.60		13.2	●	●	●		
DED.0008.16		1.6	0.80		13.2	●	●	●		
DED.0010.20	2.0		1.00	0.70	13.2	●	●	●		R/L .207. .... 2-D R/L .0.738. .... 2-D R/L .0.780. .... 2-D R/L .0.660. .... 2-D R/L .0.618. .... 2-D
DED.0012.25	2.5		1.25	0.85	13.2	●	●	●		
DED.0015.30	3.0		1.50	1.00	13.2	●	●	●		
DED.0020.40	4.0		2.00	1.20	13.2	●	●	●		
DED.0025.50	5.0		2.50	1.50	13.2	●	●	●		R/L .207. .... 4-D R/L .0.738. .... 4-D R/L .0.780. .... 4-D R/L .0.660. .... 4-D R/L .0.618. .... 4-D

Weitere HM Sorten können Sie in der Sortenübersicht im Kapitel "Technische Hinweise" und der Preisliste finden.

More carbide grades you can find in the grades summary in the chapter "technical instructions" and in the price list.

Bestellbeispiel:  
für Sorte AL41F:  
DED.0002.05/AL41F

order-example:  
grade AL41F:  
DED.0002.05/AL41F



## SYSTEM DED

Einstecken mit dreischneidigen Wendeplatten

grooving with three-cutting edges indexable inserts

## Typ Stechdrehen

Wendeschneidplatte, mit Spanformer, zum Abstechen

indexable insert, with chipformer, for parting off

Stechbreite S 1.99 - 2.79 mm

width of groove S 1.99 - 2.79 mm

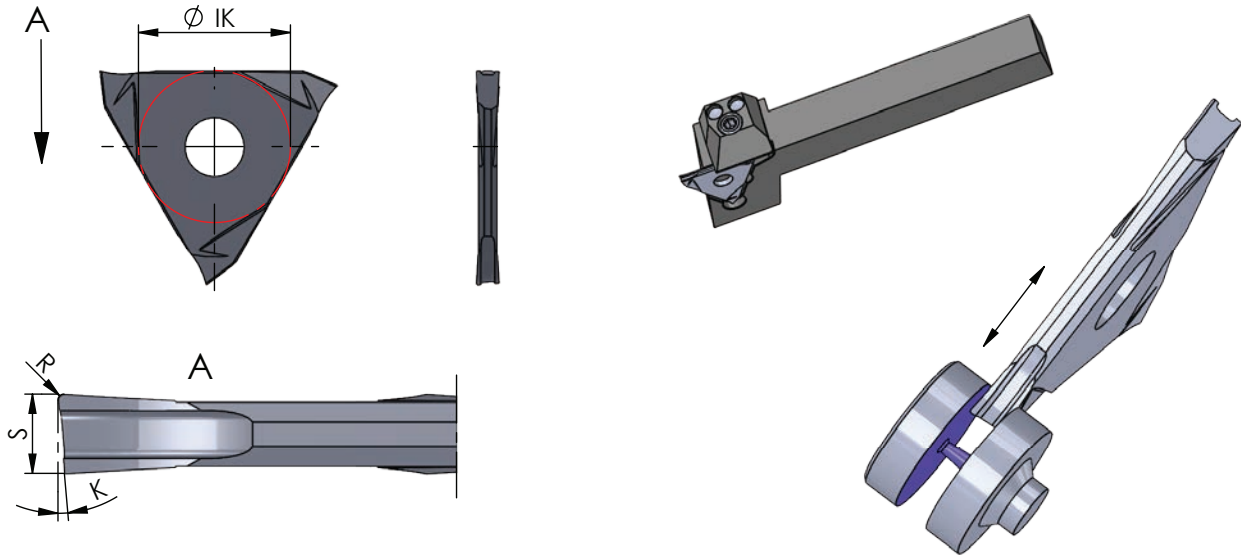

Rechts (R): wie gezeichnet  
Links (L): spiegelbildlich

Wendeschneidplatten sind in rechten und linken Klemmhaltern verwendbar.  
Abmessungen in mm

righthand version (R): as shown  
lefthand version (L): mirror image

inserts can be used in RH and LH toolholders

dimensions in mm



Bestellnummer part number	S -0.05	K	R	Ø IK ± 0.06	Klemmhalter Typ toolholder type			
					K10F	CN45F	AL41F	P07C
R/L .DED.0518.00	1.99	5°	0.15	13.2	●	●	●	R/L .207. .... .1-D R/L .0.738. .... .1-D
R/L .DED.0521.00	2.29	5°	0.15	13.2	●	●	●	R/L .207. .... .2-D
R/L .DED.0526.00	2.79	5°	0.15	13.2	●	●	●	R/L .0.738. .... .2-D R/L .0.780. .... .2-D

Weitere HM Sorten können Sie in der Sortenübersicht im Kapitel "Technische Hinweise" und der Preisliste finden.

Bestellbeispiel:  
für rechte Ausführung und Sorte:  
R.DED.0518.00/AL41F

More carbide grades you can find in the grades summary in the chapter "technical instructions" and in the price list.

order-example:  
righthand version and grade:  
R.DED.0518.00/AL41F

## SYSTEM DED

Einstecken mit dreischneidigen Wendeplatten

grooving with three-cutting edges indexable inserts

## Typ Stechdrehen

Wendeschneidplatte, ohne Spanformer, zum Abstechen

indexable insert, without chipformer, for parting off

Stechbreite S 0.5 - 1.4 mm

width of groove S 0.5 - 1.4 mm

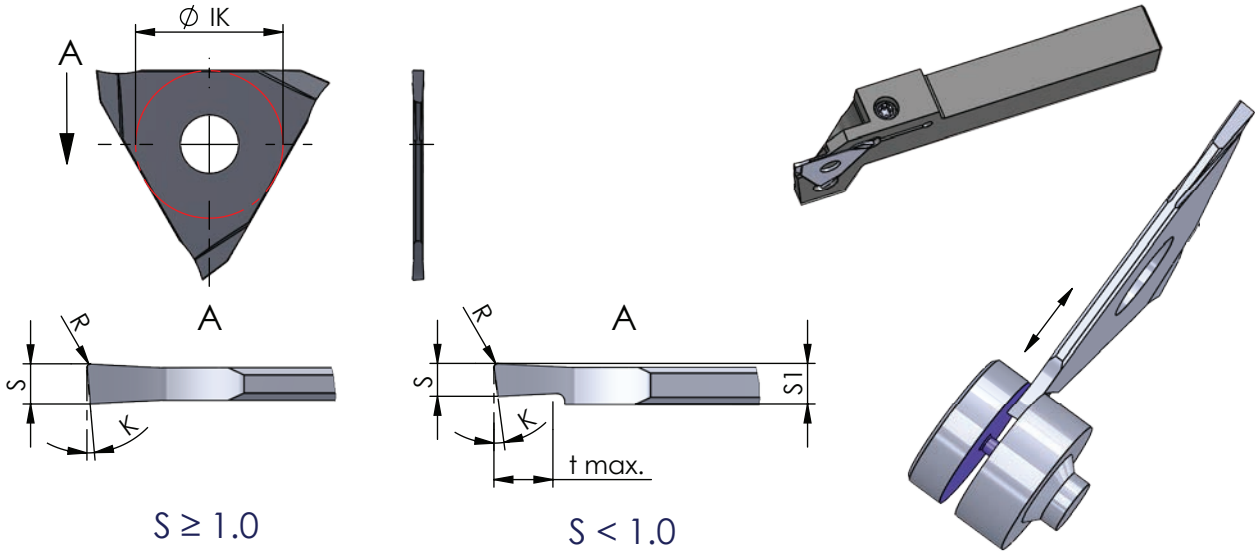

Rechts (R): wie gezeichnet  
Links (L): spiegelbildlich

Wendeschneidplatten sind in rechten und linken Klemmhaltern verwendbar.  
Abmessungen in mm

righthand version (R): as shown  
lefthand version (L): mirror image

inserts can be used in RH and LH toolholders

dimensions in mm

Bestellnummer part number	S1 -0.05	S +0.05	K	R	t max.	Ø IK ± 0.06	Ø IK -0.03	K10F CN45F AL41F P07C	Klemmhalter Typ	toolholder type
R/L .DED.0805.00	1.0	0.5	8°	0.1	1.0			● ●	R/L .207. .... .1-D R/L .0.736. ....	
R/L .DED.0808.00	1.0	0.8	8°	0.1	1.5			● ●		
R/L .DED.0510.00		1.0	5°	0.1				● ●		
R/L .DED.0512.00		1.2	5°	0.1				● ●		
R/L .DED.1210.00		1.0	12°	0.1				● ●		
R/L .DED.0614.00		1.4	6°	0.1		13.2		● ●	R/L .207. .... .1-D	

Weitere HM Sorten können Sie in der Sortenübersicht im Kapitel "Technische Hinweise" und der Preisliste finden.

Bestellbeispiel:  
für rechte Ausführung und Sorte:  
R.DED.0805.00/AL41F

More carbide grades you can find in the grades summary in the chapter "technical instructions" and in the price list.

order-example:  
righthand version and grade:  
R.DED.0805.00/AL41F

**BROTECH**

## SYSTEM DED

Einstecken mit dreischneidigen Wendeplatten

grooving with three-cutting edges indexable inserts

## Typ Stechdrehen

Wendeschneidplatte, zum Einstechen und Längsdrehen

indexable insert, for grooving and turning

Stechtiefe t max. 3.5  
Stechbreite C 3.29 mm

depth of groove t max. 3.5  
width of groove C 3.29 mm

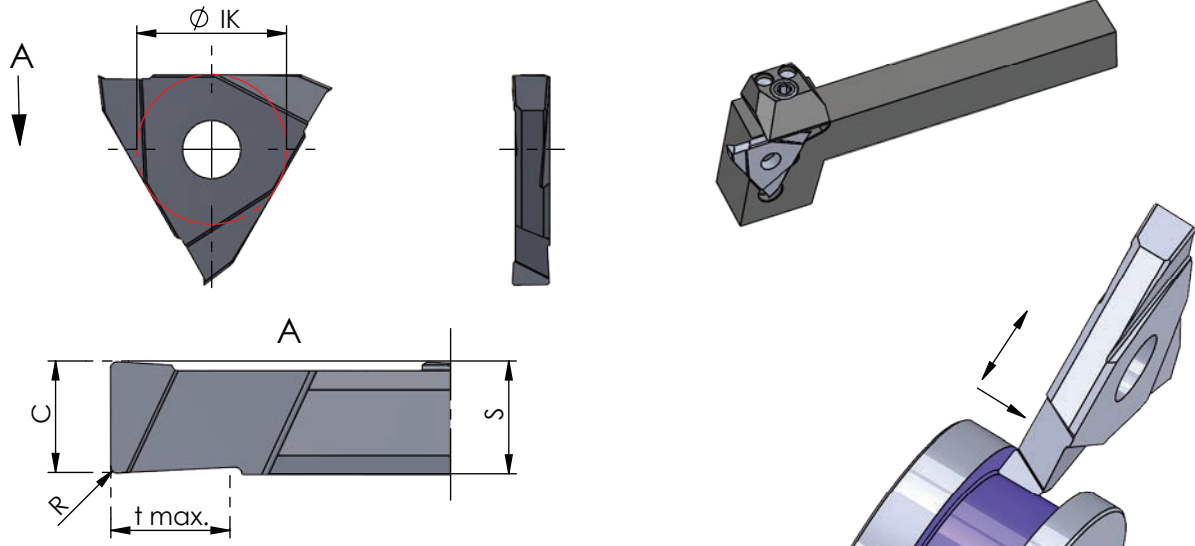

Rechts (R): wie gezeichnet  
Links (L): spiegelbildlich

Rechte Schneidpl. in rechtem Halter  
Linke Schneidpl. in linkem Halter

Abmessungen in mm

righthand version (R): as shown  
lefthand version (L): mirror image

use RH insert in RH tool holder and  
LH insert in LH tool holder

dimensions in mm



Bestellnummer part number	C -0.05	S +0.05	R	t max.	Ø IK ± 0.06	Klemmhalter Typ toolholder type				
						K10F	CN45F	AL41F	P07C	
R/L .DED.3031.33	3.29	3.3	0.2	3.5	13.2	●	●	●		R/L .207. .... .2-D R/L .0.738. .... .2-D

Weitere HM Sorten können Sie in der Sortenübersicht im Kapitel "Technische Hinweise" und der Preisliste finden.

Bestellbeispiel:  
für rechte Ausführung und Sorte:  
R.DED.3031.33/AL41F

More carbide grades you can find in the grades summary in the chapter "technical instructions" and in the price list.

order-example:  
righthand version and grade:  
R.DED.3031.33/AL41F

**BROTECH**

## SYSTEM DED

Einstecken mit dreischneidigen Wendeplatten

grooving with three-cutting edges indexable inserts

## Typ Stechdrehen

Wendeschneidplatte, für Eckenfreistich, ähnlich DIN 509 Form F

indexable insert, for corner reliefs, similar to DIN 509 type F

Stechbreite S 2.4 - 5.0 mm

width of groove S 2.4 - 5.0 mm

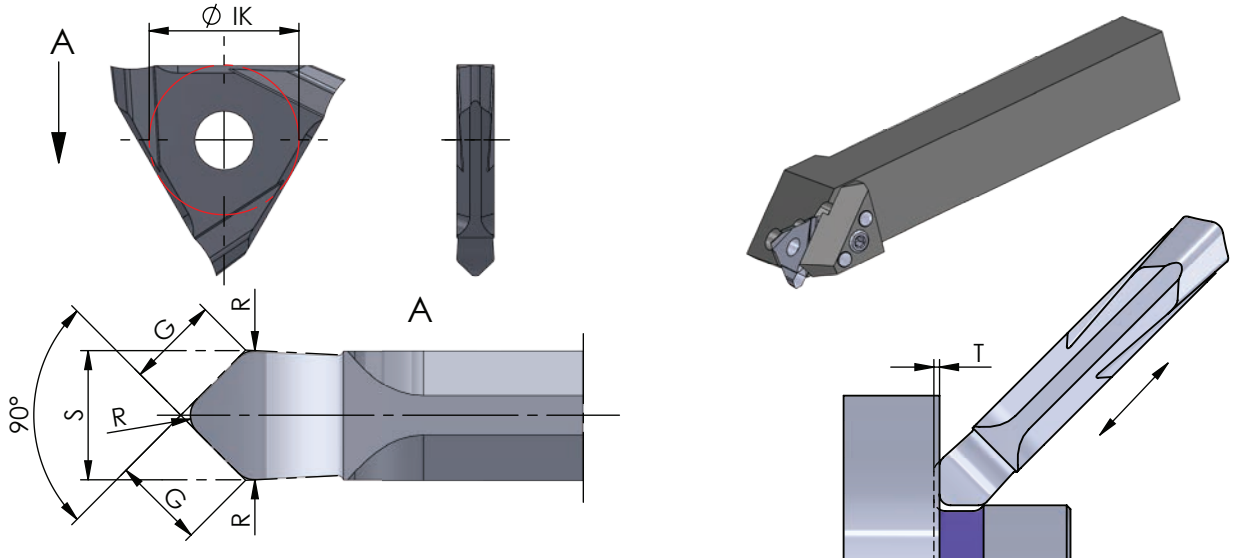

Wendeschneidplatten sind in rechten und linken Klemmhaltern verwendbar

inserts can be used in RH and LH toolholders

Abmessungen in mm

dimensions in mm

Bestellnummer part number	S -0.05	G	R	T	Ø IK ± 0.06	Klemmhalter Typ toolholder type			
						K10F	CN45F	AL41F	P07C
DED.0602.24	2.4	1.7	0.6	0.2	13.2	●	●	●	R/L .0.618. .... .2-D
DED.0603.33	3.3	2.3	0.6	0.3	13.2	●	●	●	R/L .0.618. .... .3-D
DED.1002.30	3.0	2.1	1.0	0.2	13.2	●	●	●	R/L .0.618. .... .3-D
DED.1004.50	5.0	3.6	1.0	0.4	13.2	●	●	●	R/L .0.618. .... .4-D
DED.1603.50	5.0	3.6	1.6	0.3	13.2	●	●	●	R/L .0.618. .... .4-D

Weitere HM Sorten können Sie in der Sortenübersicht im Kapitel "Technische Hinweise" und der Preisliste finden.

More carbide grades you can find in the grades summary in the chapter "technical instructions" and in the price list.

Bestellbeispiel:  
für Sorte AL41F:  
DED.0602.24/AL41F

order-example:  
grade AL41F:  
DED.0602.24/AL41F

**BROTECH**

## SYSTEM DED

Einstecken mit dreischneidigen Wendeplatten

grooving with three-cutting edges indexable inserts

## Typ Stechdrehen

Wendeschneidplatte, Axialbearbeitung

indexable insert, face grooving

D min. 20 mm  
Stechtiefe t max. 3.5  
Stechbreite C 1.5 - 5.0 mm

D min. 20 mm  
depth of groove t max. 3.5  
width of groove C 1.5 - 5.0 mm

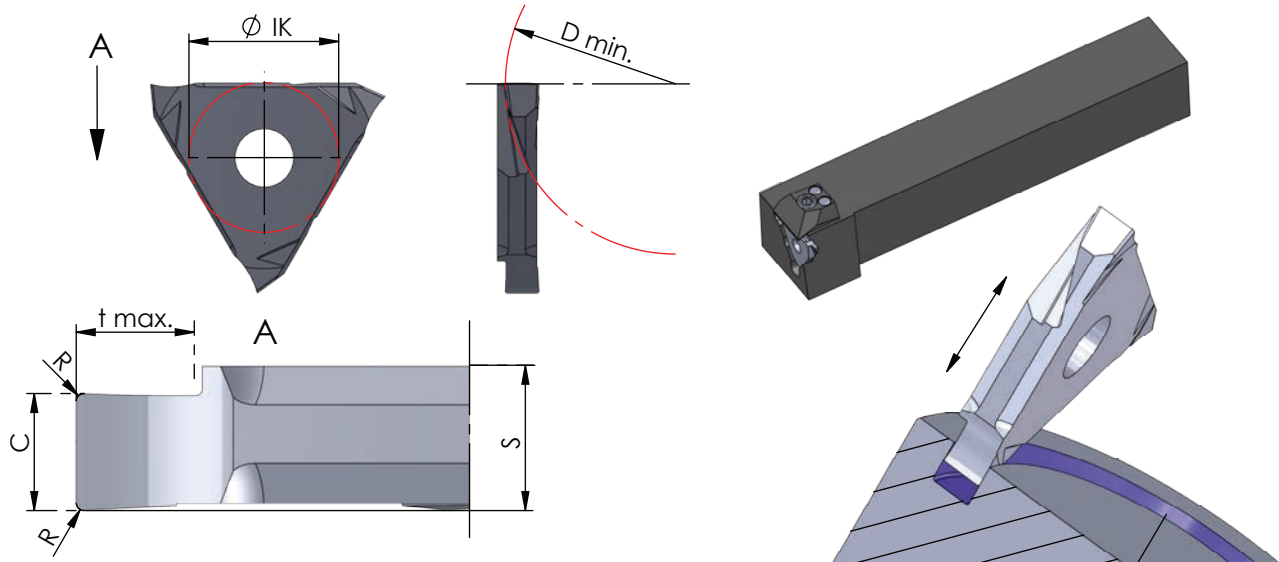

Links (L): wie gezeichnet  
Rechts (R): spiegelbildlich

Wendeschneidplatten sind in rechten und linken Klemmhaltern verwendbar  
Abmessungen in mm

lefthand version (L): as shown  
righthand version (R): mirror image

inserts can be used in RH and LH toolholders

dimensions in mm



Bestellnummer part number	C ±0.02	S	R	t max.	D min.	Ø IK ± 0.06					Klemmhalter Typ toolholder type
							K10F	CN45F	AL41F	P07C	
R/L .DED.2015.2	1.5	2.7	0.2	2.0	20	13.2	●	●	●		(R/L .207. .... .2-D)
R/L .DED.3020.2	2.0	2.7	0.2	3.0	30	13.2	●	●	●		R/L .0.738. .... .2-D
R/L .DED.3030.2	3.0	3.7	0.2	3.0	30	13.2	●	●	●		(R/L .207. .... .3-D) R/L .0.738. .... .3-D
R/L .DED.3040.2	4.0	4.3	0.2	3.5	30	13.2	●	●	●		(R/L .207. .... .4-D)
R/L .DED.3050.2	5.0	5.3	0.2	3.5	30	13.2	●	●	●		R/L .0.738. .... .4-D

Weitere HM Sorten können Sie in der Sortenübersicht im Kapitel "Technische Hinweise" und der Preisliste finden.

Bestellbeispiel:  
für rechte Ausführung und Sorte:  
R.DED.2015.2/AL41F

More carbide grades you can find in the grades summary in the chapter "technical instructions" and in the price list.

order-example:  
righthand version and grade:  
R.DED.2015.2/AL41F

## SYSTEM DED

Einstecken mit dreischneidigen Wendeplatten

grooving with three-cutting edges indexable inserts

## Sets

Bestellnummer  
part number

Inhalt  
Content

K10F  
CN45F  
AL41F  
P07C

### SET-DED 1



- Halter (rechte Ausführung)
- für Sicherungsringe DIN 471 / 472
- und Stechdrehen allgemein  
Stechbreite S 0.57 - 1.99

- toolholder (right version)
- for circlips  
DIN 471 / 472
- and general grooving  
width of groove S 0.57 - 1.99

#### Halter / toolholder:

1 x R.207.2020.1

#### Schneideinsatz / insert:

1 x DED.0050.00  
1 x DED.0060.00  
1 x DED.0070.00  
1 x DED.0080.00  
1 x DED.0090.00  
1 x DED.0100.00  
1 x DED.0110.00  
1 x DED.0130.00  
1 x DED.0160.00  
1 x DED.0185.00

●  
●  
●  
●  
●  
●  
●  
●  
●  
●

Weitere Ausführungen auf Anfrage oder in der Preisliste.

Bestellbeispiel:  
SET-DED 1

More versions on request and in the price list.

order example:  
SET-DED 1



## SYSTEM DED

Einstecken mit dreischneidigen Wendeplatten

grooving with three-cutting edges indexable inserts

## Impressionen

impressions

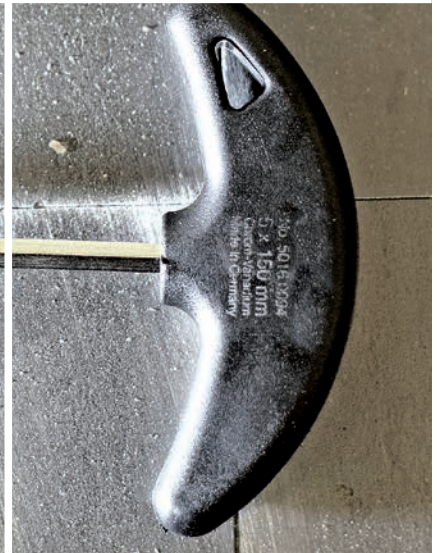
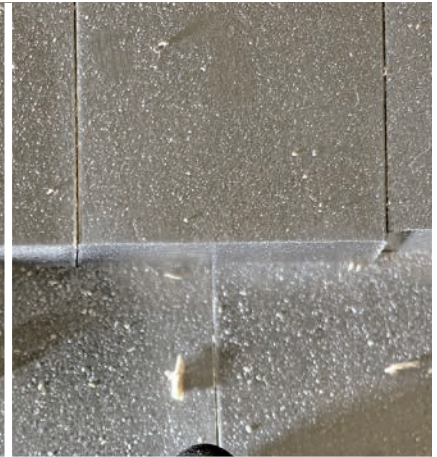



## SYSTEM ZTP

Einstecken mit  
zweischneidigen Wendeplatten

grooving with two-cutting  
edges indexable inserts

## Allgemeine Beschreibung

general instruction

### System ZTP:

Robustes System zum Einstecken mit zweischneidigen Wendeplatten ab 2mm.

#### System ZTP:

Tough system for grooving with two-cutting edges indexable inserts starting at 2 mm.

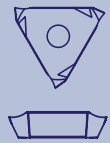
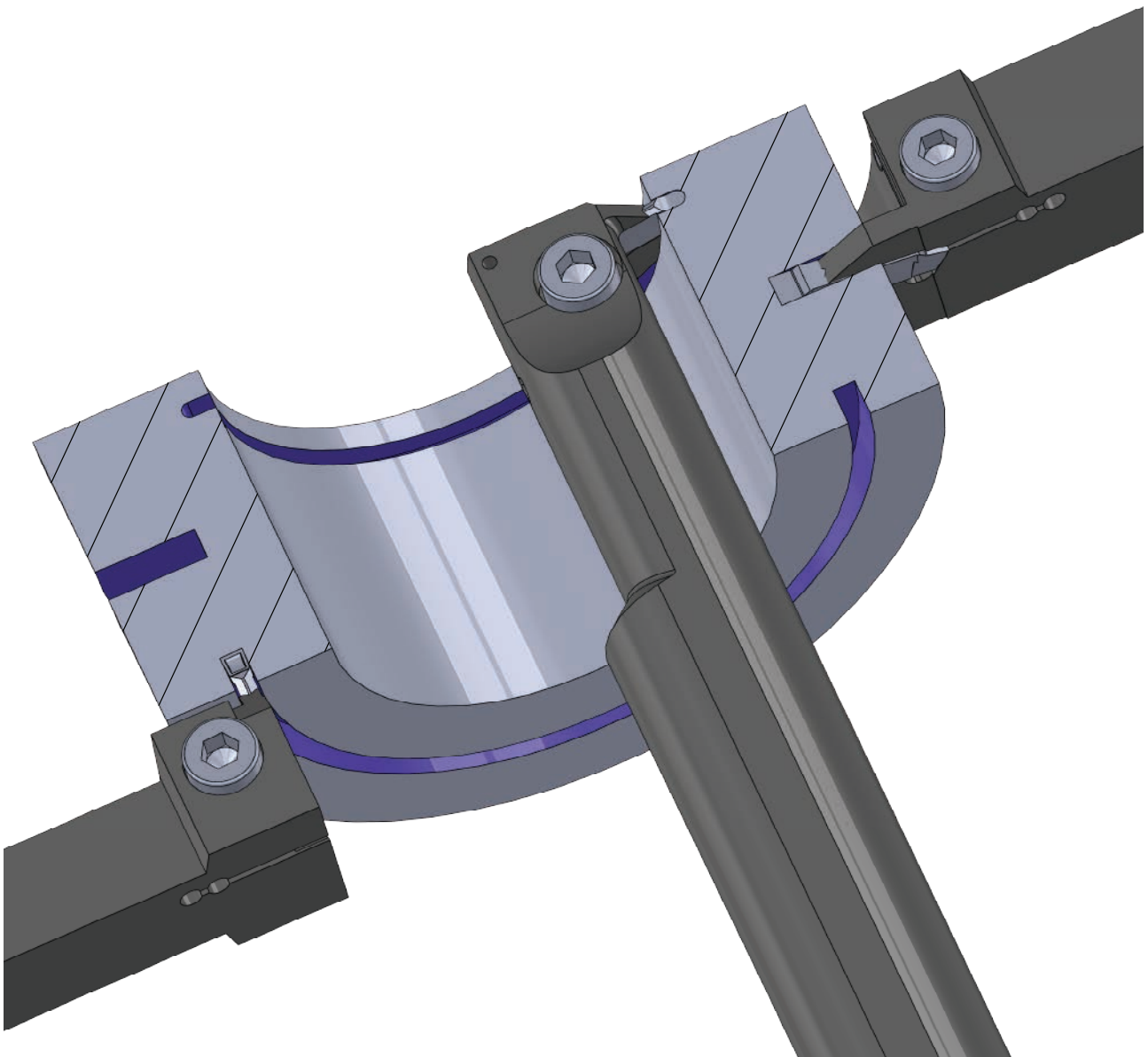

## SYSTEM ZTP

Einstecken mit  
zweischneidigen Wendeplatten

grooving with two-cutting  
edges indexable inserts

## Typ .212

Klemmhalter,  
Außenbearbeitung

toolholder,  
external application

Stechtiefe t max. 12 mm  
Spannbereich S 2.0 - 6.0 mm

depth of groove t max. 12 mm  
holding capacity S 2.0 - 6.0 mm

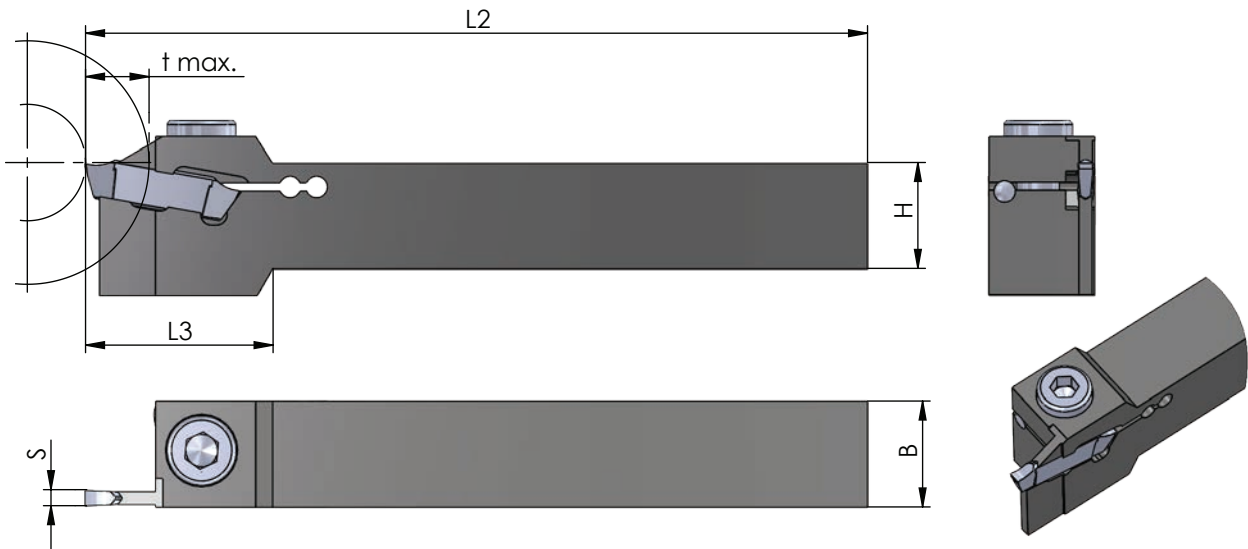

Rechts (R): wie gezeichnet  
Links (L): spiegelbildlich

righthand (R): as shown  
lefthand version (L): mirror image

Abmessungen in mm

dimensions in mm



Bestellnummer part number	H	B	t max.	L2	L3	Spannschraube screw	Schraubenschlüssel wrench	Spannbereich S holding capacity S	
								≤	Wende- schneidplatte S indexable insert S
R/L .212.1616.2-D	16	16	12	125	35				
R/L .212.2020.2-D	20	20	12	150	35	912	911	2.0 - 3.0	
R/L .212.2525.2-D	25	25	12	150	-				
R/L .212.1616.3-D	16	16	12	125	35				
R/L .212.2020.3-D	20	20	12	150	35	912	911	3.0 - 4.0	
R/L .212.2525.3-D	25	25	12	150	-				
R/L .212.3225.3-D	32	25	12	170	-				
R/L .212.2020.4-D	20	20	12	150	35				
R/L .212.2525.4-D	25	25	12	150	-	912	911	4.0 - 5.1	
R/L .212.3225.4-D	32	25	12	170	-				
R/L .212.2020.6-D	20	20	12	150	35				
R/L .212.2525.6-D	25	25	12	150	-	912	911	5.2 - 6.0	
R/L .212.3225.6-D	32	25	12	170	-				

Bestellbeispiel:  
für rechte Ausführung  
R.212.1616.2-D

order-example:  
righthand version  
R.212.1616.2-D

## SYSTEM ZTP

Einstecken mit  
zweischneidigen Wendeplatten

grooving with two-cutting  
edges indexable inserts

## Typ .220

Klemmhalter,  
Außenbearbeitung

toolholder,  
external application

Stechtiefe t max. 20 mm  
Spannbereich S 2.0 - 6.0 mm

depth of groove t max. 20 mm  
holding capacity S 2.0 - 6.0 mm

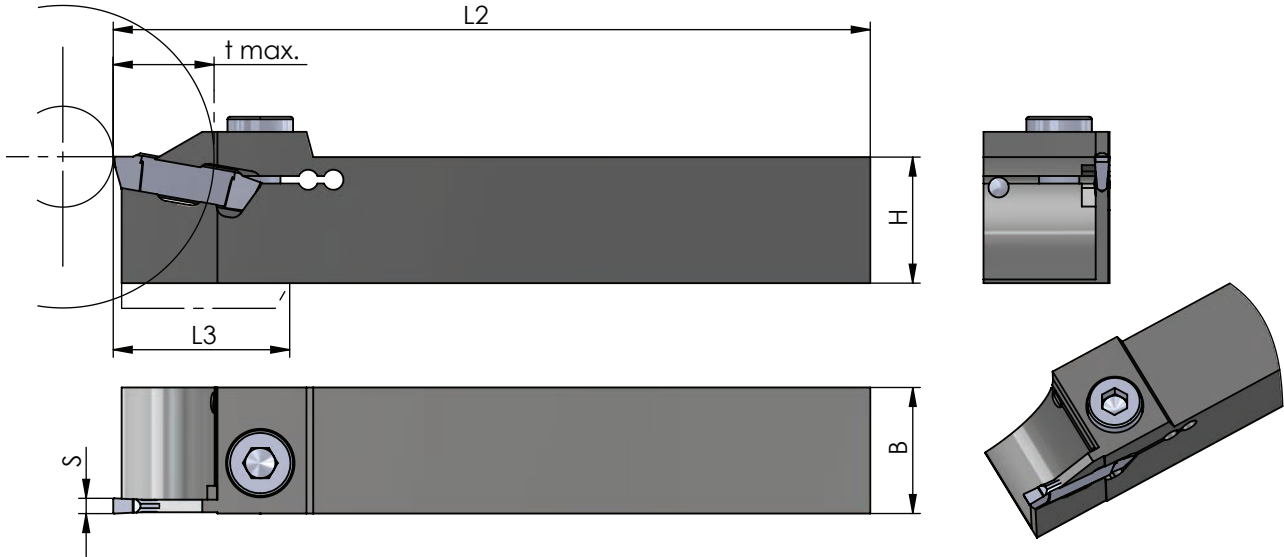

Rechts (R): wie gezeichnet  
Links (L): spiegelbildlich

righthand (R): as shown  
lefthand version (L): mirror image

Abmessungen in mm

dimensions in mm

Bestellnummer part number	H	B	* t max.	L2	L3	Spannschraube screw	Schraubenschlüssel wrench	Spannbereich S holding capacity S	Wende- schneidplatte S indexable insert S
								≤	
R/L .220.1616.2-D	16	16	20	125	45				
R/L .220.2020.2-D	20	20	20	150	45	912	911	2.0 - 3.0	
R/L .220.2525.2-D	25	25	20	150	-				
R/L .220.1616.3-D	16	16	20	125	45				
R/L .220.2020.3-D	20	20	20	150	45	912	911	3.0 - 4.0	
R/L .220.2525.3-D	25	25	20	150	-				
R/L .220.3225.3-D	32	25	20	170	-				
R/L .220.2020.4-D	20	20	20	150	45				
R/L .220.2525.4-D	25	25	20	150	-	912	911	4.0 - 5.1	
R/L .220.3225.4-D	32	25	20	170	-				
R/L .220.2020.6-D	20	20	20	150	45				
R/L .220.2525.6-D	25	25	20	150	-	912	911	5.2 - 6.0	
R/L .220.3225.6-D	32	25	20	170	-				

R/L .220. ....2-D \*tmax. reduziert bei Werkstück Ø > 50  
R/L .220. ....3-D \*tmax. reduced for workpiece Ø > 50

R/L .220. ....4-D \*tmax. reduziert bei Werkstück Ø > 100  
R/L .220. ....6-D \*tmax. reduced for workpiece Ø > 100

Bestellbeispiel:  
für rechte Ausführung  
R.220.1616.2-D

order-example:  
righthand version  
R.220.1616.2-D

## SYSTEM ZTP

Einstecken mit  
zweischneidigen Wendeplatten

grooving with two-cutting  
edges indexable inserts

## Typ .225

Klemmhalter,  
Außenbearbeitung

toolholder,  
external application

Stechtiefe t max. 25 mm  
Spannbereich S 2.0 - 6.0 mm

depth of groove t max. 25 mm  
holding capacity S 2.0 - 6.0 mm

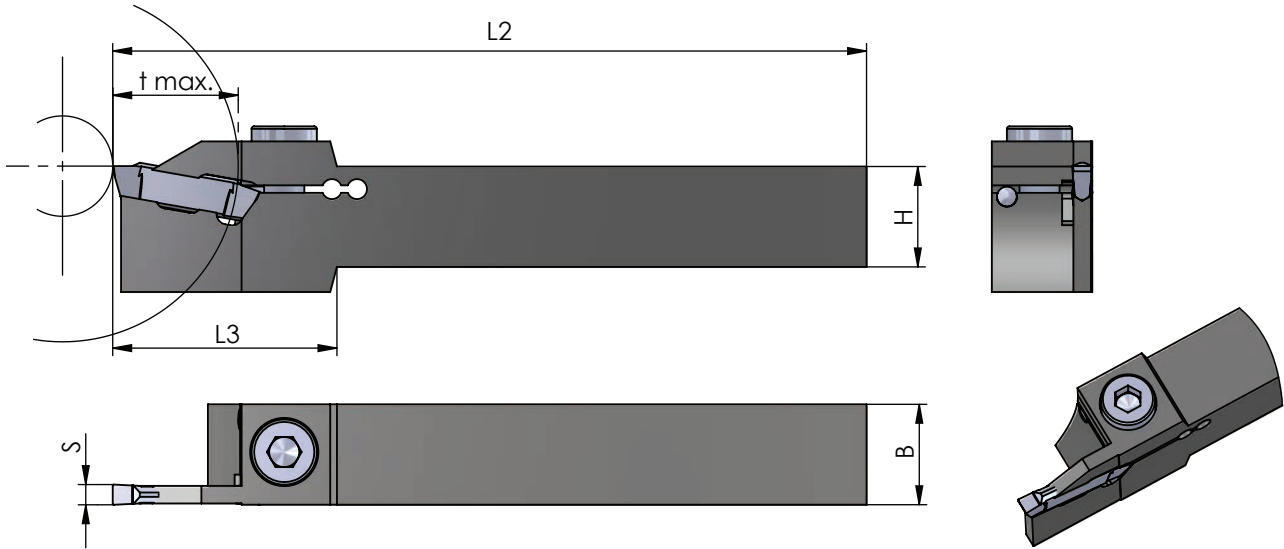

Rechts (R): wie gezeichnet  
Links (L): spiegelbildlich

righthand (R): as shown  
lefthand version (L): mirror image

Abmessungen in mm

dimensions in mm



Bestellnummer part number	H	B	*t max.	L2	L3	Spannschraube screw	Schraubenschlüssel wrench	Spannbereich S holding capacity S	
								≤	Wende- schneidplatte S indexable insert S
R/L .225.2020.2-D	20	20	25	150	45				
R/L .225.2525.2-D	25	25	25	150	-	912	911	2.0 - 3.0	
R/L .225.3225.2-D	32	25	25	170	-				
R/L .225.2020.3-D	20	20	25	150	45				
R/L .225.2525.3-D	25	25	25	150	-	912	911	3.0 - 4.0	
R/L .225.3225.3-D	32	25	25	170	-				
R/L .225.2020.4-D	20	20	25	150	45				
R/L .225.2525.4-D	25	25	25	150	-	912	911	4.0 - 5.1	
R/L .225.3225.4-D	32	25	25	170	-				
R/L .225.2020.6-D	20	20	25	150	45				
R/L .225.2525.6-D	25	25	25	150	-	912	911	5.2 - 6.0	
R/L .225.3225.6-D	32	25	25	170	-				

R/L .225. ....2-D \*tmax. reduziert bei Werkstück Ø > 50  
R/L .225. ....3-D \*tmax. reduced for workpiece Ø > 50

R/L .225. ....4-D \*tmax. reduziert bei Werkstück Ø > 100  
R/L .225. ....6-D \*tmax. reduced for workpiece Ø > 100

Bestellbeispiel:  
für rechte Ausführung  
R.225.2020.2-D

order-example:  
righthand version  
R.225.2020.2-D

## SYSTEM ZTP

Einstecken mit  
zweischneidigen Wendepplatten

grooving with two-cutting  
edges indexable inserts

## Typ .0.428

Bohrstange,  
Innenbearbeitung

grooving boring bar,  
internal application

D min. 46  
Stechtiefe t max. 15 mm  
Spannbereich S 2.0 - 6.0 mm

D min. 46  
depth of groove t max. 15 mm  
holding capacity S 2.0 - 6.0 mm

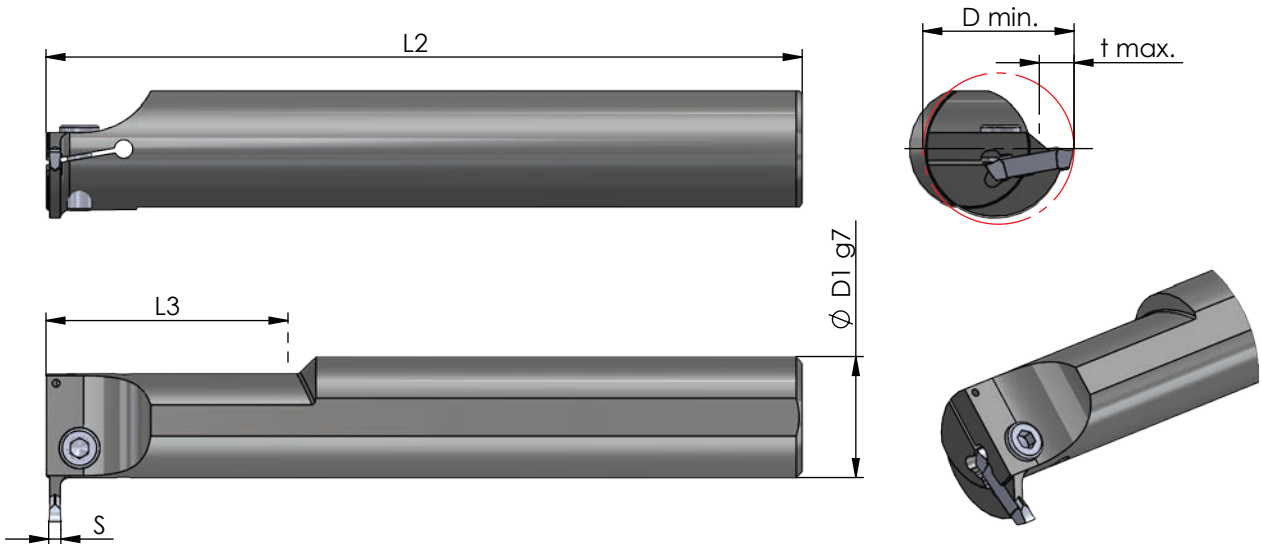

Rechts (R): wie gezeichnet  
Links (L): spiegelbildlich

righthand (R): as shown  
lefthand version (L): mirror image

Abmessungen in mm

dimensions in mm

Bestellnummer part number	Ø D1 g7	D min.	t max.	L2	L3	Spannschraube screw	Schrauben- schlüssel wrench	Spannbereich S holding capacity S	Wende- schneidplatte S indexable insert S
R/L .0.428.0032.2-D	32	46	11.5	200	70			2.0 - 3.0	
R/L .0.428.0040.2-D	40	50	11.5	250	80	912	911	2.0 - 3.0	
R/L .0.428.0050.2-D	50	60	15.0	250	100				
R/L .0.428.0032.3-D	32	46	11.5	200	70			3.0 - 4.0	
R/L .0.428.0040.3-D	40	50	11.5	250	80	912	911	3.0 - 4.0	
R/L .0.428.0050.3-D	50	60	15.0	250	100				
R/L .0.428.0032.4-D	32	46	11.5	200	70			4.0 - 5.1	
R/L .0.428.0040.4-D	40	50	11.5	250	80	912	911	4.0 - 5.1	
R/L .0.428.0050.4-D	50	60	15.0	250	100				
R/L .0.428.0032.6-D	32	46	11.5	200	70			5.2 - 6.0	
R/L .0.428.0040.6-D	40	50	11.5	250	80	912	911	5.2 - 6.0	
R/L .0.428.0050.6-D	50	60	15.0	250	100				

Bestellbeispiel:  
für rechte Ausführung  
R.0.428.0032.2-D

order-example:  
righthand version  
R.0.428.0032.2-D

## SYSTEM ZTP

Einstecken mit  
zweischneidigen Wendeplatten

grooving with two-cutting  
edges indexable inserts

## Typ .280

Klemmhalter,  
Axialbearbeitung

toolholder,  
face grooving

D min. 40  
Stechtiefe t max. 8 mm  
Spannbereich S 4.0 - 6.0 mm

D min. 40  
depth of groove t max. 8 mm  
holding capacity S 4.0 - 6.0 mm

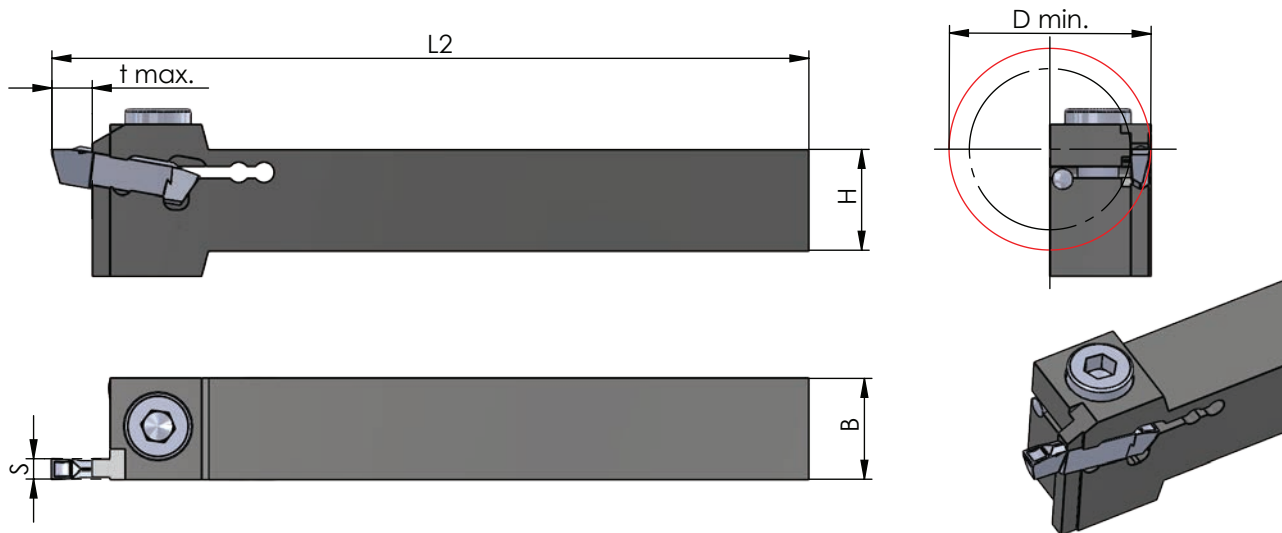

Rechts (R): wie gezeichnet  
Links (L): spiegelbildlich

righthand (R): as shown  
lefthand version (L): mirror image

Abmessungen in mm

dimensions in mm



Bestellnummer part number	H	B	D min.	t max.	L2	Spannschraube screw	Schrauben- schlüssel wrench	Spannbereich S holding capacity S	
								<=	Wende- schneidplatte S indexable insert S
R/L .280.2020.4-D	20	20	40	8	150	912	911	4.0 - 5.1	
R/L .280.2525.4-D	25	25	40	8	150			5.2 - 6.0	
R/L .280.2020.6-D	20	20	40	8	150	912	911	4.0 - 5.1	
R/L .280.2525.6-D	25	25	40	8	150			5.2 - 6.0	

Bestellbeispiel:  
für rechte Ausführung  
R.280.2020.4-D

order-example:  
righthand version  
R.280.2020.4-D

## SYSTEM ZTP

Einstecken mit  
zweischneidigen Wendepplatten

grooving with two-cutting  
edges indexable inserts

## Typ .281

Klemmhalter,  
Axialbearbeitung

toolholder,  
face grooving

D min. 40  
Stechtiefe t max. 8.5 mm  
Spannbereich S 4.0 - 6.0 mm

D min. 40  
depth of groove t max. 8.5 mm  
holding capacity S 4.0 - 6.0 mm

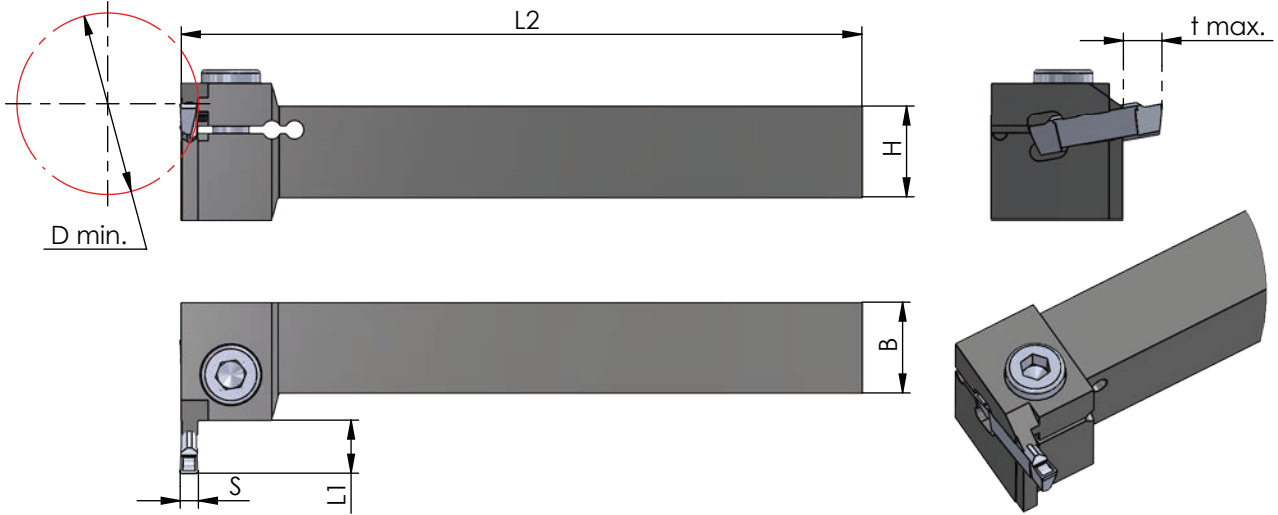

Rechts (R): wie gezeichnet  
Links (L): spiegelbildlich

righthand (R): as shown  
lefthand version (L): mirror image

Abmessungen in mm

dimensions in mm

Bestellnummer part number	H	B	D min.	t max.	L2	L1	Spannschraube screw	Schrauben- schlüssel wrench	Spannbereich S holding capacity S		Wende- schneidplatte S indexable insert S
									<	<	
R/L .281.2020.4-D	20	20	40	8.5	150	11	912	911	4.0 - 5.1		
R/L .281.2525.4-D	25	25	40	8.5	150	11			5.2 - 6.0		
R/L .281.2020.6-D	20	20	40	8.5	150	11	912	911	4.0 - 5.1		
R/L .281.2525.6-D	25	25	40	8.5	150	11			5.2 - 6.0		

Bestellbeispiel:  
für rechte Ausführung  
R.281.2020.4-D

order-example:  
righthand version  
R.281.2020.4-D

## SYSTEM ZTP

Einstecken mit  
zweischneidigen Wendeplatten

grooving with two-cutting  
edges indexable inserts

## Typ Stechdrehen .... .10

Wendeschneidplatte,  
mit runder Spannutt

indexable insert,  
with round chipbreaker

Stechbreite S 2.0 - 6.0 mm

width of groove S 2.0 - 6.0 mm

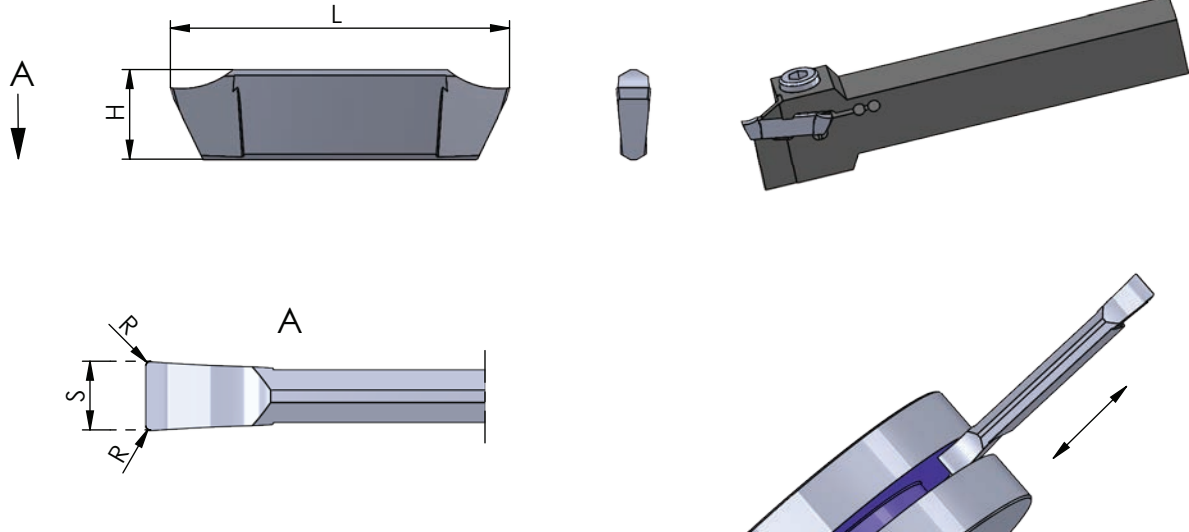

Wendeschneidplatten sind in  
rechten und linken Klemmhaltern  
sowie Bohrstängen verwendbar

inserts can be used in RH and LH  
toolholders as well as in boring  
bars

Abmessungen in mm

dimensions in mm



Bestellnummer part number	S +0.05	H	R	L	Klemmhalter Typ toolholder type			
					K10F	CN45F	AL41F	P07C
ZTP.0200.10	2.0	7.9	0.2	29.9	●	●	●	R/L .212. .... .2-D R/L .220. .... .2-D R/L .225. .... .2-D R/L .0.428. .... .2-D
ZTP.0300.10	3.0	7.9	0.2	29.9	●	●	●	R/L .212. .... .3-D R/L .220. .... .3-D R/L .225. .... .3-D R/L .0.428. .... .3-D
ZTP.0400.10	4.0	7.9	0.2	29.9	●	●	●	R/L .212. .... .4-D R/L .220. .... .4-D
ZTP.0500.10	5.0	7.9	0.2	29.9	●	●	●	R/L .225. .... .4-D R/L .0.428. .... .4-D
ZTP.0600.10	6.0	7.5	0.4	29.9	●	●	●	R/L .212. .... .6-D R/L .220. .... .6-D R/L .225. .... .6-D R/L .0.428. .... .6-D

Weitere HM Sorten können Sie in der Sorten-  
übersicht im Kapitel "Technische Hinweise" und  
der Preisliste finden.

Bestellbeispiel:  
für Sorte AL41F:  
ZTP.0200.10/AL41F

More carbide grades you can find in the grades  
summary in the chapter "technical instructions"  
and in the price list.

order-example:  
grade AL41F:  
ZTP.0200.10/AL41F

**BROTECH**



## SYSTEM ZTP

Einstecken mit  
zweischneidigen Wendeplatten

grooving with two-cutting  
edges indexable inserts

## Typ Stechdrehen .... .20

Wendeschneidplatte,  
mit ebener Spanfläche

indexable insert,  
with flat chipbreaker

Stechbreite S 2.0 - 6.0 mm

width of groove S 2.0 - 6.0 mm

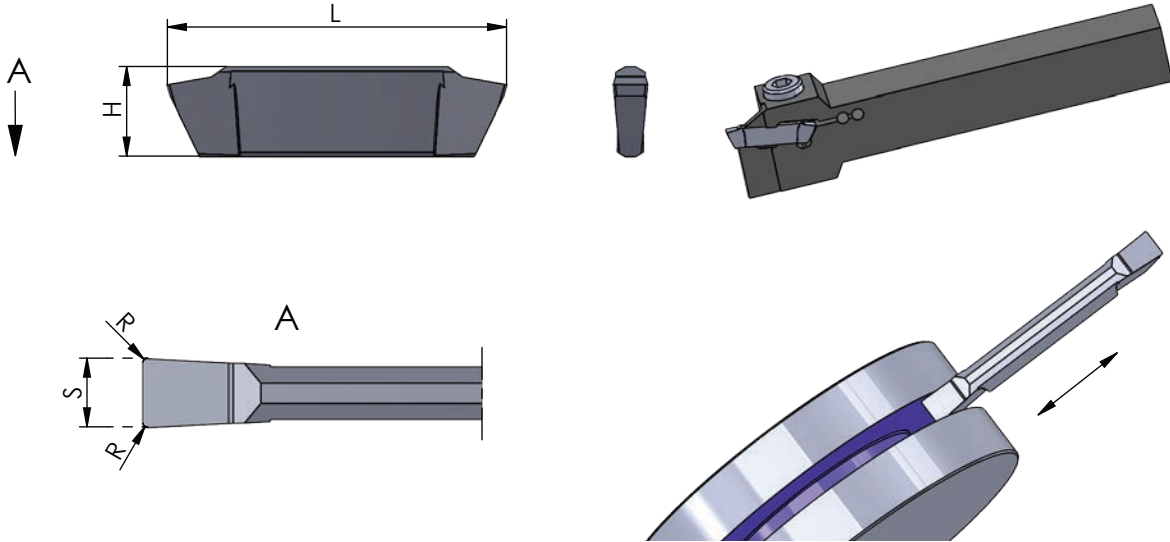

Wendeschneidplatten sind in  
rechten und linken Klemmhaltern  
sowie Bohrstängen verwendbar

inserts can be used in RH and LH  
toolholders as well as in boring  
bars

Abmessungen in mm

dimensions in mm

Bestellnummer part number	S +0.05	H	R	L	K10F	CN45F	AL41F	P07C	Klemmhalter Typ	toolholder type
ZTP.0200.20	2.0	7.9	0.2	29.9	●	●	●		R/L .212. .... .2-D R/L .220. .... .2-D R/L .225. .... .2-D R/L .0.428. .... .2-D	
ZTP.0300.20	3.0	7.9	0.2	29.9	●	●	●		R/L .212. .... .3-D R/L .220. .... .3-D R/L .225. .... .3-D R/L .0.428. .... .3-D	
ZTP.0400.20	4.0	7.9	0.2	29.9	●	●	●		R/L .212. .... .4-D R/L .220. .... .4-D R/L .225. .... .4-D R/L .0.428. .... .4-D	
ZTP.0500.20	5.0	7.9	0.2	29.9	●	●	●		R/L .212. .... .6-D R/L .220. .... .6-D R/L .225. .... .6-D R/L .0.428. .... .6-D	
ZTP.0600.20	6.0	7.5	0.4	29.9	●	●	●		R/L .212. .... .6-D R/L .220. .... .6-D R/L .225. .... .6-D R/L .0.428. .... .6-D	

Weitere HM Sorten können Sie in der Sorten-  
übersicht im Kapitel "Technische Hinweise" und  
der Preisliste finden.

Bestellbeispiel:  
für Sorte AL41F:  
ZTP.0200.20/AL41F

More carbide grades you can find in the grades  
summary in the chapter "technical instructions"  
and in the price list.

order-example:  
grade AL41F:  
ZTP.0200.20/AL41F

**BROTECH**

## SYSTEM ZTP

Einstecken mit  
zweischneidigen Wendeplatten

grooving with two-cutting  
edges indexable inserts

## Typ Stechdrehen .... .30

Wendeschneidplatte,  
mit Spanformer

indexable insert,  
with chipformer

Stechbreite S 2.0 - 6.0 mm

width of groove S 2.0 - 6.0 mm

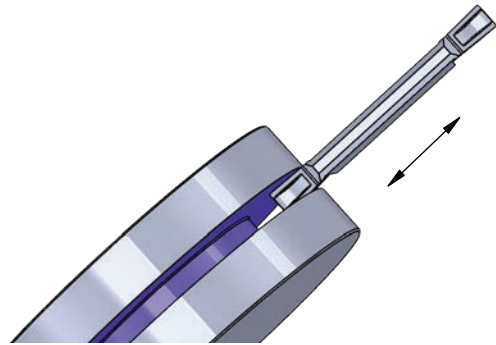
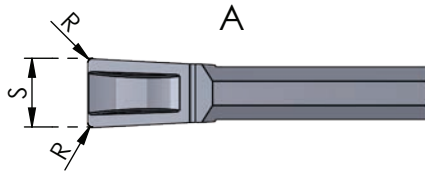
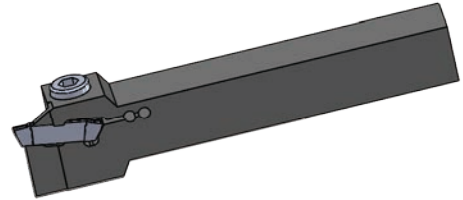
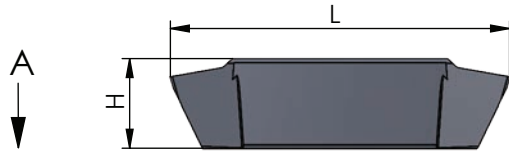

Wendeschneidplatten sind in  
rechten und linken Klemmhaltern  
sowie Bohrstängen verwendbar

inserts can be used in RH and LH  
toolholders as well as in boring  
bars

Abmessungen in mm

dimensions in mm



Bestellnummer part number	S +0.05	H	R	L	K10F	CN45F	AL41F	P07C	Klemmhalter Typ	toolholder type
ZTP.0200.30	2.0	7.9	0.2	29.9	●	●	●		R/L .212. .... .2-D R/L .220. .... .2-D R/L .225. .... .2-D R/L .0.428. .... .2-D	
ZTP.0300.30	3.0	7.9	0.2	29.9	●	●	●		R/L .212. .... .3-D R/L .220. .... .3-D R/L .225. .... .3-D R/L .0.428. .... .3-D	
ZTP.0400.30	4.0	7.9	0.2	29.9	●	●	●		R/L .212. .... .4-D R/L .220. .... .4-D R/L .225. .... .4-D R/L .0.428. .... .4-D	
ZTP.0500.30	5.0	7.9	0.2	29.9	●	●	●		R/L .212. .... .6-D R/L .220. .... .6-D R/L .225. .... .6-D R/L .0.428. .... .6-D	
ZTP.0600.30	6.0	7.5	0.4	29.9	●	●	●		R/L .212. .... .6-D R/L .220. .... .6-D R/L .225. .... .6-D R/L .0.428. .... .6-D	

Weitere HM Sorten können Sie in der Sorten-  
übersicht im Kapitel "Technische Hinweise" und  
der Preisliste finden.

Bestellbeispiel:  
für Sorte AL41F:  
ZTP.0200.30/AL41F

More carbide grades you can find in the grades  
summary in the chapter "technical instructions"  
and in the price list.

order-example:  
grade AL41F:  
ZTP.0200.30/AL41F

**BROTECH**

## SYSTEM ZTP

Einstecken mit  
zweischneidigen Wendeplatten

grooving with two-cutting  
edges indexable inserts

## Typ Stechdrehen ZTP.R

Wendeschneidplatte,  
mit Vollradius  
und runder Spannt

indexable insert,  
with full radius  
and round chipbreaker

Stechbreite S 2.0 - 6.0 mm

width of groove S 2.0 - 6.0 mm

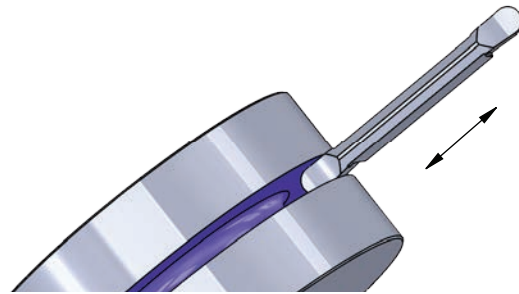
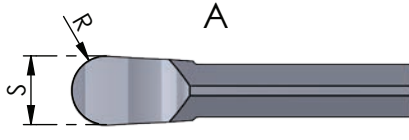
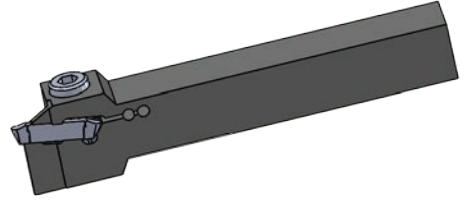
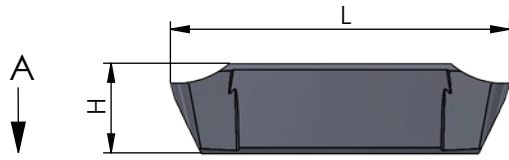

Wendeschneidplatten sind in  
rechten und linken Klemmhaltern  
sowie Bohrstängen verwendbar

inserts can be used in RH and LH  
toolholders as well as in boring  
bars

Abmessungen in mm

dimensions in mm

Bestellnummer part number	S +0.05	R	H	L	Klemmhalter Typ toolholder type				
					K10F	CN45F	AL41F	P07C	
ZTP.R010.20	2.0	1.0	7.9	29.9	●	●			R/L .212. .... 2-D R/L .220. .... 2-D R/L .225. .... 2-D R/L .0.428. .... 2-D
ZTP.R015.30	3.0	1.5	7.9	29.9	●	●			R/L .212. .... 3-D R/L .220. .... 3-D R/L .225. .... 3-D R/L .0.428. .... 3-D
ZTP.R020.40	4.0	2.0	7.9	29.9	●	●			R/L .212. .... 4-D R/L .220. .... 4-D
ZTP.R025.50	5.0	2.5	7.9	29.9			●		R/L .225. .... 4-D R/L .0.428. .... 4-D
ZTP.R030.60	6.0	3.0	7.5	29.9			●		R/L .212. .... 6-D R/L .220. .... 6-D R/L .225. .... 6-D R/L .0.428. .... 6-D

Weitere HM Sorten können Sie in der Sorten-  
übersicht im Kapitel "Technische Hinweise" und  
der Preisliste finden.

Bestellbeispiel:  
für Sorte AL41F:  
ZTP.R010.20/AL41F

More carbide grades you can find in the grades  
summary in the chapter "technical instructions"  
and in the price list.

order-example:  
grade AL41F:  
ZTP.R010.20/AL41F

**BROTECH**

## SYSTEM ZTP

Einstecken mit  
zweischneidigen Wendeplatten

grooving with two-cutting  
edges indexable inserts

## Typ Stechdrehen / Abstechen

Wendeschneidplatte,  
mit Spanformer

indexable insert,  
with chipformer,  
for parting off

Stechbreite S 2.0 - 4.0 mm

width of groove S 2.0 - 4.0 mm

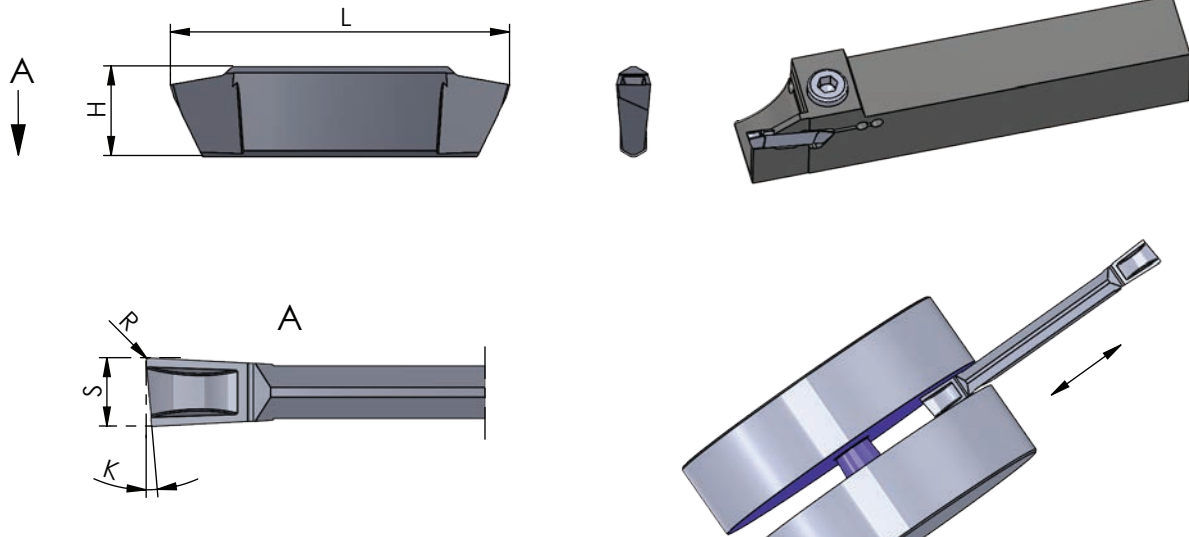

Rechts (R): wie gezeichnet  
Links (L): spiegelbildlich

Wendeschneidplatten sind in  
rechten und linken Klemmhaltern  
verwendbar.  
Abmessungen in mm

righthand version (R): as shown  
lefthand version (L): mirror image

inserts can be used in RH and LH  
toolholders

dimensions in mm



Bestellnummer part number	S ±0.05	K	R	H	L	Klemmhalter Typ toolholder type				
						K10F	CN45F	AL41F	P07C	
R/L .ZTP.5200.30	2.0	5°	0.2	7.9	29.9	●	●	●		R/L .12. .... 2-D R/L .220. .... 2-D R/L .225. .... 2-D
R/L .ZTP.5300.30	3.0	5°	0.2	7.9	29.9	●	●	●		R/L .12. .... 3-D R/L .220. .... 3-D R/L .225. .... 3-D
R/L .ZTP.5400.30	4.0	5°	0.2	7.9	29.9	●	●	●		R/L .12. .... 4-D R/L .220. .... 4-D R/L .225. .... 4-D

Weitere HM Sorten können Sie in der Sorten-  
übersicht im Kapitel "Technische Hinweise" und  
der Preisliste finden.

Bestellbeispiel:  
für rechte Ausführung und Sorte:  
R.ZTP.5200.30/AL41F

More carbide grades you can find in the grades  
summary in the chapter "technical instructions"  
and in the price list.

order-example:  
righthand version and grade:  
R.ZTP.5200.30/AL41F

**BROTECH**

## SYSTEM ZTP

Einstecken mit  
zweischneidigen Wendeplatten

grooving with two-cutting  
edges indexable inserts

## Typ Stechdrehen / Längsdrehen

Wendeschneidplatte,  
mit Spanformer

indexable insert,  
with chipformer,  
grooving and turning

Stechbreite S 3.0 - 6.0 mm

width of groove S 3.0 - 6.0 mm

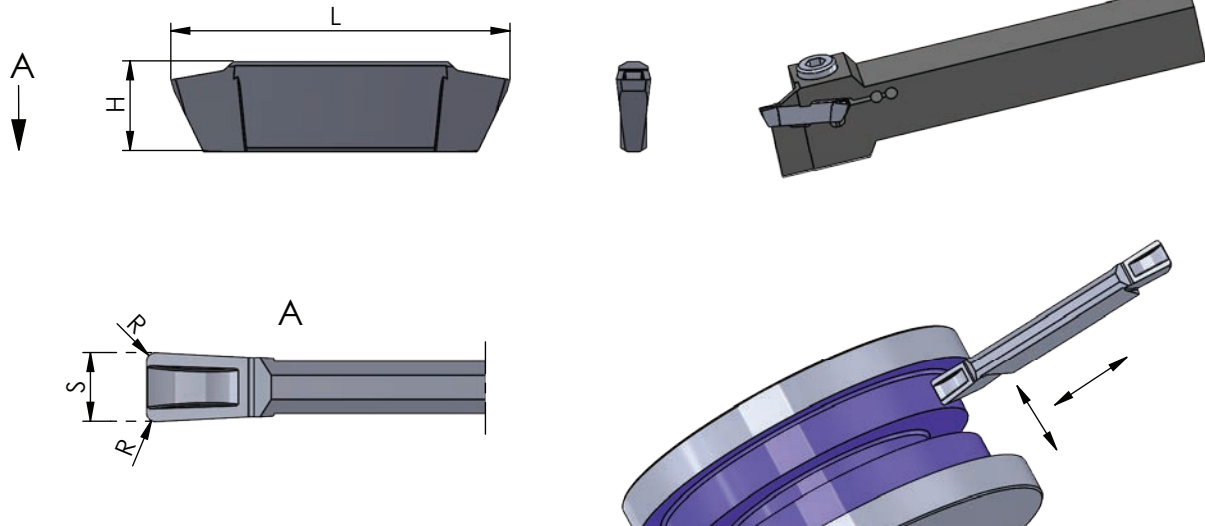

Wendeschneidplatten sind in  
rechten und linken Klemmhaltern  
sowie Bohrstängen verwendbar

inserts can be used in RH and LH  
toolholders as well as in boring  
bars

Abmessungen in mm

dimensions in mm

Bestellnummer part number	S +0.05	H	R	L	Klemmhalter Typ toolholder type			
					K10F	CN45F	AL41F	P07C
ZTP.0300.34	3.0	7.9	0.4	29.9	●	●	●	R/L .212. .... 3-D R/L .220. .... 3-D R/L .225. .... 3-D R/L .0.428. .... 3-D
ZTP.0400.34	4.0	7.9	0.4	29.9	●	●	●	R/L .212. .... 4-D R/L .220. .... 4-D
ZTP.0500.34	5.0	7.9	0.4	29.9	●	●	●	R/L .225. .... 4-D R/L .0.428. .... 4-D
ZTP.0600.34	6.0	7.5	0.8	29.9	●	●	●	R/L .212. .... 6-D R/L .220. .... 6-D R/L .225. .... 6-D R/L .0.428. .... 6-D

Weitere HM Sorten können Sie in der Sorten-  
übersicht im Kapitel "Technische Hinweise" und  
der Preisliste finden.

Bestellbeispiel:  
für Sorte AL41F:  
ZTP.0300.34/AL41F

More carbide grades you can find in the grades  
summary in the chapter "technical instructions"  
and in the price list.

order-example:  
grade AL41F:  
ZTP.0300.34/AL41F

**BROTECH**

## SYSTEM ZTP

Einstecken mit  
zweischneidigen Wendeplatten

grooving with two-cutting  
edges indexable inserts

## Typ Stechdrehen / Axialbearbeitung

Wendeschneidplatte,  
mit Spanformer

indexable insert,  
with chipformer,  
face grooving

D min. 40 mm  
Stechbreite S 4.0 - 6.0 mm

D min. 40 mm  
width of groove S 4.0 - 6.0 mm

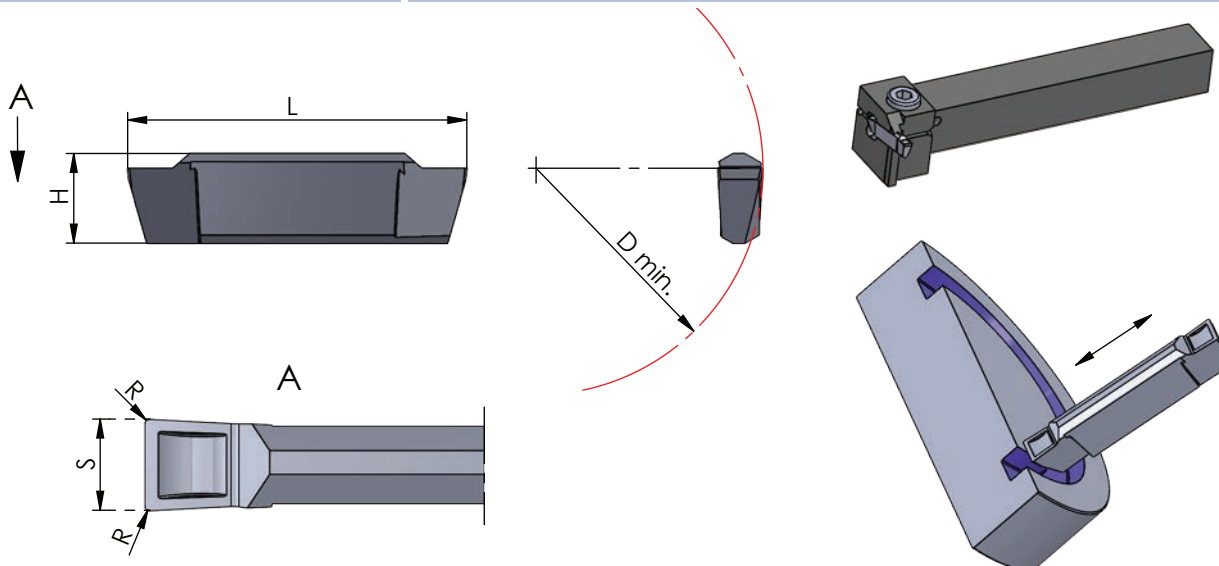

Rechts (R): wie gezeichnet  
Links (L): spiegelbildlich

Wendeschneidplatten sind in  
rechten und linken Klemmhaltern  
verwendbar  
Abmessungen in mm

righthand version (R): as shown  
lefthand version (L): mirror image

inserts can be used in RH and LH  
toolholders

dimensions in mm

Bestellnummer part number	S +0.05	H	R	L	D min.	Klemmhalter Typ toolholder type				
						K10F	CN45F	AL41F	P07C	
R/L .ZTP.4040.34	4.0	7.9	0.2	29.9	40	●	●	●		R/L .280. .... .4-D R/L .281. .... .4-D
R/L .ZTP.4050.34	5.0	7.9	0.4	29.9	40	●	●	●		
R/L .ZTP.4060.34	6.0	7.5	0.4	29.9	40		●	●		R/L .280. .... .6-D R/L .281. .... .6-D

Weitere HM Sorten können Sie in der Sorten-  
übersicht im Kapitel "Technische Hinweise" und  
der Preisliste finden.

Bestellbeispiel:  
für rechte Ausführung und Sorte:  
R.ZTP.4040.34/AL41F

More carbide grades you can find in the grades  
summary in the chapter "technical instructions"  
and in the price list.

order-example:  
righthand version and grade:  
R.ZTP.4040.34/AL41F

**BROTECH**

## SYSTEM DED / ZTP

Einstecken mit  
zwei- und dreischneidigen  
Wendeplatten

grooving with  
two and three-cutting edges  
indexable inserts

## Technische Hinweise

Hartmetallsorten und Beschichtungen

Technical instructions,  
carbide grades and coatings

### K10F

Universell einsetzbares Feinkornhartmetall mit guter Verschleißfestigkeit. Unbeschichtet geeignet für Anwendungen mit niedrigen und mittleren Schnittgeschwindigkeiten, sowie die Bearbeitung von Nicht-eisenmetallen.

All purpose micrograin carbide with good abrasion resistance. Uncoated for applications with low or medium cutting speeds and machining of non-ferrous materials.

### CBN

Zähe CBN-Sorte für Anwendungen mit niedrigen Schnittgeschwindigkeiten. Geeignet für gehärtete Stähle, unterbrochene Schnitte und Grauguss.

Ductile CBN grade for applications with lower cutting speed. Suitable for hardened steel, interrupted cuts and cast iron.

### CN45F

Universell einsetzbare PVD-TIN-Beschichtung. Diese Allround-Sorte ist für niedrige und mittlere Schnittgeschwindigkeiten mit Einschränkung bei NE-Metallen

PVD-TIN coating - all purpose, all around grade is suitable for low and medium cutting speed with restrictions on non-ferrous materials.

### AL41F

Sehr universell einsetzbare TIALN-Beschichtung mit hoher Temperaturbeständigkeit bei hoher Härte. Sehr gut geeignet auch für NE-Metalle.

TIALN coating - very universal with a high resistance to high temperature and hardness. Very suitable also for non-ferrous metals.

### PD2F

Beschichtung für den universellen Einsatz bei niedrigen und mittleren Schnittgeschwindigkeiten.

Coating for universal use with medium and low speed.

### XC2A

Beschichtung mit einer excellenten Warmhärte, Oxidationsbeständigkeit und thermischen Isolationsfähigkeit. Ideal für Hartzerspannung >60HRC

Coating with excellent hot hardness, high oxidation resistance and thermal insulation capacity. Perfect for hard machining >60 HRC.

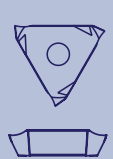

## SYSTEM DED / ZTP

Einstecken mit  
zwei- und dreischneidigen  
Wendeplatten

grooving with  
two and three-cutting edges  
indexable inserts

## Technische Hinweise

Hartmetallsorten und Beschichtungen

Technical instructions,  
carbide grades and coatings

### P01C

Beschichtung für die Bearbeitung in zähen Materialien bei niedrigen und mittleren Schnittgeschwindigkeiten.

Coating for the processing in tough material with medium or low cutting speed

### P03C

Beschichtung für die Bearbeitung von schwer zerspanbaren Materialien. Sehr gut auch für die Trockenbearbeitung geeignet.

Coating for materials which are difficult to machine. Perfect to use for dry machining.

### P07C

Beschichtung für die Bearbeitung von Titan, Edelstahl und Molybdän.

Coating to machine titanium, stainless steel and molybdenum.

### P18C

Universell einsetzbare Hochleistungsschicht mit hoher Oxidationsbeständigkeit, Verschleißfestigkeit und Warmhärte.

Very universal high performance coating with high oxidation resistance, wear resistance and hot hardness resistance.

### NEME

Beschichtung für die Bearbeitung von Aluminium, Al-Legierungen, NE-Metallen und Composite-Werkstoffen.

Coating for machining aluminium, alloys, non-ferrous metals and composite materials.





# SYSTEM DED / ZTP

Einstechen mit  
zwei- und dreischneidigen  
Wendepplatten

grooving with  
two and three-cutting edges  
indexable inserts

# Technische Hinweise

Schnittdaten

Technical instructions,  
cutting data

	Werkstoff	Festigkeit	Werkstoff-Nr	Werkstoffbezeichnung	Werkstoff-Nr
P	Allgemeiner Baustahl	< 800 N/mm <sup>2</sup>	1.0037	St37-2	1.0570
	Automatenstahl	< 800 N/mm <sup>2</sup>	1.0718	9SMnPb28	1.0727
	Einsatzstahl unlegiert	< 800 N/mm <sup>2</sup>	1.0401	C15	1.0481
	Einsatzstahl legiert	< 1000 N/mm <sup>2</sup>	1.7331	16MnCr5 (EC80)	1.7015
	Vergütungsstahl unlegiert	< 850 N/mm <sup>2</sup>	1.0503	C45	1.1191
	Vergütungsstahl unlegiert	< 1000 N/mm <sup>2</sup>	1.0601	C60	1.1221
	Vergütungsstahl legiert	< 800 N/mm <sup>2</sup>	1.5131	50MnSi4	1.7030
	Vergütungsstahl legiert	< 1300 N/mm <sup>2</sup>	1.5755	31NiCr14	1.7033
	Stahlguss	< 850 N/mm <sup>2</sup>	0.9650	G-X260Cr27	1.6750
	Nitrierstahl	< 1000 N/mm <sup>2</sup>	1.8504	34CrAl6	1.8507
	Nitrierstahl	< 1200 N/mm <sup>2</sup>	1.8515	31CrMo12	1.8523
	Wälzlagerstahl	< 1200 N/mm <sup>2</sup>	1.3505	100Cr6 (W3)	1.3543
	Federstahl	< 1200 N/mm <sup>2</sup>	1.5026	55Si7	1.7176
	Schnellarbeitsstahl	< 1300 N/mm <sup>2</sup>	1.3344	S 6-5-3	1.3255
	Werkzeugstahl für Kaltarbeit	< 1300 N/mm <sup>2</sup>	1.2312	40CrMnMoS8 6	1.2379
	Werkzeugstahl für Warmbeit	< 1300 N/mm <sup>2</sup>	1.2343	X38CrMoV 5 1	1.2767
M	Stahl und Stahlguss rostfrei geschwefelt	< 850 N/mm <sup>2</sup>	1.4305	X8CrNiS18 9	1.4105
	Nichtrostender Stahl, ferritisch	< 750 N/mm <sup>2</sup>	1.4510	X3CrTi17	1.4528
	Nichtrostender Stahl, martensitisch	< 900 N/mm <sup>2</sup>	1.4034	X46Cr13	1.4116
	Nichtrost. Stahl, ferritisch/martensit.	<1100 N/mm <sup>2</sup>	1.4313	X3CrNi13-4	1.4028
	Nichtrost. Stahl, austenitisch/ferritisch	< 850 N/mm <sup>2</sup>	1.4460	X8CrNiMo27 5	1.4821
	Nichtrostender Stahl, austenitisch	< 750 N/mm <sup>2</sup>	1.4301	X5CrNi18-10	1.4571
	Hitzebeständig	< 1100 N/mm <sup>2</sup>	1.4747	X80CrNiSi20	1.4876
K	Grauguss mit Lammellengraphit	100-350N/mm <sup>2</sup>	0.6010	GG10	0.6025
	Grauguss mit Lammellengraphit	300-1000N/mm <sup>2</sup>	0.6030	GG30	0.6045
	Kugelgraphitguss	300-500N/mm <sup>2</sup>	0.7040	GGG40	0.7050
	Kugelgraphitguss	550-800N/mm <sup>2</sup>	0.7060	GGG60	0.7080
	Temperguss weis	350-450N/mm <sup>2</sup>	0.8035	GTW35	0.8045
	Temperguss weis	500-650N/mm <sup>2</sup>	0.8055	GTW55	0.8065
	Temperguss schwarz	350-450N/mm <sup>2</sup>	0.8135	GTS35	0.8145
Temperguss schwarz	500-700N/mm <sup>2</sup>	0.8155	GTS55	0.8170	
N	Aluminium ( unlegiert, niedrig legiert )	< 350 N/mm <sup>2</sup>	3.0255	Al99,5	3.3308
	Aluminiumlegierungen < 0,5% Si	< 500 N/mm <sup>2</sup>	3.0515	AlMn1	3.1355
	Aluminiumlegierungen 0,5-10% Si	< 400 N/mm <sup>2</sup>	3.2152	GD-AlSi6Cu4	3.2373
	Aluminiumlegierungen 10-15% Si	< 400 N/mm <sup>2</sup>	3.2381	G-AlSi10Mg	3.5562
	Aluminiumlegierungen > 15% Si	< 400 N/mm <sup>2</sup>		G-AlSi17Cu4	
	Kupfer ( unlegiert, niedrig legiert )	< 350 N/mm <sup>2</sup>	2.0060	E-Cu57	2.0090
	Kupfer-Knetlegierungen	< 700 N/mm <sup>2</sup>	2.0240	CuZn15	2.0265
	Kupfer-Sonderlegierungen	< 200 HB	2.0916	CuAl5	2.1525
	Kupfer-Sonderlegierungen	< 300HB	2.0978	CuAl11Ni6Fe5	
	Kupfer-Sonderlegierungen	> 300 HB	2.1247	CuBe2F125	
	Messing kurzspanend, Bronze, Rotguss	< 600 N/mm <sup>2</sup>	2.0360	CuZn40 (Ms60)	2.0380
	Messing langspanend	< 600 N/mm <sup>2</sup>	2.0335	CuZn36 (Ms63)	2.1293
	Thermoplaste			Delrin, Hostalen	
	Duroplaste			Ferrozell, Bakelit	
	Faserverstärkte Kunststoffe			GFK (Glasfaserverstärkt )	
	Magnesium und Magnesiumlegierungen	< 850 N/mm <sup>2</sup>	3.5200	M2, MgMn2	3.5612
	Graphit			C8000, R8500X	
Wolfram und Wolframlegierungen			W-NiFe (Densimet W)		
Molybdän und Molybdänlegierungen			Mo , Mo-50Re		
S	Reinnickel		1.3911	RNi24	1.3927
	Nickellegierungen		1.3912	Ni36 (Invar)	1.3924
	Nickellegierungen	< 850 N/mm <sup>2</sup>	2.4360	S-NiCu 30 Fe	
	Nickel-Chromlegierungen		2.4886	SG-NiMo16Cr16W	2.4610
	Nickel- und Kobaltlegierungen	< 1300 N/mm <sup>2</sup>	2.4632	NiCr20Co18Ti	2.4631
	Nickel- und Kobaltlegierungen	< 1300 N/mm <sup>2</sup>	2.4634	NiCo20Cr15MoAlTi	2.4654
	Hochwärmefeste Legierungen	< 1300 N/mm <sup>2</sup>		Hardox 400	1.4939
	Nickel-Kobalt-(Chrom-)legierungen	< 1400 N/mm <sup>2</sup>	2.4806	SG-NiCr20Nb, Inconel 82	2.4851
	Reintitan	< 900 N/mm <sup>2</sup>	3.7025	Ti99,8	3.7034
	Titanlegierungen	< 700 N/mm <sup>2</sup>	3.7114	TiAl5Sn2	3.7174
Titanlegierungen	< 1200 N/mm <sup>2</sup>	3.7164	TiAl5V4	3.7144	
H	Stahl gehärtet	< 45 HRc			
		46-55HRc			
		56-60 HRc			
		61-65 HRc			
	65-70 HRc				



# SYSTEM DED / ZTP

Einstecken mit  
zwei- und dreischneidigen  
Wendepplatten

grooving with  
two and three-cutting edges  
indexable inserts

# Technische Hinweise

Schnittdaten

Technical instructions,  
cutting data



Werkstoffbezeichnung	Werkstoff-Nr	Werkstoffbezeichnung	Vc K10F (m/min.)	Vc AL41F (m/min.)	Vc CN45F (m/min.)	f DED (mm/U)	f ZTP (mm/U)
St52-3	1.0060	St60-2		80-200	100-220	0,03-0,1	0,05-0,2
45S20	1.0757	46SPb2		80-200	100-220	0,03-0,1	0,05-0,2
17Mn4	1.1141	C15E (CK15)		80-200	100-180	0,03-0,1	0,05-0,2
13Cr3 (EC60)	1.5919	15CrNi6		80-160	100-180	0,03-0,1	0,05-0,2
Ck45	1.0535	C55		80-160	80-140	0,03-0,1	0,05-0,2
Ck60	1.0540	C50		80-160	80-140	0,03-0,1	0,05-0,2
28Cr4	1.7225	42CrMo4		80-160	80-140	0,03-0,1	0,05-0,2
34Cr4	1.3565	48CrMo4		80-150	80-140	0,03-0,1	0,05-0,2
GS-20NiCrMo3 7	1.6582	GS-34 CrNiMo 6		80-200	100-180	0,03-0,1	0,05-0,2
34AlMo5	1.8509	41CrAlMo7		70-140	60-120	0,03-0,07	0,05-0,15
39CrMoV19 3	1.8550	34 CrAlNi 7		70-140	60-120	0,03-0,07	0,05-0,15
X192CrMo17	1.3520	100 CrMn 6 (W4)		70-140	60-120	0,03-0,07	0,05-0,15
55Cr3	1.7701	51CrMoV4		40-60		0,03-0,07	0,05-0,15
S 18-1-2-5	1.3294	PMH56-5-3-8; ASP30		40-60		0,03-0,07	0,05-0,15
X155CrVMo12 1	1.2316	X38CrMo16; RAMAX		40-60		0,03-0,07	0,05-0,15
X45NiCrMo4	1.2842	90MnCrV8		40-60		0,03-0,07	0,05-0,15
X4CrMoS18	1.4107	GX8CrNi12	40-80	80-160	80-160	0,02-0,06	0,03-0,1
X105CrCoMo18 2	1.4016	X6Cr17	40-80	80-160	80-160	0,02-0,06	0,03-0,1
X50CrMoV15	1.4106	X2CrMoSiS18-2-1	40-80	80-160	80-160	0,02-0,06	0,03-0,1
X30Cr13	1.4104	X14CrMoS17	30-65	20-85	20-90	0,02-0,06	0,03-0,1
X20CrNiSi25 4	1.4462	X2CrNiMoN22-5-3 (Duplex)	30-65	20-75	20-90	0,02-0,06	0,03-0,1
X6CrNiMoTi17 12 2	1.4449	X3CrNiMo18-12-3	30-65	20-65	20-90	0,02-0,06	0,03-0,1
X10NiCrAlTi32-21	1.4825	GX25CrNiSi18-9	30-65	20-65	20-90	0,02-0,06	0,03-0,01
GG25			30-110	30-180	30-160	0,03-0,1	0,05-0,2
GG45			30-90	30-150	30-140	0,03-0,1	0,05-0,2
GGG50			25-110	30-180	30-160	0,03-0,1	0,05-0,2
GGG80			25-80	30-120	30-100	0,03-0,1	0,05-0,2
GTW45			20-40	30-90	30-80	0,03-0,1	0,05-0,2
GTW65			20-40	20-80	20-70	0,03-0,1	0,05-0,2
GTS45			20-40	30-90	30-80	0,03-0,1	0,05-0,2
GTS70			20-40	20-80	20-70	0,03-0,1	0,05-0,2
Al99,9Mg0,5	3.0256	E-Al H	120-500	120-600		0,05-0,12	0,08-0,25
AlCuMg2	3.3315	AlMg1	120-500	120-600		0,05-0,12	0,08-0,25
GD-ALSi9Mg	3.2134	GD-ALSi5Cu1Mg	100-400	100-450		0,05-0,12	0,08-0,25
G-MgAl6	3.2525	S-ALSi12	70-250	70-300		0,05-0,12	0,08-0,25
G-ALSi25CuNiMg		G-ALSi21CuNiMg	60-140	60-150		0,05-0,12	0,08-0,25
SF-Cu	2.1522	CuSi2Mn	60-140	60-150		0,05-0,12	0,08-0,25
CuZn30	2.0321	CuZn37	100-160	100-180		0,05-0,12	0,08-0,25
CuSi3Mn		Ampco 8-16	90-160	90-180		0,05-0,12	0,08-0,25
		Ampco 18-26	80-160	80-180		0,05-0,12	0,08-0,25
		Ampco M-4	80-160	80-180		0,05-0,12	0,08-0,25
CuZn39Pb2 (Ms58)	2.0410	CuZn44Pb2	120-200	120-220		0,05-0,12	0,08-0,25
CuCrZr	2.1080	CuSn6Zn6	70-140	70-150		0,05-0,12	0,08-0,25
Makrolon, Novodur		Acrylglas, Polystyrol	80-160	80-180		0,05-0,12	0,08-0,25
Pertinax		Resopal	80-160	80-180		0,05-0,12	0,08-0,25
CFK (Kohlefaserverstärkt)		AFK (Amidfaserverstärkt)		80-180		0,05-0,12	0,08-0,25
MgAl6Zn1	3.5812	MgAl8Zn1		80-180		0,05-0,12	0,08-0,25
R8650		Technograph15		80-180		0,05-0,12	0,08-0,25
W-Cu80/20		W93NiFe (DENAL)		80-180		0,05-0,12	0,08-0,25
TZC, TZM		MHC, ODS		80-180		0,05-0,12	0,08-0,25
RNi8	1.3926	RNi12		30-80		0,01-0,04	0,02-0,07
Ni54	1.3921	Ni49		18-75		0,01-0,04	0,02-0,07
NiCu 30 Fe		Monel 400		18-75		0,01-0,04	0,02-0,07
NiMo16Cr16Ti		Hastelloy C-276		18-40		0,01-0,04	0,02-0,07
NiCr20TiAl		Nimonic 80		18-40		0,01-0,04	0,02-0,07
NiCr19Co14Mo4Ti		Waspaloy		18-40		0,01-0,04	0,02-0,07
X12CrNiMo12	1.4980	X6NiCrTiMoVB25-15-2		15-30		0,01-0,04	0,02-0,07
NiCr23Fe, Inconel 601	2.4667	SG-NiCr19NbMoTi		15-30		0,01-0,04	0,02-0,07
Ti99,7	3.7064	Ti99,5		15-30		0,01-0,04	0,02-0,07
TiAl6V6Sn2	3.7124	TiCu2		100-150		0,01-0,04	0,02-0,07
TiAl6Sn2Zr4Mo2	3.7154	TiAl6Zr5		100-150		0,01-0,04	0,02-0,07

f: (mm/U)  $\cong$  (mm/Rev.)







 **Dümmel**<sup>®</sup>  
WERKZEUGFABRIK

## NUTSTOSSEN



Herstellung von Längsnuten Breite 2-20 mm  
und Innensechskant

Broaching keyways in the range of 2-20 mm  
and hexagon socket

## NUTSTOSEN

von Längsnuten nach  
DIN 138 und DIN 6885

broaching keyways according  
DIN 138 und DIN 6885

## Übersicht

summary



Allgemeine Beschreibung

general instructions

... 282

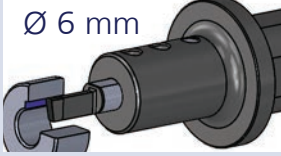
 Ø 6 mm	<b>Nutstossen ab D min. 6 mm</b>	<b>broaching keyways starting D min. 6 mm</b>	<b>Maße dimensions</b>	<b>Seite page</b>
	<b>Klemmhalter Typ NHU und Schneideinsatz Typ NPU</b>	<b>toolholder type NHU and insert type NPU</b>		

<b>Typ NHU</b>	Klemmhalter	toolholder	D min. 6	... 283
<b>Typ NPU</b>	Schneideinsatz Toleranzklasse C11 / JS9 / P9 / H9	insert tolerance grade C11 / JS9 / P9 / H9	D min. 6 - 7 B = 2 - 5	... 284
<b>Typ NPU. ...45</b>	Schneideinsatz Fasen 45°	insert chamfering 45°	D min. 9	... 286

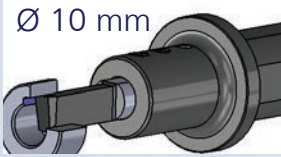
 Ø 10 mm	<b>Nutstossen D min. 10 mm</b>	<b>broaching keyways D min. 10 mm</b>	<b>Maße dimensions</b>	<b>Seite page</b>
	<b>Klemmhalter Typ NH10 und Schneideinsatz Typ NP10</b>	<b>toolholder type NH10 and insert type NP10</b>		

<b>Typ NH10</b>	Klemmhalter	toolholder	D min. 10	... 287
<b>Typ NP10</b>	Schneideinsatz Toleranzklasse C11 / JS9 / P9 / H9	insert tolerance grade C11 / JS9 / P9 / H9	D min. 10 B = 3 - 6	... 288

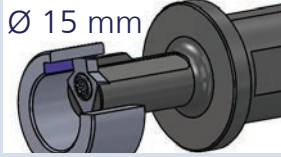
 Ø 15 mm	<b>Nutstossen D min. 15 mm</b>	<b>broaching keyways D min. 15 mm</b>	<b>Maße dimensions</b>	<b>Seite page</b>
	<b>Klemmhalter Typ NHV.15 und Schneideinsatz Typ NV15</b>	<b>toolholder type NHV.15 and insert type NV15</b>		

<b>Typ NHV.15.IK25</b>	Klemmhalter mit Innenkühlung	toolholder with internal cooling	D min. 15	... 290
<b>Typ NHV.15</b>	Klemmhalter für angetriebene Stosswerkzeuge	toolholder for driven slotting tool	D min. 15	... 291
<b>Typ NV15</b>	Schneideinsatz Nuttiefe bis 3.3 mm Toleranzklasse C11 / JS9 / P9 / inch	insert depth of groove up to 3.3 tolerance grade C11 / JS9 / P9 / inch	D min. 15 B = 4 - 6	... 292
<b>Typ NV15. ...45</b>	Schneideinsatz Fasen 45°	insert chamfering 45°	D min. 15 B = 5 - 8	... 298

## NUTSTOSSEN

von Längsnuten nach  
DIN 138 und DIN 6885

broaching keyways according  
DIN 138 und DIN 6885

## Übersicht

summary

 <p>Ø 22 mm</p>	<p><b>Nutstossen</b> ab D min. 22 mm</p> <p><b>Klemmhalter Typ NHV und</b> <b>Schneideinsatz Typ NPV</b></p>	<p><b>broaching keyways</b> starting D min. 22 mm</p> <p><b>toolholder type NHV and</b> <b>insert type NPV</b></p>	<p><b>Maße</b> <b>dimensions</b></p>	<p><b>Seite</b> <b>page</b></p>
<p><b>Typ NHV.22</b> <b>Typ NHV.30</b> <b>Typ NHV.38</b> <b>Typ NHV.45</b></p>	<p>Klemmhalter</p>	<p>toolholder</p>	<p>D min. 22 D min. 30 D min. 38 D min. 45</p>	<p>... <b>293</b></p>
<p><b>Typ NHV.22</b> <b>Typ NHV.30</b></p>	<p>Klemmhalter für angetriebene Stosswerkzeuge</p>	<p>toolholder for driven slotting tool</p>	<p>D min. 22 D min. 30</p>	<p>... <b>294</b></p>
<p><b>Typ NPV</b></p>	<p>Schneideinsatz Nuttiefe bis 10 mm Toleranzklasse C11 / JS9 / P9 / H9 / inch</p>	<p>insert depth of groove up to 10 tolerance grade C11 / JS9 / P9 / H9 / inch</p>	<p>D min. 22 - 45 B = 5 - 20</p>	<p>... <b>295</b></p>
<p><b>Typ NPV. ...45</b></p>	<p>Schneideinsatz Fasen 45°</p>	<p>insert chamfering 45°</p>	<p>D min. 22 / 38 B = 6 - 12</p>	<p>... <b>298</b></p>
 <p>SW 2.5-16</p>	<p><b>Nutstossen</b> Schlüsselweite 2.5 - 16</p> <p><b>Schneideinsatz</b> <b>Typ NPU.SW / NP10.SW</b></p>	<p><b>broaching keyways</b> wrench size 2.5 - 16</p> <p><b>insert</b> <b>type NPU.SW / NP10.SW</b></p>	<p><b>Maße</b> <b>dimensions</b></p>	<p><b>Seite</b> <b>page</b></p>
<p><b>Typ NPU.SW</b></p>	<p>Schneideinsatz für Innensechskant</p>	<p>insert for hexagon socket</p>	<p>SW 2.5 - 8</p>	<p>... <b>299</b></p>
<p><b>Typ NP10.SW</b></p>	<p>Schneideinsatz für Innensechskant</p>	<p>insert for hexagon socket</p>	<p>SW 10 - 16</p>	<p>... <b>300</b></p>



## NUTSTOSSEN

von Längsnuten nach  
DIN 138 und DIN 6885

broaching keyways according  
DIN 138 und DIN 6885

## Übersicht

summary



### Sets Nutstossen

### sets broaching keyways

### Maße dimensions

### Seite page

### Halter und Schneiden

### toolholder and inserts

#### SET - NPU

Auswahl  
Toleranzklasse JS9

selection  
tolerance grade JS9

D min. 6  
B = 2 / 3 / 4

... 301

#### SET - NP10

Auswahl  
Toleranzklasse JS9

selection  
tolerance grade JS9

D min. 10  
B = 4 / 5

... 301

#### SET - NPV

Auswahl  
Toleranzklasse JS9

selection  
tolerance grade JS9

D min. 22 / 30  
B = 5.01 / 6.01  
/ 8.01

... 302

### Technische Hinweise

### Technical Instructions

### Seite page

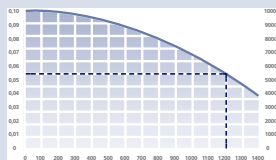

Grundsätzliche Informationen zum  
Nutstossen

Basic informations about  
broaching keyways

... 303

Hartmetallsorten und Beschichtungen

carbide grades and coatings

... 305

Schnittdaten

cutting data

... 307

## NUTSTOSEN

von Längsnuten nach  
DIN 138 und DIN 6885

broaching keyways according  
DIN 138 und DIN 6885

## Allgemeine Beschreibung

Stossen von Innennuten  
auf CNC-Maschinen

general instructions,  
broaching keyways  
on CNC machines

Komplettbearbeitung auf CNC-Drehmaschinen  
und Fräszentren ohne Umspannen.  
Einfach und wirtschaftlich.

Complete machining on CNC turning- and milling centres  
in one clamping. Simple and efficient.





## NUTSTOSEN

von Längsnuten nach  
DIN 138 und DIN 6885

broaching keyways according  
DIN 138 und DIN 6885

## Typ NHU

Klemmhalter

D min. 6 mm

toolholder

D min. 6 mm

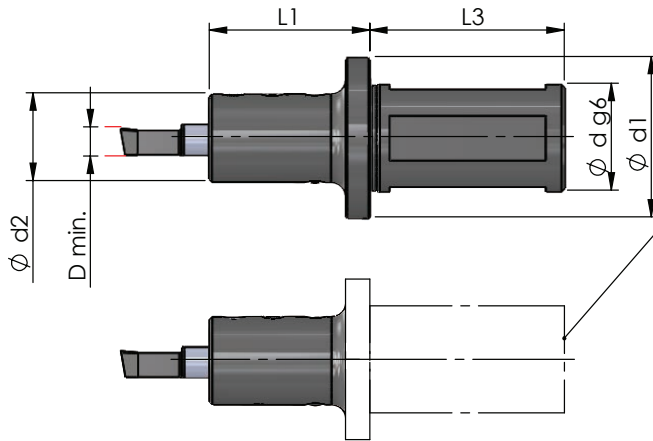

Aufnahme nach Herstellerangaben  
clamping part according to  
manufacturer's specification

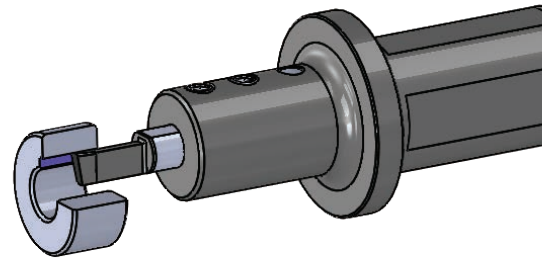

Abmessungen in mm

dimensions in mm



Bestellnummer part number	D min.	Ø d g6 x L3 Aufnahme clamping part	Ø d (inch)	L1	Ø d1	Ø d2		Spannschraube screw	Schrauben- schlüssel wrench	Anzugs- drehmoment torque	für Schneid- platte for insert
NHU.0020.1	6	Ø20 x 40		33	33	18					
NHU.0022.1	6	Ø22 x 40		33	33	18					
NHU.0025.1	6	Ø25 x 40		33	33	18		110.645	111.645	1.5 Nm	NPU,...
NHU.00254.1	6	Ø25.4 x 40	1"	33	33	18					
NHU.0032.1	6	Ø32 x 40		33	40	20		110.650	111.645	1.5 Nm	
Bestellnummer part number	D min.	Aufnahme nach Herstellerangabe clamping part acc. to manufac. specification		L1	Ø d2		für Nutstoss- geräte for broaching device	Spannschraube screw	Schrauben- schlüssel wrench	Anzugs- drehmoment torque	für Schneid- platte for insert
NHU.0012.1	6	Ø12 x 25		32	20		Schwarzer 1				
NHU.0015.1	6	Ø15 x 33		37	18		Schwarzer 2 in 1				
NHU.0016.1	6	Ø16 x 30		33	18		EWS Slot + Benz LinA				
NHU.MP16.1	6	Ø16 x 34		33	18		Mario Pinto Stoßeinheit	110.645	111.645	1.5 Nm	NPU,...
NHU.MT16.1	6	Ø16 x 25		33	18		MT Marchetti				
NHU.WT16.1	6	Ø16 x 6		36	18		WTO Stoßeinheit				

Bestellbeispiel:  
NHU.0020.1

order example:  
NHU.0020.1



# NUTSTOSSEN

von Längsnuten nach  
DIN 138 und DIN 6885

broaching keyways according  
DIN 138 und DIN 6885

# Typ NPU

Schneideinsatz

D min. 6 - 7 mm  
Toleranzklasse C11 / JS9 / P9 / H9

insert

D min. 6 - 7 mm  
tolerance grade C11 / JS9 / P9 / H9

NPU.0... ..

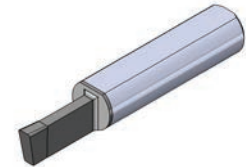
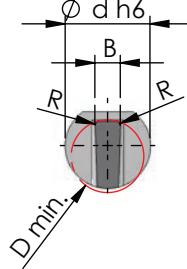
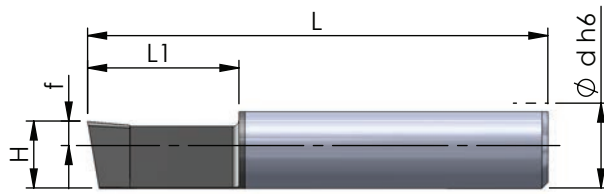

NPU.0298.01.2 / NPU.0300.01.2

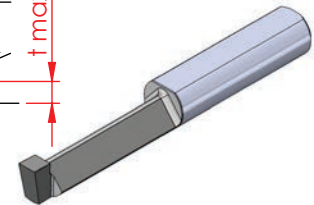
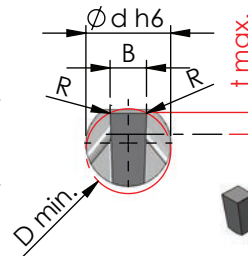
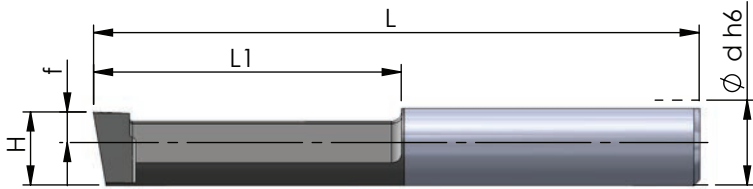

Abmessungen in mm

dimensions in mm

Bestellnummer part number	Abmessungen in mm									dimensions in mm			Schneideinsatz nach DIN	insert according DIN	K10F AL41F P18C	für Klemhalter for toolholder type
	D min.	B	R	H +0.05	f	L	L1	Ø d h6	t max.							
NPU.0210.03.1	6	2.1	0.35	5.5	2.0	38	12.5	7	-						NHU...	
NPU.0310.03.1	7	3.1	0.35	6.2	2.7	38	12.5	7	-	C11						
NPU.0310.05.1	7	3.1	0.5	6.2	2.7	38	12.5	7	-	DIN 138						
NPU.0410.05.1	7	4.1	0.5	6.2	2.7	40	15	7	-	Standard						
NPU.0410.05.2	7	4.1	0.5	6.2	2.7	50	25	7	-							
NPU.0200.01.1	6	2.00	0.1	5.5	2.0	38	12.5	7	-							
NPU.0300.01.1	7	3.00	0.1	6.2	2.7	38	12.5	7	-							
NPU.0300.01.2	7	3.00	0.1	6.0	2,5	50	25	7	1.8	JS9						
NPU.0400.01.1	7	4.00	0.1	6.2	2.7	40	15	7	-	DIN 6885						
NPU.0400.02.1	7	4.00	0.2	6.2	2.7	40	15	7	-	leichter Sitz						
NPU.0400.02.2	7	4.00	0.2	6.2	2.7	50	25	7	-	slightly fit						
NPU.0500.02.2	7	5.00	0.2	5.8	2.3	50	25	7	-							

↳ ...

Weitere HM Sorten können Sie in der Sortenübersicht im Kapitel "Technische Hinweise" und der Preisliste finden.

Bestellbeispiel:  
für Sorte AL41F:  
NPU.0210.03.1/AL41F

More carbide grades you can find in the grades summary in the chapter "technical instructions" and in the price list.

order example:  
grade AL41F:  
NPU.0210.03.1/AL41F

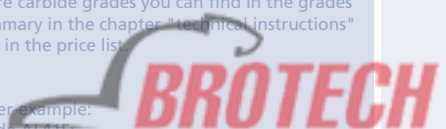

## NUTSTOSSEN

von Längsnuten nach  
DIN 138 und DIN 6885

broaching keyways according  
DIN 138 und DIN 6885

## Typ NPU

Schneideinsatz

D min. 6 - 7 mm  
Toleranzklasse C11 / JS9 / P9 / H9

insert

D min. 6 - 7 mm  
tolerance grade C11 / JS9 / P9 / H9

NPU.0... ..

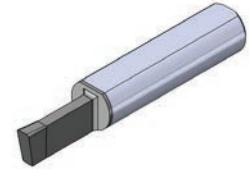
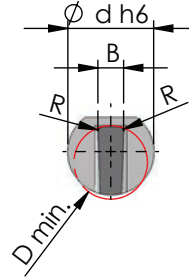
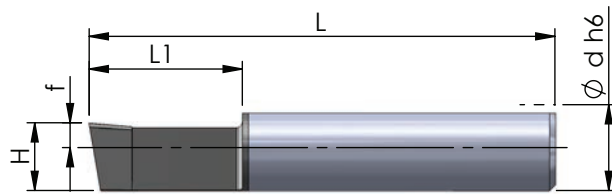

NPU.0298.01.2 / NPU.0300.01.2

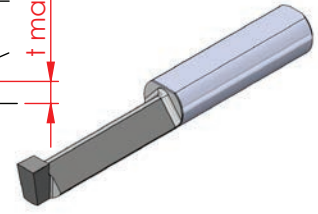
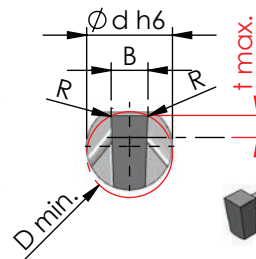
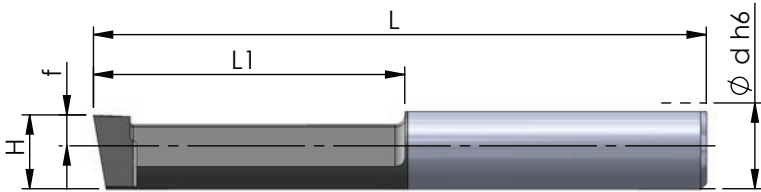

Abmessungen in mm

dimensions in mm



Bestellnummer part number	D min.	B	R	H +0.05	f	L	L1	Ø d h6	t max.	Schneideinsatz nach DIN	insert according DIN	K10F	AL41F	P18C	für Klemhalter for toolholder type
NPU.0198.01.1	6	1.98	0.1	5.5	2.0	38	12.5	7	-			●			NHU,...
NPU.0298.01.1	7	2.98	0.1	6.2	2.7	38	12.5	7	-	p9		●			
NPU.0298.01.2	7	2.98	0.1	6.0	2.5	50	25	7	1.8	DIN 6885		●			
NPU.0398.01.1	7	3.98	0.1	6.2	2.7	40	15	7	-	fester Sitz		●			
NPU.0398.02.2	7	3.98	0.2	6.2	2.7	50	25	7	-	strong fit		●			
NPU.0498.02.2	7	4.98	0.2	5.8	2.3	50	25	7	-			●			
NPU.020H.01.1	6	2.02	0.1	5.5	2.0	38	12.5	7	-			●			
NPU.030H.01.1	7	3.02	0.1	6.2	2.7	38	12.5	7	-			●			
NPU.040H.01.1	7	4.02	0.1	6.2	2.7	40	15	7	-			●			
NPU.040H.02.2	7	4.02	0.2	6.2	2.7	50	25	7	-	H9		●			
NPU.050H.02.2	7	5.02	0.2	5.8	2.3	50	25	7	-	DIN 6885		●			

Weitere HM Sorten können Sie in der Sortenübersicht im Kapitel "Technische Hinweise" und der Preisliste finden.

Bestellbeispiel:  
für Sorte AL41F:  
NPU.0198.01.1/AL41F

More carbide grades you can find in the grades summary in the chapter "technical instructions" and in the price list.

order example:  
grade AL41F:  
NPU.0198.01.1/AL41F



# NUTSTOSSEN

von Längsnuten nach  
DIN 138 und DIN 6885

broaching keyways according  
DIN 138 und DIN 6885

# Typ NPU. ... 45

Schneideinsatz  
Fasen 45°

D min. 9 mm

insert  
chamfering 45°

D min. 9 mm

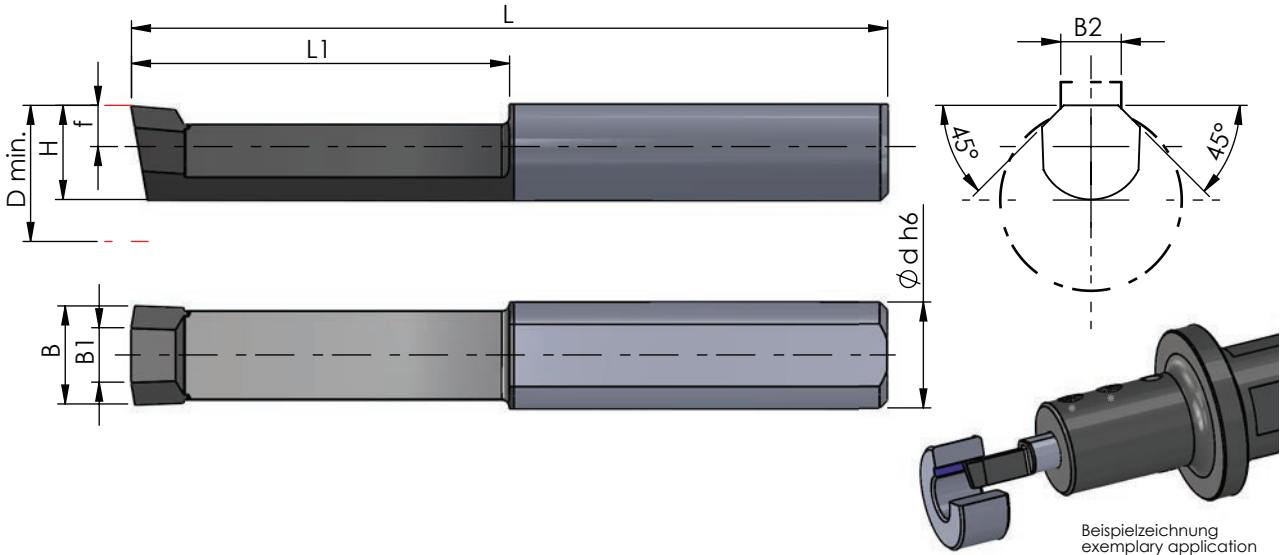

Abmessungen in mm

dimensions in mm

Bestellnummer part number	D min.	B	B1	B2 Nutenbreite width of groove	H +0.05	f	L	L1	Ø d h6	Klemmhalter			für Klemmhalter for toolholder type
										K10F	AL41F	P18C	
NPU.4545.1	9	6.5	3.6	4 - 5	6.2	2.7	50	25	7	●			NHU...



Weitere HM Sorten können Sie in der Sortenübersicht im Kapitel "Technische Hinweise" und der Preisliste finden.

Bestellbeispiel:  
für Sorte AL41F:  
NPU.4545.1/AL41F

More carbide grades you can find in the grades summary in the chapter "technical instructions" and in the price list.

order example:  
grade AL41F:  
NPU.4545.1/AL41F



## NUTSTOSEN

von Längsnuten nach  
DIN 138 und DIN 6885

broaching keyways according  
DIN 138 und DIN 6885

## Typ NH10

Klemmhalter

D min. 10 mm

toolholder

D min. 10 mm

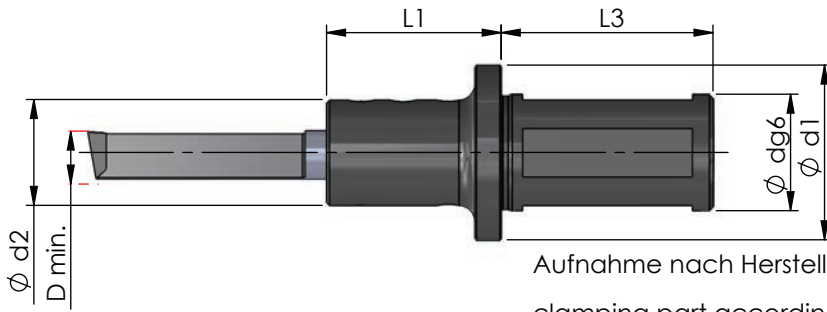

Aufnahme nach Herstellerangaben

clamping part according to  
manufacturer's specification

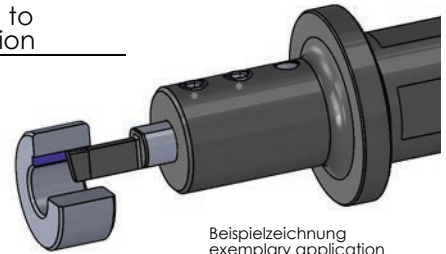

Beispielzeichnung  
exemplary application

Abmessungen in mm

dimensions in mm



Bestellnummer part number	D min.	Ø d g6 x L3 Aufnahme clamping part	L1	Ø d1	Ø d2	Spannschraube screw	Schraubenschlüssel wrench	Anzugs- drehmoment torque	für Schneidplatte for insert
NH10.0020.1	10	Ø20 x 40	33	33	20				
NH10.0022.1	10	Ø22 x 40	33	33	20				
NH10.0025.1	10	Ø25 x 40	33	33	20	110.660	111.687	2.5 Nm	NP10,...
NH10.0032.1	10	Ø32 x 40	33	40	20				

Bestellnummer part number	D min.	Aufnahme nach Herstellerangabe clamping part acc. to manufac. specification	Ø d2	für Nutstossergeräte for broaching device	Spannschraube screw	Schraubenschlüssel wrench	Anzugs- drehmoment torque	für Schneidplatte for insert
NH10.0012.1	10	Ø12 x 25	32	Schwarzer 1				
NH10.0015.1	10	Ø15 x 33	37	Schwarzer 2 in 1				
NH10.0016.1	10	Ø16 x 30	33	EWS Slot + Benz LinA				
NH10.MP16.1	10	Ø16 x 34	33	Mario Pinto Stoßeinheit	110.660	111.687	2.5 Nm	NP10,...
NH10.MT16.1	10	Ø16 x 25	33	MT Marchetti				
NH10.WT16.1	10	Ø16 x 6	36	WTO Stoßeinheit				

Bestellbeispiel:  
NH10.0020.1

order-example:  
NH10.0020.1



# NUTSTOSEN

von Längsnuten nach  
DIN 138 und DIN 6885

broaching keyways according  
DIN 138 und DIN 6885

# Typ NP10

Schneideinsatz

D min. 10 mm  
Toleranzklasse C11 / JS9 / P9 / H9

insert

D min. 10 mm  
tolerance grade C11 / JS9 / P9 / H9

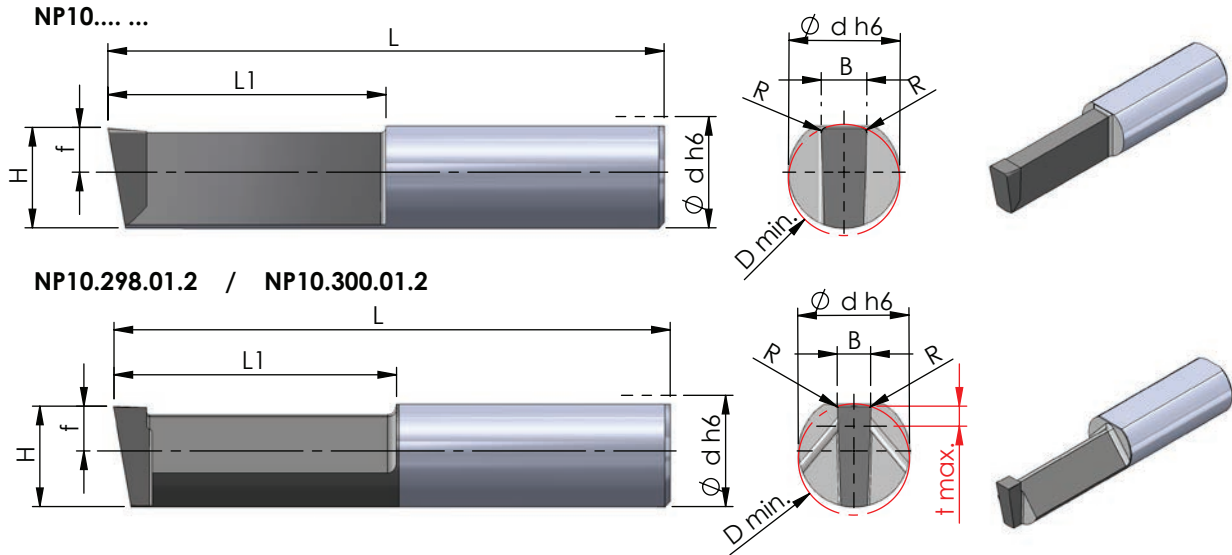

Abmessungen in mm

dimensions in mm

Bestellnummer part number	Abmessungen in mm										Schneideinsatz nach DIN	insert according DIN	K10F AL41F P18C	für Klemhalter for toolholder type
	D min.	B	R	H +0.05	f	L	L1	Ø d h6	t max.					
NP10.410.05.2	10	4.1	0.5	9	4	50	25	10	-		C11 DIN 138		●	NH10...
NP10.410.05.3	10	4.1	0.5	9	4	66	41	10	-					
NP10.510.05.2	10	5.1	0.5	9	4	50	25	10	-		Standard	●		
NP10.510.05.3	10	5.1	0.5	9	4	66	41	10	-					
NP10.300.01.2	10	3.0	0.1	9	4	50	25	10	1.8		JS9 DIN 6885	●		
NP10.400.02.2	10	4.0	0.2	9	4	50	25	10	-					
NP10.400.02.3	10	4.0	0.2	9	4	66	41	10	-		leichter Sitz slightly fit	●		
NP10.500.02.2	10	5.0	0.2	9	4	50	25	10	-					
NP10.500.02.3	10	5.0	0.2	9	4	66	41	10	-		●			
NP10.600.02.3	10	6.0	0.2	8.5	3.5	66	41	10	-					
↳ ...														

Weitere HM Sorten können Sie in der Sortenübersicht im Kapitel "Technische Hinweise" und der Preisliste finden.

Bestellbeispiel:  
für Sorte AL41F:  
NP10.410.05.2/AL41F

More carbide grades you can find in the grades summary in the chapter "technical instructions" and in the price list.

order example:  
grade AL41F:  
NP10.410.05.2/AL41F



## NUTSTOSSEN

von Längsnuten nach  
DIN 138 und DIN 6885

broaching keyways according  
DIN 138 und DIN 6885

## Typ NP10

Schneideinsatz

D min. 10 mm  
Toleranzklasse C11 / JS9 / P9 / H9

insert

D min. 10 mm  
tolerance grade C11 / JS9 / P9 / H9

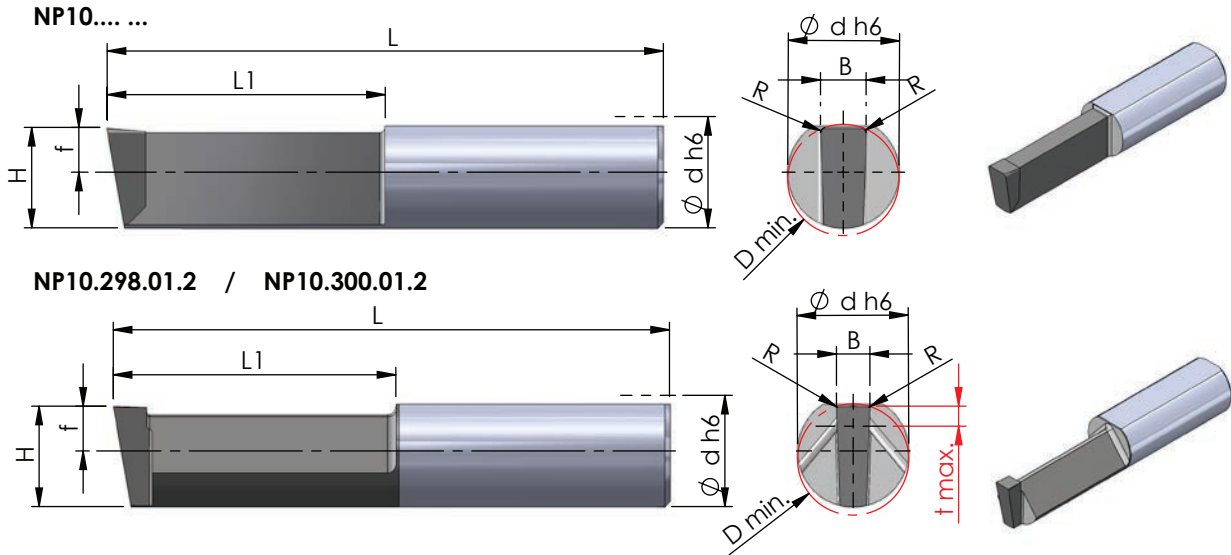

Abmessungen in mm

dimensions in mm



Bestellnummer part number	D min.	B	R	H +0.05	f	L	L1	Ø d h6	t max.	Schneideinsatz nach DIN	insert according DIN	K10F	AL41F	P18C	für Klemhalter for toolholder type
NP10.298.01.2	10	2.98	0.1	9	4	50	25	10	1.8						NH10...
NP10.398.02.2	10	3.98	0.2	9	4	50	25	10	-	p9					
NP10.398.02.3	10	3.98	0.2	9	4	66	41	10	-	DIN 6885					
NP10.498.02.2	10	4.98	0.2	9	4	50	25	10	-	fester Sitz					
NP10.498.02.3	10	4.98	0.2	9	4	66	41	10	-	strong fit					
NP10.598.02.3	10	5.98	0.2	8.5	3.5	66	41	10	-						
NP10.040H.02.2	10	4.02	0.2	9	4	50	25	10	-						
NP10.040H.02.3	10	4.02	0.2	9	4	66	41	10	-						
NP10.050H.02.2	10	5.02	0.2	9	4	50	25	10	-	H9					
NP10.050H.02.3	10	5.02	0.2	9	4	66	41	10	-	DIN 6885					
NP10.060H.02.3	10	6.05	0.2	8.5	3.5	66	41	10	-						

Weitere HM Sorten können Sie in der Sortenübersicht im Kapitel "Technische Hinweise" und der Preisliste finden.

Bestellbeispiel:  
für Sorte AL41F:  
NP10.298.01.2/AL41F

More carbide grades you can find in the grades summary in the chapter "technical instructions" and in the price list.

order example:  
grade AL41F:  
NP10.298.01.2/AL41F

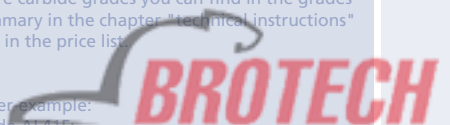

## NUTSTOSEN

von Längsnuten nach  
DIN 138 und DIN 6885

broaching keyways according  
DIN 138 und DIN 6885

## Typ NHV.15.IK25

Klemmhalter  
mit Innenkühlung

toolholder  
with internal cooling

D min. 15 mm

D min. 15 mm

innere Kühlmittelzufuhr  
through coolant

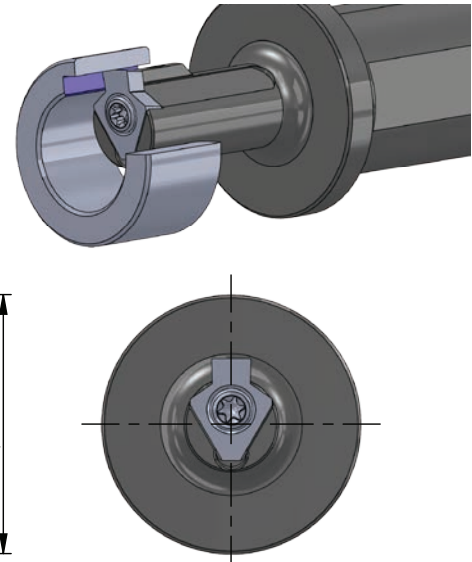
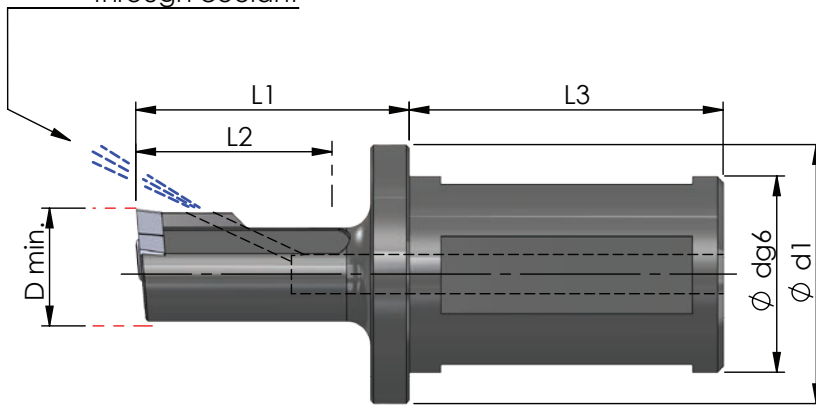

Abmessungen in mm

dimensions in mm

Bestellnummer part number	D min.	Ø d g6 x L3 Aufnahme clamping part	L1	L2	Ø d1	Spannschraube screw	Schraubenschlüssel wrench	Anzugs- drehmoment torque	für Schneidplatte for insert
NHV.15.IK25.1	15	Ø25 x 40	35	25	33	M4-NH15	Torx TR15	4.0 Nm	NV15...
NHV.15.IK25.2	15	Ø25 x 40	50	40	33				
NHV.15.IK25.3	15	Ø25 x 40	70	60	33				



Bestellbeispiel:  
NHV.15.IK25.1



## NUTSTOSEN

von Längsnuten nach  
DIN 138 und DIN 6885

broaching keyways according  
DIN 138 und DIN 6885

## Typ NHV.15

Klemmhalter  
für angetriebene Stosswerkzeuge

D min. 15 mm

toolholder  
for driven slotting tool

D min. 15 mm

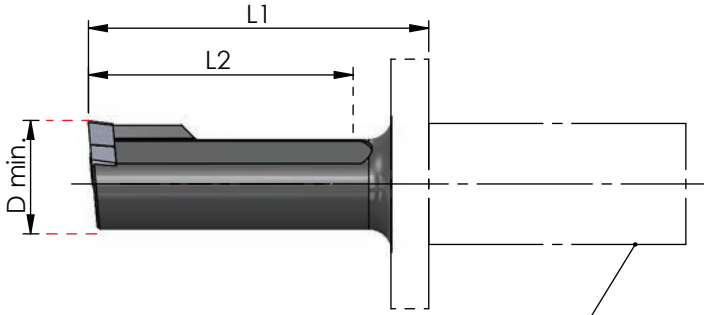

Aufnahme nach Herstellerangaben  
clamping part according to  
manufacture's specification

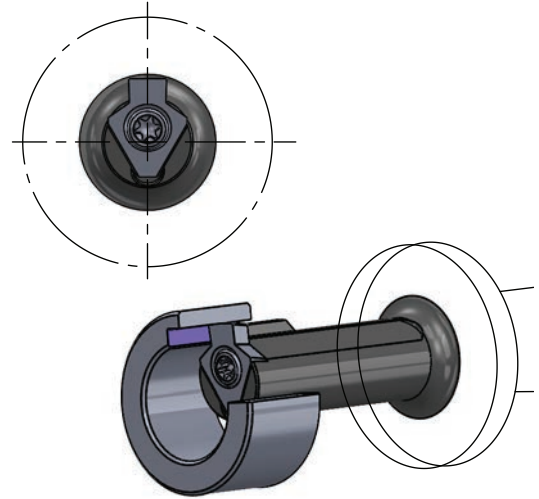

Abmessungen in mm

dimensions in mm



Bestellnummer part number	D min.	Aufnahme nach Herstellerangabe clamping part acc. to manufac. specification	L1	L2	für Nutstossergeräte for broaching device	Spannschraube screw	Schraubenschlüssel wrench	Anzugs- drehmoment torque	für Schneidplatte for insert
NHV.15.0012.1	15	Ø12 x 25	40	36	Schwarzer 1	M4-NH15	Torx TR15	4 Nm	NV15...
NHV.15.0015.1	15	Ø15 x 33	45	36	Schwarzer 2 in 1				
NHV.15.0015.2	15	Ø15 x 30	58	42	Schwarzer 2 in 1				
NHV.15.0016.1	15	Ø16 x 30	46	36	EWS Slot + Benz LinA				
NHV.15.MP16.1	15	Ø16 x 34	45	35	Mario Pinto Stoßeinheit				
NHV.15.MP16.2	15	Ø16 x 34	75	65	Mario Pinto Stoßeinheit				
NHV.15.MT16.1	15	Ø16 x 25	50	40	MT Marchetti				
NHV.15.WT16.1	15	Ø16 x 6	49	35	WTO Stoßeinheit				

Bestellbeispiel:  
NHV.15.0012.1

order-example:  
NHV.15.0012.1

# NUTSTOSSEN

von Längsnuten nach  
DIN 138 und DIN 6885

broaching keyways according  
DIN 138 und DIN 6885

# Typ NV15

Schneideinsatz

insert

D min. 15 mm  
Nuttiefe bis 3.3  
Toleranzklasse C11 / JS9 / P9 / inch

D min. 15 mm  
depth of groove up to 3.3  
tolerance grade C11 / JS9 / P9 / inch

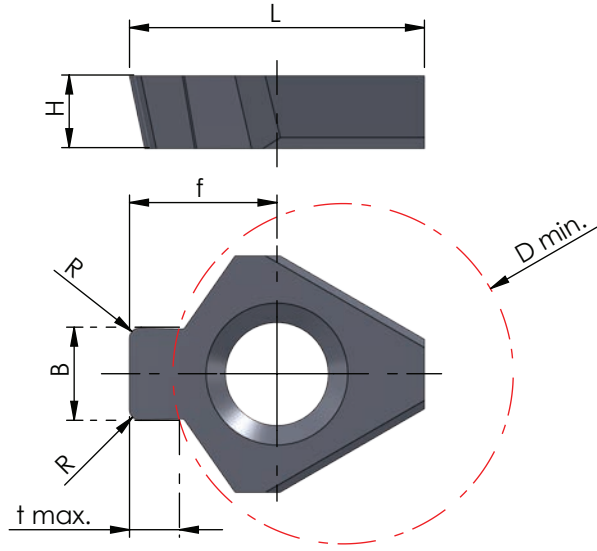

Beispielzeichnung  
exemplary application

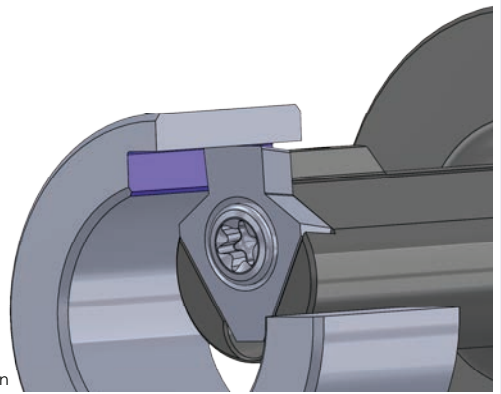

Abmessungen in mm

dimensions in mm

Bestellnummer part number	D min.	B	B (inch)	R	f	L	t max.	H	Schneideinsatz nach DIN	insert according DIN	für Klemhalter for toolholder type		
											K10F	AL41F	P18C
NV15.0410.050	15	4.10		0.50	6.5	13	2.2	3.2	C11 DIN 138 Standard	●	●	●	
NV15.0510.050	15	5.10		0.50	6.5	13	2.5	3.2					
NV15.0612.085	15	6.12		0.85	6.5	13	2.6	3.2					
NV15.0401.02	15	4.01		0.20	6.5	13	2.3	3.2	JS9 DIN 6885 leichter Sitz slightly fit	●	●	●	
NV15.0501.02	15	5.01		0.20	6.5	13	2.8	3.2					
NV15.0601.02	15	6.01		0.20	6.5	13	3.3	3.2					
NV15.0398.02	15	3.98		0.20	6.5	13	2.3	3.2	P9 DIN 6885 fester Sitz strong fit	●	●	●	
NV15.0498.02	15	4.98		0.20	6.5	13	2.8	3.2					
NV15.0598.02	15	5.98		0.20	6.5	13	3.3	3.2					
NV15.U0478.02	15	4.78	0.189"	0.20	6.5	13	2.8	3.2	inch	●	●	●	



Weitere HM Sorten können Sie in der Sortenübersicht im Kapitel "Technische Hinweise" und der Preisliste finden.

Bestellbeispiel:  
für Sorte AL41F:  
NV15.0410.050/AL41F

More carbide grades you can find in the grades summary in the chapter "technical instructions" and in the price list.

order example:  
grade AL41F:  
NV15.0410.050/AL41F



## NUTSTOSEN

von Längsnuten nach  
DIN 138 und DIN 6885

broaching keyways according  
DIN 138 und DIN 6885

## Typ NHV

Klemmhalter

D min. 22 / 30 / 38 / 45 mm

toolholder

D min. 22 / 30 / 38 / 45 mm

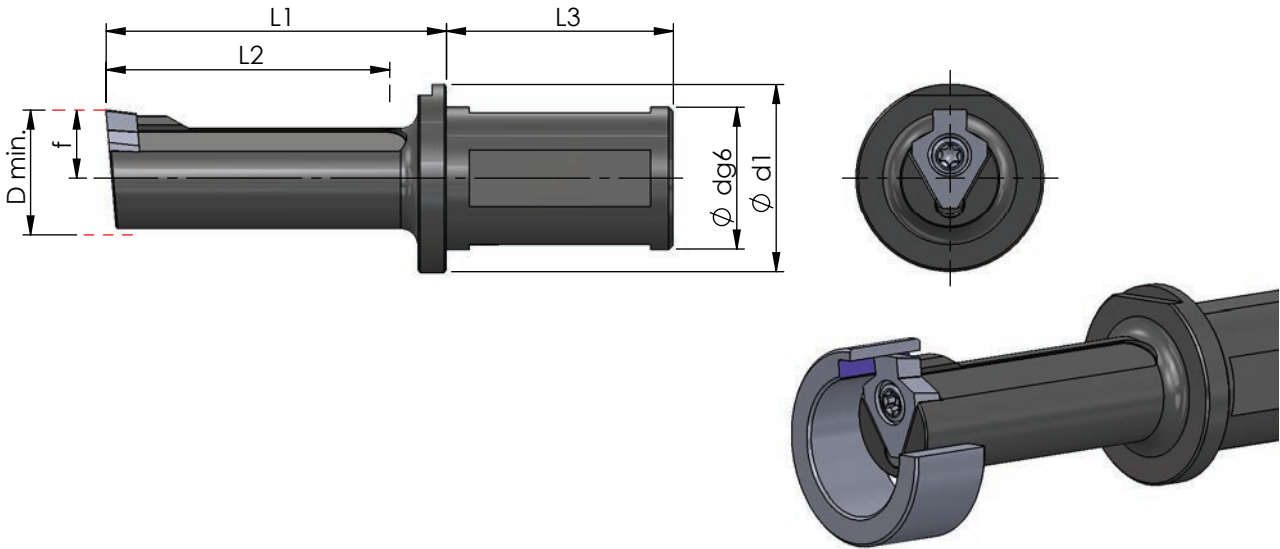

Abmessungen in mm

dimensions in mm



Bestellnummer part number	D min.	Ø d g6 x L3 Aufnahme clamping part	L1	L2	f	Ø d1	Spannschraube screw	Schraubenschlüssel wrench	Anzugs- drehmoment torque	für Schneidplatte for insert
NHV.22.0025.1	22	Ø25 x 40	60	50	12	33	85.818	Torx TX20	6.0 Nm	NPV...
NHV.22.0025.2	22	Ø25 x 40	85	75	12	33				
NHV.30.0032.1	30	Ø32 x 40	60	50	16.5	45				
NHV.30.0032.2	30	Ø32 x 40	85	75	16.5	45				
NHV.30.0032.3	30	Ø32 x 40	115	105	16.5	45				
NHV.38.0032.1	38	Ø32 x 40	60	50	22	45				
NHV.38.0032.2	38	Ø32 x 40	85	75	22	45				
NHV.38.0032.3	38	Ø32 x 40	115	105	22	45				
NHV.45.0040.1	45	Ø40 x 60	60	50	24	55				
NHV.45.0040.3	45	Ø40 x 60	115	105	24	55				
NHV.45.0040.4	45	Ø40 x 60	165	155	24	55				

Bestellbeispiel:  
NHV.22.0025.1

order-example:  
NHV.22.0025.1



## NUTSTOSEN

von Längsnuten nach  
DIN 138 und DIN 6885

broaching keyways according  
DIN 138 und DIN 6885

## Typ NHV

Klemmhalter  
für angetriebene Stosswerkzeuge

D min. 22 / 30 mm

toolholder  
for driven slotting tool

D min. 22 / 30 mm

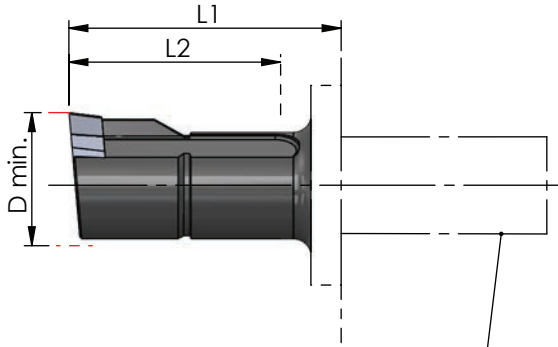

Aufnahme nach Herstellerangaben  
clamping part according to  
manufacturer's specification

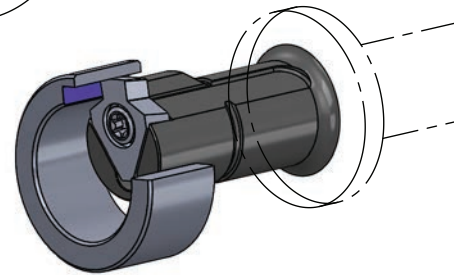
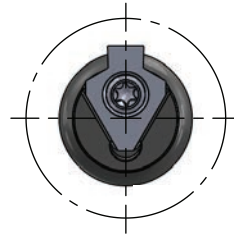

Abmessungen in mm

dimensions in mm

Bestellnummer part number	D min.	Aufnahme nach Herstellerangabe clamping part acc. to manufac. specification	L2		für Nutstosseräte for broaching device	Spannschraube screw	Schraubenschlüssel wrench	Anzugs- drehmoment torque	für Schneidplatte for insert
NHV.22.0012.1	22	Ø12 x 25	40	36	Schwarzer 1				
NHV.22.0015.1	22	Ø15 x 33	37	36	Schwarzer 2 in 1				
NHV.22.0015.2	22	Ø15 x 30	50	42	Schwarzer 2 in 1				
NHV.22.0016.1	22	Ø16 x 30	45	36	EWS Slot + Benz LinA				
NHV.22.0016.2	22	Ø16 x 30	65	55	EWS Slot + Benz LinA				
NHV.22.MP16.1	22	Ø16 x 34	45	35	Mario Pinto Stoßeinheit	85.818	Torx TX20	6 Nm	NPV....
NHV.22.MP16.2	22	Ø16 x 34	75	65	Mario Pinto Stoßeinheit				
NHV.22.MT16.1	22	Ø16 x 25	58	50	MT Marchetti				
NHV.22.WT16.1	22	Ø16 x 6	49	35	WTO Stoßeinheit				
NHV.30.0012.1	30	Ø12 x 25	40	36	Schwarzer 1				



Bestellbeispiel:  
NHV.22.0012.1

## NUTSTOSEN

von Längsnuten nach  
DIN 138 und DIN 6885

broaching keyways according  
DIN 138 und DIN 6885

## Typ NPV

Schneideinsatz  
Nuttiefe bis 10 mm,  
Toleranzklassen C11 / JS9 / P9 / H9 / inch

D min. 22 - 45 mm  
B = 5 - 20

insert  
depth of groove up to 10 mm,  
tolerance grade C11 / JS9 / P9 / H9 / inch

D min. 22 - 45 mm  
B = 5 - 20

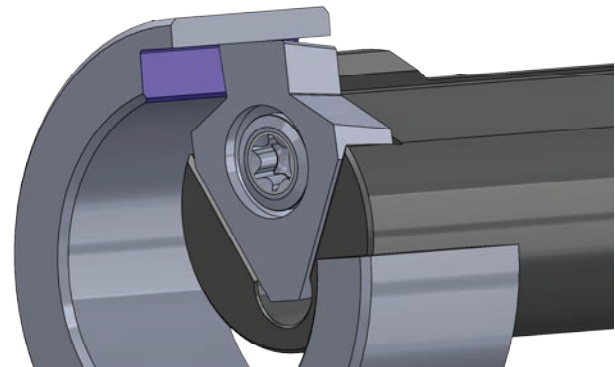
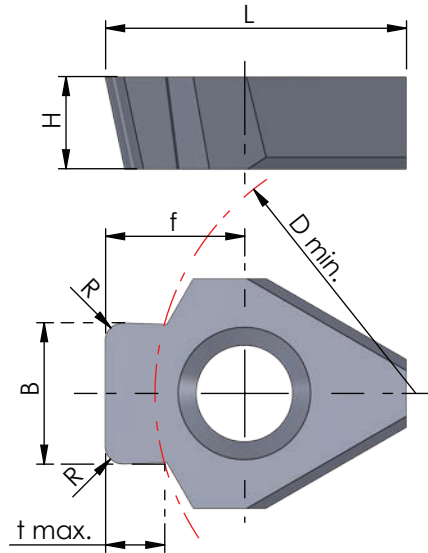

Abmessungen in mm

dimensions in mm



Bestellnummer part number	D min.	B	B (inch)	R	f	L	t max.	H	Schneideinsatz nach DIN	insert according DIN				für Klemmhalter for toolholder type
											K10F	AL41F	P18C	
NPV.0612.085	22	6.12		0.85	8	17.3	2.6	5.3	C11		●			NHV.22...
NPV.0713.085	22	7.13		0.85	8	17.3	3.3	5.3	DIN 138		●			NHV.22...
NPV.0813.105	30	8.13		1.05	8	17.3	3.4	5.3	Standard		●			NHV.30... (NHV.22)
NPV.0501.02	22	5.01		0.2	8	17.3	2.7	5.3	JS9		●			NHV.22...
NPV.0601.02	22	6.01		0.2	8	17.3	3.4	5.3	DIN 6885		●			NHV.22...
NPV.0801.02	30	8.01		0.2	8	17.3	4.1	5.3	leichter Sitz slightly fit		●			NHV.30... (NHV.22)
NPV.0498.02	22	4.98		0.2	8	17.3	2.7	5.3	P9		●			NHV.22...
NPV.0598.02	22	5.98		0.2	8	17.3	3.4	5.3	DIN 6885		●			NHV.22...
NPV.0798.02	30	7.98		0.2	8	17.3	4.1	5.3	fester Sitz strong fit		●			NHV.30... (NHV.22)
NPV.050H.02	22	5.02		0.2	8	17.3	2.7	5.3	H9		●			NHV.22...
NPV.060H.02	22	6.02		0.2	8	17.3	3.4	5.3	DIN 6885		●			NHV.22...
NPV.080H.02	30	8.02		0.2	8	17.3	4.1	5.3			●			NHV.30... (NHV.22)
neu NPV.U0638.02	22	6.38	0.251"	0.2	8	17.3	3.4	5.3	inch		●			NHV.22...
neu NPV.U0797.02	22	7.97	0.314"	0.2	8	17.3	4.1	5.3			●			NHV.22...
↳ ...														

Klemmhalter in Klammer sind nicht optimal in der Unterstützung. Schnittwerte reduzieren!  
Weitere HM Sorten können Sie in der Sortenübersicht im Kapitel "Technische Hinweise" und der Preisliste finden.  
Bestellbeispiel:  
für Sorte AL41F:  
NPV.0612.085/AL41F

Please note that toolholders in brackets are not the optimal choice. If using them, please reduce the cutting data!  
More carbide grades you can find in the grades summary in the chapter "Technical Instructions" and in the price list.  
order example:  
grade AL41F:  
NPV.0612.085/AL41F

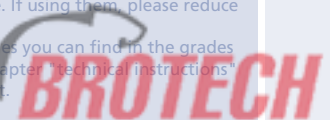

## NUTSTOSEN

von Längsnuten nach  
DIN 138 und DIN 6885

broaching keyways according  
DIN 138 und DIN 6885

## Typ NPV

Schneideinsatz  
Nuttiefe bis 10 mm,  
Toleranzklassen C11 / JS9 / P9 / H9 / inch

insert  
depth of groove up to 10 mm,  
tolerance grade C11 / JS9 / P9 / H9 / inch

D min. 22 - 45 mm  
B = 5 - 20

D min. 22 - 45 mm  
B = 5 - 20

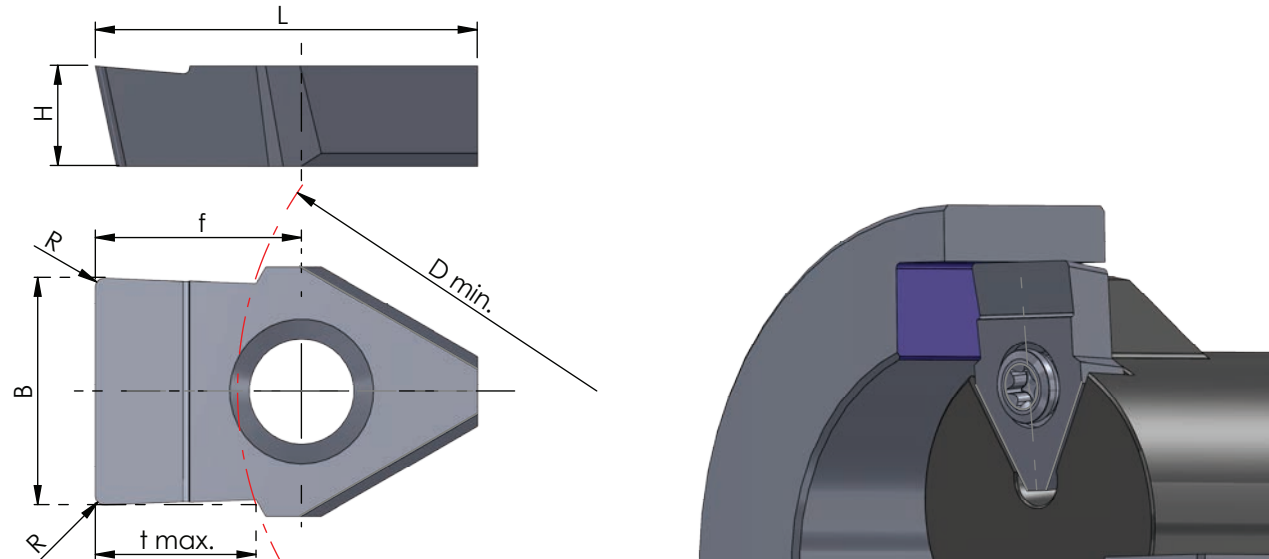

Abmessungen in mm

dimensions in mm

Bestellnummer part number	Abmessungen in mm							Schneideinsatz nach DIN	insert according DIN	Schneideinsatz according DIN			für Klemmhalter for toolholder type
	D min.	B	R	f	L	t max.	H			K10F	AL41F	P18C	
NPV.1001.03	38	10.01	0.3	8	17.3	4.2	5.3	JS9 DIN 6885 leichter Sitz slightly fit	●	●	●	NHV.38..(NHV.30/22..)	
NPV.1202.03	38	12.02	0.3	10.9	20.1	5.7	5.3		●	●	●	NHV.38..(NHV.30/22..)	
NPV.1202.05	38	12.02	0.5	10.9	20.1	8.5	5.3		●	●	●	NHV.38..(NHV.30/22..)	
NPV.1402.03	45	14.02	0.3	10.9	20.1	7.5	6.3		●	●	●	NHV.45..(NHV.38/30/22..)	
NPV.1602.03	45	16.02	0.3	10.9	20.1	7.5	6.3		●	●	●	NHV.45..(NHV.38/30/22..)	
NPV.1802.05	45	18.02	0.4	10.9	20.1	9.5	6.3		●	●	●	NHV.45..(NHV.38/30/22..)	
NPV.2002.05	45	20.02	0.5	10.9	20.1	10	6.3		●	●	●	NHV.45..(NHV.38/30/22..)	
NPV.0998.03	38	9.98	0.3	8	17.3	4.2	5.3	p9 DIN 6885 fester Sitz strong fit	●	●	●	NHV.38..(NHV.30/22..)	
NPV.1197.03	38	11.98	0.3	10.9	20.1	5.7	5.3		●	●	●	NHV.38..(NHV.30/22..)	
NPV.1397.03	45	13.97	0.3	10.9	20.1	7.5	6.3		●	●	●	NHV.45..(NHV.38/30/22..)	
NPV.1597.03	45	15.97	0.3	10.9	20.1	7.5	6.3		●	●	●	NHV.45..(NHV.38/30/22..)	
NPV.1797.05	45	17.97	0.4	10.9	20.1	9.5	6.3		●	●	●	NHV.45..(NHV.38/30/22..)	
NPV.1997.05	45	19.97	0.5	10.9	20.1	10	6.3		●	●	●	NHV.45..(NHV.38/30/22..)	

Klemmhalter in Klammer sind nicht optimal in der Unterstützung. Schnittwerte reduzieren!  
Weitere HM Sorten können Sie in der Sortenübersicht im Kapitel "Technische Hinweise" und der Preisliste finden.  
Bestellbeispiel:  
für Sorte AL41F:  
NPV.1001.03/AL41F

Please note that toolholders in brackets are not the optimal choice. If using them, please reduce the cutting data!  
More carbide grades you can find in the grades summary in the chapter "Technical Instructions" and in the price list.  
order example:  
grade AL41F:  
NPV.1001.03/AL41F

## NUTSTOSEN

von Längsnuten nach  
DIN 138 und DIN 6885

broaching keyways according  
DIN 138 und DIN 6885

## Typ NPV

Schneideinsatz  
Nuttiefe bis 10 mm,  
Toleranzklassen C11 / JS9 / P9 / H9 / inch

D min. 22 - 45 mm  
B = 5 - 20

insert  
depth of groove up to 10 mm,  
tolerance grade C11 / JS9 / P9 / H9 / inch

D min. 22 - 45 mm  
B = 5 - 20

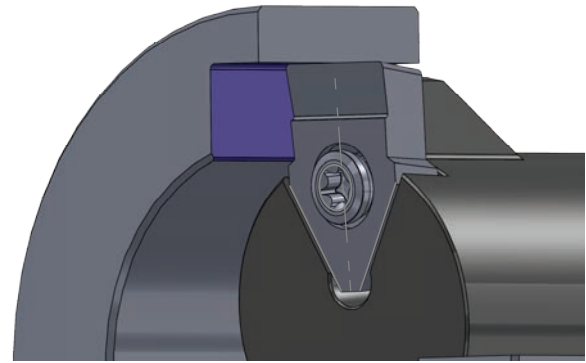
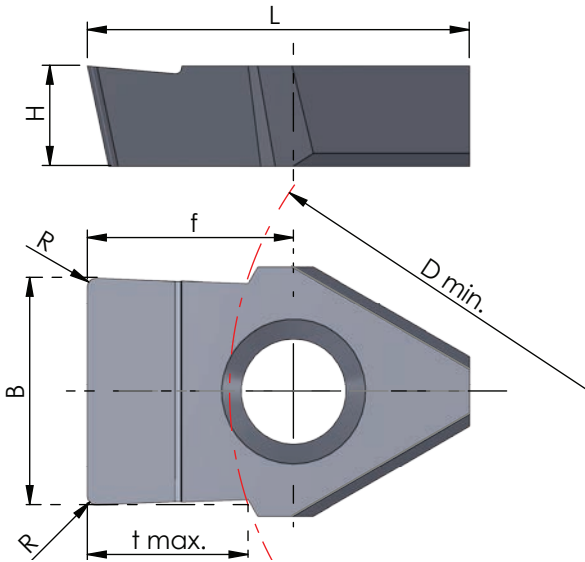

Abmessungen in mm

dimensions in mm



Bestellnummer part number	Abmessungen in mm							Schneideinsatz nach DIN	insert according DIN	K10F AL41F P18C	für Klemmhalter for toolholder type
	D min.	B	R	f	L	t max.	H				
NPV.1013.105	38	10.13	1.05	10.9	20.1	4.2	5.3	C11 DIN 138 Standard	●	NHV.38..(NHV.30/22..)	
NPV.1215.135	38	12.15	1.35	10.9	20.1	5.1	5.3				
NPV.1215.175	38	12.15	1.75	10.9	20.1	6.6	5.3				
NPV.1215.225	38	12.15	2.25	10.9	20.1	8.5	5.3				
NPV.100H.03	38	10.02	0.3	8	17.3	4.2	5.3	H9	●	NHV.38..(NHV.30/22..)	
NPV.120H.03	38	12.02	0.3	10.9	20.1	5.7	5.3	DIN 6885	●	NHV.38..(NHV.30/22..)	

Klemmhalter in Klammer sind nicht optimal in der Unterstützung. Schnittwerte reduzieren!  
Weitere HM Sorten können Sie in der Sortenübersicht im Kapitel "Technische Hinweise" und der Preisliste finden.  
Bestellbeispiel:  
für Sorte AL41F:  
NPV.1013.105/AL41F

Please note that toolholders in brackets are not the optimal choice. If using them, please reduce the cutting data!  
More carbide grades you can find in the grades summary in the chapter "Technical Instructions" and in the price list.  
order example:  
grade AL41F:  
NPV.1013.105/AL41F

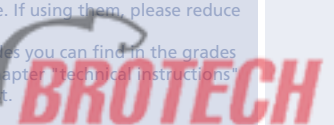

# NUTSTOSEN

von Längsnuten nach  
DIN 138 und DIN 6885

broaching keyways according  
DIN 138 und DIN 6885

# NV15. ...45.1 / Typ NPV. ...45.1

Schneideinsatz  
Fasen 45°

D min. 15 mm  
D min. 22 / 38 mm

insert  
chamfering 45°

D min. 15 mm  
D min. 22 / 38 mm

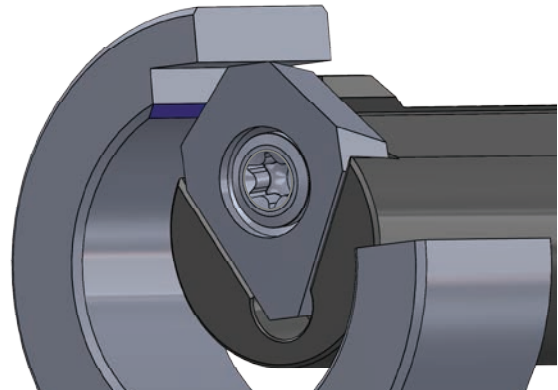
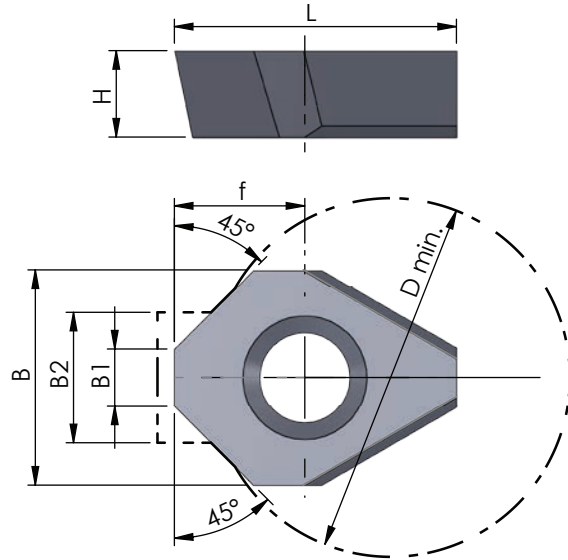

Abmessungen in mm

dimensions in mm

Bestellnummer part number	D min.	B	B1	B2 Nutenbreite width of groove	H	f	L	für Klemmhalter for toolholder type			
								K10F	AL41F	P18C	
NV15.4545.1	15	10.4	2.5	5 - 8	3.2	6.5	13	●			NHV.15....
Bestellnummer part number	D min.	B	B1	B2 Nutenbreite width of groove	H	f	L	K10F	AL41F	P18C	für Klemmhalter for toolholder type
NPV.3045.1	22	13.2	3.5	6 - 10	5.3	8	17.3	●			NHV.22....
NPV.6045.1	38	13.2	6.0	10 - 12	5.3	10.9	20.2	●			NHV.38....(NHV.30/22. ...)



Klemmhalter in Klammer sind nicht optimal in der Unterstützung. Schnittwerte reduzieren!  
Weitere HM Sorten können Sie in der Sortenübersicht im Kapitel "Technische Hinweise" und der Preisliste finden.  
Bestellbeispiel:  
für Sorte AL41F:  
NPV.3045.1/AL41F

Please note that toolholders in brackets are not the optimal choice. If using them, please reduce the cutting data!  
More carbide grades you can find in the grades summary in the chapter "Technical Instructions" and in the price list.  
order example:  
grade AL41F:  
NPV.3045.1/AL41F

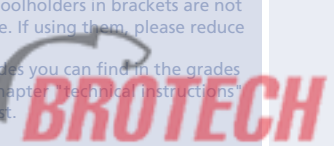



## NUTSTOSEN

von Längsnuten nach  
DIN 138 und DIN 6885

broaching keyways according  
DIN 138 und DIN 6885

## Typ NPU.SW

Schneideinsatz  
für Innensechskant

insert  
for hexagon socket

Schlüsselweite ab SW 2.5 - 8 mm

wrench size from 2.5 - 8 mm

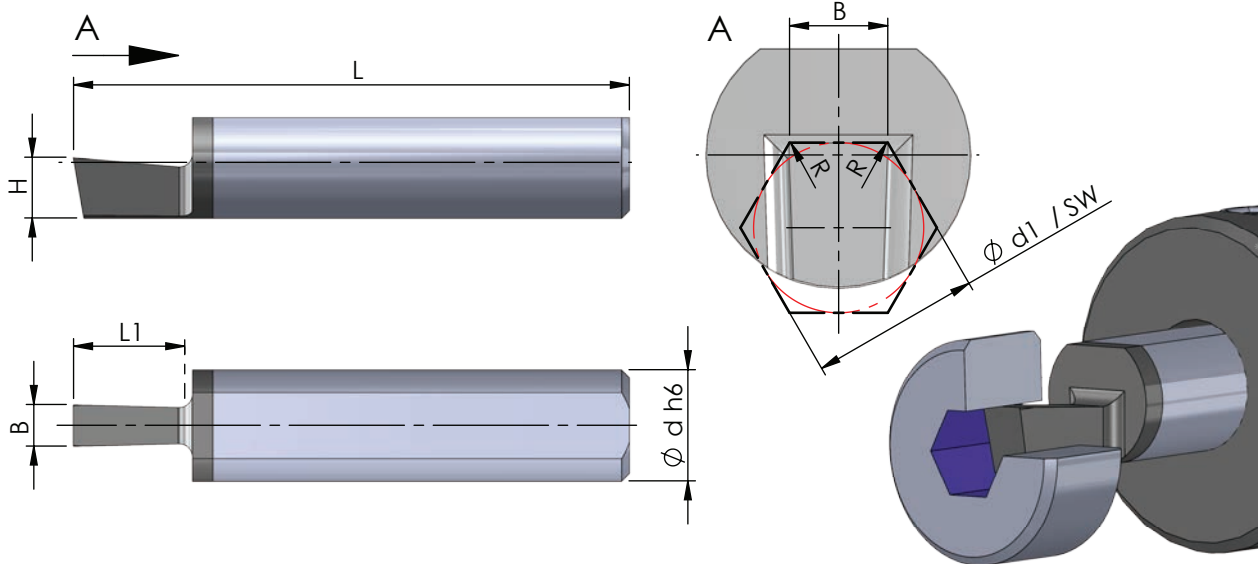

Nutmaß nach DIN

width of the groove according to DIN

Abmessungen in mm

dimensions in mm



Bestellnummer part number	Schlüsselweite SW wrench size	Ø d1 Bohrung Ø d1 hole	B	H +0.05	R	L	L1	Ø d h6				für Klemmhalter for toolholder type
									K10F	AL41F	P18C	
NPU.SW25.25.01	2.5	2.5	1.48	2.0	0.05	30	4.5	7		●		NHU...
NPU.SW30.30.01	3.0	3.0	1.77	2.5	0.05	30	5.0	7		●		
NPU.SW35.35.01	3.5	3.5	2.07	2.9	0.05	30	6.0	7		●		
NPU.SW40.40.01	4.0	4.0	2.35	3.3	0.05	35	6.5	7		●		
NPU.SW45.45.01	4.5	4.5	2.64	3.8	0.1	35	7.5	7		●		
NPU.SW50.50.01	5.0	5.0	2.95	4.2	0.1	35	9.5	7		●		
NPU.SW60.60.01	6.0	6.0	3.53	5.2	0.1	35	9.5	7		●		
NPU.SW80.80.01	8.0	8.0	4.70	5.7	0.1	37	12.5	7		●		

Weitere HM Sorten können Sie in der Sortenübersicht im Kapitel "Technische Hinweise" und der Preisliste finden.

Bestellbeispiel:  
für Sorte AL41F:  
NPU.SW25.25.01/AL41F

More carbide grades you can find in the grades summary in the chapter "technical instructions" and in the price list.

order example:  
grade AL41F:  
NPU.SW25.25.01/AL41F

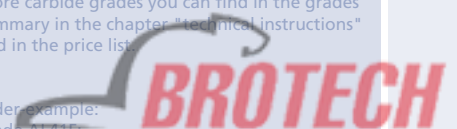

# NUTSTOSEN

von Längsnuten nach  
DIN 138 und DIN 6885

broaching keyways according  
DIN 138 und DIN 6885

# Typ NP10.SW

Schneideinsatz  
für Innensechskant

insert  
for hexagon socket

Schlüsselweite ab SW 10 - 16 mm

wrench size from 10 - 16 mm

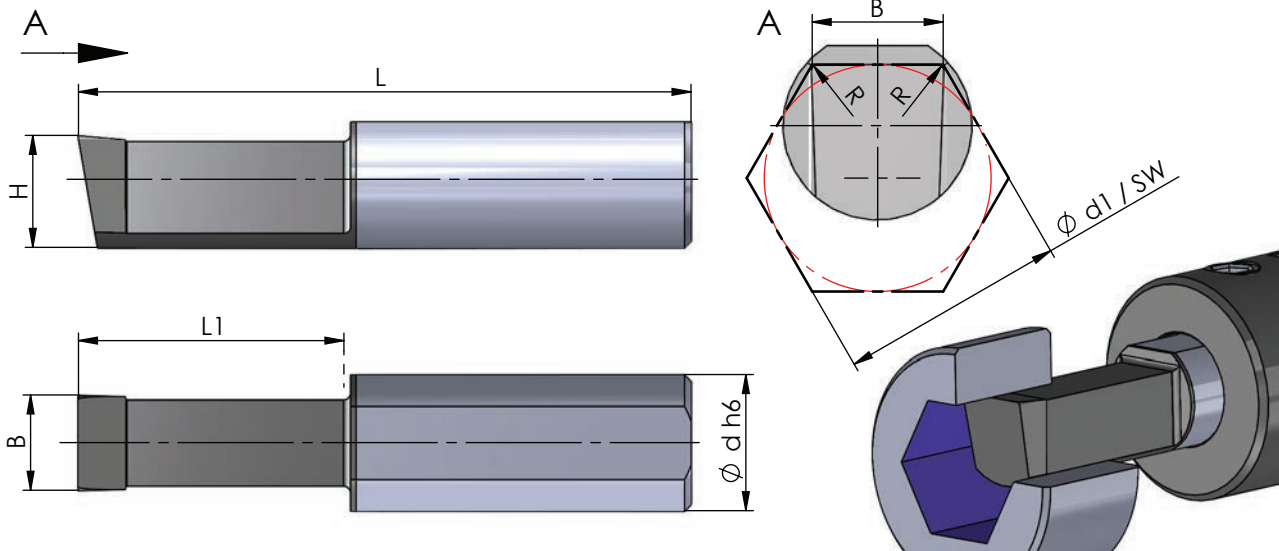

Nutmaß nach DIN

width of the groove according to DIN

Abmessungen in mm

dimensions in mm

Bestellnummer part number	Schlüsselweite SW wrench size	Ø d1 Bohrung Ø d1 hole	B	H +0.05	R	L	L1	Ø d h6	für Klemmhalter for toolholder type		
									K10F	AL41F	P18C
NP10.SW10.10.02	10	10	5.85	9.0	0.2	40	15	10	●	●	●
NP10.SW12.12.03	12	12	7.02	8.2	0.3	45	20	10	●	●	●
NP10.SW14.14.03	14	14	8.18	7.5	0.3	45	20	10	●	●	●
NP10.SW16.16.04	16	16	9.34	6.2	0.4	50	25	10	●	●	●



Weitere HM Sorten können Sie in der Sortenübersicht im Kapitel "Technische Hinweise" und der Preisliste finden.

Bestellbeispiel:  
für Sorte AL41F:  
NPU.SW10.10.02/AL41F

More carbide grades you can find in the grades summary in the chapter "technical instructions" and in the price list.

order example:  
grade AL41F:  
NPU.SW10.10.02/AL41F

## NUTSTOSEN

von Längsnuten nach  
DIN 138 und DIN 6885

broaching keyways according  
DIN 138 und DIN 6885

## Sets

SET - NPU

Toleranzklasse JS9

tolerance grade JS9

SET - NP10

Toleranzklasse JS9

tolerance grade JS9

Bestellnummer  
part number

Inhalt  
Content

K10F  
AL41F  
P18C

SET - NPU



- Toleranzklasse JS9  
D min. 6  
B = 2 / 3 / 4

- tolerance grade JS9  
D min. 6  
B = 2 / 3 / 4

**Halter / toolholder:**

1 x NHU.0025.1

**Schneideinsatz / insert:**

1 x NPU.0200.01.1

1 x NPU.0300.01.1

1 x NPU.0400.01.1

•  
•  
•

Bestellnummer  
part number

Inhalt  
Content

K10F  
AL41F  
P18C

SET - NP10



- Toleranzklasse JS9  
D min. 10  
B = 4 / 5

- tolerance grade JS9  
D min. 10  
B = 4 / 5

**Halter / toolholder:**

1 x NH10.0025.1

**Schneideinsatz / insert:**

1 x NP10.400.02.3

1 x NP10.500.02.3

•  
•

## NUTSTOSEN

von Längsnuten nach  
DIN 138 und DIN 6885

broaching keyways according  
DIN 138 und DIN 6885

## Sets

SET - NPV

Toleranzklasse JS9

tolerance grade JS9

	Bestellnummer part number	Inhalt Content	K10F AL41F P18C
	<p>SET - NPV</p> <ul style="list-style-type: none"> <li>• Toleranzklasse JS9 D min. 22 / 30 B = 5.01 / 6.01 / 8.01</li> <li>• tolerance grade JS9 D min. 22 / 30 B = 5.01 / 6.01 / 8.01</li> </ul>	<p><b>Halter / toolholder:</b> 1 x NHV.22.0025.1</p> <p><b>Schneideinsatz / insert:</b> 1 x NPV.0501.02 1 x NPV.0601.02 1 x NPV.0801.02</p>	<p>• • •</p>



## NUTSTOSSEN

von Längsnuten nach  
DIN 138 und DIN 6885

broaching keyways according  
DIN 138 und DIN 6885

## Technische Hinweise

Grundsätzliche Informationen zum Nutstossen

Technical instructions,  
Basic informations about broaching keyways

### Grundsätzliche Informationen zum Nutstossen

- Achten Sie auf den Freistich am Ende der geräumten Nut, damit das Werkzeug frei auslaufen kann.
- Während das Werkzeug zurückfährt, sollte die Schneide den Nutengrund nicht berühren.
- Das ausjustieren des Werkzeuges ist unerlässlich. Überprüfen sie deshalb den Durchmesser des Werkstückes genau, bevor Sie den ersten Einsatz fahren.
- Wenn Sie Öl oder eine Emulsion verwenden, werden die Späne vom Werkstück weggespült und Sie erzielen gleichzeitig eine perfekte Oberfläche.
- Wenn Sie das Werkzeug nach oben hin ausrichten, fallen die Späne automatisch nach unten, von der Schneide weg.
- Vermeiden Sie einen unterbrochenen Schnitt

#### Basic informations about broaching keyways

- an undercut is necessary at the end of the broached groove for tool run out.
- the insert should not touch the bottom of the groove as the tool retracts.
- setting of the tool is very important. Check accurate the component diameter before taking the first pass.
- using oil or emulsion helps to achieve better surface finish and flush chips out of the component.
- the tool should be set at the 12 o'clock position to ensure that chips fall away from the groove.
- avoid interrupted cutting.

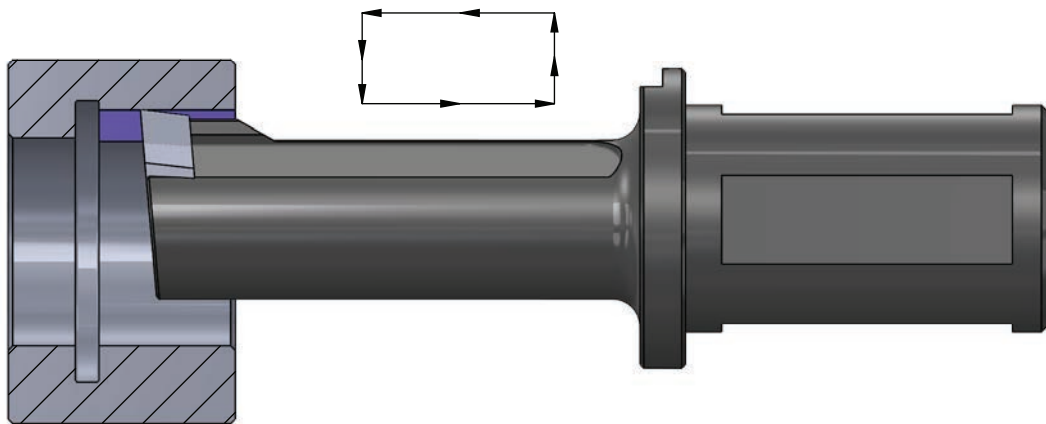

## NUTSTOSEN

von Längsnuten nach  
DIN 138 und DIN 6885

broaching keyways according  
DIN 138 und DIN 6885

## Impressionen

impressions

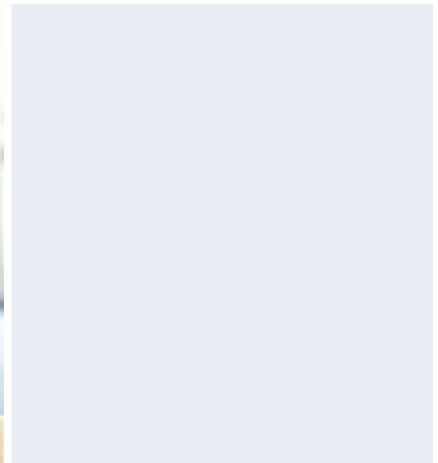
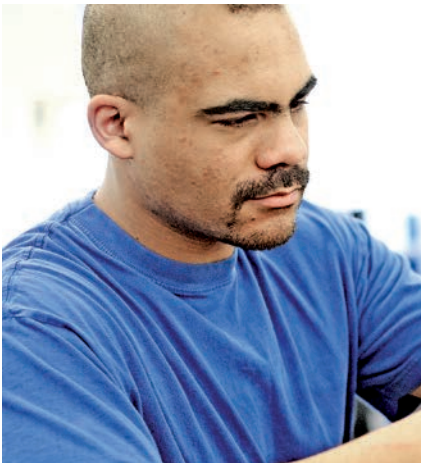
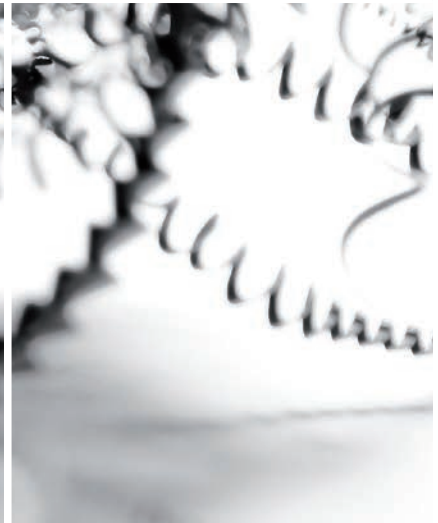
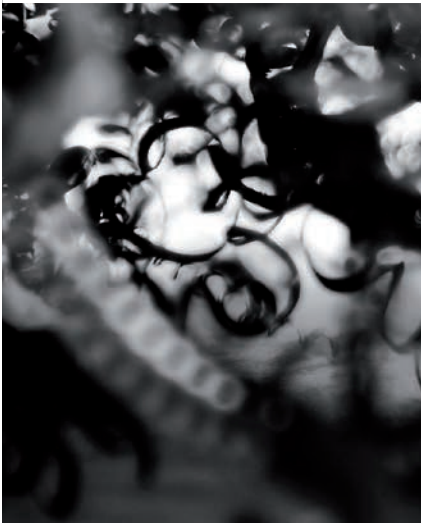
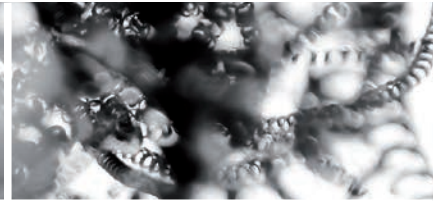
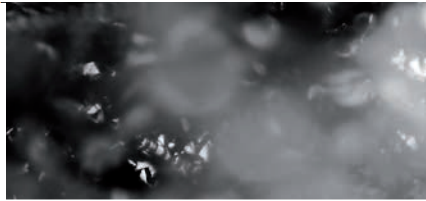

## NUTSTOSSEN

von Längsnuten nach  
DIN 138 und DIN 6885

broaching keyways according  
DIN 138 und DIN 6885

## Technische Hinweise

Hartmetallsorten und Beschichtungen

Technical instructions,  
carbide grades and coatings

### K10F

Universell einsetzbares Feinkornhartmetall mit guter Verschleißfestigkeit. Unbeschichtet geeignet für Anwendungen mit niedrigen und mittleren Schnittgeschwindigkeiten, sowie die Bearbeitung von Nicht-eisenmetallen.

All purpose micrograin carbide with good abrasion resistance. Uncoated for applications with low or medium cutting speeds and machining of non-ferrous materials.

### CBN

Zähe CBN-Sorte für Anwendungen mit niedrigen Schnittgeschwindigkeiten. Geeignet für gehärtete Stähle, unterbrochene Schnitte und Grauguss.

Ductile CBN grade for applications with lower cutting speed. Suitable for hardened steel, interrupted cuts and cast iron.

### CN45F

Universell einsetzbare PVD-TIN-Beschichtung. Diese Allround-Sorte ist für niedrige und mittlere Schnittgeschwindigkeiten mit Einschränkung bei NE-Metallen

PVD-TIN coating - all purpose, all around grade is suitable for low and medium cutting speed with restrictions on non-ferrous materials.

### AL41F

Sehr universell einsetzbare TIALN-Beschichtung mit hoher Temperaturbeständigkeit bei hoher Härte. Sehr gut geeignet auch für NE-Metalle.

TIALN coating - very universal with a high resistance to high temperature and hardness. Very suitable also for non-ferrous metals.

### PD2F

Beschichtung für den universellen Einsatz bei niedrigen und mittleren Schnittgeschwindigkeiten.

Coating for universal use with medium and low speed.

### XC2A

Beschichtung mit einer excellenten Warmhärte, Oxidationsbeständigkeit und thermischen Isolationsfähigkeit. Ideal für Hartzerspannung >60HRC

Coating with excellent hot hardness, high oxidation resistance and thermal insulation capacity. Perfect for hard machining >60 HRC.



## NUTSTOSSEN

von Längsnuten nach  
DIN 138 und DIN 6885

broaching keyways according  
DIN 138 und DIN 6885

## Technische Hinweise

Hartmetallsorten und Beschichtungen

Technical instructions,  
carbide grades and coatings

### P01C

Beschichtung für die Bearbeitung in zähen Materialien bei niedrigen und mittleren Schnittgeschwindigkeiten.

Coating for the processing in tough material with medium or low cutting speed

### P03C

Beschichtung für die Bearbeitung von schwer zerspanbaren Materialien. Sehr gut auch für die Trockenbearbeitung geeignet.

Coating for materials which are difficult to machine. Perfect to use for dry machining.

### P07C

Beschichtung für die Bearbeitung von Titan, Edelstahl und Molybdän.

Coating to machine titanium, stainless steel and molybdenum.

### P18C

Universell einsetzbare Hochleistungsschicht mit hoher Oxidationsbeständigkeit, Verschleißfestigkeit und Warmhärte.

Very universal high performance coating with high oxidation resistance, wear resistance and hot hardness resistance.

### NEME

Beschichtung für die Bearbeitung von Aluminium, Al-Legierungen, NE-Metallen und Composite-Werkstoffen.

Coating for machining aluminium, alloys, non-ferrous metals and composite materials.





## NUTSTOSSEN

von Längsnuten nach  
DIN 138 und DIN 6885

broaching keyways according  
DIN 138 und DIN 6885

## Technische Hinweise

Schnittdaten

Technical instructions,  
cutting data

### Richtwerte zum Nutenstossen

approximate value for broaching

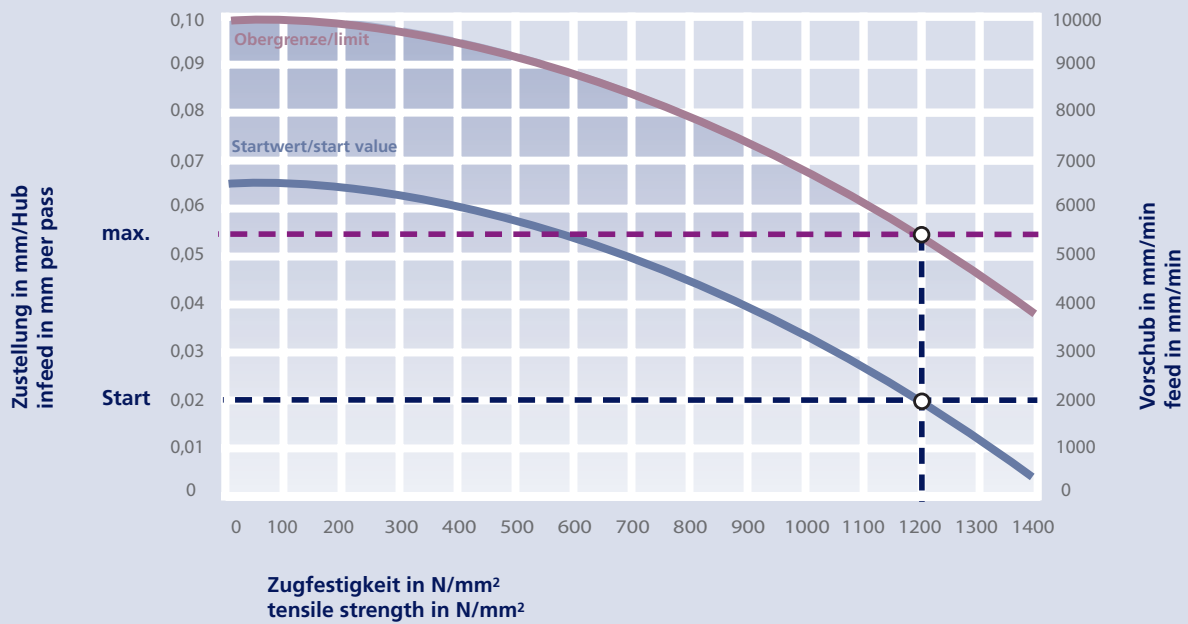

#### Beispiel:

Vergütungsstahl z.B.  
42CrMo4 mit 1200 N/mm<sup>2</sup>

- Zustellung pro Hub  
0.02 - 0.055 mm
- Vorschub  
2000 - 5500 mm/min

#### example:

heat-treated steel  
for instance 42CrMo4  
with 1200 N/mm<sup>2</sup>

- infeed per pass  
0.02 - 0.055 mm
- feed 2000 - 5500 mm/min

## NUTSTOSEN

von Längsnuten nach  
DIN 138 und DIN 6885

broaching keyways according  
DIN 138 und DIN 6885

## Impressionen

impressions

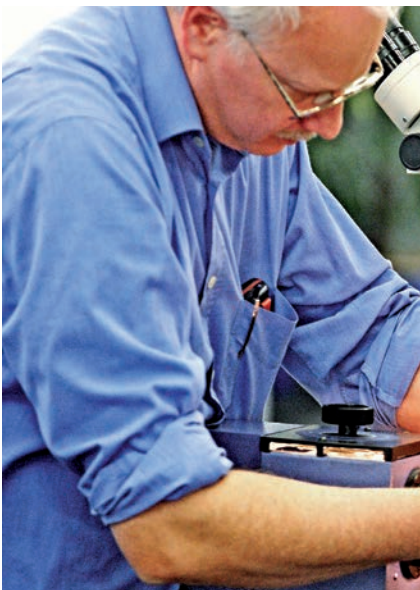
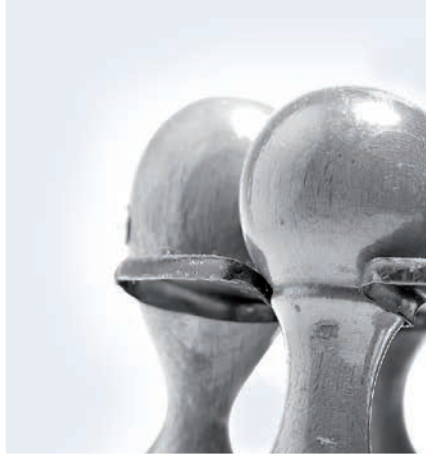



# Fräsen milling

## Inhalt

content

	<p><b>MIKROMILL</b></p>	<p>Nut- und Formzirkularfräsen drei- und vierschneidig, ab Ø 1.3 mm</p> <p>Groove milling by circular interpolation with three and four cutting edges, starting at Ø 1.3 mm</p>	<p><b>312</b></p>	
	<p><b>MINIMILL</b></p>	<p>Nut- und Formzirkularfräsen drei- und sechsschneidig, ab Ø 10 mm</p> <p>Groove milling by circular interpolation with three and six cutting edges, starting at Ø 10 mm</p>	<p><b>334</b></p>	
	<p><b>SYSTEM 500</b></p>	<p>Nut- und Formfräsen Nut- und Trennfräsen</p> <p>Groove milling by circular interpolation groove milling and slotting cutter</p>	<p><b>430</b></p>	
	<p><b>rotaline</b></p>	<p>Ausspindeln ab Ø 0.4 mm</p> <p>Precision boring starting at Ø 0.4 mm</p>	<p><b>460</b></p>	



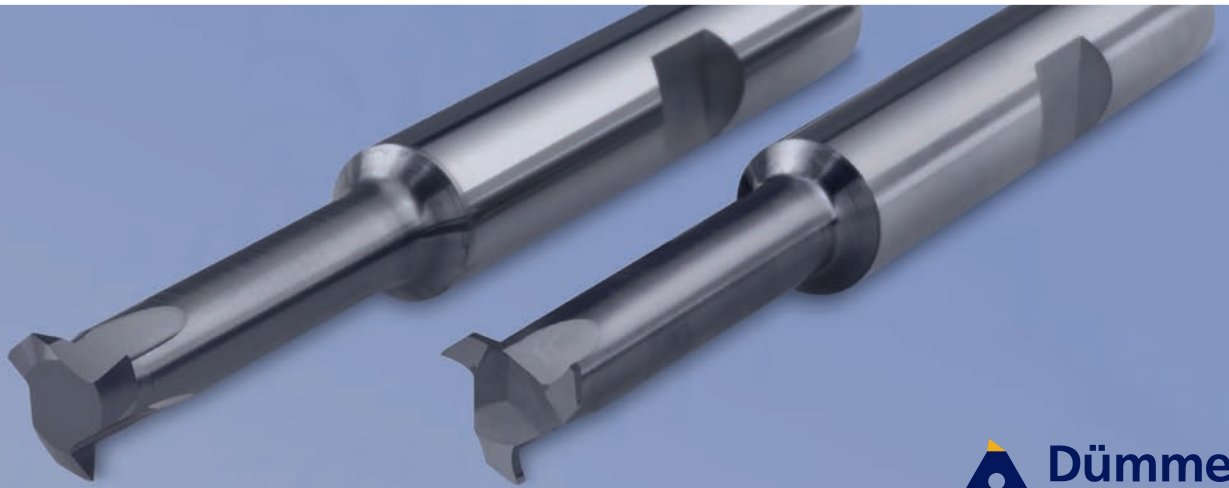

## MIKROMILL



**Nut- und Formzirkularfräsen drei- und vierschneidig  
ab Ø 1.3 mm**

**Groove milling by circular interpolation with  
three and four cutting edges starting at Ø 1.3 mm**



## MIKROMILL

Nut- und Formzirkularfräsen

groove milling  
by circular interpolation

## Übersicht

summary

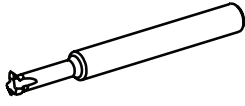

Allgemeine Beschreibung

general instructions

... 315

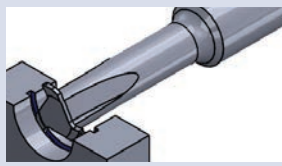

**Schneidplatten  
Nutfräsen**

**inserts  
groove milling**

**Maße  
dimensions**

**Seite  
page**

**Typ MA6 / MA8**

Nutfräsen allgemein

groove milling general use

D min. 6 / 8

... 316

**Typ MB6 / MB8**

Nutfräsen allgemein

groove milling general use

D min. 6 / 8

... 317

**Typ MA6 / MA8 / MA10**

Nutfräsen  
Vollradius

groove milling  
full radius

D min.  
4 / 6 / 8 / 10

... 318

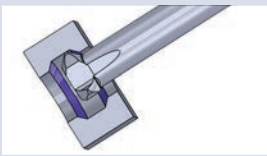

**Schneidplatten  
Vorwärts- und  
Rückwärtsfasen**

**inserts  
forward and backward  
chamfering**

**Maße  
dimensions**

**Seite  
page**

**Typ MA6 / MA8**

Vorwärts- und Rückwärtsfasen

forward and backward chamfering

D min. 6 / 8

... 319

**Typ MB6 / MB8**

Vorwärts- und Rückwärtsfasen

forward and backward chamfering

D min. 6 / 8

... 320

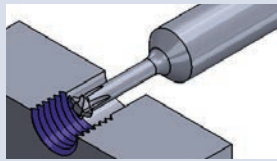

**Schneidplatten  
Gewindefräsen, innen**

**inserts  
threading, internal**

**Maße  
dimensions**

**Seite  
page**

**Typ MA3 / MA5**

metrisches ISO-Gewinde,  
Teilprofil, innen

metric ISO-thread,  
partial profile, internal

ab / starting at  
M2 x 0.4

... 321

**Typ MA3 / MA5 /  
MA6 / MA8**

metrisches ISO-Feingewinde,  
Teilprofil, innen

metric ISO-fine thread,  
partial profile, internal

ab / starting at  
M1.6 x 0.35

... 322

**Typ MB6 / MB8**

metrisches ISO-Feingewinde,  
Teilprofil, innen

metric ISO-fine thread,  
partial profile, internal

ab / starting at  
M7 x 0.5

... 323

**Typ MA4 / MA6**

metrisches ISO-Gewinde,  
Vollprofil, innen

metric ISO-thread,  
full profile, internal

ab / starting at  
M3 x 0.35

... 324

**Typ MA8 / MA10**

metrisches ISO-Gewinde,  
Vollprofil, innen

metric ISO-thread,  
full profile, internal

ab / starting at  
M8 x 0.75

... 325

# MIKROMILL

Nut- und Formzirkularfräsen

groove milling  
by circular interpolation

# Übersicht

summary

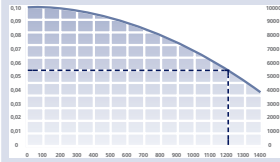

## Technische Hinweise

## Technical Instructions

Seite  
page

Grundsätzliche Informationen zum  
Gewindefräsen

Basic informations about thread  
milling

... 327

Hartmetallsorten und Beschichtungen

carbide grades and coatings

...329

Schnittdaten

cutting data

... 331





## MIKROMILL

Nut- und Formzirkularfräsen

groove milling  
by circular interpolation

## Allgemeine Beschreibung

general instruction

### Mikromill:

Werkzeuge mit Rundschaft für das Nutfräsen und Fasen ab  $\varnothing$  6 mm und Gewindefräsen ab M1.6 im Standard.

#### Mikromill:

Tools with round shaft for groove milling and chamfering starting at  $\varnothing$  6 mm and thread machining starting with a thread of M1.6 in standard.

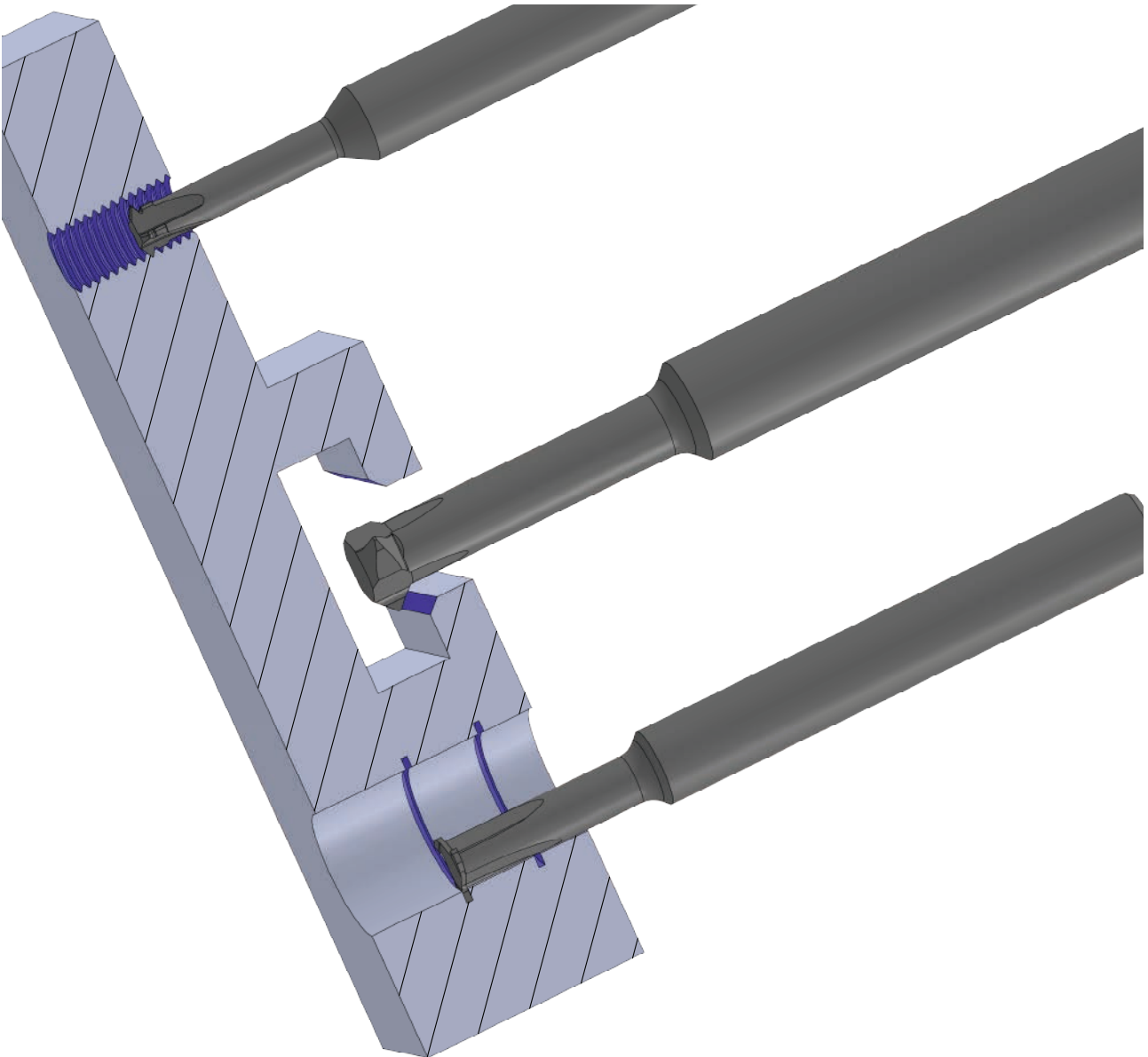

# MIKROMILL

Nut- und Formzirkularfräsen

groove milling  
by circular interpolation

# Typ MA6 / MA8

Nutfräsen allgemein

groove milling general use

D min. 6 / 8 mm

D min. 6 / 8 mm

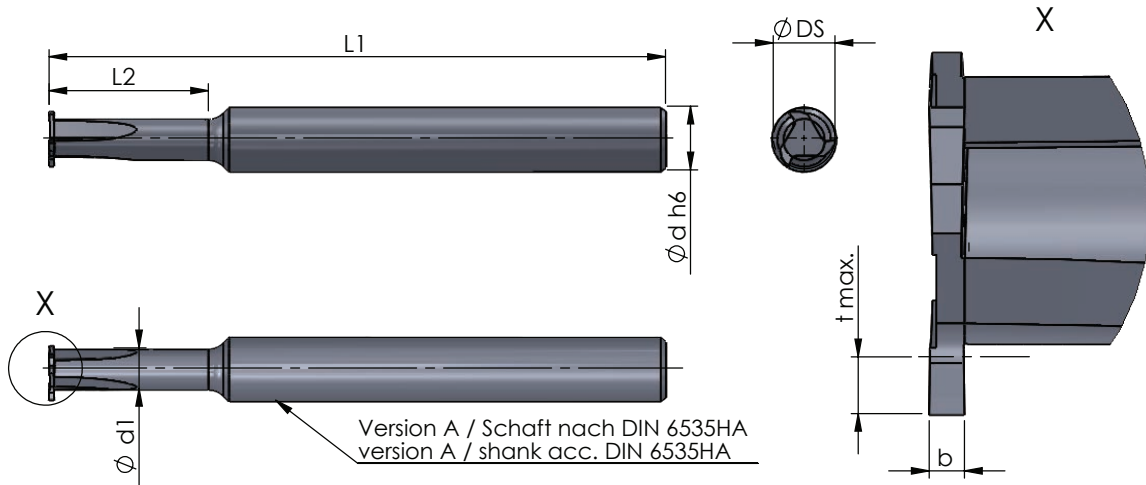

Abmessungen in mm

dimensions in mm

Bestellnummer part number	D min.	b ± 0.02	L2	L1	Ø d h6	Ø d1	Ø DS	t max.	Schneidenzahl cutting edge			
										K10F	AL41F	P18C
MA6.0050.00-15	6	0.5	15	58	6	3.8	5.8	0.8	3	●		
MA6.0060.00-15	6	0.6	15	58	6	3.8	5.8	0.8	3	●		
MA6.0070.00-15	6	0.7	15	58	6	3.8	5.8	0.8	3	●		
MA6.0080.00-15	6	0.8	15	58	6	3.8	5.8	0.8	3	●		
MA6.0090.00-15	6	0.9	15	58	6	3.8	5.8	0.8	3	●		
MA6.0100.00-15	6	1.0	15	58	6	3.8	5.8	0.8	3	●		
MA6.0150.00-15	6	1.5	15	58	6	3.8	5.8	0.8	3	●		
MA8.0070.00-25	8	0.7	25	68	8	5	7.8	1.2	3	●		
MA8.0080.00-25	8	0.8	25	68	8	5	7.8	1.2	3	●		
MA8.0090.00-25	8	0.9	25	68	8	5	7.8	1.2	3	●		
MA8.0100.00-25	8	1.0	25	68	8	5	7.8	1.2	3	●		
MA8.0150.00-25	8	1.5	25	68	8	5	7.8	1.2	3	●		
MA8.0200.00-25	8	2.0	25	68	8	5	7.8	1.2	3	●		

Weitere HM Sorten können Sie in der Sortenübersicht im Kapitel "Technische Hinweise" und der Preisliste finden.

Bestellbeispiel:  
für Sorte AL41F:  
MA6.0050.00-15/AL41F

More carbide grades you can find in the grades summary in the chapter "technical instructions" and in the price list.

order example:  
grade AL41F:  
MA6.0050.00-15/AL41F



## MIKROMILL

Nut- und Formzirkularfräsen

groove milling  
by circular interpolation

## Typ MB6 / MB8

Nutfräsen allgemein

D min. 6 / 8 mm

groove milling general use

D min. 6 / 8 mm

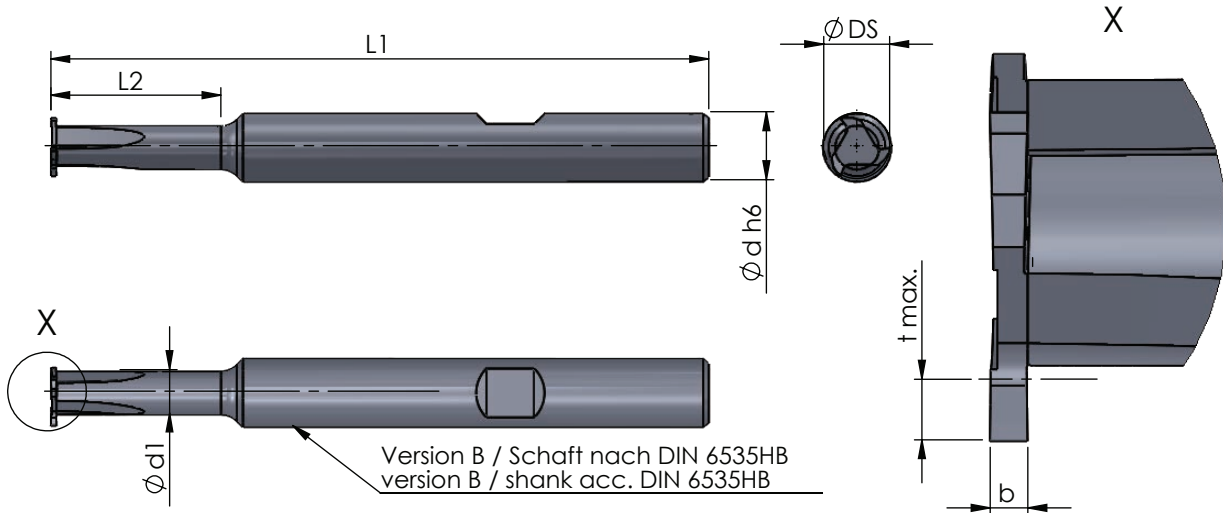

Abmessungen in mm

dimensions in mm

Bestellnummer part number	D min.	b ± 0.02	L2	L1	Ø d h6	Ø d1	Ø DS	t max.	Schneidenzahl cutting edge			
										K10F	AL41F	P18C
MB6.0050.00-15	6	0.5	15	58	6	3.8	5.8	0.8	3		●	
MB6.0060.00-15	6	0.6	15	58	6	3.8	5.8	0.8	3		●	
MB6.0070.00-15	6	0.7	15	58	6	3.8	5.8	0.8	3		●	
MB6.0080.00-15	6	0.8	15	58	6	3.8	5.8	0.8	3		●	
MB6.0090.00-15	6	0.9	15	58	6	3.8	5.8	0.8	3		●	
MB6.0100.00-15	6	1.0	15	58	6	3.8	5.8	0.8	3		●	
MB6.0150.00-15	6	1.5	15	58	6	3.8	5.8	0.8	3		●	
MB8.0070.00-25	8	0.7	25	68	8	5	7.8	1.2	3		●	
MB8.0080.00-25	8	0.8	25	68	8	5	7.8	1.2	3		●	
MB8.0090.00-25	8	0.9	25	68	8	5	7.8	1.2	3		●	
MB8.0100.00-25	8	1.0	25	68	8	5	7.8	1.2	3		●	
MB8.0150.00-25	8	1.5	25	68	8	5	7.8	1.2	3		●	
MB8.0200.00-25	8	2.0	25	68	8	5	7.8	1.2	3		●	

Weitere HM Sorten können Sie in der Sortenübersicht im Kapitel "Technische Hinweise" und der Preisliste finden.

Bestellbeispiel:  
für Sorte AL41F:  
MB6.0050.00-15/AL41F

More carbide grades you can find in the grades summary in the chapter "technical instructions" and in the price list.

order example:  
grade AL41F:  
MB6.0050.00-15/AL41F



# MIKROMILL

Nut- und Formzirkularfräsen

groove milling  
by circular interpolation

# Typ MA6 / MA8 / MA10

Nutfräsen  
Vollradius

groove milling  
full radius

D min. 4 / 6 / 8 / 10 mm

D min. 4 / 6 / 8 / 10 mm

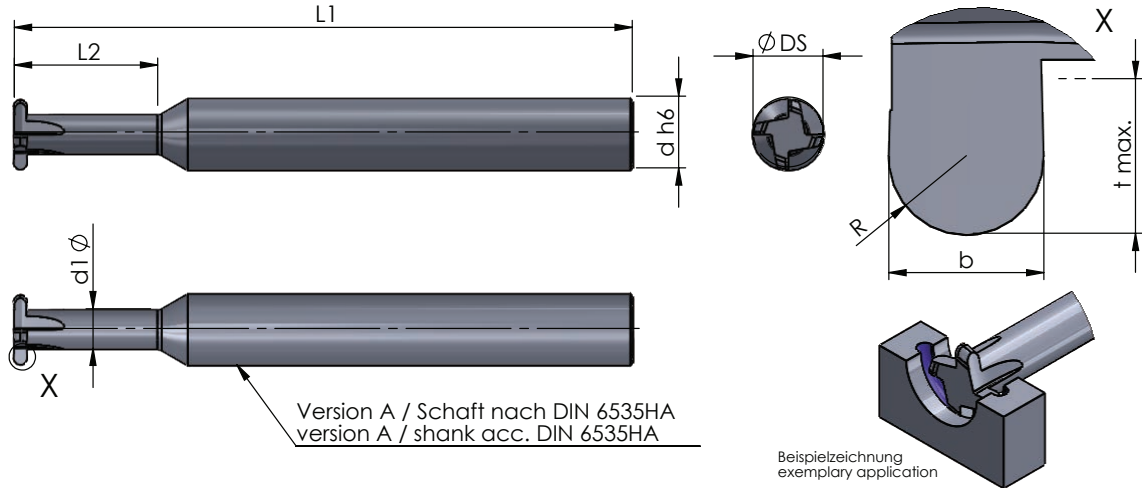

Version A / Schaft nach DIN 6535HA  
version A / shank acc. DIN 6535HA

Abmessungen in mm

dimensions in mm

Bestellnummer part number	Abmessungen in mm / dimensions in mm										Material		
	D min.	b ± 0.02	R	L2	L1	Ø d h6	Ø d1	Ø DS	t max.	Schneidenzahl cutting edge	K10F	AL41F	P18C
MA6.005.10-4	4	1.0	0.5	4	58	6	2.55	3.8	0.5	3			●
MA6.005.10-6	6	1.0	0.5	6	58	6	3.5	5.8	1.0	3			●
MA6.007.15-6	6	1.5	0.75	6	58	6	3.5	5.8	1.0	3			●
MA8.007.15-16	8	1.5	0.75	16	69	8	4.4	7.8	1.5	4			●
MA8.010.20-16	8	2.0	1.0	16	69	8	4.4	7.8	1.5	4			●
MA10.005.10-20	10	1.0	0.5	20	79	10	5.3	9.8	2.0	4			●
MA10.007.15-20	10	1.5	0.75	20	79	10	5.3	9.8	2.0	4			●
MA10.010.20-20	10	2.0	1.0	20	79	10	5.3	9.8	2.0	4			●
MA10.012.25-20	10	2.5	1.25	20	79	10	5.3	9.8	2.0	4			●
MA10.015.30-20	10	3.0	1.5	20	79	10	5.3	9.8	2.0	4			●

Weitere HM Sorten können Sie in der Sortenübersicht im Kapitel "Technische Hinweise" und der Preisliste finden.

Bestellbeispiel:  
für Sorte P18C:  
MA6.005.10-4/P18C

More carbide grades you can find in the grades summary in the chapter "technical instructions" and in the price list.

order example:  
grade P18C:  
MA6.005.10-4/P18C

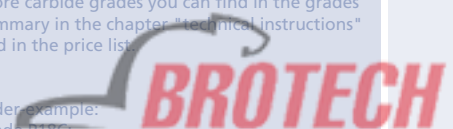

**MIKROMILL**

Nut- und Formzirkularfräsen

groove milling  
by circular interpolation

**Typ MA6 / MA8**

Vorwärts- und Rückwärtsfasen

D min. 6 / 8 mm

forward and backward chamfering

D min. 6 / 8 mm

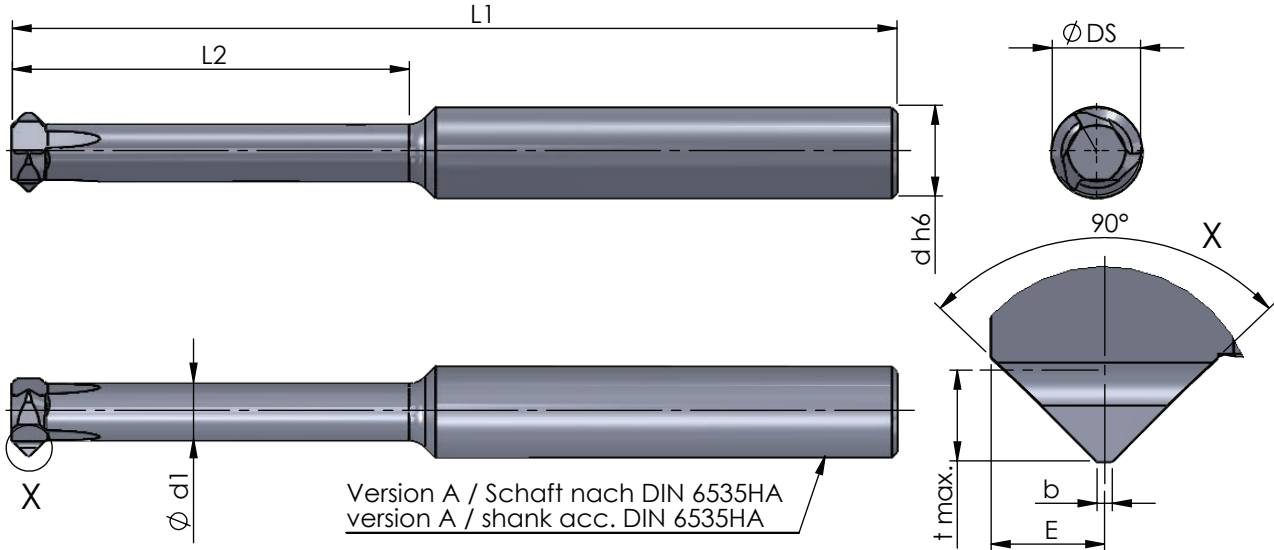

Abmessungen in mm

dimensions in mm

Bestellnummer part number	D min.	b	L2	L1	E	Ø d h6	Ø d1	Ø DS	t max.	Schneidanzahl cutting edge			
											K10F	AL41F	P18C
MA6.4545.02-15	6	0.2	15	58	1	6	4	5.8	0.6	3		●	
MA6.4545.02-25	6	0.2	25	68	1	6	4	5.8	0.6	3		●	
MA8.4545.02-25	8	0.2	25	68	1.5	8	5	7.8	1.2	3		●	
MA8.4545.02-35	8	0.2	35	78	1.5	8	5	7.8	1.2	3		●	

Weitere HM Sorten können Sie in der Sortenübersicht im Kapitel "Technische Hinweise" und der Preisliste finden.

Bestellbeispiel:  
für Sorte AL41F:  
MA6.4545.02-15/AL41F

More carbide grades you can find in the grades summary in the chapter "technical instructions" and in the price list.

order example:  
grade AL41F:  
MA6.4545.02-15/AL41F



# MIKROMILL

Nut- und Formzirkularfräsen

groove milling  
by circular interpolation

# Typ MB6 / MB8

Vorwärts- und Rückwärtsfasen

D min. 6 / 8 mm

forward and backward chamfering

D min. 6 / 8 mm

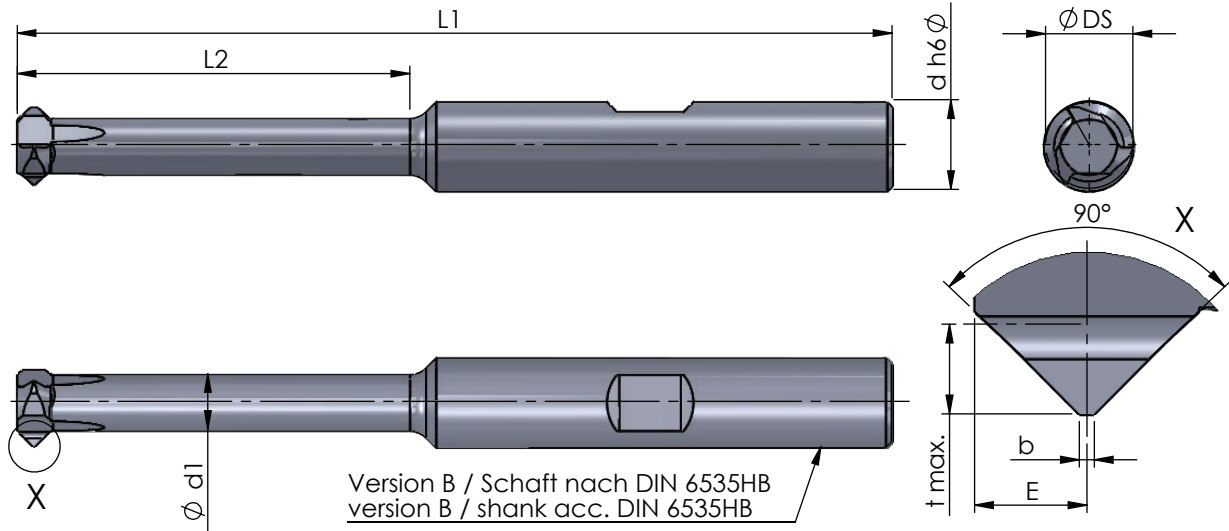

Abmessungen in mm

dimensions in mm

Bestellnummer part number	D min.	b	L2	L1	E	Ø d h6	Ø d1	Ø DS	t max.	Schneidenzahl cutting edge			
											K10F	AL41F	P18C
MB6.4545.02-15	6	0.2	15	58	1	6	4.2	5.8	0.6	3		●	
MB6.4545.02-25	6	0.2	25	68	1	6	4.2	5.8	0.6	3		●	
MB8.4545.02-25	8	0.2	25	68	1.5	8	5	7.8	1.2	3		●	
MB8.4545.02-35	8	0.2	35	78	1.5	8	5	7.8	1.2	3		●	

Weitere HM Sorten können Sie in der Sortenübersicht im Kapitel "Technische Hinweise" und der Preisliste finden.

Bestellbeispiel:  
für Sorte AL41F:  
MB6.4545.02-15/AL41F

More carbide grades you can find in the grades summary in the chapter "technical instructions" and in the price list.

order example:  
grade AL41F:  
MB6.4545.02-15/AL41F

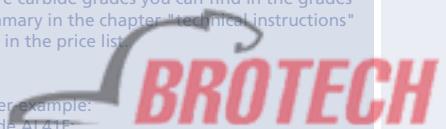

# MIKROMILL

Nut- und Formzirkularfräsen

groove milling  
by circular interpolation

# Typ MA3 / MA5

metrisches ISO-Gewinde,  
Teilprofil, innen

metric ISO-thread,  
partial profile, internal

ab Gewindegröße M2 x 0.4

starting at thread size M2 x 0.4

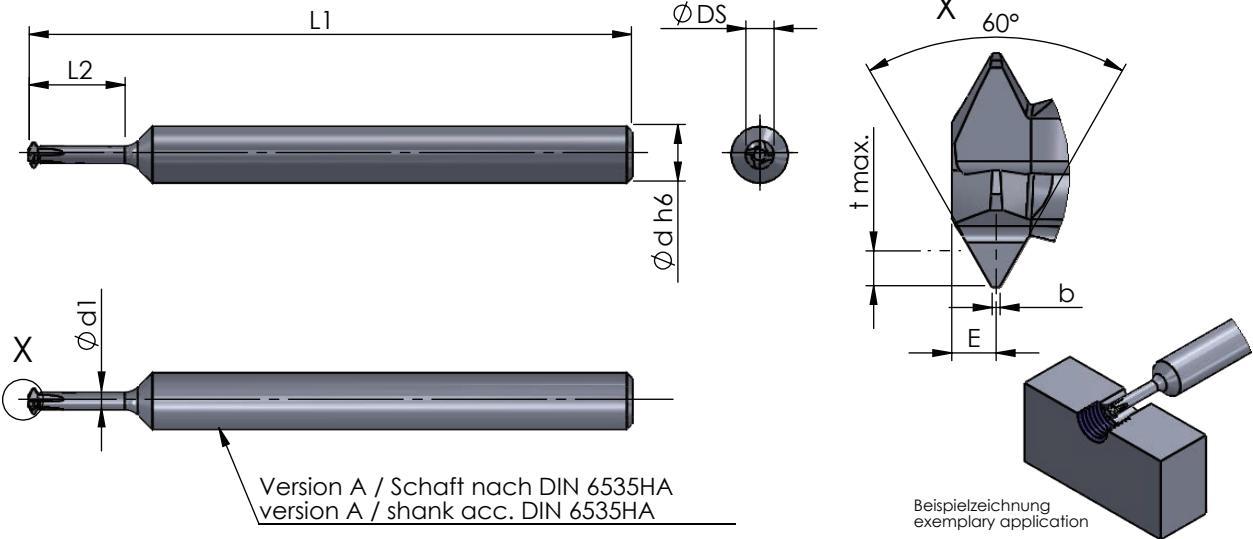

Abmessungen in mm

dimensions in mm

Bestellnummer part number	min. Gewindegröße min. thread size	Steigung P pitch P	L2	L1	b	E	t max.	Ø d h6	Ø d1	Ø DS	Schneidenzahl cutting edge	K10F	AL41F	P18C
MA3.MR20.01-5	M2	0.4-0.45	5	32	0.05	0.3	0.27	3	0.77	1.45	4	●		
MA3.MR25.01-6	M2.5	0.45-0.5	6	32	0.05	0.3	0.29	3	1.06	1.8	4	●		
MA3.MR30.01-7	M3	0.5-0.6	7	32	0.06	0.3	0.35	3	1.27	2.15	4	●		
MA3.MR35.01-8	M3.5	0.6-0.7	8	32	0.07	0.4	0.40	3	1.39	2.4	4	●		
MA5.MR40.01-9	M4	0.7-0.8	9	44	0.08	0.4	0.46	5	1.58	2.7	4	●		
MA5.MR50.01-10	M5	0.8-1.0	10	44	0.1	0.5	0.59	5	2.14	3.57	4	●		
MA5.MR60.01-12	M6	1.0-1.25	12.2	44	0.12	0.6	0.74	5	2.44	4.2	4	●		
MA5.MR70.01-15	M7	1.0-1.25	15.2	44	0.12	0.6	0.74	5	3.34	5.15	4	●		

Weitere HM Sorten können Sie in der Sortenübersicht im Kapitel "Technische Hinweise" und der Preisliste finden.

Bestellbeispiel:  
für Sorte AL41F:  
MA3.MR20.01-5/AL41F

More carbide grades you can find in the grades summary in the chapter "technical instructions" and in the price list.

order example:  
grade AL41F:  
MA3.MR20.01-5/AL41F

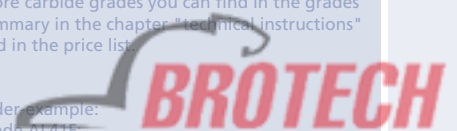

# MIKROMILL

Nut- und Formzirkularfräsen

groove milling  
by circular interpolation

# Typ MA3 / MA5 / MA6 / MA8

metrisches ISO-Feingewinde,  
Teilprofil, innen

metric ISO-fine thread,  
partial profile, internal

ab Gewindegröße M1.6 x 0,35

starting at thread size M1.6 x 0,35

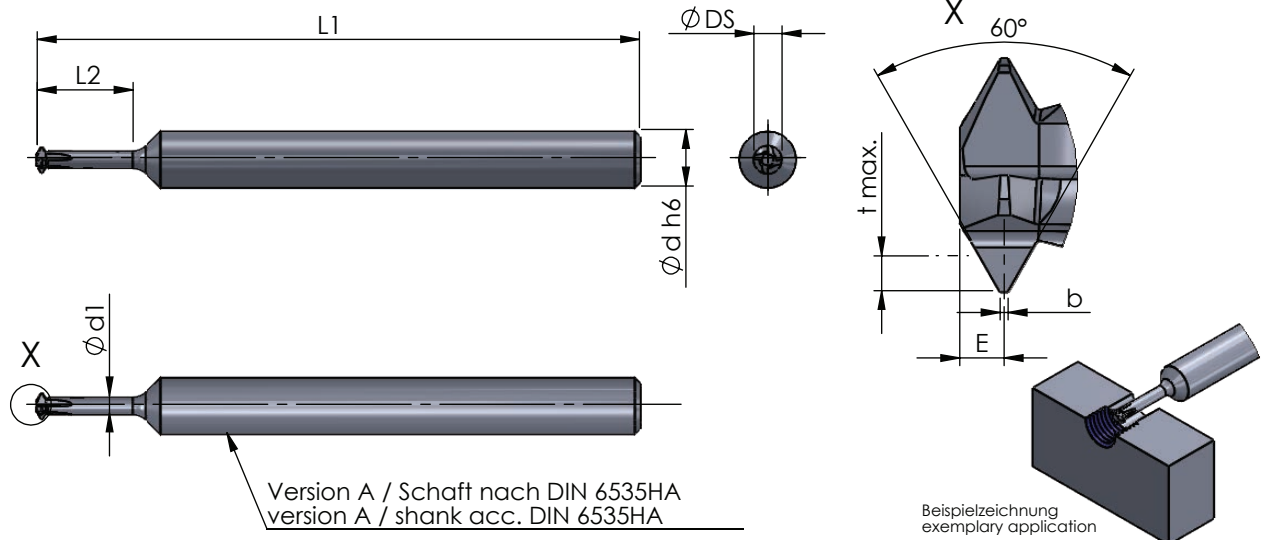

Abmessungen in mm

dimensions in mm

Bestellnummer part number	D min.	Steigung P pitch P	min. Gewindegröße min. thread size	L2	L1	b	E	t max.	Ø d h6	Ø d1	Ø DS	Schneidzahl cutting edge			
													K10F	AL41F	P18C
MA3.0035.01-4	1.3	0.35	M1.6	4	32	0.04	0.2	0.19	3	0.67	1.18	3	●	●	●
MA3.0035.01-5	1.58	0.35	M1.8	5	32	0.04	0.2	0.19	3	0.86	1.38	3	●	●	●
MA3.0040.01-5	2.07	0.4	M2.5	5	32	0.05	0.3	0.22	3	0.92	1.5	4	●	●	●
MA3.0045.01-6	2.52	0.45	M3.0	6	32	0.06	0.3	0.25	3	1.28	1.95	4	●	●	●
MA3.0050.01-7	2.96	0.5	M3.5	7	32	0.06	0.3	0.27	3	1.67	2.4	4	●	●	●
MA3.0060.01-8	3.35	0.6	M4.0	8	32	0.08	0.4	0.33	3	1.93	2.8	4	●	●	●
MA5.0070.01-9	3.74	0.7	M4.5	9	44	0.09	0.4	0.38	5	2.12	3.1	4	●	●	●
MA5.0080.01-10	4.63	0.8	M5.5	10	44	0.10	0.5	0.43	5	2.97	4.1	4	●	●	●
MA5.0100.01-12	5.92	1.0	M7	12	44	0.13	0.6	0.54	5	3.51	4.9	4	●	●	●
MA5.0100.01-15	6.92	1.0	M7	15	44	0.13	0.6	0.54	5	3.5	4.9	4	●	●	●
MA6.0815.01-15	6.0	0.5-1.5	M7	15	58	0.06	0.8	0.92	6	3.5	5.8	3	●	●	●
MA8.0815.01-25	8.0	0.5-1.5	M9	25	68	0.06	1.0	0.91	8	5.5	7.8	3	●	●	●
MA8.1020.01-25	8.0	1.0-2.0	M10	25	68	0.12	1.0	1.19	8	5.0	7.8	3	●	●	●

Weitere HM Sorten können Sie in der Sortenübersicht im Kapitel "Technische Hinweise" und der Preisliste finden.

Bestellbeispiel:  
für Sorte AL41F:  
MA3.0035.01-4/AL41F

More carbide grades you can find in the grades summary in the chapter "technical instructions" and in the price list.

order example:  
grade AL41F:  
MA3.0035.01-4/AL41F





## MIKROMILL

Nut- und Formzirkularfräsen

groove milling  
by circular interpolation

## Typ MB6 / MB8

metrisches ISO-Feingewinde,  
Teilprofil, innen

metric ISO-fine thread,  
partial profile, internal

ab Gewindegröße M7 x 0,5

starting at thread size M7 x 0,5

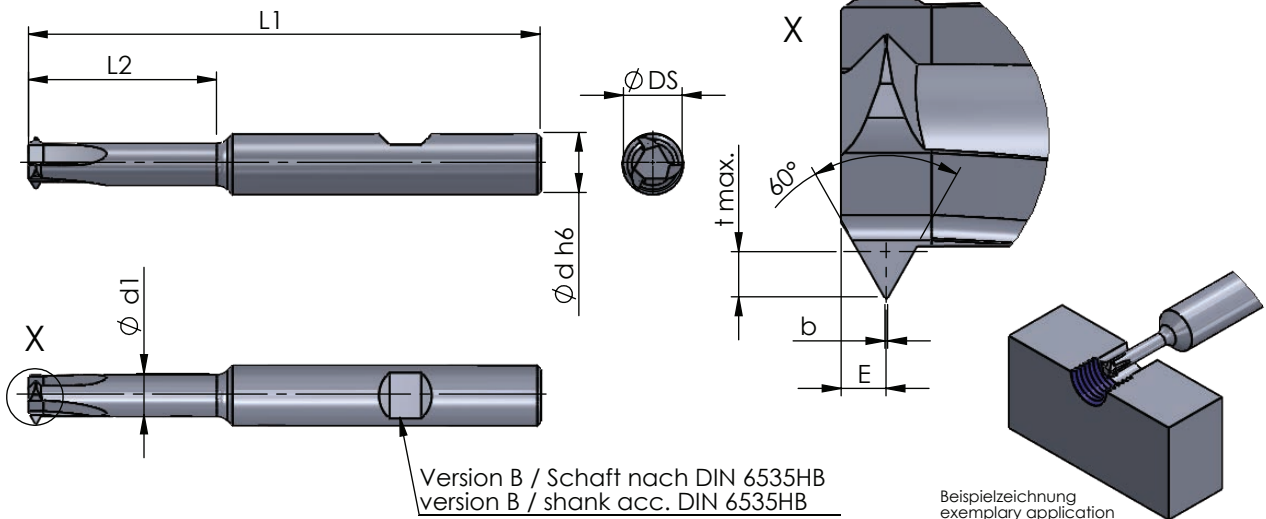

Abmessungen in mm

dimensions in mm

Bestellnummer part number	min. Gewindegröße min. thread size	Steigung P pitch P	L2	L1	b	E	t max.	Ø d h6	Ø d1	Ø DS	Schneidenzahl cutting edge	K10F	AL41F	P18C
												●	●	●
MB6.0815.01-15	M7	0.5-1.5	15	58	0.06	0.8	0.91	6	3.5	5.8	3	●	●	●
MB8.0815.01-25	M9	0.5-1.5	25	68	0.06	1.0	0.91	8	5.5	7.8	3	●	●	●
MB8.1020.01-25	M10	1.0-2.0	25	68	0.12	1.0	1.19	8	5.0	7.8	3	●	●	●

Weitere HM Sorten können Sie in der Sortenübersicht im Kapitel "Technische Hinweise" und der Preisliste finden.

Bestellbeispiel:  
für Sorte AL41F:  
MB6.0815.01-15/AL41F

More carbide grades you can find in the grades summary in the chapter "technical instructions" and in the price list.

order example:  
grade AL41F:  
MB6.0815.01-15/AL41F

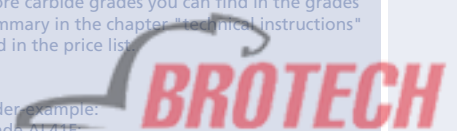

# MIKROMILL

Nut- und Formzirkularfräsen

groove milling  
by circular interpolation

# Typ MA4 / MA6

metrisches ISO-Gewinde,  
Vollprofil, innen

metric ISO-thread,  
full profile, internal

ab Gewindegröße M3 x 0.35

starting at thread size M3 x 0.35

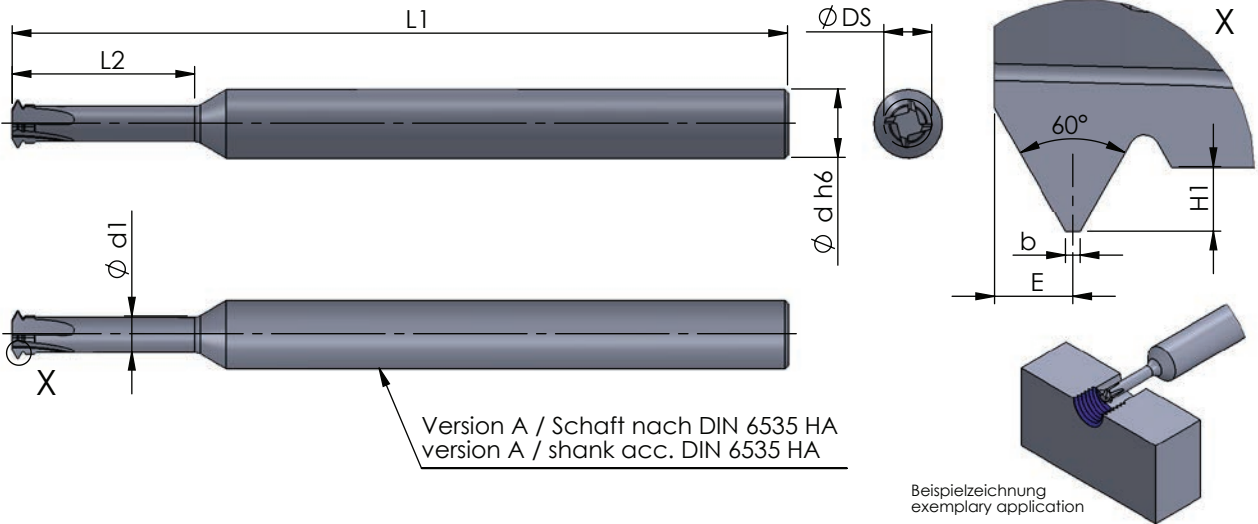

Abmessungen in mm

dimensions in mm

Bestellnummer part number	min. Gewindegröße min. thread size	Steigung P pitch P	L2	L1	b	E	H1	Ø d h6	Ø d1	Ø DS	Schneidenzahl cutting edge	K10F	AL41F	P18C
MA4.VP035-8	M3	0.35	8	44	0.04	0.2	0.19	4	1.4	2.0	3			●
MA4.VP050-8	M3	0.5	8	44	0.06	0.3	0.27	4	1.25	2.0	3			●
MA4.VP060-9	M3.5	0.6	9	44	0.08	0.3	0.33	4	1.4	2.3	3			●
MA6.VP050-10	M4	0.5	10	58	0.06	0.3	0.27	6	2.0	2.8	3			●
MA6.VP070-10	M4	0.7	10	58	0.09	0.4	0.38	6	1.85	2.8	3			●
MA6.VP075-16	M6	0.75	16	68	0.1	0.5	0.41	6	3.1	4.2	4			●
MA6.VP100-16	M6	1.0	16	68	0.12	0.6	0.54	6	2.8	4.2	4			●
MA6.VP125-16	M8	1.25	16	68	0.16	0.75	0.68	6	3.7	5.5	4			●

Weitere HM Sorten können Sie in der Sortenübersicht im Kapitel "Technische Hinweise" und der Preisliste finden.

Bestellbeispiel:  
für Sorte P18C:  
MA4.VP035-8/P18C

More carbide grades you can find in the grades summary in the chapter "technical instructions" and in the price list.

order-example:  
grade P18C:  
MA4.VP035-8/P18C



# MIKROMILL

Nut- und Formzirkularfräsen

groove milling  
by circular interpolation

# Typ MA8 / MA10

metrisches ISO-Gewinde,  
Vollprofil, innen

metric ISO-thread,  
full profile, internal

ab Gewindegröße M8 x 0.75

starting at thread size M8 x 0.75

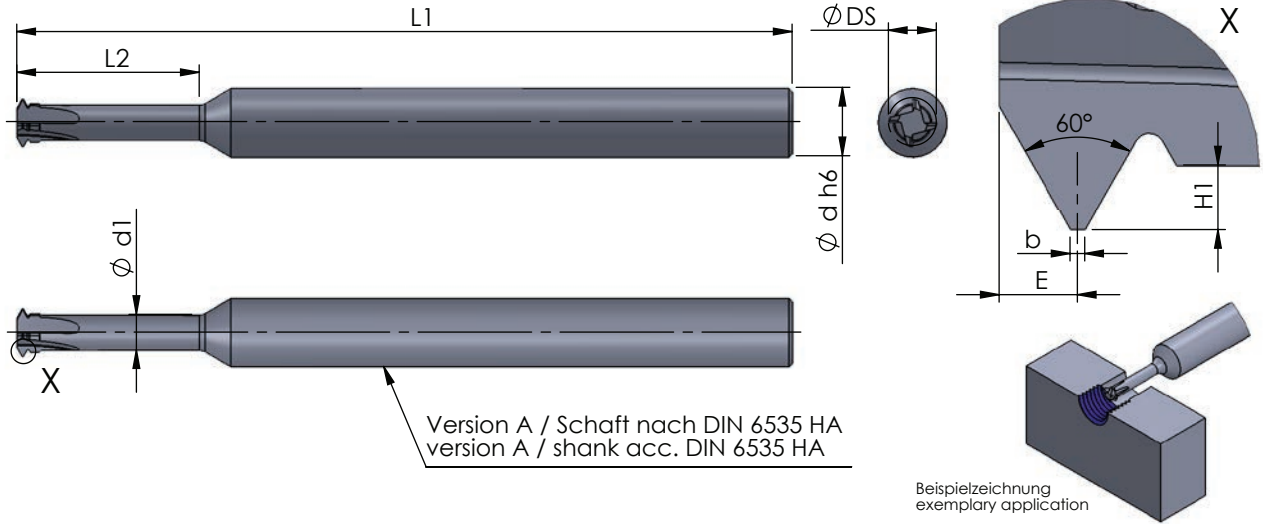

Abmessungen in mm

dimensions in mm

Bestellnummer part number	min. Gewindegröße min. thread size	Steigung P pitch P	L2	L1	b	E	H1	Ø d h6	Ø d1	Ø DS	Schneidenzahl cutting edge	K10F	AL41F	P18C
MA8.VP075-16	M8	0.75	16	69	0.1	0.5	0.41	8	4.3	5.5	4			●
MA8.VP075-20	M10	0.75	20	69	0.1	0.5	0.41	8	5.6	6.8	4			●
MA8.VP100-16	M8	1.0	16	69	0.12	0.6	0.54	8	4.0	5.5	4			●
MA8.VP100-25	M10	1.0	25	79	0.12	0.6	0.54	8	5.4	6.8	4			●
MA8.VP125-16	M8	1.25	16	69	0.16	0.8	0.68	8	3.7	5.5	4			●
MA8.VP150-20	M10	1.5	20	69	0.19	1.0	0.81	8	4.7	6.8	4			●
MA10.VP100-20	M12	1.0	20	69	0.12	0.6	0.54	10	6.3	8.0	4			●
MA10.VP125-30	M12	1.25	30	79	0.16	0.8	0.68	10	6.1	8.0	4			●
MA10.VP175-30	M12	1.75	30	79	0.22	1.0	0.95	10	5.5	8.0	4			●

Weitere HM Sorten können Sie in der Sortenübersicht im Kapitel "Technische Hinweise" und der Preisliste finden.

Bestellbeispiel:  
für Sorte P18C:  
MA8.VP075-16/P18C

More carbide grades you can find in the grades summary in the chapter "technical instructions" and in the price list.

order example:  
grade P18C:  
MA8.VP075-16/P18C

# MIKROMILL

Nut- und Formzirkularfräsen

groove milling  
by circular interpolation

# Impressionen

impressions

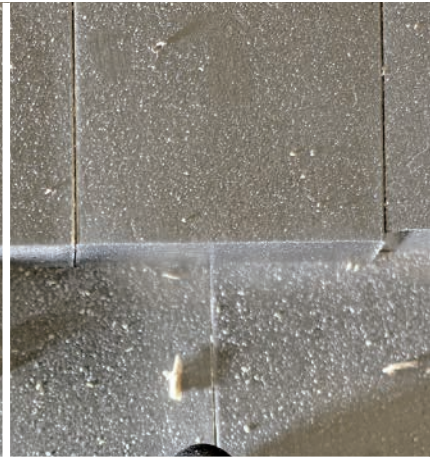

## MIKROMILL

Nut- und Formzirkularfräsen

groove milling  
by circular interpolation

## Technische Hinweise

Grundsätzliche Informationen zum Gewindefräsen

Technical instructions,  
basic informations about thread milling

### Vor- und Nachschnitt

Beim Zirkularfräsen von Gewinden entsteht durch die Steigung ein Vor- und Nachschnitt. Um hier die Verletzung des Gewindepfils so gering wie möglich zu halten muß ein Werkzeug mit einem möglichst kleinen Schneidkreis gewählt werden. Die nachfolgende Skizze zeigt die Verhältnisse bei der Bearbeitung:  
(Grün: Konturverletzung X gering = gut; Rot: Konturverletzung X erheblich = schlecht)

#### Thread profile violation

Thread milling by interpolation causes a profile violation. To keep the violation minimal you should use the cutting circle as small as possible.

The following sketch shows the relations during the process:

(green: profile violation X low = good; red: profile violation X big = bad)

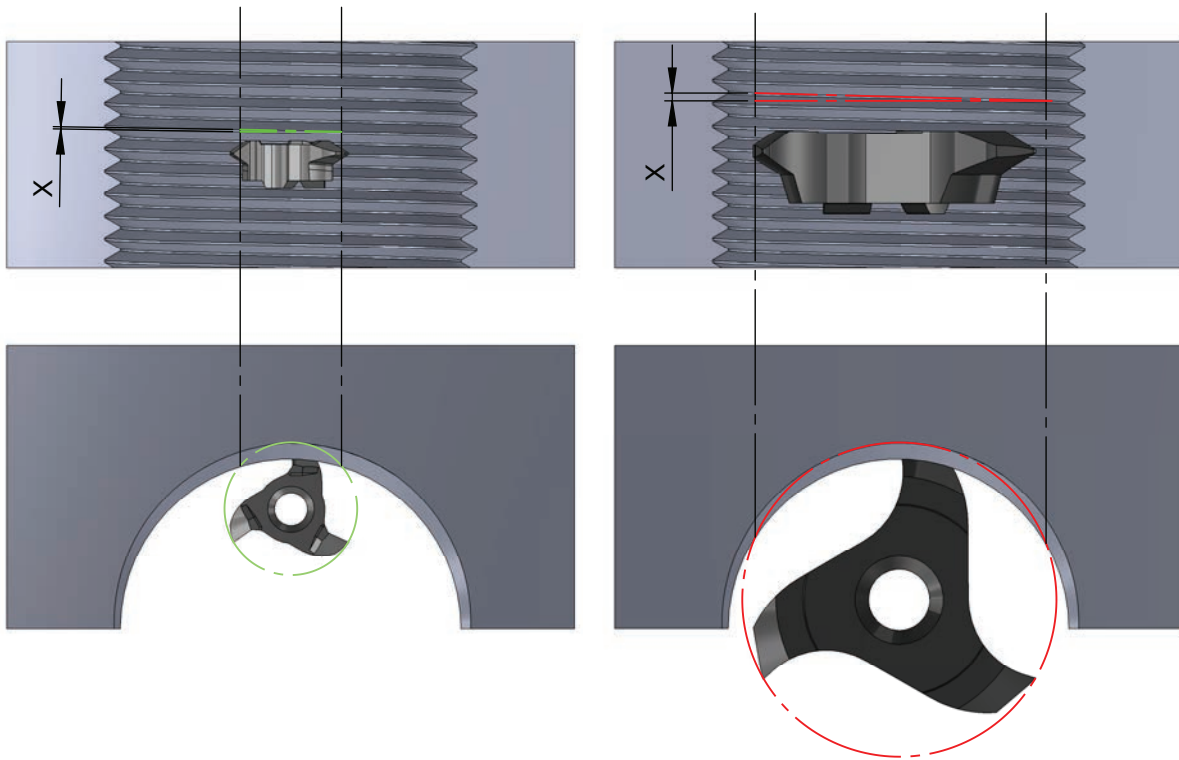

## MIKROMILL

Nut- und Formzirkularfräsen

groove milling  
by circular interpolation

## Technische Hinweise

Grundsätzliche Informationen zum Gewindefräsen

Technical instructions,  
basic informations about thread milling

### Teilprofil

Werkzeuge mit Teilprofil sind Mehrbereichswerkzeuge, d.h. mit diesem Werkzeug können Gewinde mit unterschiedlichen Steigungen hergestellt werden. Dies ist aber nur mit einer kleinen Abweichung vom Normprofil möglich. Abgestimmt ist das Werkzeug auf die kleinste angegebene Steigung, dieses Profil kann ohne Abweichung produziert werden. Alle weiteren Steigungen können ebenfalls produziert werden, hier weicht aber das gefertigte Profil gegenüber der Norm durch eine höhere Gewindetiefe ab. In der Regel ist dies unproblematisch, muß aber gegebenenfalls im Einzelfall genauer betrachtet werden.

#### Partial profile

Tools with partial profile are multi-purpose tools, that means you can process several pitches with one tool. The processed shape has a small difference to the standard profile. Created is that tool for the smallest pitch, this profile depends to the standard.

All other pitches are producible, but only with a small deviation. Normally this causes no problem, but sometimes you have to decide case by case.

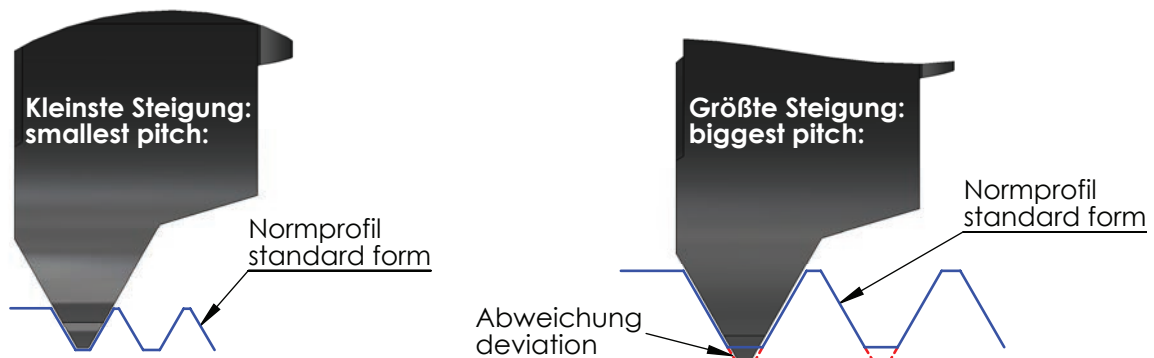

### Auswahlhilfe Mehrbereichswerkzeuge

In der nachfolgenden Tabelle sind alle DÜMMEL - Mehrbereichswerkzeuge aufgeführt. Anhand dieser Tabelle können Sie den jeweiligen Einsatzbereich entnehmen (blau= optimale Kontur, grau= mögliche Konturen):

#### Selection guide multi-purpose-tools

In the following chart are all DÜMMEL - multi-purpose-tools listed. This chart shows the possible area of application (blue= optimal profile; grey= possible profiles):

ab Gewindegröße / starting with thread-size	Steigung (mm)/ pitch (mm)																	
	0,5	0,6	0,7	0,8	0,9	1	1,1	1,2	1,25	1,3	1,4	1,5	1,6	1,7	1,75	1,8	1,9	2
MA/MB 6.0815.01-15	M6,5	M7	M7	M7,5	M8	M8	M8,5	M8,5	M8,5	M8,5	M9	M9						
MA/MB 8.0815.01-25	M8,5	M9	M9,5	M9,5	M10	M10	M10,5	M10,5	M10,5	M11	M11	M11						
MA/MB 8.1020.01-25						M10	M10,5	M10,5	M10,5	M11	M11	M11	M11,5	M11,5	M11,5	M11,5	M11,5	M12

## MIKROMILL

Nut- und Formzirkularfräsen

groove milling  
by circular interpolation

## Technische Hinweise

Hartmetallsorten und Beschichtungen

Technical instructions,  
carbide grades and coatings



### K10F

Universell einsetzbares Feinkornhartmetall mit guter Verschleißfestigkeit. Unbeschichtet geeignet für Anwendungen mit niedrigen und mittleren Schnittgeschwindigkeiten, sowie die Bearbeitung von Nicht-eisenmetallen.

All purpose micrograin carbide with good abrasion resistance. Uncoated for applications with low or medium cutting speeds and machining of non-ferrous materials.

### CBN

Zähe CBN-Sorte für Anwendungen mit niedrigen Schnittgeschwindigkeiten. Geeignet für gehärtete Stähle, unterbrochene Schnitte und Grauguss.

Ductile CBN grade for applications with lower cutting speed. Suitable for hardened steel, interrupted cuts and cast iron.

### CN45F

Universell einsetzbare PVD-TiN-Beschichtung. Diese Allround-Sorte ist für niedrige und mittlere Schnittgeschwindigkeiten mit Einschränkung bei NE-Metallen

PVD-TiN coating - all purpose, all around grade is suitable for low and medium cutting speed with restrictions on non-ferrous materials.

### AL41F

Sehr universell einsetzbare TiAlN-Beschichtung mit hoher Temperaturbeständigkeit bei hoher Härte. Sehr gut geeignet auch für NE-Metalle.

TiAlN coating - very universal with a high resistance to high temperature and hardness. Very suitable also for non-ferrous metals.

### PD2F

Beschichtung für den universellen Einsatz bei niedrigen und mittleren Schnittgeschwindigkeiten.

Coating for universal use with medium and low speed.

### XC2A

Beschichtung mit einer excellenten Warmhärte, Oxidationsbeständigkeit und thermischen Isolationsfähigkeit. Ideal für Hartzerspannung >60HRC

Coating with excellent hot hardness, high oxidation resistance and thermal insulation capacity. Perfect for hard machining >60 HRC.

## MIKROMILL

Nut- und Formzirkularfräsen

groove milling  
by circular interpolation

## Technische Hinweise

Hartmetallsorten und Beschichtungen

Technical instructions,  
carbide grades and coatings

### P01C

Beschichtung für die Bearbeitung in zähen Materialien bei niedrigen und mittleren Schnittgeschwindigkeiten.

Coating for the processing in tough material with medium or low cutting speed



### P03C

Beschichtung für die Bearbeitung von schwer zerspanbaren Materialien. Sehr gut auch für die Trockenbearbeitung geeignet.

Coating for materials which are difficult to machine. Perfect to use for dry machining.

### P07C

Beschichtung für die Bearbeitung von Titan, Edelstahl und Molybdän.

Coating to machine titanium, stainless steel and molybdenum.

### P18C

Universell einsetzbare Hochleistungsschicht mit hoher Oxidationsbeständigkeit, Verschleißfestigkeit und Warmhärte.

Very universal high performance coating with high oxidation resistance, wear resistance and hot hardness resistance.

### NEME

Beschichtung für die Bearbeitung von Aluminium, Al-Legierungen, NE-Metallen und Composite-Werkstoffen.

Coating for machining aluminium, alloys, non-ferrous metals and composite materials.



# MIKROMILL

Nut- und Formzirkularfräsen

groove milling  
by circular interpolation

# Technische Hinweise

Schnittdaten

Technical instructions,  
cutting data



	Werkstoff	Festigkeit	Werkstoff-Nr	Werkstoffbezeichnung	Werkstoff-Nr	
<b>P</b>	Allgemeiner Baustahl	< 800 N/mm2	1.0037	St37-2	1.0570	
	Automatenstahl	< 800 N/mm2	1.0718	9SMnPb28	1.0727	
	Einsatzstahl unlegiert	< 800 N/mm2	1.0401	C15	1.0481	
	Einsatzstahl legiert	< 1000 N/mm2	1.7331	16MnCr5 (EC80)	1.7015	
	Vergütungsstahl unlegiert	< 850 N/mm2	1.0503	C45	1.1191	
	Vergütungsstahl unlegiert	< 1000 N/mm2	1.0601	C60	1.1221	
	Vergütungsstahl legiert	< 800 N/mm2	1.5131	50MnSi4	1.7030	
	Vergütungsstahl legiert	< 1300 N/mm2	1.5755	31NiCr14	1.7033	
	Stahlguss	< 850 N/mm2	0.9650	G-X260Cr27	1.6750	
	Nitrierstahl	< 1000 N/mm2	1.8504	34CrAl6	1.8507	
	Nitrierstahl	< 1200 N/mm2	1.8515	31CrMo12	1.8523	
	Wälzlagerstahl	< 1200 N/mm2	1.3505	100Cr6 (W3)	1.3543	
	Federstahl	< 1200 N/mm2	1.5026	55Si7	1.7176	
	Schnellarbeitsstahl	< 1300 N/mm2	1.3344	S 6-5-3	1.3255	
	Werkzeugstahl für Kaltarbeit	< 1300 N/mm2	1.2312	40CrMnMoS8 6	1.2379	
	Werkzeugstahl für Warmbeit	< 1300 N/mm2	1.2343	X38CrMoV 5 1	1.2767	
	<b>M</b>	Stahl und Stahlguss rostfrei geschwefelt	< 850 N/mm2	1.4305	X8CrNiS18 9	1.4105
		Nichtrostender Stahl, ferritisch	< 750 N/mm2	1.4510	X3CrTi17	1.4528
Nichtrostender Stahl, martensitisch		< 900 N/mm2	1.4034	X46Cr13	1.4116	
Nichtrost. Stahl, ferritisch/martensit.		<1100 N/mm2	1.4313	X3CrNi13-4	1.4028	
Nichtrost. Stahl, austenitisch/ferritisch		< 850 N/mm2	1.4460	X8CrNiMo27 5	1.4821	
Nichtrostender Stahl, austenitisch		< 750 N/mm2	1.4301	X5CrNi18-10	1.4571	
Hitzebeständig		< 1100 N/mm2	1.4747	X80CrNiSi20	1.4876	
<b>K</b>	Grauguss mit Lammellengraphit	100-350N/mm2	0.6010	GG10	0.6025	
	Grauguss mit Lammellengraphit	300-1000N/mm2	0.6030	GG30	0.6045	
	Kugelgraphitguss	300-500N/mm2	0.7040	GGG40	0.7050	
	Kugelgraphitguss	550-800N/mm2	0.7060	GGG60	0.7080	
	Temperguss weis	350-450N/mm2	0.8035	GTW35	0.8045	
	Temperguss weis	500-650N/mm2	0.8055	GTW55	0.8065	
	Temperguss schwarz	350-450N/mm2	0.8135	GTS35	0.8145	
Temperguss schwarz	500-700N/mm2	0.8155	GTS55	0.8170		
<b>N</b>	Aluminium ( unlegiert, niedrig legiert )	< 350 N/mm2	3.0255	Al99,5	3.3308	
	Aluminiumlegierungen < 0,5% Si	< 500 N/mm2	3.0515	AlMn1	3.1355	
	Aluminiumlegierungen 0,5-10% Si	< 400 N/mm2	3.2152	GD-AlSi6Cu4	3.2373	
	Aluminiumlegierungen 10-15% Si	< 400 N/mm2	3.2381	G-AlSi10Mg	3.5562	
	Aluminiumlegierungen > 15% Si	< 400 N/mm2		G-AlSi17Cu4		
	Kupfer ( unlegiert, niedrig legiert )	< 350 N/mm2	2.0060	E-Cu57	2.0090	
	Kupfer-Knetlegierungen	< 700 N/mm2	2.0240	CuZn15	2.0265	
	Kupfer-Sonderlegierungen	< 200 HB	2.0916	CuAl5	2.1525	
	Kupfer-Sonderlegierungen	< 300HB	2.0978	CuAl11Ni6Fe5		
	Kupfer-Sonderlegierungen	> 300 HB	2.1247	CuBe2F125		
	Messing kurzspanend, Bronze, Rotguss	< 600 N/mm2	2.0360	CuZn40 (Ms60)	2.0380	
	Messing langspanend	< 600 N/mm2	2.0335	CuZn36 (Ms63)	2.1293	
	Thermoplaste			Delrin, Hostalen		
	Duroplaste			Ferrozell, Bakelit		
	Faserverstärkte Kunststoffe			GFK (Glasfaserverstärkt )		
	Magnesium und Magnesiumlegierungen	< 850 N/mm2	3.5200	M2, MgMn2	3.5612	
	Graphit			C8000, R8500X		
	Wolfram und Wolframlegierungen			W-NiFe (Densimet W)		
Molybdän und Molybdänlegierungen			Mo , Mo-50Re			
<b>S</b>	Reinnickel		1.3911	RNi24	1.3927	
	Nickellegierungen		1.3912	Ni36 (Invar)	1.3924	
	Nickellegierungen	< 850 N/mm2	2.4360	S-NiCu 30 Fe		
	Nickel-Chromlegierungen		2.4886	SG-NiMo16Cr16W	2.4610	
	Nickel- und Kobaltlegierungen	< 1300 N/mm2	2.4632	NiCr20Co18Ti	2.4631	
	Nickel- und Kobaltlegierungen	< 1300 N/mm2	2.4634	NiCo20Cr15MoAlTi	2.4654	
	Hochwärmefeste Legierungen	< 1300 N/mm2		Hardox 400	1.4939	
	Nickel-Kobalt-(Chrom-)legierungen	< 1400 N/mm2	2.4806	SG-NiCr20Nb, Inconel 82	2.4851	
	Reintitan	< 900 N/mm2	3.7025	Ti99,8	3.7034	
	Titanlegierungen	< 700 N/mm2	3.7114	TiAl5Sn2	3.7174	
	Titanlegierungen	< 1200 N/mm2	3.7164	TiAl5V4	3.7144	
<b>H</b>	Stahl gehärtet	< 45 HRc				
		46-55HRc				
		56-60 HRc				
		61-65 HRc				
	65-70 HRc					



# MIKROMILL

Nut- und Formzirkularfräsen

groove milling  
by circular interpolation

# Technische Hinweise

Schnittdaten

Technical instructions,  
cutting data



Werkstoffbezeichnung	Werkstoff- Nr	Werkstoffbezeichnung	Vc ( m/min. )	fz (mm)	
St52-3	1.0060	St60-2	40-120	0,02 - 0,05	Haupt-Anwendung
45S20	1.0757	46SPb2		0,02 - 0,05	
17Mn4	1.1141	C15E (CK15)		0,02 - 0,05	
13Cr3 (EC60)	1.5919	15CrNi6	0,01 - 0,04		
Ck45	1.0535	C55	0,02 - 0,05		
Ck60	1.0540	C50	0,01 - 0,04		
28Cr4	1.7225	42CrMo4	0,02 - 0,05		
34Cr4	1.3565	48CrMo4	0,007 - 0,03		
GS-20NiCrMo3 7	1.6582	GS-34 CrNiMo 6	0,02 - 0,05		
34AlMo5	1.8509	41CrAlMo7	0,01 - 0,04		
39CrMoV19 3	1.8550	34 CrAlNi 7	0,007 - 0,02		
X192CrMo17	1.3520	100 CrMn 6 (W4)	0,005 - 0,01		
55Cr3	1.7701	51CrMoV4	0,005 - 0,01		
S 18-1-2-5	1.3294	PMH56-5-3-8; ASP30	0,005 - 0,01		
X155CrVMo12 1	1.2316	X38CrMo16; RAMAX	0,005 - 0,01		
X45NiCrMo4	1.2842	90MnCrV8	0,005 - 0,01		
X4CrMoS18	1.4107	GX8CrNi12	0,01 - 0,04		
X105CrCoMo18 2	1.4016	X6Cr17	0,02 - 0,05		
X50CrMoV15	1.4106	X2CrMoSi18-2-1	0,007 - 0,03		
X30Cr13	1.4104	X14CrMoS17	0,007 - 0,03		
X20CrNiSi25 4	1.4462	X2CrNiMoN22-5-3 (Duplex)	0,007 - 0,03		
X6CrNiMoTi17 12 2	1.4449	X3CrNiMo18-12-3	0,007 - 0,03		
X10NiCrAlTi32-21	1.4825	GX25CrNiSi18-9	0,007 - 0,03		
GG25			0,02 - 0,05	Haupt-Anwendung	
GG45			0,02 - 0,05		
GGG50			0,02 - 0,05		
GGG80			0,02 - 0,05		
GTW45			0,02 - 0,05		
GTW65			0,02 - 0,05		
GTS45			0,02 - 0,05		
GTS70			0,02 - 0,05		
Al99,9Mg0,5	3.0256	E-Al H	0,02 - 0,07	Haupt-Anwendung	
AlCuMg2	3.3315	AlMg1	0,02 - 0,07		
GD-AlSi9Mg	3.2134	GD-AlSi5Cu1Mg	0,02 - 0,07		
G-MgAl6	3.2525	S-AlSi12	0,02 - 0,07		
G-AlSi25CuNiMg		G-AlSi21CuNiMg	0,02 - 0,07		
SF-Cu	2.1522	CuSi2Mn	0,02 - 0,07		
CuZn30	2.0321	CuZn37	0,02 - 0,07		
CuSi3Mn		Ampco 8-16	0,02 - 0,07		
		Ampco18-26	0,02 - 0,07		
		Ampco M-4	0,02 - 0,07		
CuZn39Pb2 (Ms58)	2.0410	CuZn44Pb2	0,02 - 0,07	Haupt-Anwendung	
CuCrZr	2.1080	CuSn6Zn6	0,02 - 0,07		
Makrolon, Novodur		Acrylglas, Polystyrol	0,02 - 0,1		
Pertinax		Resopal	0,02 - 0,1		
CFK (Kohlefaserverstärkt)		AFK (Amidfaserverstärkt)	0,02 - 0,07	Haupt-Anwendung	
MgAl6Zn1	3.5812	MgAl8Zn1	0,02 - 0,05		
R8650		Technograph15	0,02 - 0,07		
W-Cu80/20		W93NiFe (DENAL)	0,02 - 0,05		
TZC, TZM		MHC , ODS	0,02 - 0,05		
RNi8	1.3926	RNi12	0,007 - 0,02	Neben-Anwendung	
Ni54	1.3921	Ni49	0,007 - 0,02		
NiCu 30 Fe		Monel 400	0,007 - 0,02		
NiMo16Cr16Ti		Hastelloy C-276	0,007 - 0,02		
NiCr20TiAl		Nimonic 80	0,007 - 0,02		
NiCr19Co14Mo4Ti		Waspaloy	0,007 - 0,02		
X12CrNiMo12	1.4980	X6NiCrTiMoVB25-15-2	0,007 - 0,02		
NiCr23Fe, Inconel 601	2.4667	SG-NiCr19NbMoTi	0,007 - 0,02		
Ti99,7	3.7064	Ti99,5	0,007 - 0,02		
TiAl6V6Sn2	3.7124	TiCu2	0,007 - 0,02		
TiAl6Sn2Zr4Mo2	3.7154	TiAl6Zr5	0,007 - 0,02		
			0,007 - 0,02	Neben-Anwendung	
			0,007 - 0,02		
			0,007 - 0,02		
			-		
			-		

Für das Gewindefräsen kann die Schnittgeschwindigkeiten reduziert werden, da sonst die maximale Drehzahl überschritten wird.

For thread milling the cutting speed can be reduced, because the maximum speed is reached.





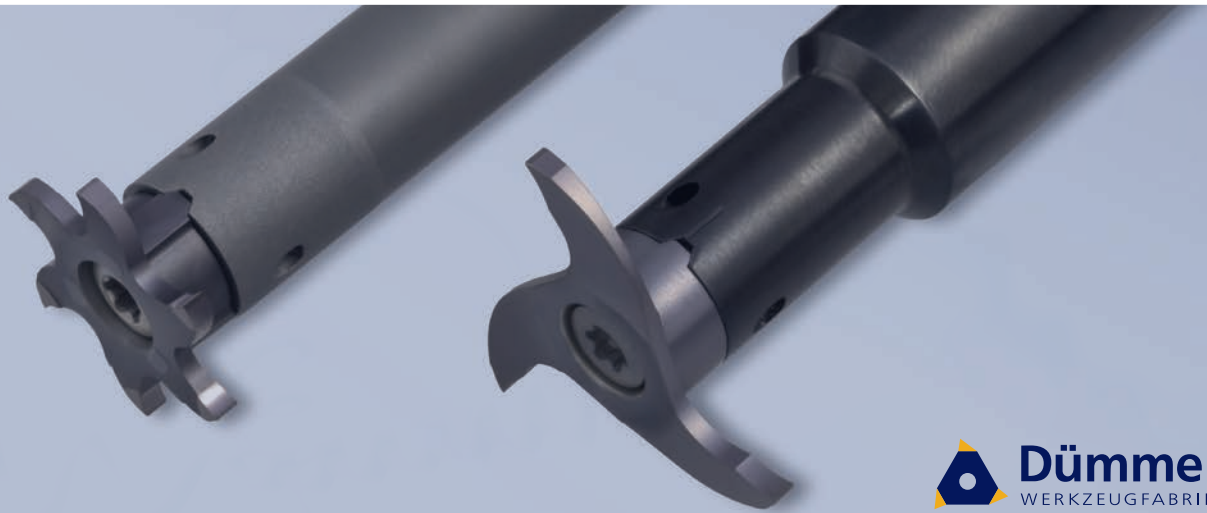

 **Dümmel**<sup>®</sup>  
WERKZEUGFABRIK

**MINIMILL**



**Nut- und Formzirkularfräsen drei- und sechsschneidig  
ab Ø 10 mm**

**Groove milling by circular interpolation with  
three and six cutting edges starting at Ø 10 mm**

 **BROTECH**

## MINIMILL

Nut- und Formzirkularfräsen

groove milling by circular interpolation

## Übersicht

summary



Allgemeine Beschreibung

general instructions

... 341



**Frälerschaft mit innerer Kühlmittelzufuhr**

**milling shank with through coolant**

**Maße dimensions**

**Seite page**

<b>Typ ZH10</b>	Frälerschaft Stahl	milling shank steel	D min. 10	... 342
<b>Typ ZH10</b>	Frälerschaft Hartmetall	milling shank carbide	D min. 10	... 343
<b>Typ ZH14</b>	Frälerschaft Stahl	milling shank steel	D min. 14	... 344
<b>Typ ZH14</b>	Frälerschaft Hartmetall	milling shank carbide	D min. 14	... 345
<b>Typ ZH18</b>	Frälerschaft Stahl	milling shank steel	D min. 18	... 346
<b>Typ ZH18</b>	Frälerschaft Hartmetall	milling shank carbide	D min. 18	... 347
<b>Typ ZH22</b>	Frälerschaft Stahl	milling shank steel	D min. 22	... 348
<b>Typ ZH22</b>	Frälerschaft Hartmetall	milling shank carbide	D min. 22	... 349
<b>Typ ZH28</b>	Frälerschaft Stahl	milling shank steel	D min. 25	... 350
<b>Typ ZH28</b>	Frälerschaft Hartmetall	milling shank carbide	D min. 25	... 351
<b>Typ ZH28</b>	Frälerschaft Schwermetall	milling shank heavy metal	D min. 28	... 352
<b>Typ ZH33</b>	Frälerschaft Hartmetall	milling shank carbide	D min. 28	... 353

## MINIMILL

Nut- und Formzirkularfräsen

groove milling by circular interpolation

## Übersicht

summary



**Schneideinsatz  
Nutfräsen**

**inserts  
groove milling**

**Maße  
dimensions**

**Seite  
page**

<b>Typ Z10</b>	Sicherungsringe DIN 471/472 und Nutfräsen allgemein	for circlips DIN 471/472, groove milling general use	D min. 10 t max. = 1.5	... 355
<b>Typ Z12</b>	Sicherungsringe DIN 471/472 und Nutfräsen allgemein	for circlips DIN 471/472, groove milling general use	D min. 12 t max. = 2.5	... 356
<b>Typ Z612 / Z612.X</b>	Nutfräsen allgemein	groove milling general use	D min. 12 t max. = 2	... 357
<b>Typ Z14</b>	Nutfräsen allgemein	groove milling general use	D min. 14 t max. = 2.5	... 358
<b>Typ Z16</b>	Nutfräsen allgemein	groove milling general use	D min. 16 t max. = 3.5	... 359
<b>Typ Z616 / Z616.X</b>	Nutfräsen allgemein	groove milling general use	D min. 16 t max. = 3.5	... 360
<b>Typ Z18</b>	Sicherungsringe DIN 471/472 und Nutfräsen allgemein	for circlips DIN 471/472, groove milling general use	D min. 18 t max. ≤ 3.5	... 361
<b>Typ Z618</b>	Sicherungsringe DIN 471/472	for circlips DIN 471/472	D min. 18 t max. = 4	... 363
<b>Typ Z618 / Z618.X / Z620 / Z620.X</b>	Nutfräsen allgemein	groove milling general use	D min. 18 / 20 t max. = 4 / 5	... 364
<b>Typ Z22</b>	Sicherungsringe DIN 471/472 und Nutfräsen allgemein	for circlips DIN 471/472, groove milling general use	D min. 22 t max. ≤ 4.5	... 365
<b>Typ Z22</b>	Sicherungsringe DIN 471/472 mit Nutaußenkantenfasung	for circlips DIN 471/472 with chamfer	D min. 22	... 367
<b>Typ Z622 / Z622.X</b>	Nutfräsen allgemein	groove milling general use	D min. 22 t max. = 4.5	... 368
<b>Typ Z25</b>	Nutfräsen allgemein	groove milling general use	D min. 25 t max. = 5.0	... 369
<b>Typ Z625.X</b>	Nutfräsen allgemein	groove milling general use	D min. 25 t max. = 5.0	... 370
<b>Typ Z28</b>	Nutfräsen allgemein	groove milling general use	D min. 28 t max. = 6.5	... 371
<b>Typ Z28</b>	Nutfräsen allgemein	groove milling general use	D min. 28.3 t max. = 9.3	... 372
<b>Typ Z628 / Z628.X</b>	Sicherungsringe DIN 471/472 und Nutfräsen allgemein	for circlips DIN 471/472, groove milling general use	D min. 28 t max. = 6.5	... 373

↳ ...

## MINIMILL

Nut- und Formzirkularfräsen

groove milling by circular interpolation

## Übersicht

summary

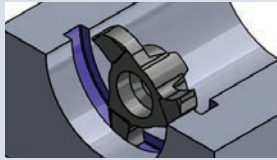

Schneideinsatz  
Nutfräsen

inserts  
groove milling

Maße  
dimensions

Seite  
page

... ↴

	<b>Typ Z628</b>	Nutfräsen allgemein	groove milling general use	D min. 28 t max. = 9.3	... 374
	<b>Typ Z32</b>	Nutfräsen allgemein	groove milling general use	D min. 32 t max. = 8.5	... 375
	<b>Typ Z33</b>	Nutfräsen allgemein	groove milling general use	D min. 33 / 33.9 t max. = 10 / 12	... 376
	<b>Typ Z635 / Z635.X</b>	Nutfräsen allgemein	groove milling general use	D min. 35 t max. = 10	... 377
	<b>Typ Z637 / Z637.X / Z640</b>	Nutfräsen allgemein	groove milling general use	D min. 37 / 40 t max. = 12 / 13.5	... 378
	<b>Typ Z637 / Z640</b>	Nutfräsen, Trennfräsen und Schlitzfräsen, b = 0.4 - 0.8 mm	for groove and keyway milling b = 0.4 - 0.8 mm	D min. 37 / 40 t max. = 12 / 13.5	... 379
	<b>Typ Z12</b>	Vollradius	full radius	D min. 12 t max. = 2.5	... 380
	<b>Typ Z16</b>	Vollradius	full radius	D min. 16 t max. = 3.5	... 381
	<b>Typ Z18</b>	Vollradius	full radius	D min. 18 t max. = 3.5	... 382
	<b>Typ Z22</b>	Vollradius	full radius	D min. 22 t max. = 4,5	... 383

## MINIMILL

Nut- und Formzirkularfräsen

groove milling by circular interpolation

## Übersicht

summary



**Schneideinsatz  
Gewindefräsen**

**inserts  
thread milling**

**Maße  
dimensions**

**Seite  
page**

<b>Typ Z610</b>	metrisches ISO-Gewinde, Teilprofil, innen	metric ISO-thread, partial profile, internal	ab / starting at M12 x 1.0	... 385
<b>Typ Z10</b>	metrisches ISO-Gewinde, Vollprofil, innen	metric ISO-thread, full profile, internal	ab / starting at M12 x 0.75	... 386
<b>Typ Z12</b>	metrisches ISO-Gewinde, Teilprofil, innen	metric ISO-thread, partial profile, internal	ab / starting at M14 x 1.0	... 387
<b>Typ Z614</b>	metrisches ISO-Gewinde, Teilprofil, innen	metric ISO-thread, partial profile, internal	ab / starting at M16 x 1.0	... 388
<b>Typ Z14</b>	metrisches ISO-Gewinde, Vollprofil, innen	metric ISO-thread, full profile, internal	ab / starting at M16 x 1.0	... 389
<b>Typ Z16</b>	metrisches ISO-Gewinde, Teilprofil, innen	metric ISO-thread, partial profile, internal	ab / starting at M18 x 1.0	... 390
<b>Typ Z18</b>	metrisches ISO-Gewinde, Teilprofil, innen	metric ISO-thread, partial profile, internal	ab / starting at M22 x 1.0	... 391
<b>Typ Z618</b>	metrisches ISO-Gewinde, Teilprofil, innen	metric ISO-thread, partial profile, internal	ab / starting at M22 x 1.0	... 392
<b>Typ Z18</b>	metrisches ISO-Gewinde, Vollprofil, innen	metric ISO-thread, full profile, internal	ab / starting at M22 x 1.5	... 393
<b>Typ Z618</b>	metrisches ISO-Gewinde, Vollprofil, innen	metric ISO-thread, full profile, internal	ab / starting at M22 x 1,5	... 394
<b>Typ Z22</b>	metrisches ISO-Gewinde, Teilprofil, innen	metric ISO-thread, partial profile, internal	ab / starting at M27 x 1.0	... 395
<b>Typ Z622</b>	metrisches ISO-Gewinde, Teilprofil, innen	metric ISO-thread, partial profile, internal	ab / starting at M27 x 1.0	... 396
<b>Typ Z22</b>	metrisches ISO-Gewinde, Vollprofil, innen	metric ISO-thread, full profile, internal	ab / starting at M24 x 1.5	... 397
<b>Typ Z622</b>	metrisches ISO-Gewinde, Vollprofil, innen	metric ISO-thread, full profile, internal	ab / starting at M24 x 1.5	... 398
<b>Typ Z28</b>	metrisches ISO-Gewinde, Teilprofil, innen	metric ISO-thread, partial profile, internal	ab / starting at M33 x 1.0	... 399
<b>Typ Z628</b>	metrisches ISO-Gewinde, Teilprofil, innen	metric ISO-thread, partial profile, internal	ab / starting at M33 x 1.5	... 400
<b>Typ Z622</b>	metrisches ISO-Gewinde, Vollprofil, außen	metric ISO-thread, full profile, external	Steigung 1.5 - 4.0 pitch 1.5 - 4.0	... 401

↳ ...



## MINIMILL

Nut- und Formzirkularfräsen

groove milling by circular interpolation

## Übersicht

summary



**Schneideinsatz  
Gewindefräsen**

**inserts  
thread milling**

**Maße  
dimensions**

**Seite  
page**

... ↴

<b>Typ Z12</b>	Whitworth- Gewinde Vollprofil, innen	Whitworth thread full profile, internal	ab / starting at G $\frac{3}{8}$ "	... 402
<b>Typ Z614</b>	Whitworth- Gewinde Vollprofil, innen	Whitworth thread full profile, internal	ab / starting at G $\frac{3}{4}$ "	... 403
<b>Typ Z16</b>	Whitworth- Gewinde Vollprofil, innen	Whitworth thread full profile, internal	ab / starting at G $\frac{5}{8}$ "	... 404
<b>Typ Z18</b>	Whitworth- Gewinde Vollprofil, innen	Whitworth thread full profile, internal	ab / starting at G $\frac{3}{4}$ "	... 405
<b>Typ Z22</b>	Whitworth- Gewinde Vollprofil, innen	Whitworth thread full profile, internal	ab / starting at G 1"	... 406
<b>Typ Z622</b>	Whitworth- Gewinde Vollprofil, innen	Whitworth thread full profile, internal	ab / starting at G 1"	... 407



**Schneideinsatz  
Fasen**

**inserts  
chamfering**

**Maße  
dimensions**

**Seite  
page**

<b>Typ Z10 / Z12</b>	Vorwärts- und Rückwärtsfasen	forward & backward chamfering	D min. 10 / 12	... 408
<b>Typ Z610</b>	Vorwärts- und Rückwärtsfasen	forward & backward chamfering	D min. 10	... 409
<b>Typ Z614</b>	Vorwärts- und Rückwärtsfasen	forward & backward chamfering	D min. 14	... 410
<b>Typ Z16</b>	Vorwärts- und Rückwärtsfasen	forward & backward chamfering	D min. 16	... 411
<b>Typ Z18</b>	Vorwärts- und Rückwärtsfasen	forward & backward chamfering	D min. 15	... 412
<b>Typ Z18</b>	Vorwärts- und Rückwärtsfasen mit Radius	forward & backward chamfering with radius	D min. 18	... 413
<b>Typ Z22</b>	Vorwärts- und Rückwärtsfasen	forward & backward chamfering	D min. 22	... 414
<b>Typ Z618 / Z622 / Z628</b>	Vorwärts- und Rückwärtsfasen	forward & backward chamfering	D min. 15/18/ 22 /28	... 415

## MINIMILL

Nut- und Formzirkularfräsen

groove milling by circular interpolation

## Übersicht

summary

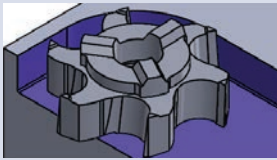

**Schneideinsatz  
Stirn-/Planfräsen**

**inserts  
face milling**

**Maße  
dimensions**

**Seite  
page**

**Typ Z620 / Z628**

Stirn- und Planfräsen

face milling

D min. 20 / 28

... 416



**Sets Minimill  
Halter und Schneiden**

**sets Minimill  
toolholder and inserts**

**Maße  
dimensions**

**Seite  
page**

**SET-MINI-MILLZ12**

Auswahl Z12

selection Z12

D min. 12

... 417

**SET-MINI-MILLZ18**

Auswahl Z18

selection Z18

D min. 18

... 417

**SET-MINI-MILLZ22**

Auswahl Z622 / Z22

selection Z622 / Z22

D min. 22

... 418

**SET-MINI-MILLZ637**

Auswahl Z637

selection Z637

D min. 37

... 418

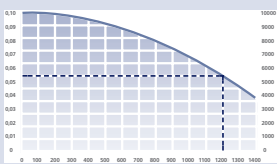

**Technische Hinweise**

**Technical Instructions**

**Seite  
page**

Grundsätzliche Informationen zum Gewindefräsen

basic informations about thread milling

... 420

Hartmetallsorten und Beschichtungen

Carbide grades and coatings

...423

Ermittlung der Schnittdaten

evaluation of the cutting data

...425

Schnittdaten

cutting data

... 427

## MINIMILL

Nut- und Formzirkularfräsen

groove milling by circular interpolation

## Allgemeine Beschreibung

general instruction

Die austauschbaren drei- und sechsschneidigen HM-Schneiden verfügen über die bewährte Dreirippenverzahnung, welche einen bestmöglichen Rundlauf garantieren. Die große Auswahl an Standard-Schneideinsätzen sind, ebenso wie die Fräterschäfte, in Stahl und Hartmetall, ab Lager lieferbar.

The indexible carbide inserts are clamped with the proven interface. All inserts and milling shanks are available on stock.

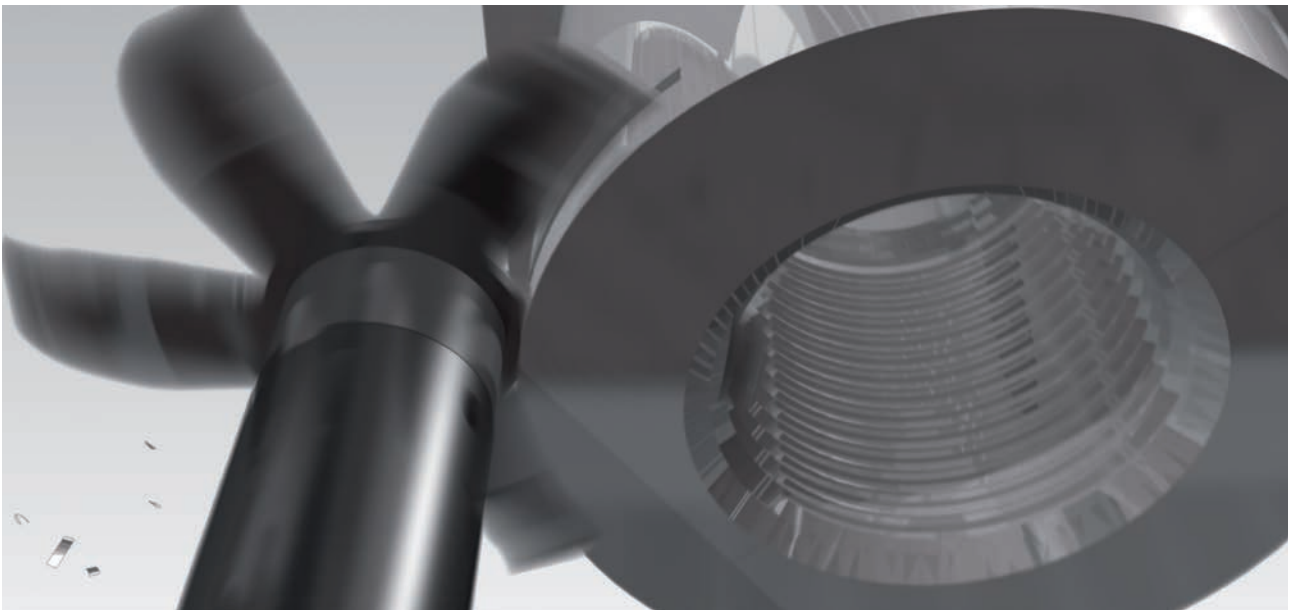
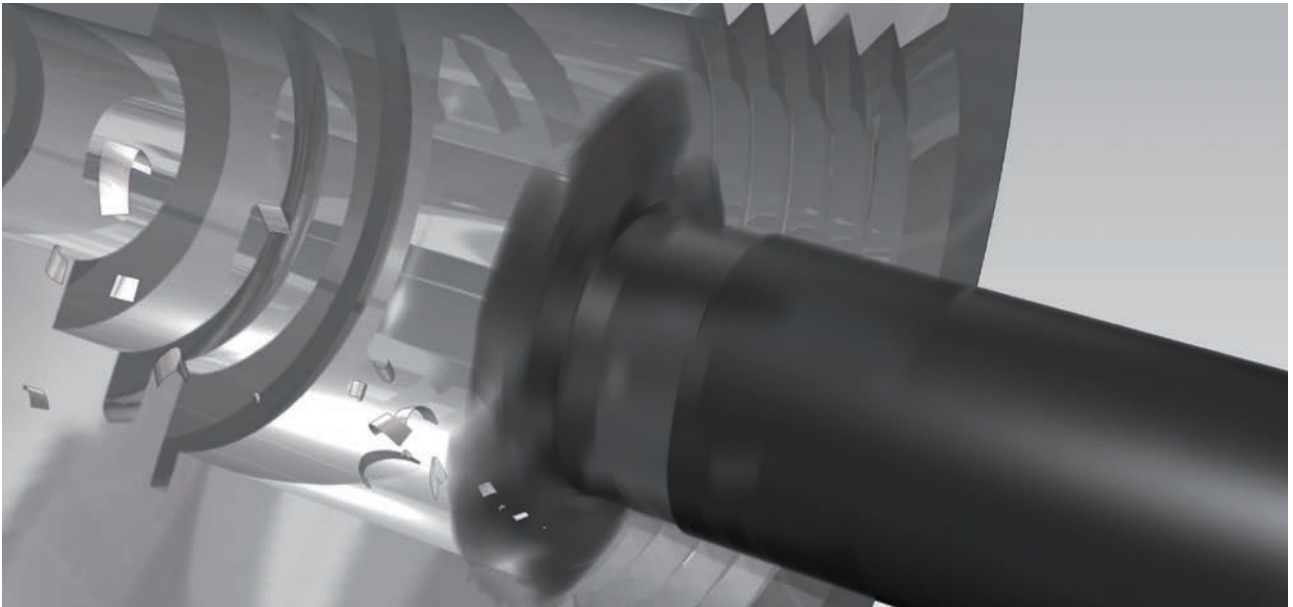

# MINIMILL

Nut- und Formzirkularfräsen

groove milling by circular interpolation

# Typ ZH10

Fräseschaft Stahl

milling shank steel

D min. 10 mm

D min. 10 mm

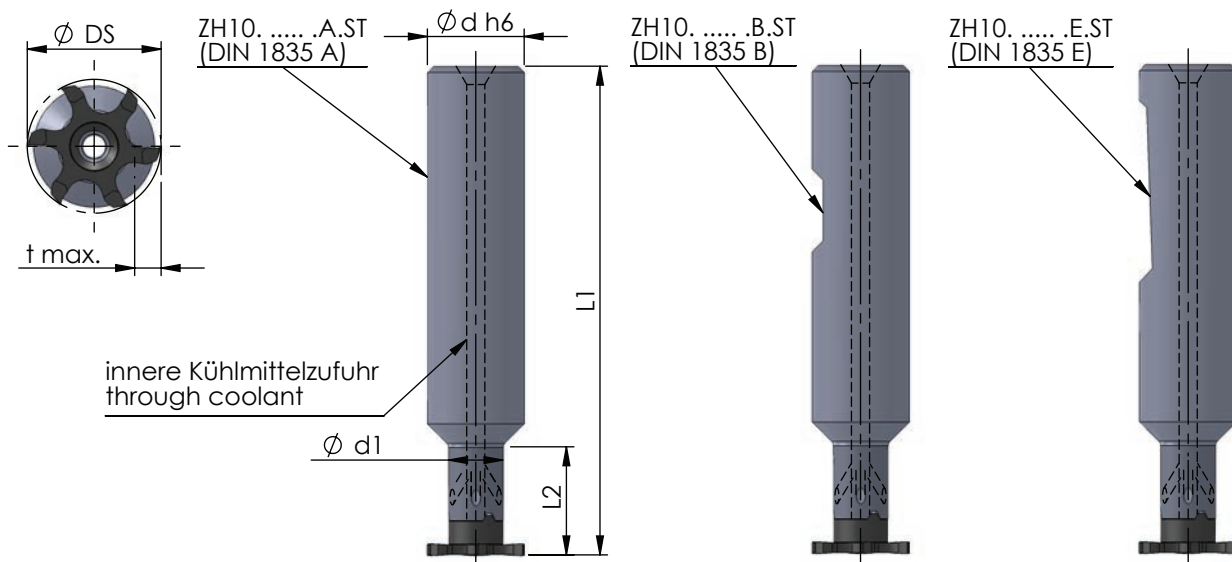

Abmessungen und Beschreibungen gelten für alle Varianten

dimensions and descriptions are valid for all versions

Abmessungen in mm

dimensions in mm



Bestellnummer part number	$\varnothing d h6$	$d1$	$L1$	$L2$	Typ: $t max./$ Schneidkreis- $\varnothing DS$	Spannschraube screw	Schraubenschlüssel wrench	Anzugs- drehmoment torque	für Schneideinsatz for insert
ZH10.1006.15.A.ST	10	6	60	15	Z10: 1.5 / 9.7	M2.6-MM	T 8F	2.0 Nm	Z10...
ZH10.1606.12.A.ST / ...B.ST / ...E.ST	16	6	80	12	Z12: 2.5 / 11.7				Z610...
					Z612: 2 / 11.7				Z612...

Bestellbeispiel:  
ZH10.1606.12.A.ST



**MINIMILL**

Nut- und Formzirkularfräsen

groove milling by circular interpolation

**Typ ZH10**

Frälerschaft Hartmetall

D min. 10 mm

milling shank carbide

D min. 10 mm

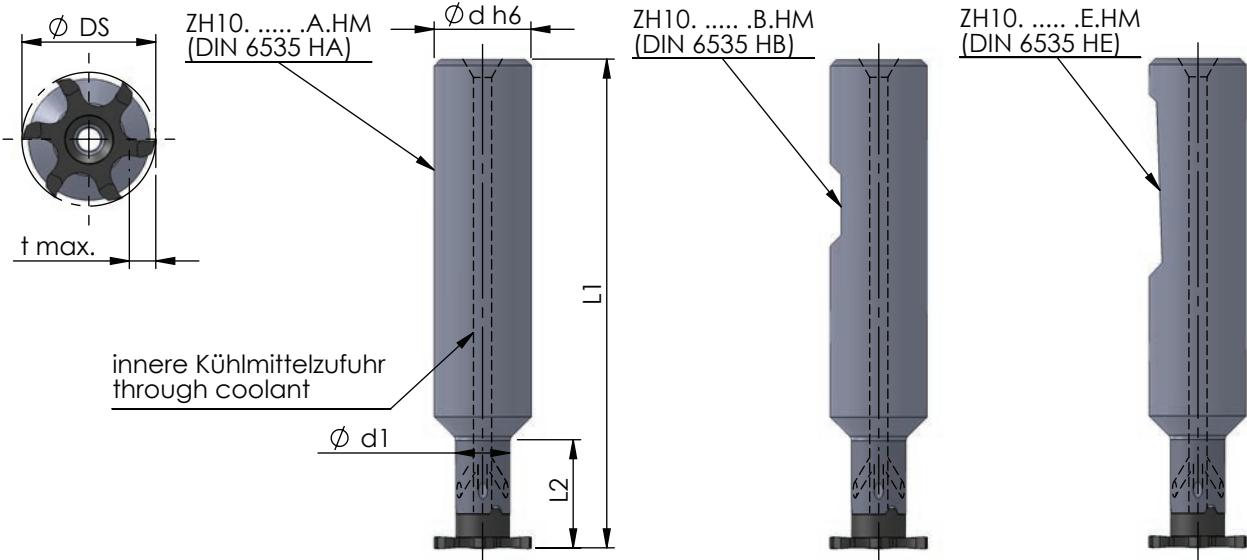

Abmessungen und Beschreibungen gelten für alle Varianten

dimensions and descriptions are valid for all versions

Abmessungen in mm

dimensions in mm

Bestellnummer part number	$\varnothing d h6$	$\varnothing d$ (inch)	$\varnothing d1$	L1	L2	Typ: t max./ Schneidkreis- $\varnothing DS$	Spannschraube screw	Schraubenschlüssel wrench	Anzugs- drehmoment torque	für Schneideinsatz for insert
neu ZH10.1206.21.A.HM /...B.HM /...E.HM	12	6	80	21						
ZH10.U1206.21.A.HM /...B.HM	12.7	1/2"	6	80	21					
neu ZH10.1206.30.A.HM /...B.HM /...E.HM	12	6	90	30						
ZH10.U1206.30.A.HM /...B.HM	12.7	1/2"	6	90	30					
neu ZH10.1206.42.A.HM /...B.HM /...E.HM	12	6	100	42		Z10: 1.5 / 9.7 Z12: 2.5 / 11.7 Z612: 2 / 11.7	M2.6-MM	T 8F	2.0 Nm	Z10... Z12... Z610... Z612...
ZH10.U1206.42.A.HM /...B.HM	12.7	1/2"	6	100	42					
neu ZH10.1207.30.A.HM /...B.HM /...E.HM	12	7.3	90	30		t max. reduziert				
ZH10.U1207.30.A.HM /...B.HM	12.7	1/2"	7.3	90	30	t max. reduziert				
ZH10.1607.25.A.HM /...B.HM /...E.HM	16	7.3	100	25		t max. reduced				

Hinweis:  
Hartmetall-Frälerschäfte mit beschädigter  
Schneidplattenaufnahme können durch unseren  
Reparaturservice instand gesetzt werden.

Bestellbeispiel:  
ZH10.1607.25.A.HM

note:  
carbide-toolholder with damaged seating can be  
repaired by Dümmel.

order example:  
ZH10.1607.25.A.HM



# MINIMILL

Nut- und Formzirkularfräsen

groove milling by circular interpolation

# Typ ZH14

Fräferschaft Stahl

milling shank steel

D min. 14 mm

D min. 14 mm

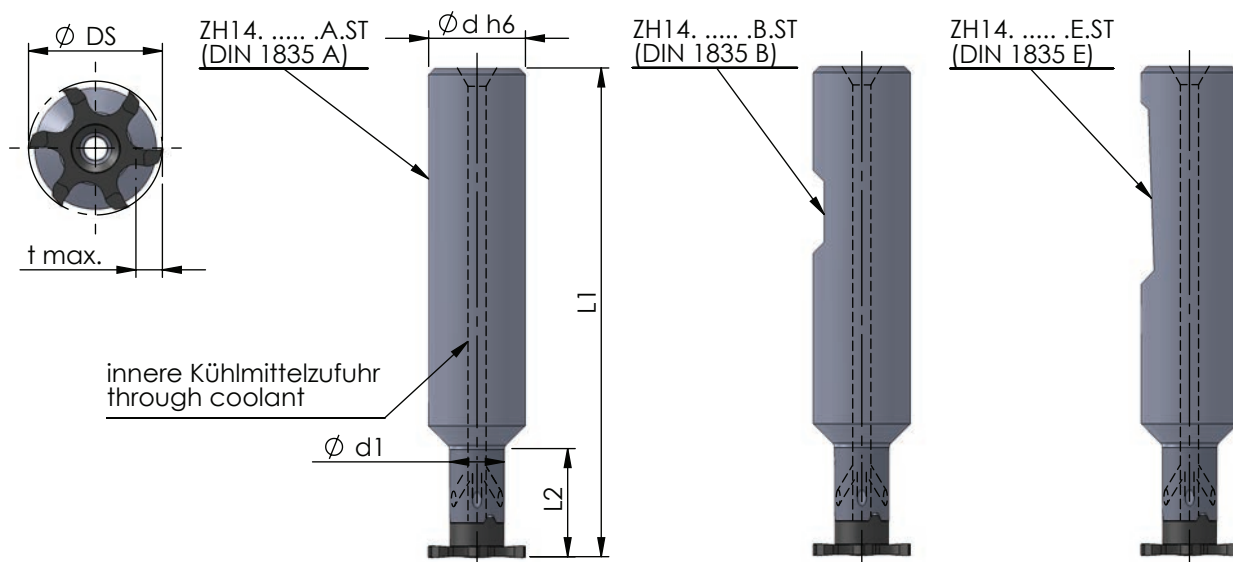

Abmessungen und Beschreibungen gelten für alle Varianten

dimensions and descriptions are valid for all versions

Abmessungen in mm

dimensions in mm

Bestellnummer part number	$\phi d h6$	d1	L1	L2	Typ: t max./ Schneidkreis- $\phi DS$	Spannschraube screw	Schraubenschlüssel wrench	Anzugs- drehmoment torque	für Schneideinsatz for insert
ZH14.1008.17.A.ST	10	8	60	17	Z14: 2.5 / 13.7	M3.5-MM	T 10F	3.5 Nm	Z14...
ZH14.1308.25.A.ST	13	8	70	25	Z16: 3.5 / 15.7				Z16...
ZH14.1608.16.A.ST /...B.ST /...E.ST	16	8	80	16	Z616: 2.5 / 15.7				Z616...

Bestellbeispiel:  
ZH14.1608.16.A.ST





**MINIMILL**

Nut- und Formzirkularfräsen

groove milling by circular interpolation

**Typ ZH14**

Frälerschaft Hartmetall

D min. 14 mm

milling shank carbide

D min. 14 mm

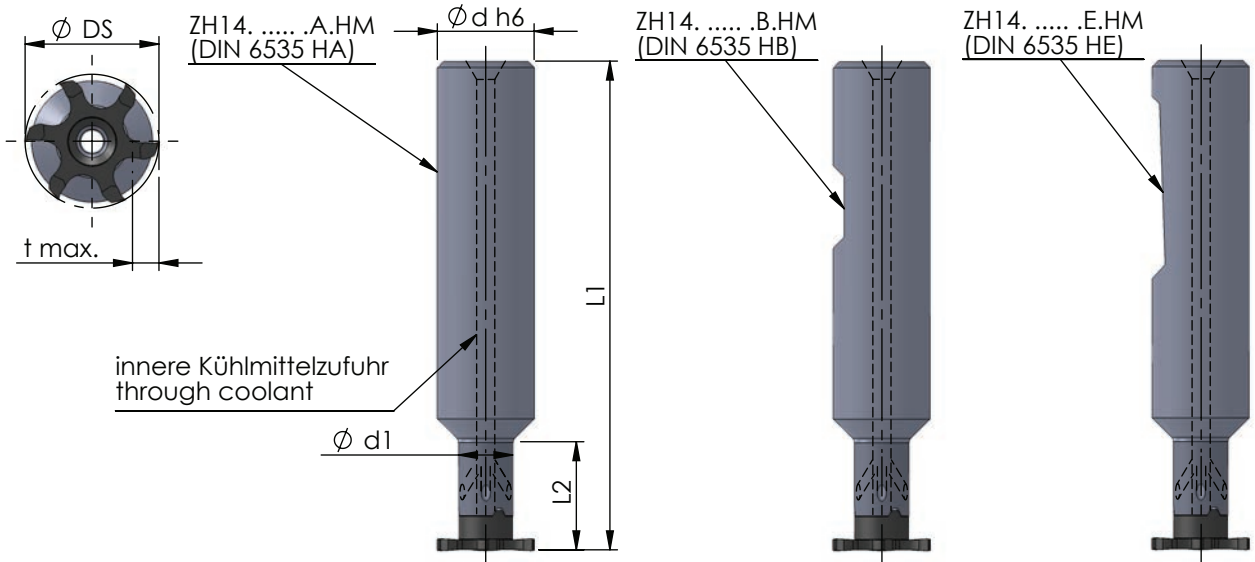

Abmessungen und Beschreibungen gelten für alle Varianten

dimensions and descriptions are valid for all versions

Abmessungen in mm

dimensions in mm

Bestellnummer part number	Ø d h6	Ø d (inch)	Ø d1	L1	L2	Typ: t max./ Schneidkreis-Ø DS	Spannschraube screw	Schraubenschlüssel wrench	Anzugs- drehmoment torque	für Schneideinsatz for insert
neu ZH14.1208.29.A.HM /...B.HM /...E.HM	12	8	95	29						
ZH14.U1208.29.A.HM /...B.HM	12.7	1/2"	8	95	29					
neu ZH14.1208.42.A.HM /...B.HM /...E.HM	12	8	110	42						
ZH14.U1208.42.A.HM /...B.HM	12.7	1/2"	8	110	42					
neu ZH14.1208.56.A.HM /...B.HM /...E.HM	12	8	120	56		Z14: 2.5 / 13.7 Z16: 3.5 / 15.7 Z616: 2.5 / 15.7	M3.5-MM	T 10F	3.5 Nm	Z14... Z16... Z614... Z616...
ZH14.U1208.56.A.HM /...B.HM	12.7	1/2"	8	120	56					
neu ZH14.1209.42.A.HM /...B.HM /...E.HM	12	9.5	110	42		t max. reduziert				
ZH14.U1209.42.A.HM /...B.HM	12.7	1/2"	9.5	110	42	t max. reduziert				
neu ZH14.1609.33.A.HM /...B.HM /...E.HM	16	9.5	110	33		t max. reduced				

Hinweis:  
Hartmetall-Frälerschäfte mit beschädigter  
Schneidplattenaufnahme können durch unseren  
Reparaturservice instand gesetzt werden.

Bestellbeispiel:  
ZH14.1609.33.A.HM

note:  
carbide-toolholder with damaged seating can be  
repaired by Dümmel.

order example:  
ZH14.1609.33.A.HM



# MINIMILL

Nut- und Formzirkularfräsen

groove milling by circular interpolation

# Typ ZH18

Fräferschaft Stahl

milling shank steel

D min. 18 mm

D min. 18 mm

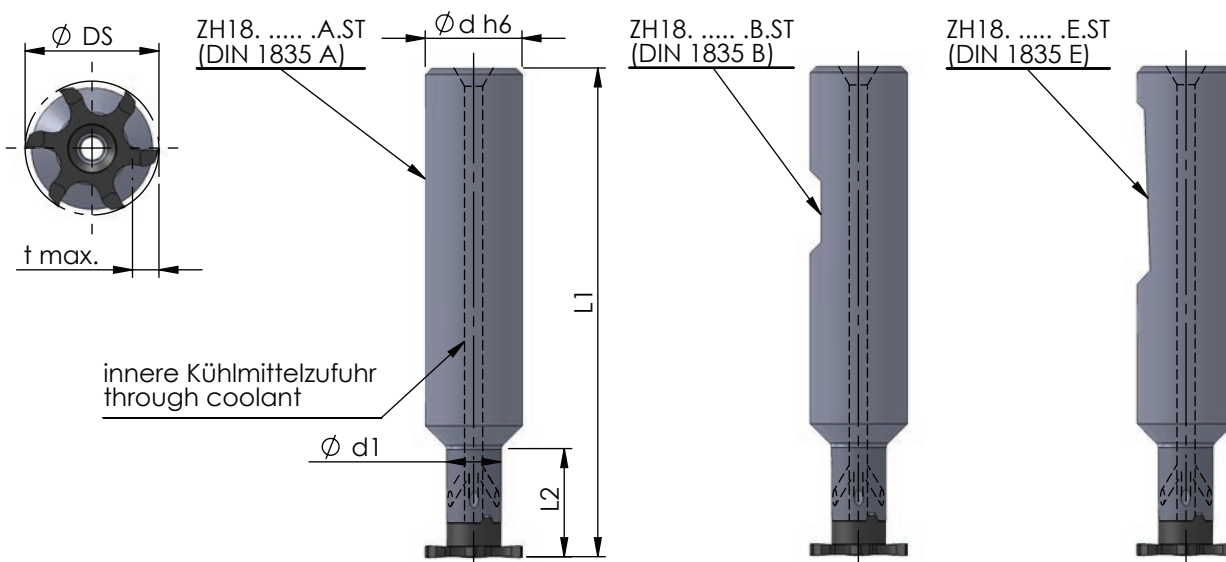

Abmessungen und Beschreibungen gelten für alle Varianten

dimensions and descriptions are valid for all versions

Abmessungen in mm

dimensions in mm

Bestellnummer part number					Typ: t max./ Schneidkreis- $\varnothing DS$	Spannschraube screw	Schraubenschlüssel wrench	Anzugs- drehmoment torque	für Schneideinsatz for insert
	$\varnothing d_{h6}$	$d_1$	L1	L2					
ZH18.1009.17.A.ST	10	9	60	17	Z18: 3.5 / 17.7 Z618: 4 / 17.7 Z620: 5 / 19.7	M4-MM	T 15F	4.5 Nm	Z18... Z618... Z620...
ZH18.1309.25.A.ST	13	9	70	25					
ZH18.1609.18.A.ST /...B.ST /...E.ST	16	9	80	18					

Bestellbeispiel:  
ZH18.1609.18.A.ST







**MINIMILL**

Nut- und Formzirkularfräsen

groove milling by circular interpolation

**Typ ZH18**

Frälerschaft Hartmetall

D min. 18 mm

milling shank carbide

D min. 18 mm

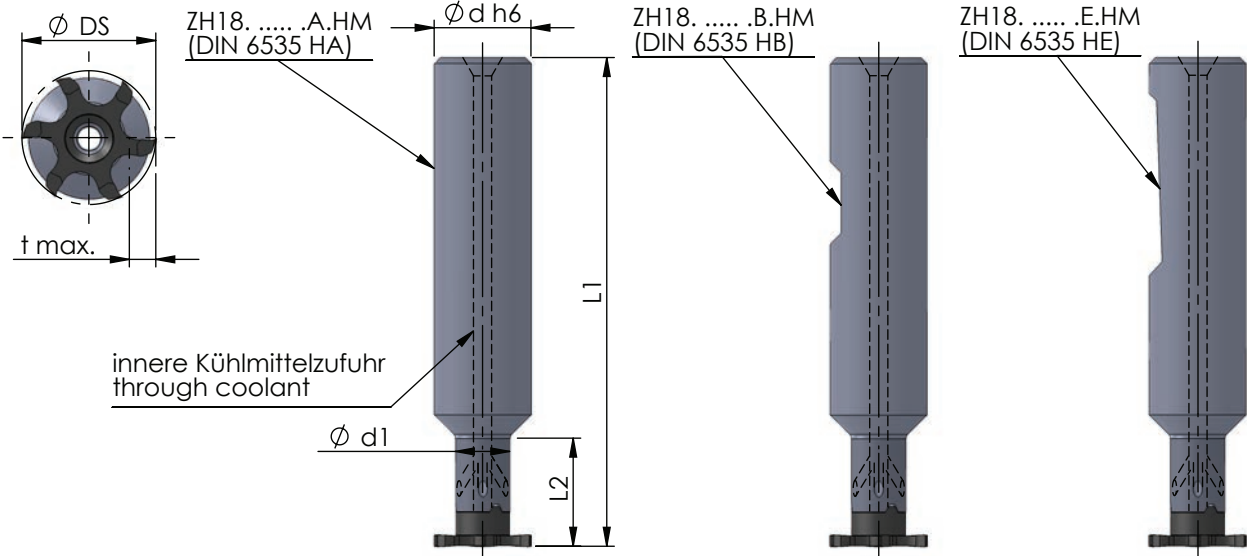

Abmessungen und Beschreibungen gelten für alle Varianten

dimensions and descriptions are valid for all versions

Abmessungen in mm

dimensions in mm

Bestellnummer part number	Ø d h6	Ø d (inch)	Ø d1	L1	L2	Typ: t max./ Schneidkreis-Ø DS	Spannschraube screw	Schraubenschlüssel wrench	Anzugs- drehmoment torque	für Schneideinsatz for insert
neu ZH18.1209.32.A.HM /...B.HM /...E.HM	12		9	100	32	Z18: 3.5 / 17.7 Z618: 4 / 17.7 Z620: 5 / 19.7	M4-MM	T 15F	4.5 Nm	Z18... Z618... Z620...
ZH18.U1209.32.A.HM /...B.HM	12.7	1/2"	9	100	32					
neu ZH18.1209.45.A.HM /...B.HM /...E.HM	12		9	100	45					
ZH18.U1209.45.A.HM /...B.HM	12.7	1/2"	9	100	45					
neu ZH18.1209.64.A.HM /...B.HM /...E.HM	12		9	120	64					
ZH18.U1209.64.A.HM /...B.HM	12.7	1/2"	9	120	64					
neu ZH18.U1509.45.A.HM /...B.HM	15.875	5/8"	9	110	45					
ZH18.1609.25.A.HM /...B.HM /...E.HM	16		9	93	25					
ZH18.1609.32.A.HM /...B.HM /...E.HM	16		9	100	32					
ZH18.1609.45.A.HM /...B.HM /...E.HM	16		9	110	45					
ZH18.1609.64.A.HM /...B.HM /...E.HM	16		9	130	64					
ZH18.1613.64.A.HM /...B.HM /...E.HM	16		13	110	64					
ZH18.1613.66.A.HM /...B.HM /...E.HM	16		13	130	66	t max. reduced				

Hinweis:  
Hartmetall-Frälerschäfte mit beschädigter  
Schneidplattenaufnahme können durch unseren  
Reparaturservice instand gesetzt werden.

Bestellbeispiel:  
ZH18.1613.66.A.HM

note:  
carbide-toolholder with damaged seating can be  
repaired by Dümmel.

order example:  
ZH18.1613.66.A.HM



# MINIMILL

Nut- und Formzirkularfräsen

groove milling by circular interpolation

# Typ ZH22

Fräferschaft Stahl

milling shank steel

D min. 22 mm

D min. 22 mm

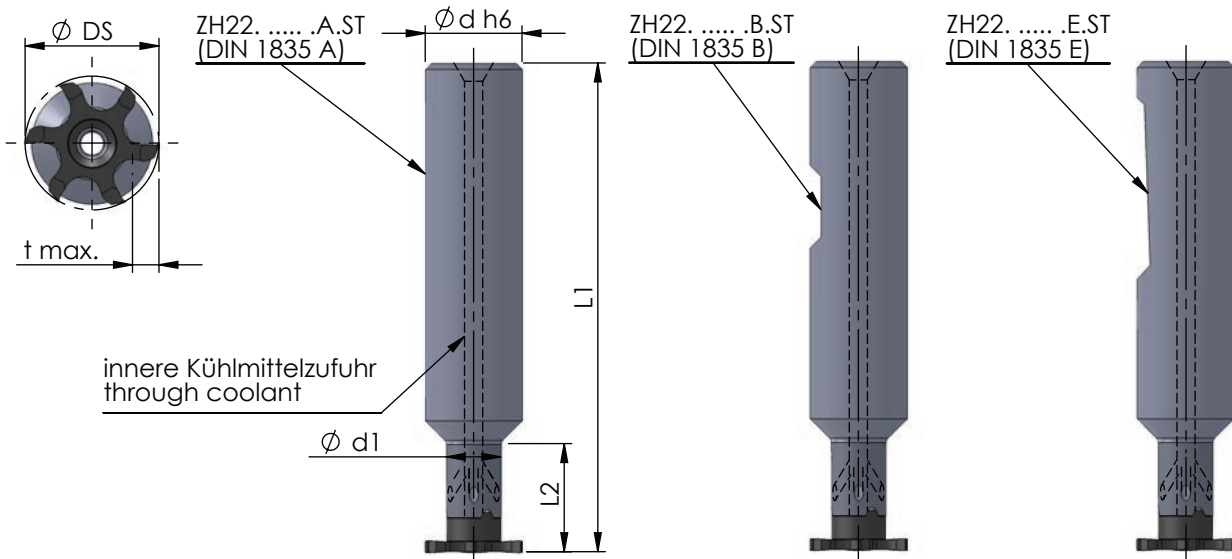

Abmessungen und Beschreibungen gelten für alle Varianten

dimensions and descriptions are valid for all versions

Abmessungen in mm

dimensions in mm

Bestellnummer part number	$\varnothing d_{h6}$	d1	L1	L2	Typ: t max./ Schneidkreis- $\varnothing DS$	Spannschraube screw	Schraubenschlüssel wrench	Anzugs- drehmoment torque	für Schneideinsatz for insert
ZH22.1011.10.A.ST	10	11.3	60	10.7	Z22: 4.5 / 21.7	M5-MM	T 20F	7.0 Nm	Z22...
ZH22.1311.25.A.ST	13	11.3	70	25.7	Z622: 4.5 / 21.7				Z622...
ZH22.1612.24.A.ST /...B.ST /...E.ST	16	12	80	24	Z33: 10 / 32.7 Z33: 12 / 32.7 Z637: 12 / 36.7 Z640: 13.5 / 39.7				Z33... Z637... Z640...

Bestellbeispiel:  
ZH22.1612.24.A.ST



**MINIMILL**

Nut- und Formzirkularfräsen

groove milling by circular interpolation

**Typ ZH22**

Frälerschaft Hartmetall

D min. 22 mm

milling shank carbide

D min. 22 mm

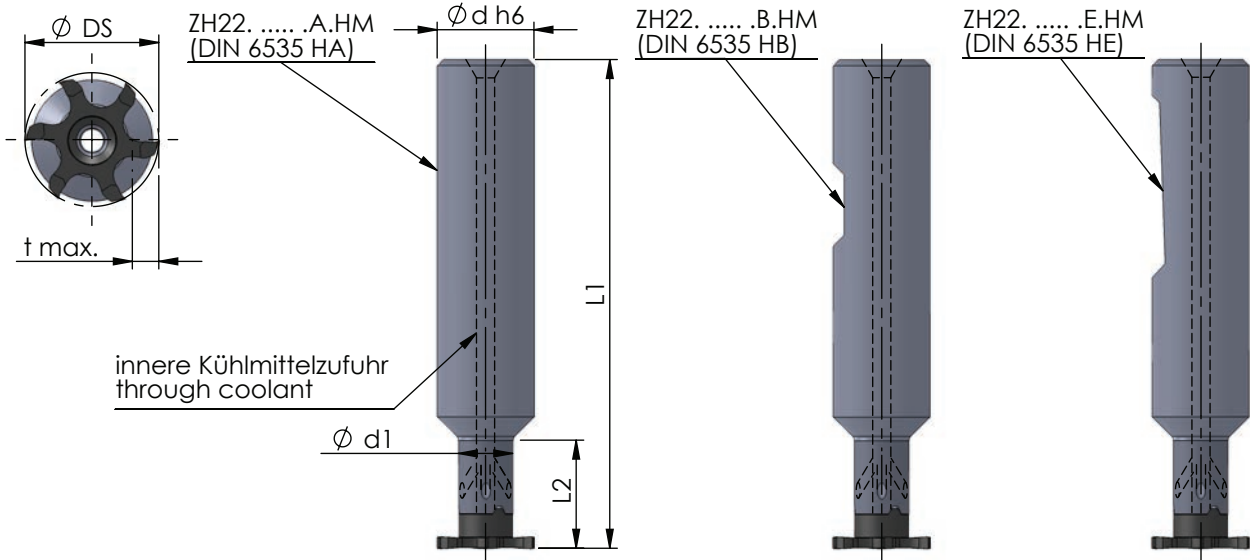

Abmessungen und Beschreibungen gelten für alle Varianten

dimensions and descriptions are valid for all versions

Abmessungen in mm

dimensions in mm

Bestellnummer part number	Ø d h6	Ø d (inch)	Ø d1	L1	L2	Typ: t max./ Schneidkreis-Ø DS	Spannschraube screw	Schraubenschlüssel wrench	Anzugs- drehmoment torque	für Schneideinsatz for insert
ZH22.1212.42.A.HM /...B.HM /...E.HM	12	-	100	42		Z22: 4.5 / 21.7 Z622: 4.5 / 21.7 Z33: 10 / 32.7 Z33: 12 / 32.7 Z637: 12 / 36.7 Z640: 13.5 / 39.7	M5-MM	T 20F	7.0 Nm	Z22... Z622... Z33... Z637... Z640...
neu ZH22.U1212.42.A.HM /...B.HM	12.7	1/2"	-	100	42					
ZH22.1212.60.A.HM /...B.HM /...E.HM	12	-	130	60						
neu ZH22.U1212.60.A.HM /...B.HM	12.7	1/2"	-	130	60					
neu ZH22.U1511.30.A.HM /...B.HM	15.875	5/8"	11.5	90	30					
neu ZH22.U1512.42.A.HM /...B.HM	15.875	5/8"	12	100	42					
neu ZH22.U1512.60.A.HM /...B.HM	15.875	5/8"	12	130	60					
neu ZH22.U1512.85.A.HM /...B.HM	15.875	5/8"	12	160	85					
ZH22.1611.30.A.HM /...B.HM /...E.HM	16	11.5	90	30						
ZH22.1612.42.A.HM /...B.HM /...E.HM	16	12	100	42						
ZH22.1612.60.A.HM /...B.HM /...E.HM	16	12	130	60						
ZH22.1612.85.A.HM /...B.HM /...E.HM	16	12	160	85						
ZH22.2016.45.A.HM /...B.HM /...E.HM	20	16	110	45	t max. reduziert					
ZH22.2016.65.A.HM /...B.HM /...E.HM	20	16	130	65	t max. reduced					

Hinweis:  
Hartmetall-Frälerschäfte mit beschädigter  
Schneidplattenaufnahme können durch unseren  
Reparaturservice instand gesetzt werden.

note:  
carbide-toolholder with damaged seating can be  
repaired by Dümmel.

Bestellbeispiel:  
ZH22.2016.65.A.HM

order example:  
ZH22.2016.65.A.HM



# MINIMILL

Nut- und Formzirkularfräsen

groove milling by circular interpolation

# Typ ZH28

Fräferschaft Stahl

milling shank steel

D min. 25 mm

D min. 25 mm

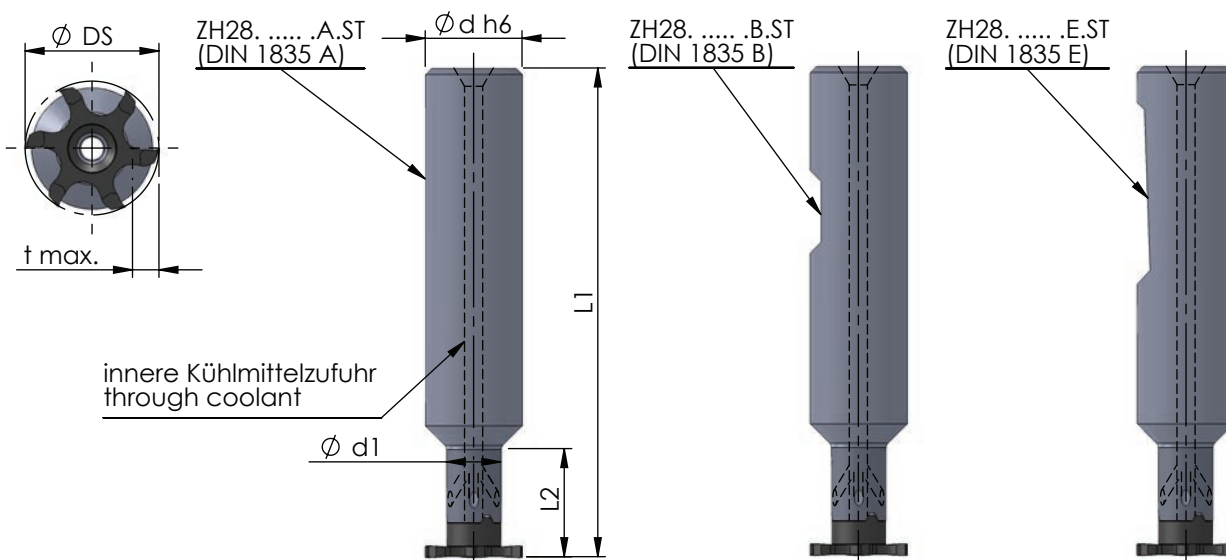

Abmessungen und Beschreibungen gelten für alle Varianten

dimensions and descriptions are valid for all versions

Abmessungen in mm

dimensions in mm

Bestellnummer part number					Typ: t max./ Schneidkreis- $\varnothing DS$	Spannschraube screw	Schraubenschlüssel wrench	Anzugs- drehmoment torque	für Schneideinsatz for insert
	$\varnothing d_{h6}$	$d_1$	$L_1$	$L_2$					
ZH28.1314.10.A.ST	13	14	70	10.7	Z25: 5 / 24.8 Z28: 6.5 / 27.7 Z628: 6.5 / 27.7 Z32: 8.5 / 31.7 Z635: 10 / 34.7	M5-MM	T 20F	7.0 Nm	Z25... Z28... Z628... Z32... Z635...
ZH28.2014.35.A.ST / ...B.ST	20	14	100	35.7					

Bestellbeispiel:  
ZH28.2014.35.A.ST



**MINIMILL**

Nut- und Formzirkularfräsen

groove milling by circular interpolation

**Typ ZH28**

Frälerschaft Hartmetall

D min. 25 mm

milling shank carbide

D min. 25 mm

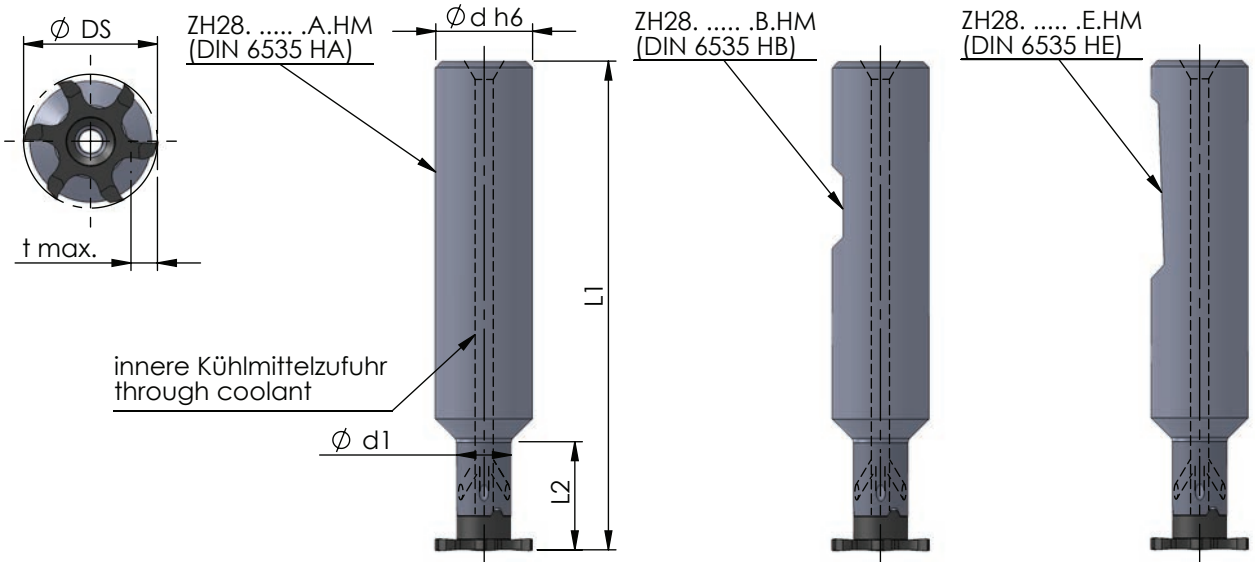

Abmessungen und Beschreibungen gelten für alle Varianten

dimensions and descriptions are valid for all versions

Abmessungen in mm

dimensions in mm

Bestellnummer part number	Ø d h6	Ø d (inch)	Ø d1	L1	L2	Typ: t max./ Schneidkreis-Ø DS	Spannschraube screw	Schraubenschlüssel wrench	Anzugs- drehmoment torque	für Schneideinsatz for insert
neu ZH28.U1514.42.A.HM /...B.HM	15.875	5/8"	14.3	100	42	Z25: 5 / 24.8 Z28: 6.5 / 27.7 Z628: 6.5 / 27.7 Z32: 8.5 / 31.7 Z635: 10 / 34.7	M5-MM	T 20F	7.0 Nm	Z25... Z28... Z628... Z32... Z635...
neu ZH28.U1514.60.A.HM /...B.HM	15.875	5/8"	14.3	130	60					
neu ZH28.U1514.85.A.HM /...B.HM	15.875	5/8"	14.3	160	85					
ZH28.1614.42.A.HM /...B.HM /...E.HM	16		14.3	100	42					
ZH28.1614.60.A.HM /...B.HM /...E.HM	16		14.3	130	60					
ZH28.1614.85.A.HM /...B.HM /...E.HM	16		14.3	160	85					
ZH28.2013.35.A.HM /...B.HM /...E.HM	20		13.5	104	35					
ZH28.2014.85.A.HM /...B.HM /...E.HM	20		14.3	160	85					

Hinweis:  
Hartmetall-Frälerschäfte mit beschädigter  
Schneidplattenaufnahme können durch unseren  
Reparaturservice instand gesetzt werden.

Bestellbeispiel:  
ZH28.2014.85.A.HM

note:  
carbide-toolholder with damaged seating can be  
repaired by Dümmel.

order example:  
ZH28.2014.85.A.HM



# MINIMILL

Nut- und Formzirkularfräsen

groove milling by circular interpolation

# Typ ZH28

Fräferschaft Schwermetall

milling shank heavy metal

D min. 28 mm

D min. 28 mm

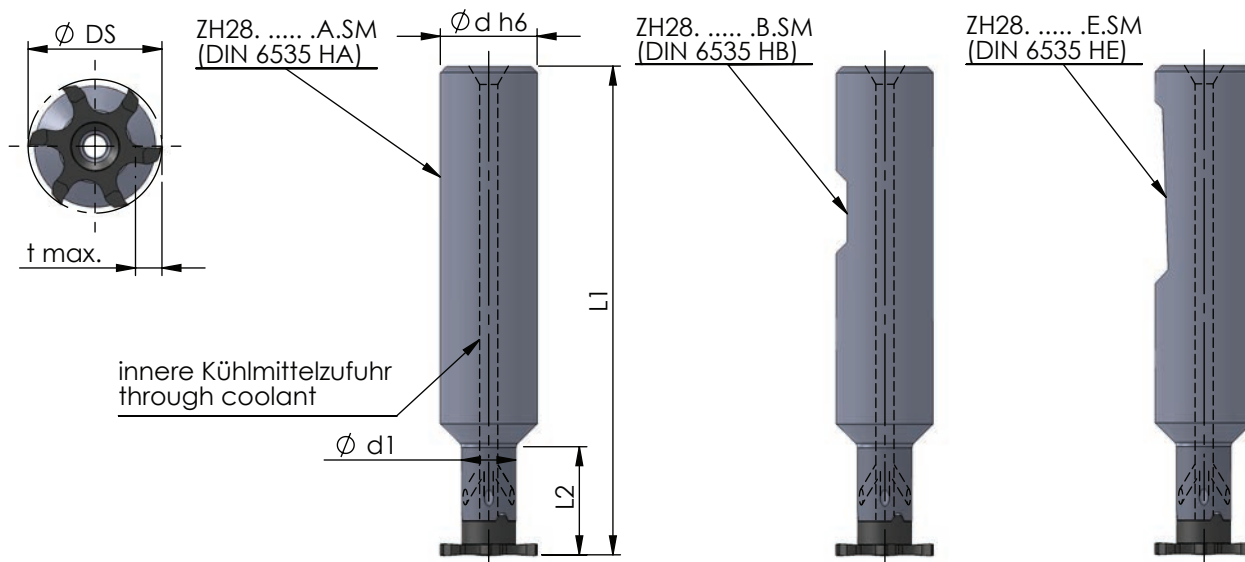

Abmessungen und Beschreibungen gelten für alle Varianten

dimensions and descriptions are valid for all versions

Abmessungen in mm

dimensions in mm

Bestellnummer part number	$\varnothing d h6$	d1 *	L1	L2	Typ: t max./ * Schneidkreis- $\varnothing DS$	Spannschraube screw	Schraubenschlüssel wrench	Anzugs- drehmoment torque	für Schneideinsatz for insert
ZH28.2020.35.A.SM /...B.SM /...E.SM	20	20	145	-					
ZH28.2015.30.A.SM /...B.SM /...E.SM	20	15	160	30					
ZH28.2020.90.A.SM /...B.SM /...E.SM	20	20	200	-	Z28... Z628... Z32... Z635...				

\* Achtung:  
Durch die extrastabile Ausführung ist das t max. reduziert.

\* attention:  
The measure t max. is reduced by the extra-stable implementation.

Bestellbeispiel:  
ZH28.2020.90.A.SM

order-example:  
ZH28.2020.90.A.SM

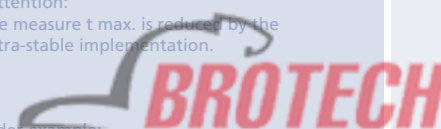

**MINIMILL**

Nut- und Formzirkularfräsen

groove milling by circular interpolation

**Typ ZH33**

Frälerschaft Hartmetall

D min. 28 mm

milling shank carbide

D min. 28 mm

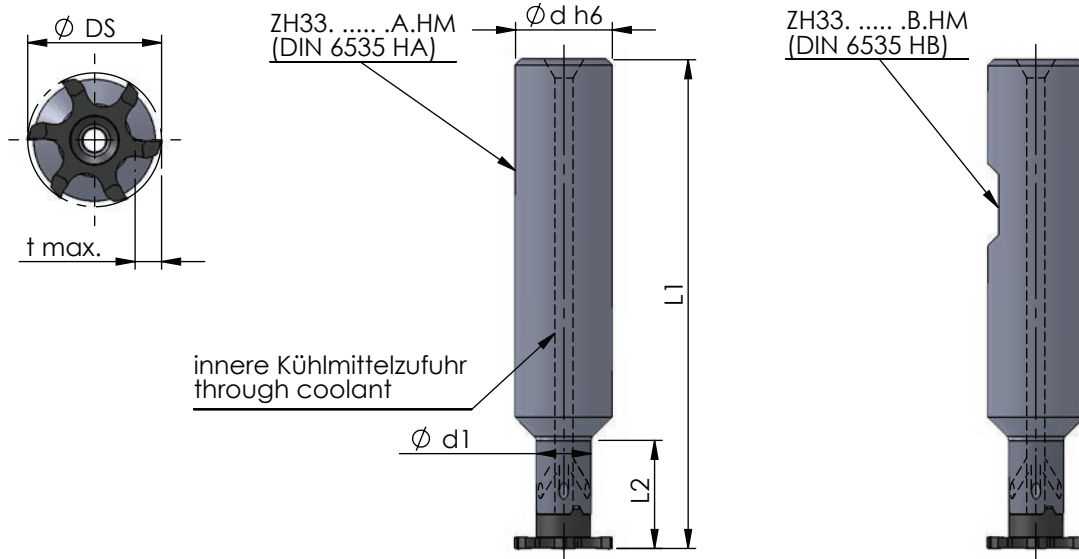

Abmessungen und Beschreibungen gelten für alle Varianten

dimensions and descriptions are valid for all versions

Abmessungen in mm

dimensions in mm

Bestellnummer part number	$\varnothing d h6$	$d1$	L1	L2	Typ: t max./ Schneidkreis- $\varnothing DS$	Spannschraube screw	Schraubenschlüssel wrench	Anzugs- drehmoment torque	für Schneideinsatz for insert
ZH33.1209.32.A.HM / -	12	9	100	32	Z28: 9.3 / 28	M5-MM	T 20F	7.0 Nm	Z28. .... Z628.150.02.9 Z33.170.42.12
ZH33.1609.33.A.HM / ...B.HM	16	9	100	33	Z628. ....9 : 9.3 / 27.7 Z33. ....12 : 12 / 33.6				

Hinweis:  
Hartmetall-Frälerschäfte mit beschädigter Schneidplattenaufnahme können durch unseren Reparaturservice instand gesetzt werden.

note:  
carbide-toolholder with damaged seating can be repaired by Dümmel.

Bestellbeispiel:  
ZH33.1609.33.A.HM

order-example:  
ZH33.1609.33.A.,HM



# MINIMILL

Nut- und Formzirkularfräsen

groove milling by circular interpolation

# Impressionen

impressions

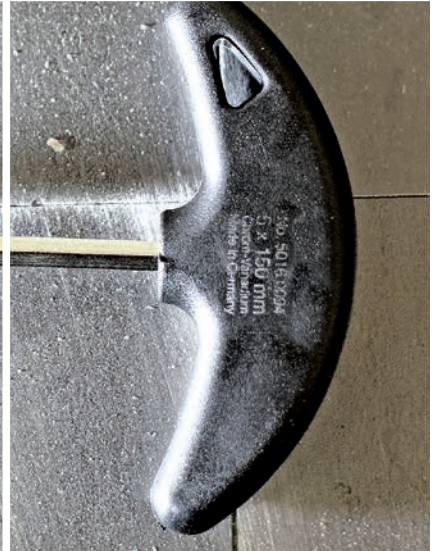
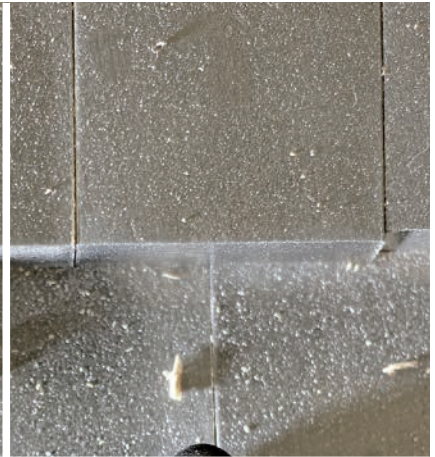



**MINIMILL**

Nut- und Formzirkularfräsen

groove milling by circular interpolation

**Typ Z10**

Sicherungsringe DIN 471 / 472  
und Nutfräsen allgemein

D min. 10 mm  
t max. = 1.5

for circlip grooves DIN 471 / 472  
and groove milling general use

D min. 10 mm  
t max. = 1.5

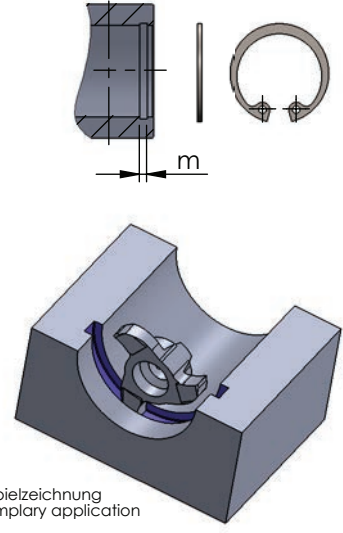
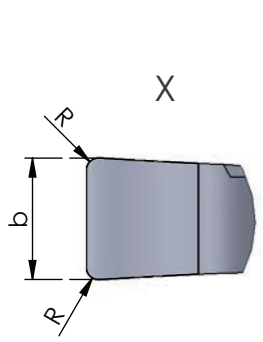
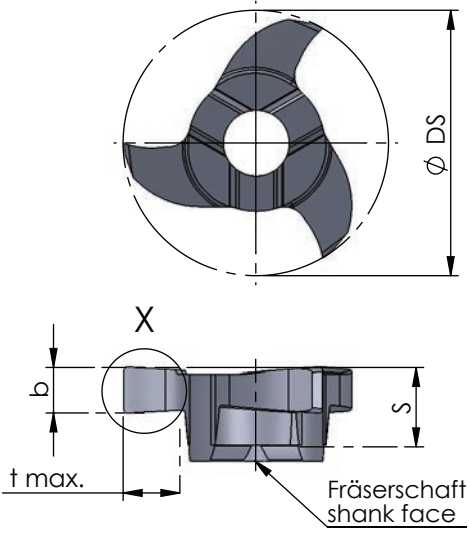

Beispielzeichnung  
exemplary application

Abmessungen in mm

dimensions in mm

Bestellnummer part number	D min.	Nut-Maß m groove dim. m	DIN 471 / DIN 472	S	R	Ø DS	b +0.02 (* b -0.02)	t max.	Zähnezahl number of teeth	K10F AL41F P18C	für Fräseschaft for milling shank
Z10.0070.00	10	0.7	☉	3.4	-	9.7	0.74*	1.5	3	●	ZH10...
Z10.0080.00	10	0.8	☉	3.4	-	9.7	0.84*	1.5	3	●	
Z10.0090.00	10	0.9	☉	3.4	-	9.7	0.94*	1.5	3	●	
Z10.0100.00	10	-	-	3.4	0.1	9.7	1.00	1.5	3	●	
Z10.0110.00	10	1.1	☉	3.5	-	9.7	1.21*	1.5	3	●	
Z10.0130.00	10	1.3	☉	3.5	0.1	9.7	1.41*	1.5	3	●	
Z10.0150.00	10	-	-	3.5	0.2	9.7	1.50	1.5	3	●	
Z10.0160.00	10	1.6	☉	3.5	0.1	9.7	1.71*	1.5	3	●	
Z10.0200.00	10	-	-	3.5	0.2	9.7	2.00	1.5	3	●	
Z10.0250.00	10	-	-	3.5	0.2	9.7	2.50	1.5	3	●	

Weitere HM Sorten können Sie in der Sortenübersicht im Kapitel "Technische Hinweise" und der Preisliste finden.

Bestellbeispiel:  
für Sorte AL41F:  
Z10.0160.00/AL41F

More carbide grades you can find in the grades summary in the chapter "technical instructions" and in the price list.

order example:  
grade AL41F:  
Z10.0160.00/AL41F



# MINIMILL

Nut- und Formzirkularfräsen

groove milling by circular interpolation

# Typ Z12

Sicherungsringe DIN 471 / 472 und Nutfräsen allgemein

D min. 12 mm  
t max. = 2.5

for circlip grooves DIN 471 / 472 and groove milling general use

D min. 12 mm  
t max. = 2.5

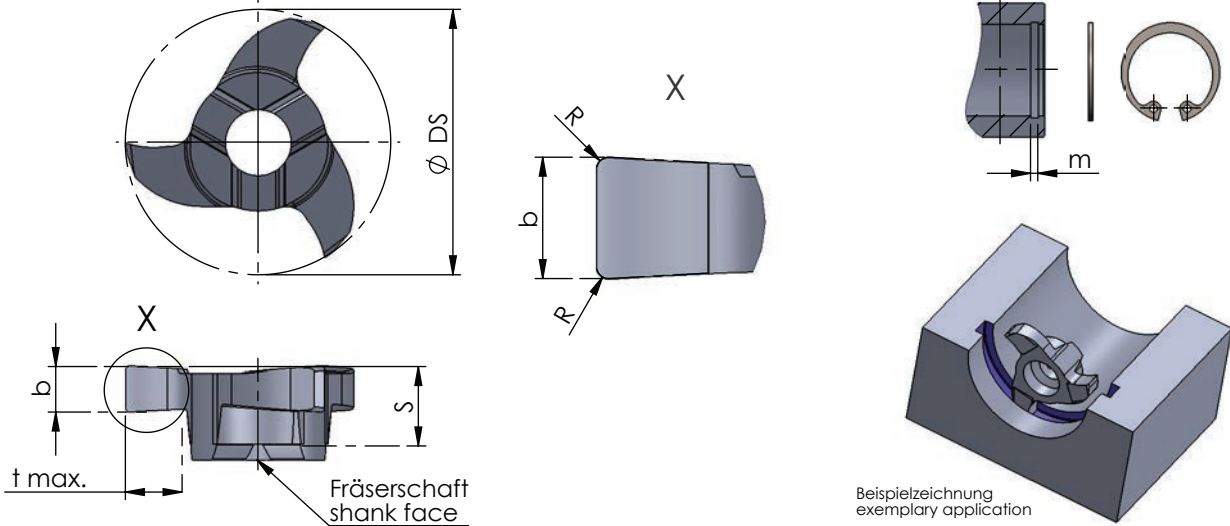

Abmessungen in mm

dimensions in mm

neu

Bestellnummer part number	D min.	Nut-Maß m groove dim. m DIN 471 / DIN 472	S	R	Ø DS	b +0.02 (* b -0.02)	b (inch)	t max.	Zähnezahl number of teeth	K10F	AL41F	P18C	für Fräseschaft for milling shank
Z12.0110.00	12	1.1	3.5	-	11.7	1.21*		2.5	3	●			ZH10...
Z12.0117.00	12	-	3.5	-	11.7	1.17	0.046"	2.5	3	●			
Z12.0130.00	12	1.3	3.5	0.1	11.7	1.41*		2.5	3	●			
Z12.0142.01	12	-	3.5	0.1	11.7	1.42	0.056"	2.5	3	●			
Z12.0150.02	12	-	3.5	0.2	11.7	1.50		2.5	3	●			
Z12.0157.02	12	-	3.5	0.2	11.7	1.57	0.062"	2.5	3	●			
Z12.0160.00	12	1.6	3.5	0.1	11.7	1.71*		2.5	3	●			
Z12.0198.02	12	-	3.5	0.2	11.7	1.98	0.078"	2.5	3	●			
Z12.0200.00	12	-	3.5	0.2	11.7	2.00		2.5	3	●			
Z12.0238.02	12	-	3.5	0.2	11.7	2.39	0.094"	2.5	3	●			
Z12.0250.00	12	-	3.5	0.2	11.7	2.50		2.5	3	●			
Z12.0300.00	12	-	3.5	0.2	11.7	3.00		2.5	3	●			

Weitere HM Sorten können Sie in der Sortenübersicht im Kapitel "Technische Hinweise" und der Preisliste finden.

Bestellbeispiel:  
für Sorte AL41F:  
Z12.0160.00/AL41F

More carbide grades you can find in the grades summary in the chapter "technical instructions" and in the price list.

order-example:  
grade AL41F:  
Z12.0160.00/AL41F



**MINIMILL**

Nut- und Formzirkularfräsen

groove milling by circular interpolation

**Typ Z612 / Z612.X**

Nutfräsen allgemein

for groove milling general use

D min. 12 mm  
t max. = 2

D min. 12 mm  
t max. = 2

**Z612 geradverzahnt / spur-toothed**

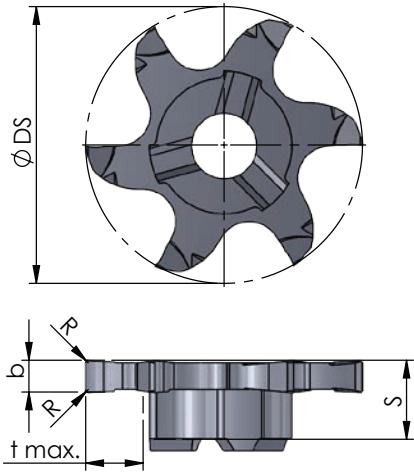

**Z612.X kreuzverzahnt / staggered-toothed**

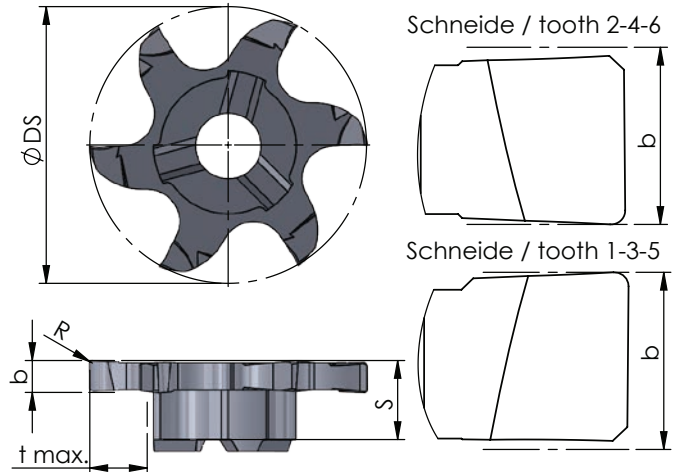

Abmessungen in mm

dimensions in mm

Bestellnummer part number	D min.	S	R	Ø DS	b +0.02	t max.	Zähnezahl number of teeth	Material			für Fräseschaft for milling shank
								K10F	AL41F	P18C	
Z612.0150.02	12	3.5	0.2	11.7	1.5	2.0	6	●			
Z612.X150.02	12	3.5	0.2	11.7	1.5	2.0	6		●		
Z612.0200.02	12	3.5	0.2	11.7	2.0	2.0	6		●		
Z612.X200.02	12	3.5	0.2	11.7	2.0	2.0	6		●		ZH10...

Weitere HM Sorten können Sie in der Sortenübersicht im Kapitel "Technische Hinweise" und der Preisliste finden.

Bestellbeispiel:  
für Sorte AL41F:  
Z612.0150.02/AL41F

More carbide grades you can find in the grades summary in the chapter "technical instructions" and in the price list.

order example:  
grade AL41F:  
Z612.0150.02/AL41F



# MINIMILL

Nut- und Formzirkularfräsen

groove milling by circular interpolation

# Typ Z14

Nutfräsen allgemein

for groove milling general use

D min. 14 mm  
t max. = 2.5

D min. 14 mm  
t max. = 2.5

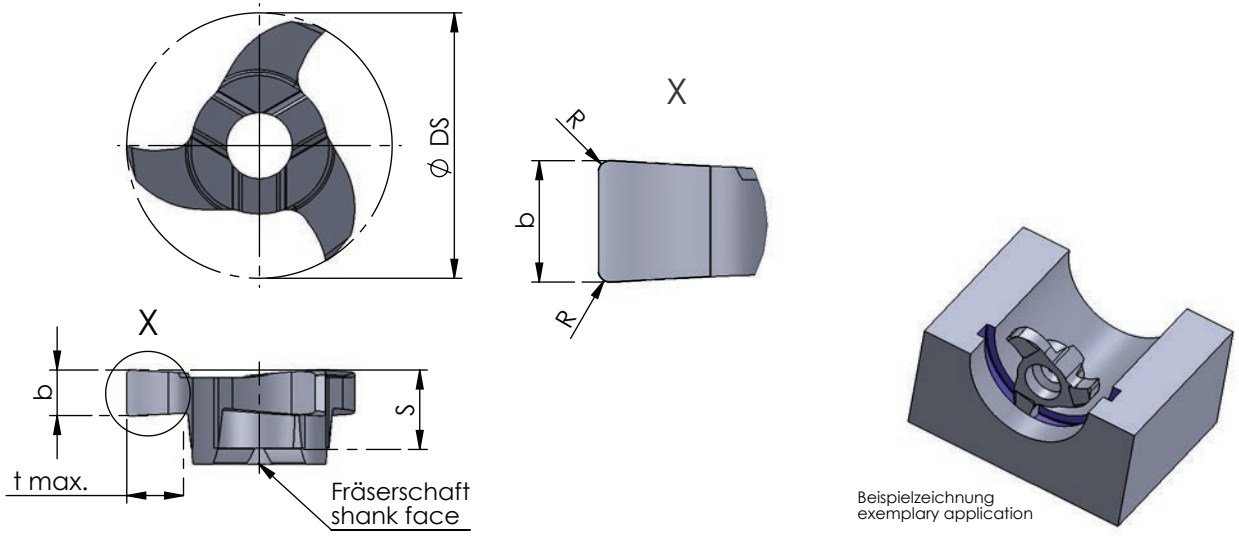

Abmessungen in mm

dimensions in mm

Bestellnummer part number	D min.	S	R	Ø DS	b +0.02	t max.	Zähnezahl number of teeth				für Fräseschaft for milling shank
								K10F	AL41F	P18C	
Z14.0100.00	14	4.5	0.1	13.7	1.0	2.5	3	●			ZH14...
Z14.0150.00	14	4.5	0.2	13.7	1.5	2.5	3		●		
Z14.0200.02	14	4.5	0.2	13.7	2.0	2.5	3		●		
Z14.0250.02	14	4.5	0.2	13.7	2.5	2.5	3		●		

Weitere HM Sorten können Sie in der Sortenübersicht im Kapitel "Technische Hinweise" und der Preisliste finden.

Bestellbeispiel:  
für Sorte AL41F:  
Z14.0150.00/AL41F

More carbide grades you can find in the grades summary in the chapter "technical instructions" and in the price list.

order example:  
grade AL41F:  
Z14.0150.00/AL41F

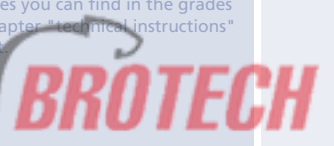

## MINIMILL

Nut- und Formzirkularfräsen

groove milling by circular interpolation

## Typ Z16

Nutfräsen allgemein

for groove milling general use

D min. 16 mm  
t max. = 3.5

D min. 16 mm  
t max. = 3.5

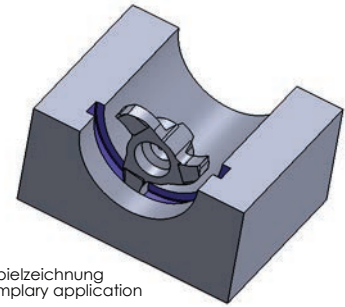
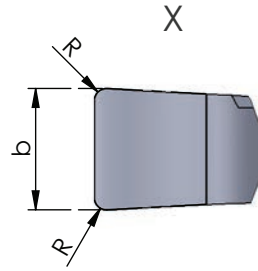
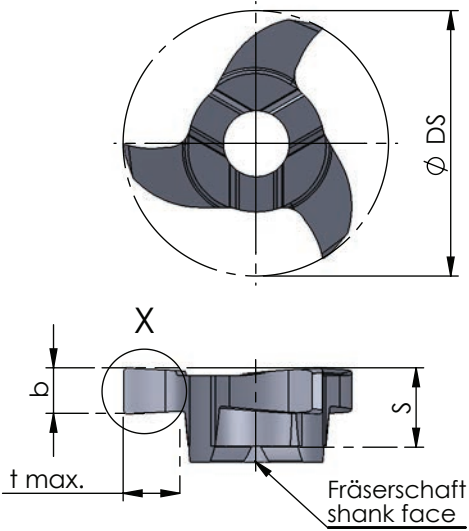

Beispielzeichnung  
exemplary application

Abmessungen in mm

dimensions in mm

Bestellnummer part number	D min.	S	R	$\varnothing DS$	b +0.02	b (inch)	t max.	Zähnezahl number of teeth				für Fräterschaft for milling shank
									K10F	AL41F	P18C	
Z16.0117.00	16	4.5	-	15.7	1.17	0.046"	3.5	3	●			
Z16.0150.00	16	4.5	0.2	15.7	1.5		3.5	3	●			
Z16.0157.02	16	4.5	0.2	15.7	1.57	0.062"	3.5	3	●			
Z16.0200.02	16	4.5	0.2	15.7	2.0		3.5	3	●			
Z16.0238.02	16	4.5	0.2	15.7	2.39	0.094"	3.5	3	●			ZH14...
Z16.0250.02	16	4.5	0.2	15.7	2.5		3.5	3	●			
Z16.0318.02	16	4.5	0.2	15.7	3.18	0.125"	3.5	3	●			

Weitere HM Sorten können Sie in der Sortenübersicht im Kapitel "Technische Hinweise" und der Preisliste finden.

Bestellbeispiel:  
für Sorte AL41F:  
Z16.0150.00/AL41F

More carbide grades you can find in the grades summary in the chapter "technical instructions" and in the price list.

order-example:  
grade AL41F:  
Z16.0150.00/AL41F

**BROTECH**

# MINIMILL

Nut- und Formzirkularfräsen

groove milling by circular interpolation

# Typ Z616 / Z616.X

Nutfräsen allgemein

for groove milling general use

D min. 16 mm  
t max. = 3.5

D min. 16 mm  
t max. = 3.5

Z616 geradverzahnt / spur-toothed

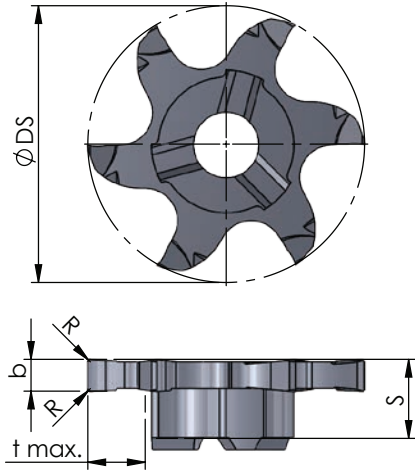

Z616.X kreuzverzahnt / staggered-toothed

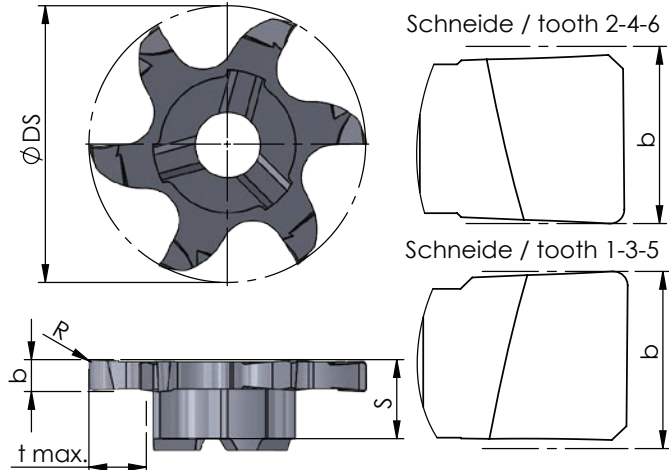

Abmessungen in mm

dimensions in mm

Bestellnummer part number	D min.	S	R	Ø DS	b +0.02	t max.	Zähnezahl number of teeth	Material			für Fräterschaft for milling shank
								K10F	AL41F	P18C	
Z616.X150.02	16	4.5	0.2	15.7	1.5	3.5	6	●			ZH14...
Z616.0200.02	16	4.5	0.2	15.7	2.0	3.5	6		●		
Z616.X200.02	16	4.5	0.2	15.7	2.0	3.5	6		●		
Z616.0250.02	16	4.5	0.2	15.7	2.5	3.5	6		●		
Z616.X250.02	16	4.5	0.2	15.7	2.5	3.5	6		●		

Weitere HM Sorten können Sie in der Sortenübersicht im Kapitel "Technische Hinweise" und der Preisliste finden.

Bestellbeispiel:  
für Sorte AL41F:  
Z616.X150.02/AL41F

More carbide grades you can find in the grades summary in the chapter "technical instructions" and in the price list.

order example:  
grade AL41F:  
Z616.X150.02/AL41F



**MINIMILL**

Nut- und Formzirkularfräsen

groove milling by circular interpolation

**Typ Z18**

Sicherungsringe DIN 471 / 472  
und Nutfräsen allgemein

D min. 18 mm  
t max. ≤ 3.5

for circlip grooves DIN 471 / 472  
and groove milling general use

D min. 18 mm  
t max. ≤ 3.5

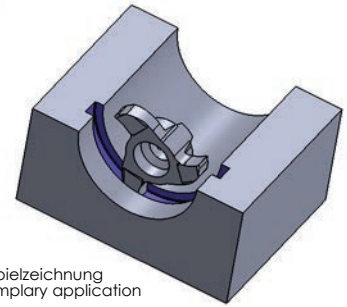
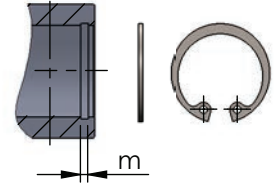
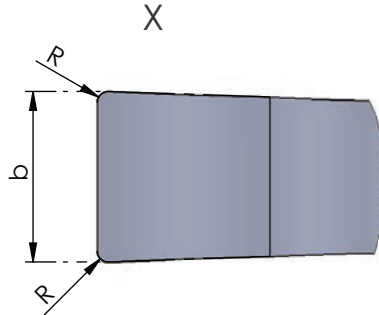
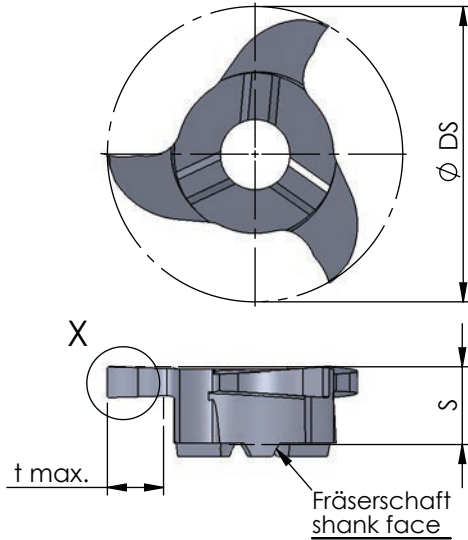

Abmessungen in mm

dimensions in mm

Bestellnummer part number	D min.	Nut-Maß m groove dim. m DIN 471 / DIN 472	S	R	Ø DS	b +0.02 (* b -0.02)	b (inch)	t max.	Zähnezahl number of teeth	K10F	AL41F	P18C	für Fräseschaft for milling shank
Z18.0070.00	18	0.7	5.6	-	17.7	0.74*		1.5	3	●			ZH18...
Z18.0080.00	18	0.8	5.6	-	17.7	0.84*		1.7	3	●			
Z18.0090.00	18	0.9	5.6	-	17.7	0.94*		1.9	3	●			
Z18.0110.00	18	1.1	5.8	-	17.7	1.21*		3.5	3	●			
Z18.0117.00	18	-	5.8	-	17.7	1.17	0.046"	3.5	3	●			
Z18.0130.00	18	1.3	5.8	0.1	17.7	1.41*		3.5	3	●			
Z18.0142.01	18	-	5.8	0.1	17.7	1.42	0.056"	3.5	3	●			
Z18.0150.00	18	-	5.8	0.2	17.7	1.50		3.5	3	●			
Z18.0157.02	18	-	5.8	0.2	17.7	1.57	0.062"	3.5	3	●			
Z18.0160.00	18	1.6	5.8	0.1	17.7	1.71*		3.5	3	●			
↳ ...													

Weitere HM Sorten können Sie in der Sortenübersicht im Kapitel "Technische Hinweise" und der Preisliste finden.

Bestellbeispiel:  
für Sorte AL41F:  
Z18.0110.00/AL41F

More carbide grades you can find in the grades summary in the chapter "technical instructions" and in the price list.

order-example:  
grade AL41F:  
Z18.0110.00/AL41F



# MINIMILL

Nut- und Formzirkularfräsen

groove milling by circular interpolation

# Typ Z18

Sicherungsringe DIN 471 / 472 und Nutfräsen allgemein

D min. 18 mm  
t max. ≤ 3.5

for circlip grooves DIN 471 / 472 and groove milling general use

D min. 18 mm  
t max. ≤ 3.5

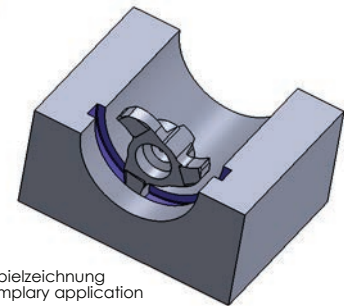
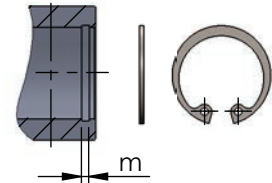
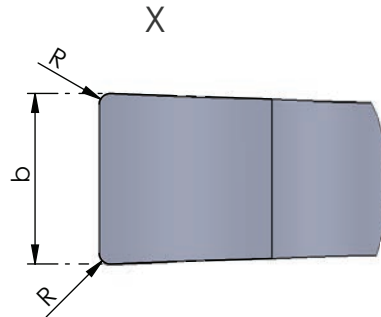
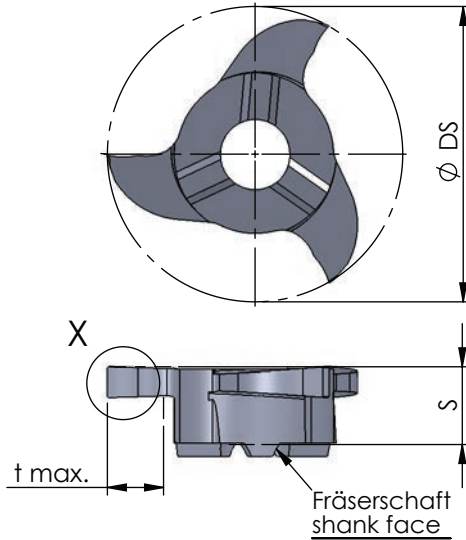

Beispielzeichnung  
exemplary application

Abmessungen in mm

dimensions in mm

Bestellnummer part number	D min.	Nut-Maß m groove dim. m DIN 471 / DIN 472	S	R	Ø DS	b +0.02 (* b -0.02)	b (inch)	t max.	Zähnezahl number of teeth				für Fräterschaft for milling shank
										K10F	AL41F	P18C	
...													
Z18.0198.02	18	-	5.8	0.2	17.7	1.98	0.078"	3.5	3	●			ZH18...
Z18.0200.02	18	-	5.8	0.2	17.7	2.00		3.5	3	●			
Z18.0238.02	18	-	5.8	0.2	17.7	2.39	0.094"	3.5	3	●			
Z18.0250.02	18	-	5.8	0.2	17.7	2.50		3.5	3	●			
Z18.0300.02	18	-	5.8	0.2	17.7	3.00		3.5	3	●			
Z18.0318.02	18	-	5.8	0.2	17.7	3.18	0.125"	3.5	3	●			
Z18.0400.02	18	-	5.8	0.2	17.7	4.00		3.5	3	●			

Weitere HM Sorten können Sie in der Sortenübersicht im Kapitel "Technische Hinweise" und der Preisliste finden.

Bestellbeispiel:  
für Sorte AL41F:  
Z18.0198.02/AL41F

More carbide grades you can find in the grades summary in the chapter "technical instructions" and in the price list.

order-example:  
grade AL41F:  
Z18.0198.02/AL41F



**MINIMILL**

Nut- und Formzirkularfräsen

groove milling by circular interpolation

**Typ Z618**

Sicherungsringe DIN 471 / 472

D min. 18 mm  
t max. = 4

for circlip grooves DIN 471 / 472

D min. 18 mm  
t max. = 4

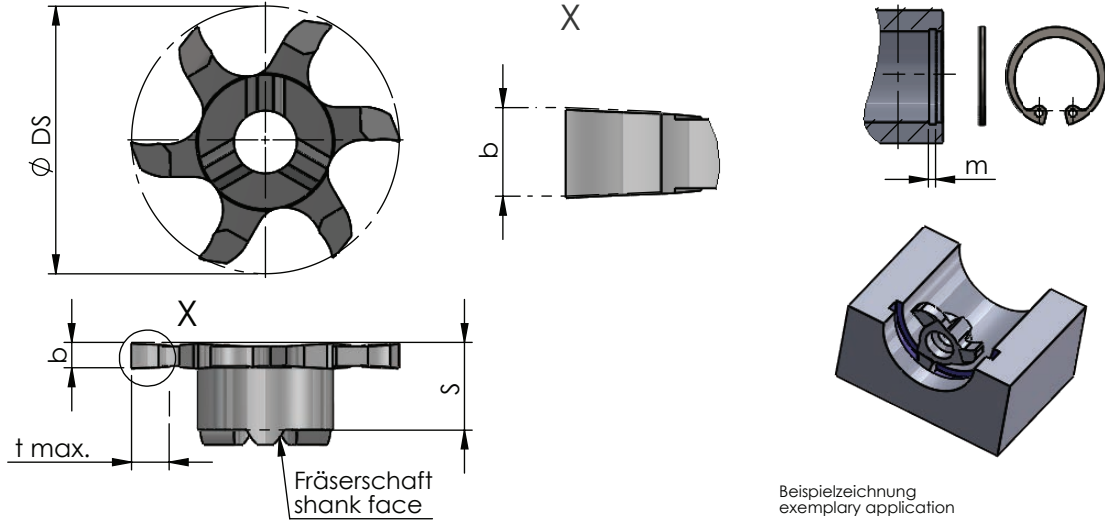

Beispielzeichnung  
exemplary application

Abmessungen in mm

dimensions in mm

Bestellnummer part number	D min.	Nut-Maß m groove dim. m DIN 471 / DIN 472	S	R	$\varnothing DS$	b -0.02	t max.	Zähnezahl number of teeth				für Frärschaft for milling shank
									K10F	AL41F	P18C	
Z618.0110.00	18	1.1	5.8	-	17.7	1.21	4	6	●			
Z618.0130.00	18	1.3	5.8	-	17.7	1.41	4	6	●			ZH18...
Z618.0160.00	18	1.6	5.8	-	17.7	1.71	4	6	●			

Weitere HM Sorten können Sie in der Sortenübersicht im Kapitel "Technische Hinweise" und der Preisliste finden.

Bestellbeispiel:  
für Sorte AL41F:  
Z618.0110.00/AL41F

More carbide grades you can find in the grades summary in the chapter "technical instructions" and in the price list.

order example:  
grade AL41F:  
Z618.0110.00/AL41F



# MINIMILL

Nut- und Formzirkularfräsen

groove milling by circular interpolation

# Typ Z618 / Z618.X / Z620 / Z620.X

Nutfräsen allgemein

D min. 18 / 20 mm  
t max. = 4 / 5

for groove milling general use

D min. 18 / 20 mm  
t max. = 4 / 5



Z618/Z620 geradverzahnt / spur-toothed

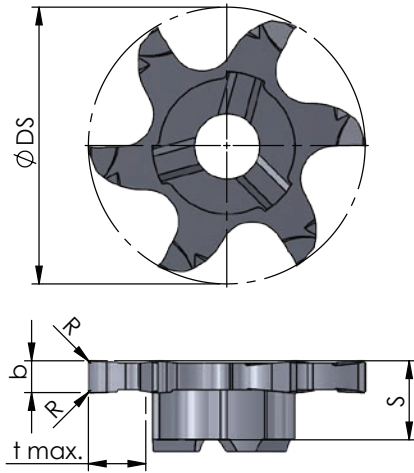

Z618.X/Z620.X kreuzverzahnt / staggered-toothed

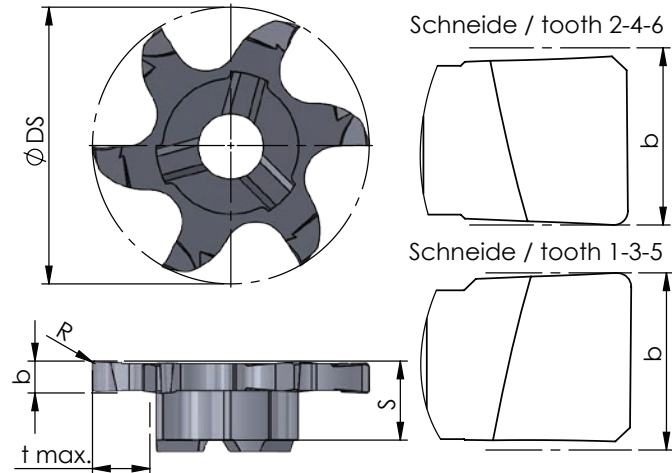

Abmessungen in mm

dimensions in mm



Bestellnummer part number	D min.	S	R	Ø DS	b +0.02	t max.	Zähnezahl number of teeth	Material			für Fräterschaft for milling shank
								K10F	AL41F	P18C	
Z618.0150.01	18	5.8	0.1	17.7	1.5	4	6	●	●	●	ZH18...
Z618.0200.02	18	5.8	0.2	17.7	2.0	4	6	●	●	●	
Z618.X200.02	18	5.8	0.2	17.7	2.0	4	6	●	●	●	
Z618.0250.02	18	5.8	0.2	17.7	2.5	4	6	●	●	●	
Z618.X250.02	18	5.8	0.2	17.7	2.5	4	6	●	●	●	
Z618.0300.02	18	5.8	0.2	17.7	3.0	4	6	●	●	●	
Z618.X300.02	18	5.8	0.2	17.7	3.0	4	6	●	●	●	
Z620.0150.01	20	5.8	0.1	19.7	1.5	5	6	●	●	●	
Z620.0200.02	20	5.8	0.2	19.7	2.0	5	6	●	●	●	
Z620.X200.02	20	5.8	0.2	19.7	2.0	5	6	●	●	●	
Z620.0250.02	20	5.8	0.2	19.7	2.5	5	6	●	●	●	
Z620.X250.02	20	5.8	0.2	19.7	2.5	5	6	●	●	●	
Z620.0300.02	20	5.8	0.2	19.7	3.0	5	6	●	●	●	
Z620.X300.02	20	5.8	0.2	19.7	3.0	5	6	●	●	●	

Weitere HM Sorten können Sie in der Sortenübersicht im Kapitel "Technische Hinweise" und der Preisliste finden.

Bestellbeispiel:  
für Sorte AL41F:  
Z618.0150.01/AL41F

More carbide grades you can find in the grades summary in the chapter "technical instructions" and in the price list.

order example:  
grade AL41F:  
Z618.0150.01/AL41F



**MINIMILL**

Nut- und Formzirkularfräsen

groove milling by circular interpolation

**Typ Z22**

Sicherungsringe DIN 471 / 472  
und Nutfräsen allgemein

D min. 22 mm  
t max. ≤ 4.5

for circlip grooves DIN 471 / 472  
and groove milling general use

D min. 22 mm  
t max. ≤ 4.5

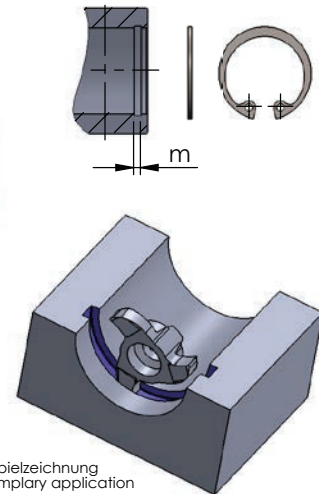
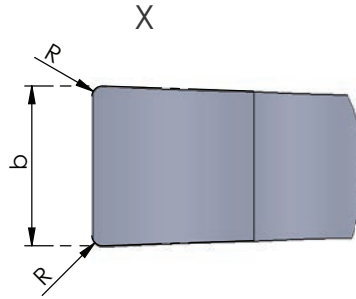
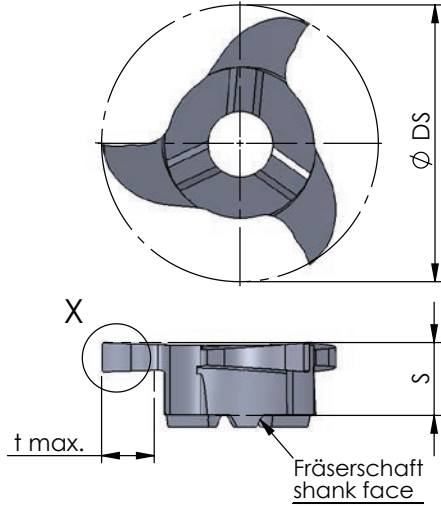

Beispielzeichnung  
exemplary application

Abmessungen in mm

dimensions in mm

Bestellnummer part number	D min.	Nut-Maß m groove dim. m DIN 471 / DIN 472	S	R	Ø DS	b +0.02 (* b -0.02)	b (inch)	t max.	Zähnezahl number of teeth	K10F	AL41F	P18C	für Fräseschaft for milling shank	
Z22.0070.00	22	0.7	5.6	-	21.7	0.74*		1.5	3	●			ZH22...	
Z22.0079.00	22	-	5.6	-	21.7	0.79	0.031"	1.5	3	●				
Z22.0080.00	22	0.8	5.6	-	21.7	0.84*		1.7	3	●				
Z22.0090.00	22	0.9	5.6	-	21.7	0.94*		1.9	3	●				
Z22.0099.00	22	-	5.6	-	21.7	0.99	0.039"	2.0	3	●				
Z22.0100.00	22	1.0	5.6	-	21.7	1.04*		2.1	3	●				
Z22.0100.01	22	-	5.6	0.10	21.7	1.00		4.5	3	●				
Z22.0110.00	22	1.1	5.7	-	21.7	1.21*		2.5	3	●				
Z22.0117.00	22	-	5.7	-	21.7	1.17	0.046"	2.5	3	●				
Z22.0130.00	22	1.3	5.7	0.10	21.7	1.41*		4.5	3	●				
Z22.0142.01	22	-	5.7	0.10	21.7	1.42	0.056"	4.5	3	●				
Z22.0150.02	22	-	5.7	0.20	21.7	1.50		4.5	3	●				
Z22.0160.00	22	1.6	5.7	0.10	21.7	1.71*		4.5	3	●				
Z22.0185.02	22	1.85	5.7	0.15	21.7	1.96*		4.5	3	●				
↳ ...														

Weitere HM Sorten können Sie in der Sortenübersicht im Kapitel "Technische Hinweise" und der Preisliste finden.

Bestellbeispiel:  
für Sorte AL41F:  
Z22.0110.00/AL41F

More carbide grades you can find in the grades summary in the chapter "technical instructions" and in the price list.

order-example:  
grade AL41F:  
Z22.0110.00/AL41F



# MINIMILL

Nut- und Formzirkularfräsen

groove milling by circular interpolation

# Typ Z22

Sicherungsringe DIN 471 / 472 und Nutfräsen allgemein

D min. 22 mm  
t max. ≤ 4.5

for circlip grooves DIN 471 / 472 and groove milling general use

D min. 22 mm  
t max. ≤ 4.5

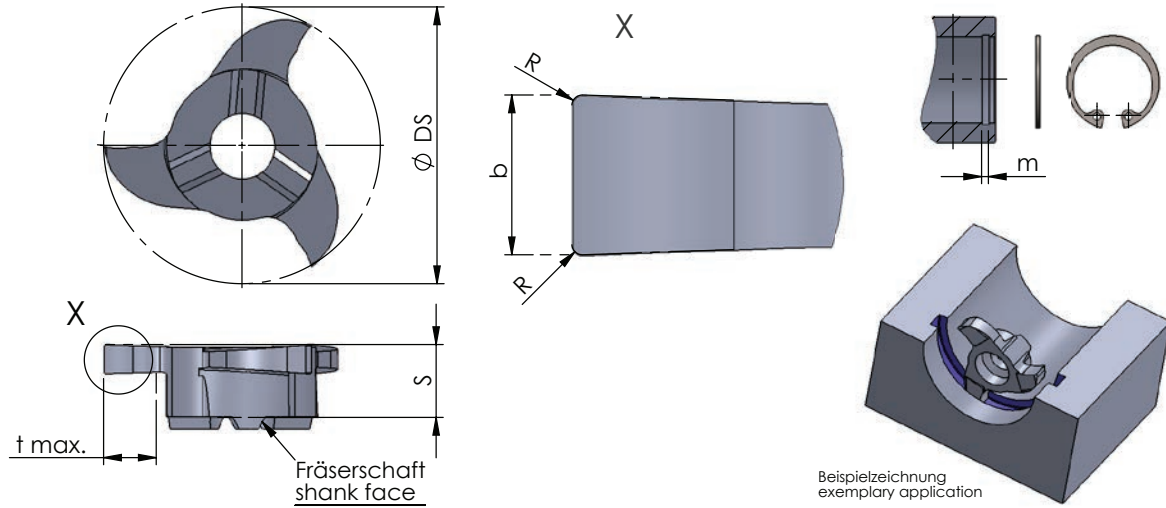

Abmessungen in mm

dimensions in mm

Bestellnummer part number	D min.	Nut-Maß m groove dim. m DIN 471 / DIN 472	S	R	$\varnothing DS$	b +0.02 (* b -0.02)	b (inch)	t max.	Zähnezahl number of teeth	Material			für Fräterschaft for milling shank
										K10F	AL41F	P18C	
...													
Z22.0198.02	22	-	5.7	0.20	21.7	1.98	0.078"	4.5	3	●			ZH22...
Z22.0200.02	22	-	5.7	0.20	21.7	2.00		4.5	3	●			
Z22.0215.02	22	2.15	5.7	0.15	21.7	2.26*		4.5	3	●			
Z22.0238.02	22	-	5.7	0.20	21.7	2.39	0.094"	4.5	3	●			
Z22.0250.02	22	-	5.7	0.20	21.7	2.50		4.5	3	●			
Z22.0265.02	22	2.65	5.7	0.15	21.7	2.76*		4.5	3	●			
Z22.0300.02	22	-	5.7	0.20	21.7	3.00		4.5	3	●			
Z22.0315.02	22	3.15	5.7	0.15	21.7	3.26*		4.5	3	●			
Z22.0350.02	22	-	5.7	0.20	21.7	3.50		4.5	3	●			
Z22.0400.02	22	-	5.7	0.20	21.7	4.00		4.5	3	●			
Z22.0415.02	22	4.15	5.7	0.15	21.7	4.26*		4.5	3	●			
Z22.0475.02	22	-	5.7	0.20	21.7	4.75	0.187"	4.5	3	●			
Z22.0515.02	22	5.15	5.7	0.15	21.7	5.26*		4.5	3	●			

Weitere HM Sorten können Sie in der Sortenübersicht im Kapitel "Technische Hinweise" und der Preisliste finden.

Bestellbeispiel:  
für Sorte AL41F:  
Z22.0515.02/AL41F

More carbide grades you can find in the grades summary in the chapter "technical instructions" and in the price list.

order-example:  
grade AL41F:  
Z22.0515.02/AL41F



## MINIMILL

Nut- und Formzirkularfräsen

groove milling by circular interpolation

## Typ Z22

Sicherungsringe, DIN 471 / 472 mit Nutaußenkantenfasung

D min. 22 mm

for circlip grooves DIN 471 / 472 with chamfer

D min. 22 mm

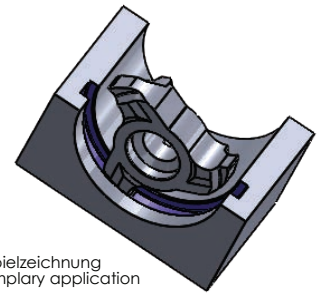
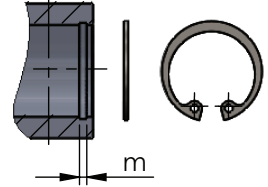
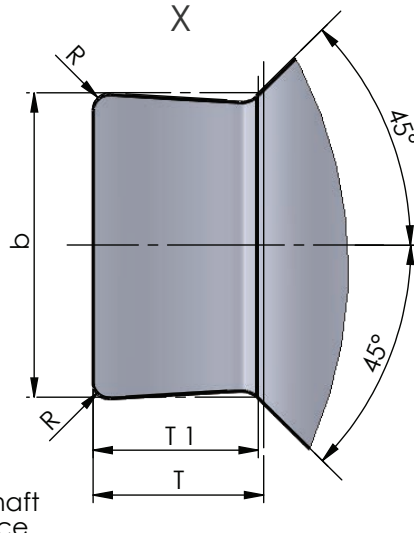
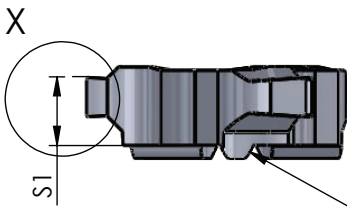
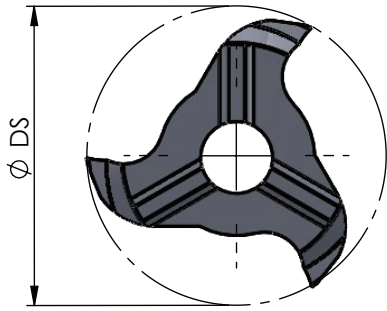

Beispielzeichnung  
exemplary application

Abmessungen in mm

dimensions in mm

Bestellnummer part number	D min.	Nut-Maß m groove dim. m DIN 471 / DIN 472	S1	R	Ø DS	b -0.02	T1 -0.04 Formtiefe depth of form	T	Zähnezahl number of teeth	K10F AL41F P18C	für Fräsertschaft for milling shank
Z22.1105.30	22	1.1	5.0	-	21.7	1.21	0.49	0.50	3	●	ZH22... ZH28...
Z22.1307.30	22	1.3	5.2	-	21.7	1.41	0.67	0.70	3	●	
Z22.1308.30	22	1.3	5.2	-	21.7	1.41	0.83	0.85	3	●	
Z22.1609.35	22	1.6	5.0	-	21.7	1.71	0.83	0.85	3	●	
Z22.1610.35	22	1.6	5.0	-	21.7	1.71	0.95	1.00	3	●	
Z22.1812.35	22	1.85	5.2	0.15	21.7	1.96	1.23	1.25	3	●	
Z22.2215.35	22	2.15	5.3	0.15	21.7	2.26	1.47	1.50	3	●	
Z22.2616.45	22	2.65	5.0	0.15	21.7	2.76	1.47	1.50	3	●	
Z22.2617.45	22	2.65	5.0	0.15	21.7	2.76	1.72	1.75	3	●	
Z22.3118.45	22	3.15	5.3	0.2	21.7	3.26	1.72	1.75	3	●	
Z22.4120.55	22	4.15	5.3	0.2	21.7	4.26	1.97	2.00	3	●	
Z22.4125.55	22	4.15	5.3	0.2	21.7	4.26	2.47	2.50	3	●	

Weitere HM Sorten können Sie in der Sortenübersicht im Kapitel "Technische Hinweise" und der Preisliste finden.

Bestellbeispiel:  
für Sorte AL41F:  
Z22.4125.55/AL41F

More carbide grades you can find in the grades summary in the chapter "technical instructions" and in the price list.

order example:  
grade AL41F:  
Z22.4125.55/AL41F

**BROTECH**

# MINIMILL

Nut- und Formzirkularfräsen

groove milling by circular interpolation

# Typ Z622 / Z622.X

Nutfräsen allgemein

for groove milling general use

D min. 22 mm  
t max. = 4.5

D min. 22 mm  
t max. = 4.5

Z622 geradverzahnt / spur-toothed

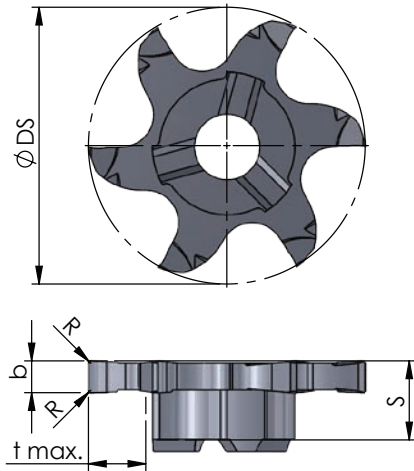

Z622.X kreuzverzahnt / staggered-toothed

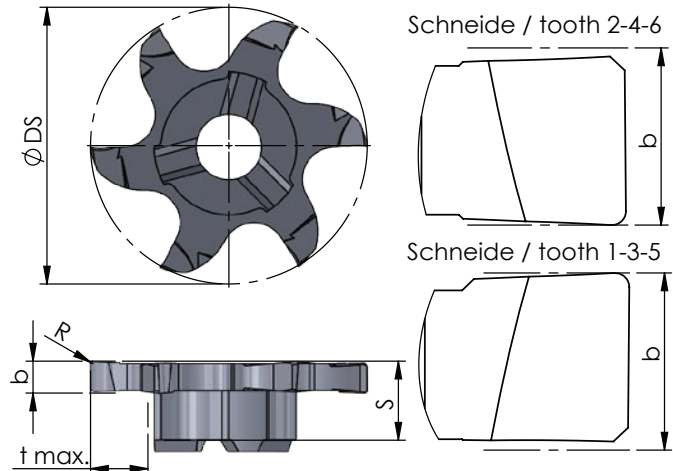

Abmessungen in mm

dimensions in mm



Bestellnummer part number	D min.	S	R	Ø DS	b +0.02	t max.	Zähnezahl number of teeth	Material			für Fräseschaft for milling shank
								K10F	AL41F	P18C	
Z622.0100.01	22	5.8	0.1	21.7	1.0	4.5	6	●			ZH22...
Z622.0150.01	22	6.2	0.1	21.7	1.5	4.5	6	●			
Z622.0200.02	22	6.2	0.2	21.7	2.0	4.5	6	●			
Z622.X200.02	22	6.2	0.2	21.7	2.0	4.5	6	●			
Z622.0250.02	22	6.2	0.2	21.7	2.5	4.5	6	●			
Z622.X250.02	22	6.2	0.2	21.7	2.5	4.5	6	●			
Z622.0300.02	22	6.2	0.2	21.7	3.0	4.5	6	●			
Z622.X300.02	22	6.2	0.2	21.7	3.0	4.5	6	●			
Z622.0400.02	22	6.2	0.2	21.7	4.0	4.5	6	●			
Z622.X400.02	22	6.2	0.2	21.7	4.0	4.5	6	●			

Weitere HM Sorten können Sie in der Sortenübersicht im Kapitel "Technische Hinweise" und der Preisliste finden.

Bestellbeispiel:  
für Sorte AL41F:  
Z622.0150.01/AL41F

More carbide grades you can find in the grades summary in the chapter "technical instructions" and in the price list.

order example:  
grade AL41F:  
Z622.0150.01/AL41F

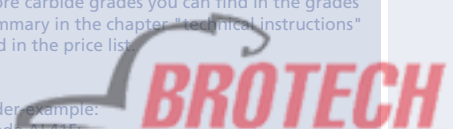

**MINIMILL**

Nut- und Formzirkularfräsen

groove milling by circular interpolation

**Typ Z25**

Nutfräsen allgemein

D min. 25 mm  
t max. = 5.0

for groove milling general use

D min. 25 mm  
t max. = 5.0

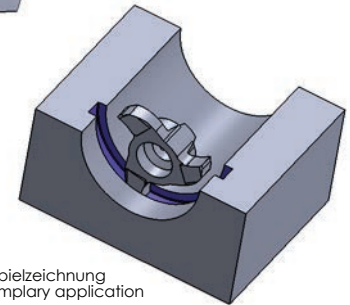
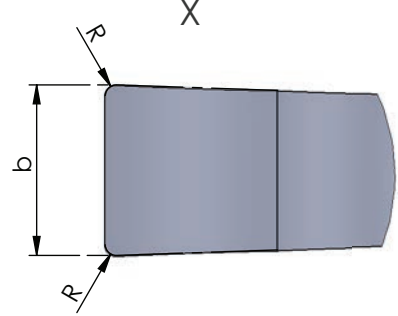
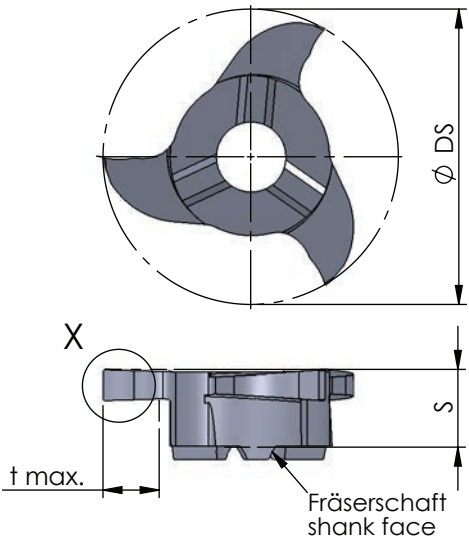

Abmessungen in mm

dimensions in mm

Bestellnummer part number	D min.	S	R	Ø DS	b +0.02	b (inch)	t max.	Zähnezahl number of teeth				für Frälerschaft for milling shank
									K10F	AL41F	P18C	
Z25.0200.02	25	6.6	0.2	24.8	2.0		5.0	3	●			ZH28...
Z25.0250.02	25	6.6	0.2	24.8	2.5		5.0	3	●			
Z25.0300.02	25	6.6	0.2	24.8	3.0		5.0	3	●			
Z25.0318.02	25	6.6	0.2	24.8	3.18	0.125"	5.0	3	●			
Z25.0350.02	25	6.6	0.2	24.8	3.5		5.0	3	●			
Z25.0400.02	25	6.6	0.2	24.8	4.0		5.0	3	●			

Weitere HM Sorten können Sie in der Sortenübersicht im Kapitel "Technische Hinweise" und der Preisliste finden.

Bestellbeispiel:  
für Sorte AL41F:  
Z25.0350.02/AL41F

More carbide grades you can find in the grades summary in the chapter "technical instructions" and in the price list.

order-example:  
grade AL41F:  
Z25.0350.02/AL41F



# MINIMILL

Nut- und Formzirkularfräsen

groove milling by circular interpolation

# Typ Z625.X

Nutfräsen allgemein

general use

D min. 25 mm  
t max. = 5

D min. 25 mm  
t max. = 5

## Z625.X kreuzverzahnt / staggered-toothed

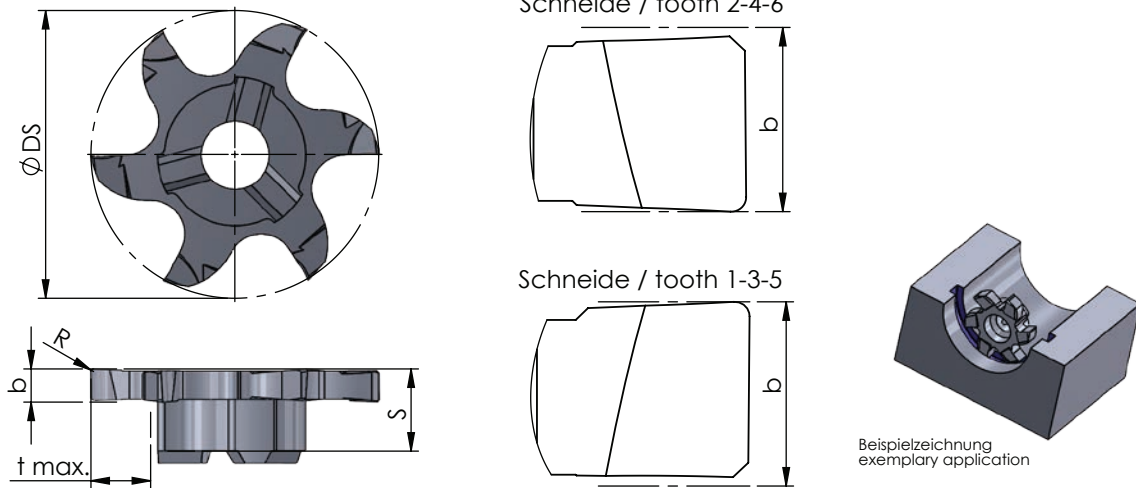

Abmessungen in mm

dimensions in mm

Bestellnummer part number	D min.	S	R	Ø DS	b +0.02	t max.	Zähnezahl number of teeth				für Fräterschaft for milling shank
								K10F	AL41F	P18C	
Z625.X250.02	25	6.4	0.2	24.8	2.5	5.0	6	●			ZH28...
Z625.X300.02	25	6.4	0.2	24.8	3.0	5.0	6	●			
Z625.X400.02	25	6.4	0.2	24.8	4.0	5.0	6	●			
Z625.X500.02	25	6.4	0.2	24.8	5.0	5.0	6	●			
Z625.X600.02	25	6.4	0.2	24.8	6.0	5.0	6	●			

Weitere HM Sorten können Sie in der Sortenübersicht im Kapitel "Technische Hinweise" und der Preisliste finden.

Bestellbeispiel:  
für Sorte AL41F:  
Z625.X250.02/AL41F

More carbide grades you can find in the grades summary in the chapter "technical instructions" and in the price list.

order example:  
grade AL41F:  
Z625.X250.02/AL41F

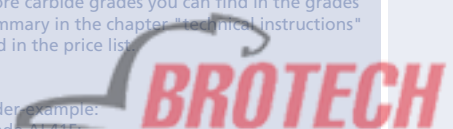



**MINIMILL**

Nut- und Formzirkularfräsen

groove milling by circular interpolation

**Typ Z28**

Nutfräsen allgemein

for groove milling general use

D min. 28 mm  
t max. = 6.5

D min. 28 mm  
t max. = 6.5

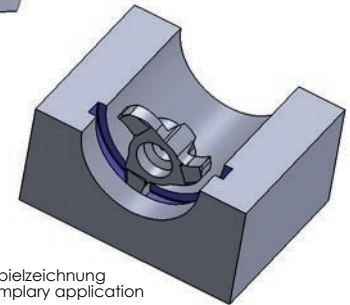
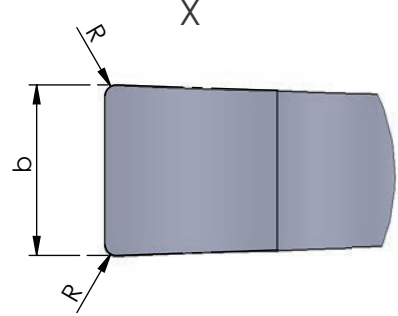
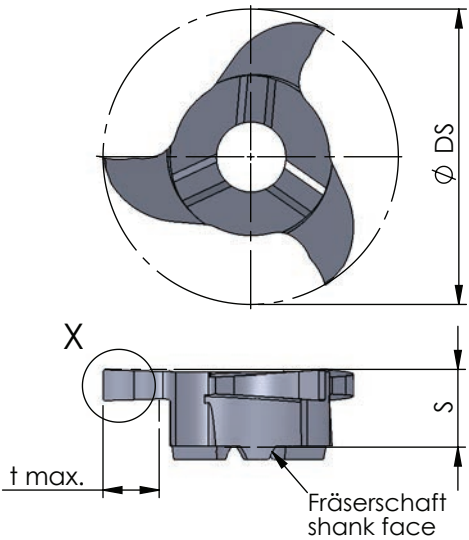

Abmessungen in mm

dimensions in mm

Bestellnummer part number	dimensions in mm							Zähnezahl number of teeth	Material			für Fräseschaft for milling shank
	D min.	S	R	Ø DS	b +0.02	b (inch)	t max.		K10F	AL41F	P18C	
Z28.0150.00	28	6.6	0.2	27.7	1.50		6.5	3	●			ZH28...
Z28.0200.02	28	6.6	0.2	27.7	2.00		6.5	3	●			
Z28.0238.02	28	6.6	0.2	27.7	2.39	0.094"	6.5	3	●			
Z28.0250.02	28	6.6	0.2	27.7	2.50		6.5	3	●			
Z28.0300.02	28	6.6	0.2	27.7	3.00		6.5	3	●			
Z28.0318.02	28	6.6	0.2	27.7	3.18	0.125"	6.5	3	●			
Z28.0350.02	28	6.6	0.2	27.7	3.50		6.5	3	●			
Z28.0400.02	28	6.6	0.2	27.7	4.00		6.5	3	●			
Z28.0475.02	28	6.6	0.2	27.7	4.75	0.187"	6.5	3	●			
Z28.0500.02	28	6.6	0.2	27.7	5.00		6.5	3	●			
Z28.0600.02	28	6.6	0.2	27.7	6.00		6.5	3	●			

Weitere HM Sorten können Sie in der Sortenübersicht im Kapitel "Technische Hinweise" und der Preisliste finden.

Bestellbeispiel:  
für Sorte AL41F:  
Z28.0350.02/AL41F

More carbide grades you can find in the grades summary in the chapter "technical instructions" and in the price list.

order-example:  
grade AL41F:  
Z28.0350.02/AL41F



# MINIMILL

Nut- und Formzirkularfräsen

groove milling by circular interpolation

# Typ Z28

Nutfräsen allgemein

for groove milling general use

D min. 28.3 mm  
t max. = 9.3

D min. 28.3 mm  
t max. = 9.3

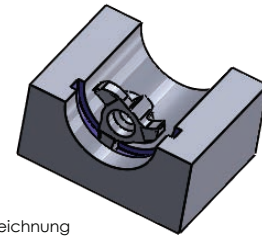
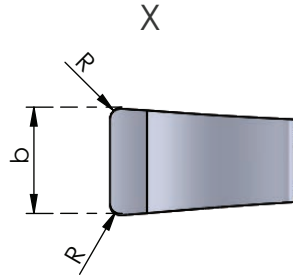
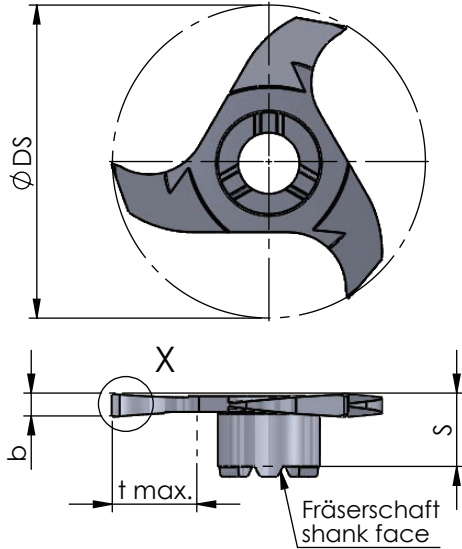

Beispielzeichnung  
exemplary application

Abmessungen in mm

dimensions in mm

Bestellnummer part number	D min.	S	R	Ø DS	b -0.02	t max.	Zähnezahl number of teeth				für Fräterschaft for milling shank
								K10F	AL41F	P18C	
Z28.0150.02.9	28.3	6.5	0.2	28	1.5	9.3	3	●			
Z28.0200.02.9	28.3	6.5	0.2	28	2.0	9.3	3		●		ZH33...
Z28.0250.02.9	28.3	6.5	0.2	28	2.5	9.3	3		●		

Weitere HM Sorten können Sie in der Sortenübersicht im Kapitel "Technische Hinweise" und der Preisliste finden.

Bestellbeispiel:  
für Sorte AL41F:  
Z28.0150.02.9/AL41F

More carbide grades you can find in the grades summary in the chapter "technical instructions" and in the price list.

order example:  
grade AL41F:  
Z28.0150.02.9/AL41F

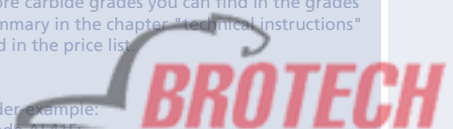

**MINIMILL**

Nut- und Formzirkularfräsen

groove milling by circular interpolation

**Typ Z628 / Z628.X**

Sicherungsringe DIN 471 / 472  
und Nutfräsen allgemein

D min. 28 mm  
t max. = 6.5

for circlip grooves DIN 471 / 472  
and general use

D min. 28 mm  
t max. = 6.5

**Z628 geradverzahnt / spur-toothed**

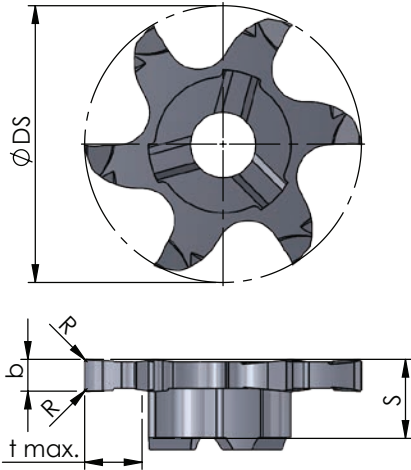

**Z628.X kreuzverzahnt / staggered-toothed**

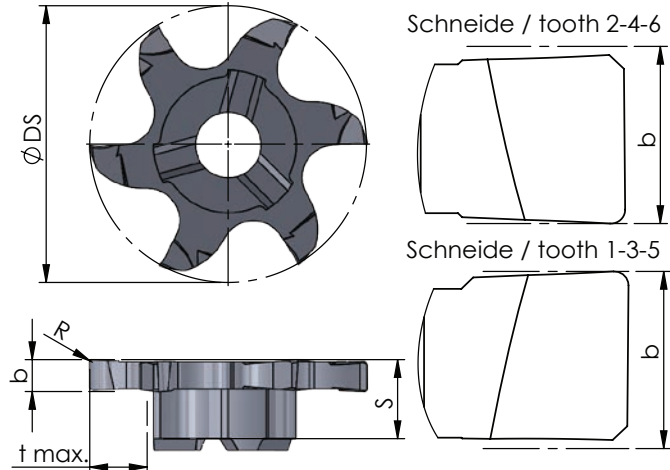

Abmessungen in mm

dimensions in mm

Bestellnummer part number	D min.	Nut-Maß m groove dim. m DIN 471 / DIN 472	S	R	Ø DS	b +0.02 (* b -0.02)	t max.	Zähnezahl number of teeth	K10F AL41F P18C	für Fräsertschaft for milling shank
Z628.0100.01	28	-	6.0	0.1	27.7	1.0	6.5	6	●	ZH28...
Z628.0150.01	28	-	6.4	0.1	27.7	1.5	6.5	6	●	
Z628.0185.02	28	1.85	6.4	0.2	27.7	1.96 *	6.5	6	●	
Z628.0200.02	28	-	6.4	0.2	27.7	2.0	6.5	6	●	
Z628.0215.02	28	2.15	6.2	0.2	27.7	2.26 *	6.5	6	●	
Z628.0250.02	28	-	6.4	0.2	27.7	2.5	6.5	6	●	
Z628.X250.02	28	-	6.2	0.2	27.7	2.5	6.5	6	●	
Z628.0300.02	28	-	6.4	0.2	27.7	3.0	6.5	6	●	
Z628.X300.02	28	-	6.2	0.2	27.7	3.0	6.5	6	●	
Z628.0400.02	28	-	6.4	0.2	27.7	4.0	6.5	6	●	
Z628.X400.02	28	-	6.2	0.2	27.7	4.0	6.5	6	●	
Z628.0500.02	28	-	6.4	0.2	27.7	5.0	6.5	6	●	
Z628.X500.02	28	-	6.2	0.2	27.7	5.0	6.5	6	●	
Z628.0600.02	28	-	6.4	0.2	27.7	6.0	6.5	6	●	
Z628.X600.02	28	-	6.2	0.2	27.7	6.0	6.5	6	●	

Weitere HM Sorten können Sie in der Sortenübersicht im Kapitel "Technische Hinweise" und der Preisliste finden.

Bestellbeispiel:  
für Sorte AL41F: Z628.0150.01/AL41F

More carbide grades you can find in the grades summary in the chapter "technical instructions" and in the price list.

order-example:  
grade AL41F: Z628.0150.01/AL41F

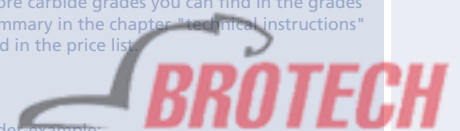

# MINIMILL

Nut- und Formzirkularfräsen

groove milling by circular interpolation

# Typ Z628

Nutfräsen allgemein

for groove milling general use

D min. 28 mm  
t max. = 9.3

D min. 28 mm  
t max. = 9.3

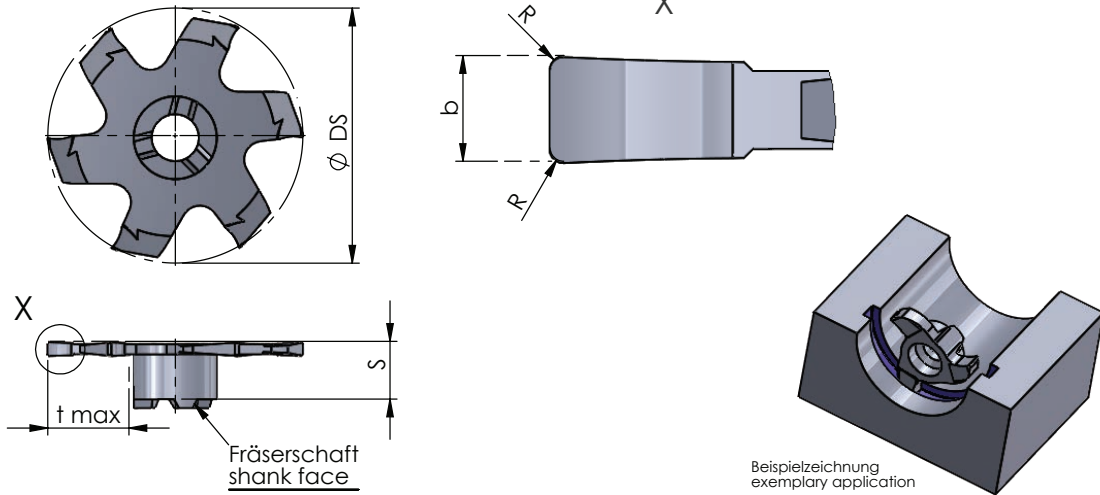

Abmessungen in mm

dimensions in mm

Bestellnummer part number	D min.	S	R	$\varnothing DS$	b +0.02	t max.	Zähnezahl number of teeth	K10F AL41F P18C	für Fräseschaft for milling shank
Z628.150.02.9	28	6.2	0.2	27.7	1.5	9.3	6	●	ZH33...

Weitere HM Sorten können Sie in der Sortenübersicht im Kapitel "Technische Hinweise" und der Preisliste finden.

Bestellbeispiel:  
für Sorte AL41F:  
Z628.150.02.9/AL41F

More carbide grades you can find in the grades summary in the chapter "technical instructions" and in the price list.

order example:  
grade AL41F:  
Z628.150.02.9/AL41F



**MINIMILL**

Nut- und Formzirkularfräsen

groove milling by circular interpolation

**Typ Z32**

Nutfräsen allgemein

for groove milling general use

D min. 32 mm  
t max. = 8.5

D min. 32 mm  
t max. = 8.5

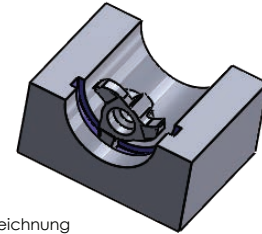
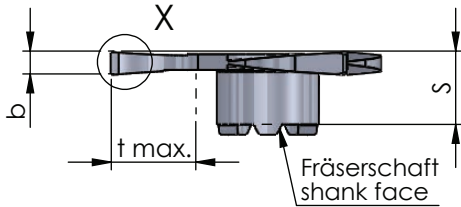
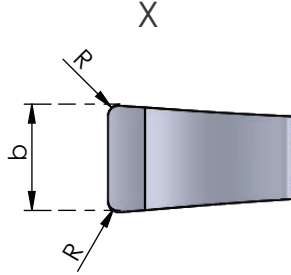
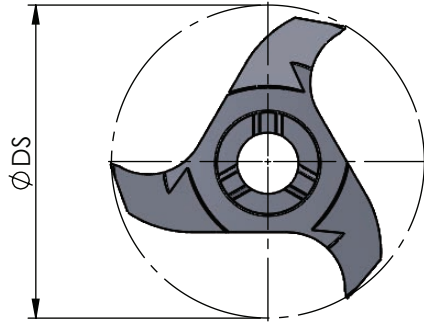

Beispielzeichnung  
exemplary application

Abmessungen in mm

dimensions in mm

Bestellnummer part number	D min.	S	R	Ø DS	b +0.02	t max.	Zähnezahl number of teeth				für Fräseschaft for milling shank
								K10F	AL41F	P18C	
Z32.0200.00	32	6.5	0.2	31.7	2.0	8.5	3	●			
Z32.0250.02	32	6.5	0.2	31.7	2.5	8.5	3	●			ZH28...
Z32.0300.02	32	6.5	0.2	31.7	3.0	8.5	3	●			

Weitere HM Sorten können Sie in der Sortenübersicht im Kapitel "Technische Hinweise" und der Preisliste finden.

Bestellbeispiel:  
für Sorte AL41F:  
Z32.0300.02/AL41F

More carbide grades you can find in the grades summary in the chapter "technical instructions" and in the price list.

order example:  
grade AL41F:  
Z32.0300.02/AL41F



# MINIMILL

Nut- und Formzirkularfräsen

groove milling by circular interpolation

# Typ Z33

Nutfräsen allgemein

for groove milling general use

D min. 33 / 33.9 mm  
t max. = 10 / 12

D min. 33 / 33.9 mm  
t max. = 10 / 12

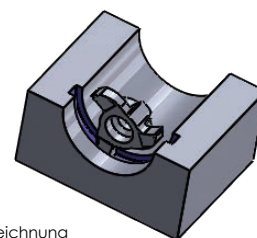
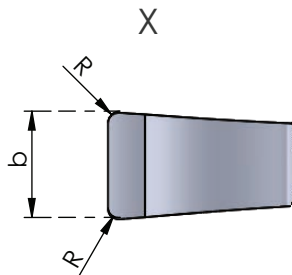
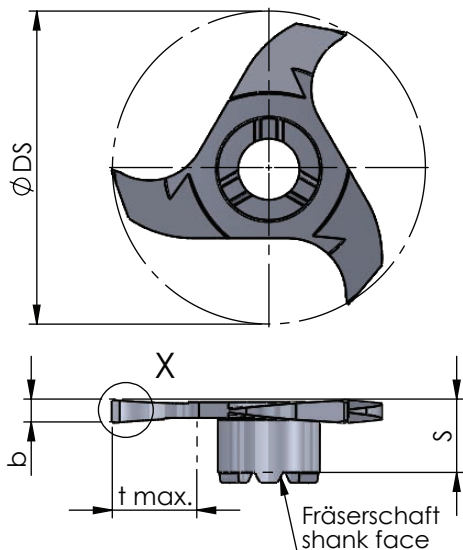

Beispielzeichnung  
exemplary application

Abmessungen in mm

dimensions in mm

Bestellnummer part number	D min.	S	R	Ø DS	b -0.02	t max.	Zähnezahl number of teeth	Material			für Frälerschaft for milling shank
								K10F	AL41F	P18C	
Z33.110.42.10	33	6.5	0.2	32.7	1.10	10	3	●			ZH22...
Z33.120.42.10	33	6.5	0.2	32.7	1.20	10	3	●			
Z33.132.42.10	33	6.5	0.2	32.7	1.32	10	3	●			
Z33.150.42.10	33	6.5	0.2	32.7	1.50	10	3	●			
Z33.160.42.10	33	6.5	0.2	32.7	1.60	10	3	●			
Z33.170.42.10	33	6.5	0.2	32.7	1.70	10	3	●			
Z33.200.42.10	33	6.5	0.2	32.7	2.00	10	3	●			
Z33.250.42.10	33	6.5	0.2	32.7	2.50	10	3	●			
Z33.170.42.12	33.9	6.5	0.2	33.6	1.70	12	3	●			ZH33...

Weitere HM Sorten können Sie in der Sortenübersicht im Kapitel "Technische Hinweise" und der Preisliste finden.

Bestellbeispiel:  
für Sorte AL41F:  
Z33.200.42.10/AL41F

More carbide grades you can find in the grades summary in the chapter "technical instructions" and in the price list.

order example:  
grade AL41F:  
Z33.200.42.10/AL41F



## MINIMILL

Nut- und Formzirkularfräsen

groove milling by circular interpolation

## Typ Z635 / Z635.X

Nutfräsen allgemein

for groove milling general use

D min. 35 mm  
t max. = 10

D min. 35 mm  
t max. = 10

Z635 geradverzahnt / spur-toothed

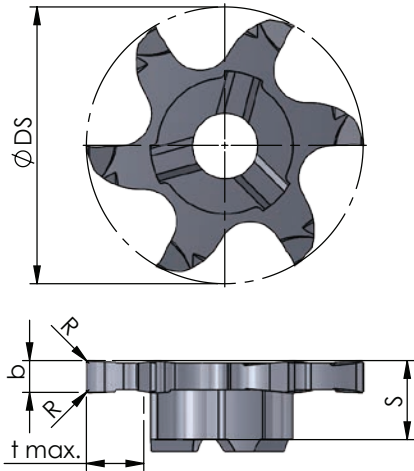

Z635.X kreuzverzahnt / staggered-toothed

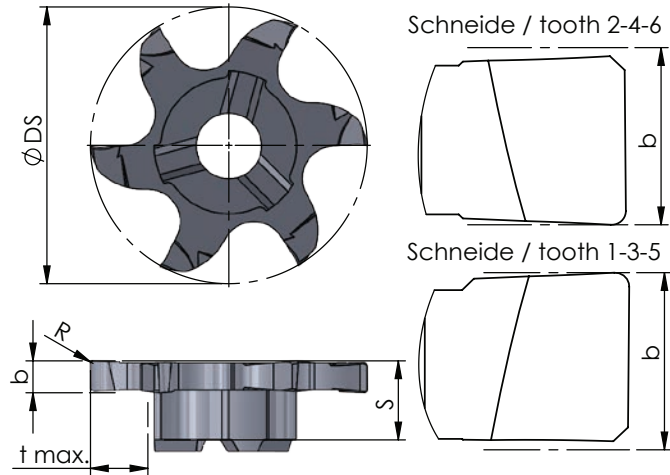

Abmessungen in mm

dimensions in mm

Bestellnummer part number	D min.	S	R	Ø DS	b +0.02	t max.	Zähnezahl number of teeth	K10F AL41F P18C	für Fräterschaft for milling shank
Z635.0150.01	35	6.25	0.1	34.7	1.5	10.0	6	●	ZH28...
Z635.0200.02	35	6.25	0.2	34.7	2.0	10.0	6	●	
Z635.X200.02	35	6.25	0.2	34.7	2.0	10.0	6	●	
Z635.0250.02	35	6.25	0.2	34.7	2.5	10.0	6	●	
Z635.X250.02	35	6.25	0.2	34.7	2.5	10.0	6	●	
Z635.0300.02	35	6.25	0.2	34.7	3.0	10.0	6	●	
Z635.X300.02	35	6.25	0.2	34.7	3.0	10.0	6	●	

Weitere HM Sorten können Sie in der Sortenübersicht im Kapitel "Technische Hinweise" und der Preisliste finden.

Bestellbeispiel:  
für Sorte AL41F:  
Z635.0150.01/AL41F

More carbide grades you can find in the grades summary in the chapter "technical instructions" and in the price list.

order example:  
grade AL41F:  
Z635.0150.01/AL41F

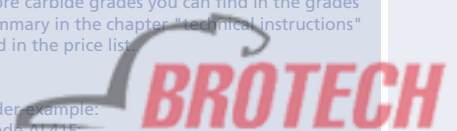

# MINIMILL

Nut- und Formzirkularfräsen

groove milling by circular interpolation

# Typ Z637 / Z637X / Z640

Nutfräsen allgemein

for groove milling general use

D min. 37 / 40 mm  
t max. = 12 / 13.5

D min. 37 / 40 mm  
t max. = 12 / 13.5



## Z637/Z640 geradverzahnt / spur-toothed

## Z637.X kreuzverzahnt / staggered-toothed

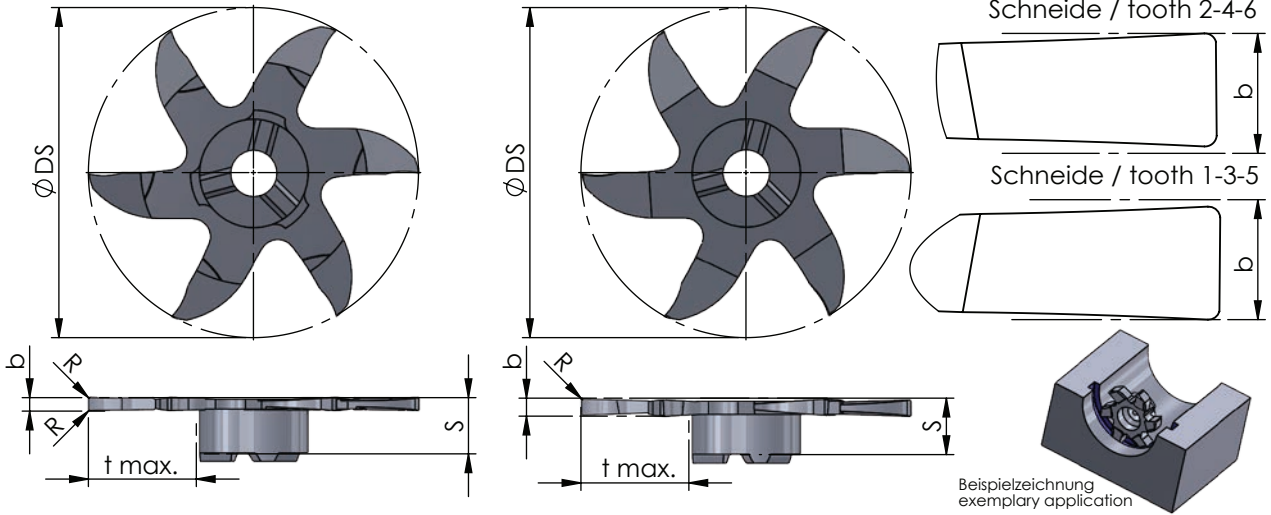

Beispielzeichnung  
exemplary application

Abmessungen in mm

dimensions in mm

Bestellnummer part number	D min.	S	R	Ø DS	b +0.02	t max.	Zähnezahl number of teeth	Material			für Fräseschaft for milling shank
								K10F	AL41F	P18C	
Z637.0100.01	37	6.25	0.1	36.7	1.0	12.0	6	●			ZH22...
Z640.0100.01	40	6.25	0.1	39.7	1.0	13.5	6	●			
Z637.0150.01	37	6.25	0.1	36.7	1.5	12.0	6	●			
Z637.X150.01	37	6.25	0.1	36.7	1.5	12.0	6	●			
Z640.0150.01	40	6.25	0.1	39.7	1.5	13.5	6	●			
Z637.X200.02	37	6.25	0.2	36.7	2.0	12.0	6	●			

Weitere HM Sorten können Sie in der Sortenübersicht im Kapitel "Technische Hinweise" und der Preisliste finden.

Bestellbeispiel:  
für Sorte AL41F:  
Z637.0100.01/AL41F

More carbide grades you can find in the grades summary in the chapter "technical instructions" and in the price list.

order example:  
grade AL41F:  
Z637.0100.01/AL41F

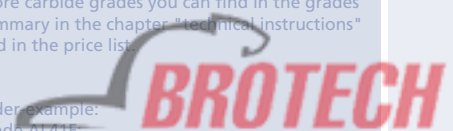



**MINIMILL**

Nut- und Formzirkularfräsen

groove milling by circular interpolation

**Typ Z637 / Z640**

Nutfräsen, Trennfräsen und Schlitzfräsen  
b = 0.4 - 0.8 mm

for groove and key way milling  
b = 0.4 - 0.8 mm

D min. 37 / 40 mm  
t max. = 12 / 13.5

D min. 37 / 40 mm  
t max. = 12 / 13.5

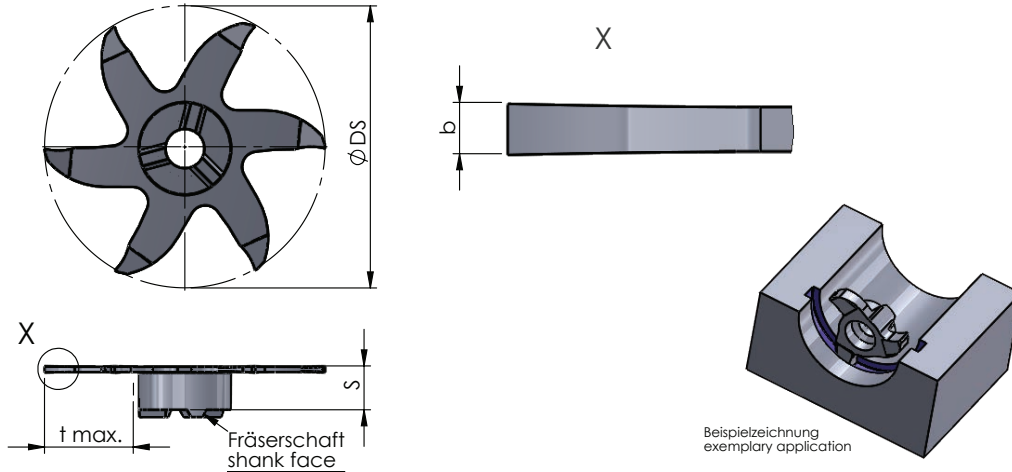

Abmessungen in mm

dimensions in mm

Bestellnummer part number	D min.	S	Ø DS	b +0.05	t max.	Zähnezahl number of teeth				für Fräaserschaft for milling shank
							K10F	AL41F	P18C	
Z640.0040.00	40	6.0	39.7	0.4	13.5	6		●		ZH22...
Z637.0050.00	37	6.0	36.7	0.5	12.0	6		●		
Z640.0050.00	40	6.0	39.7	0.5	13.5	6		●		
Z637.0060.00	37	5.7	36.7	0.6	12.0	6		●		
Z640.0060.00	40	5.7	39.7	0.6	13.5	6		●		
Z637.0080.00	37	6.0	36.7	0.8	12.0	6		●		
Z640.0080.00	40	6.0	39.7	0.8	13.5	6		●		

Weitere HM Sorten können Sie in der Sortenübersicht im Kapitel "Technische Hinweise" und der Preisliste finden.

Bestellbeispiel:  
für Sorte AL41F:  
Z637.0050.00/AL41F

More carbide grades you can find in the grades summary in the chapter "technical instructions" and in the price list.

order example:  
grade AL41F:  
Z637.0050.00/AL41F



# MINIMILL

Nut- und Formzirkularfräsen

groove milling by circular interpolation

# Typ Z12

Vollradius

full radius

D min. 12 mm  
t max. = 2.5

D min. 12 mm  
t max. = 2.5

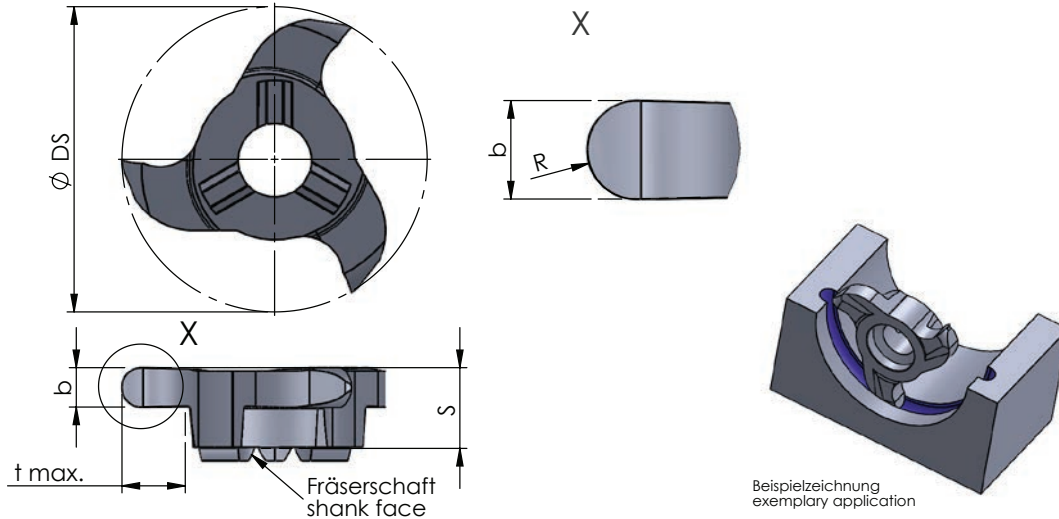

Abmessungen in mm

dimensions in mm

Bestellnummer part number	D min.	S	R	$\varnothing DS$	b +0.03	t max.	Zähnezahl number of teeth	Material			für Fräterschaft for milling shank
								K10F	AL41F	P18C	
Z12.0011.22	12	3.5	1.1	11.7	2.2	2.5	3		●		ZH10...

Weitere HM Sorten können Sie in der Sortenübersicht im Kapitel "Technische Hinweise" und der Preisliste finden.

Bestellbeispiel:  
für Sorte AL41F:  
Z12.0011.22/AL41F

More carbide grades you can find in the grades summary in the chapter "technical instructions" and in the price list.

order example:  
grade AL41F:  
Z12.0011.22/AL41F



**MINIMILL**

Nut- und Formzirkularfräsen

groove milling by circular interpolation

**Typ Z16**

Vollradius

full radius

D min. 16 mm  
t max. = 3.5

D min. 16 mm  
t max. = 3.5

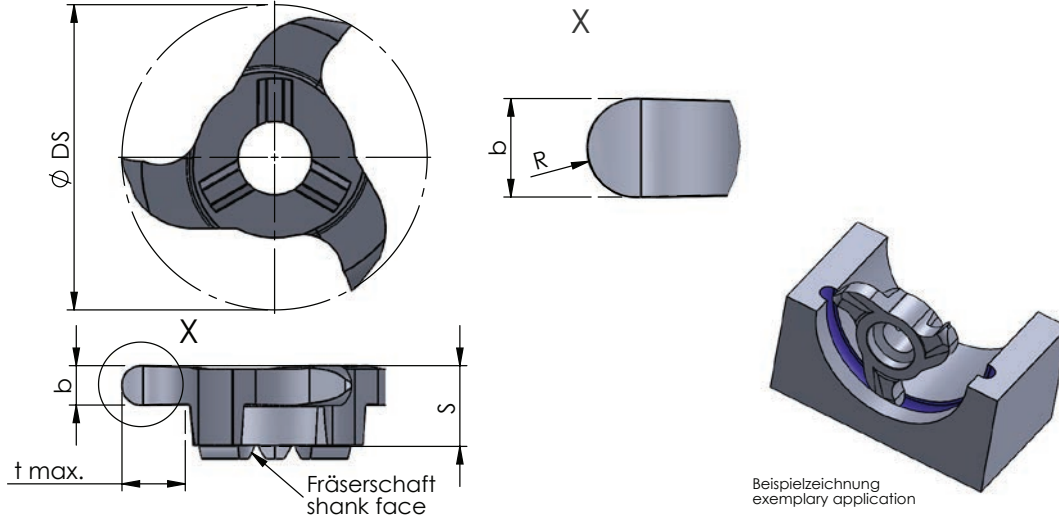

Abmessungen in mm

dimensions in mm

Bestellnummer part number	D min.	S	R	$\varnothing DS$	b +0.03	t max.	Zähnezahl number of teeth	Material			für Fräterschaft for milling shank
								K10F	AL41F	P18C	
Z16.0011.22	16	4.5	1.1	15.7	2.2	3.5	3	●			ZH14...

Weitere HM Sorten können Sie in der Sortenübersicht im Kapitel "Technische Hinweise" und der Preisliste finden.

Bestellbeispiel:  
für Sorte AL41F:  
Z16.0011.22/AL41F

More carbide grades you can find in the grades summary in the chapter "technical instructions" and in the price list.

order example:  
grade AL41F:  
Z16.0011.22/AL41F

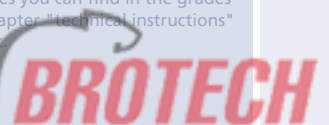

# MINIMILL

Nut- und Formzirkularfräsen

groove milling by circular interpolation

# Typ Z18

Vollradius

D min. 18 mm  
t max. = 3.5

full radius

D min. 18 mm  
t max. = 3.5

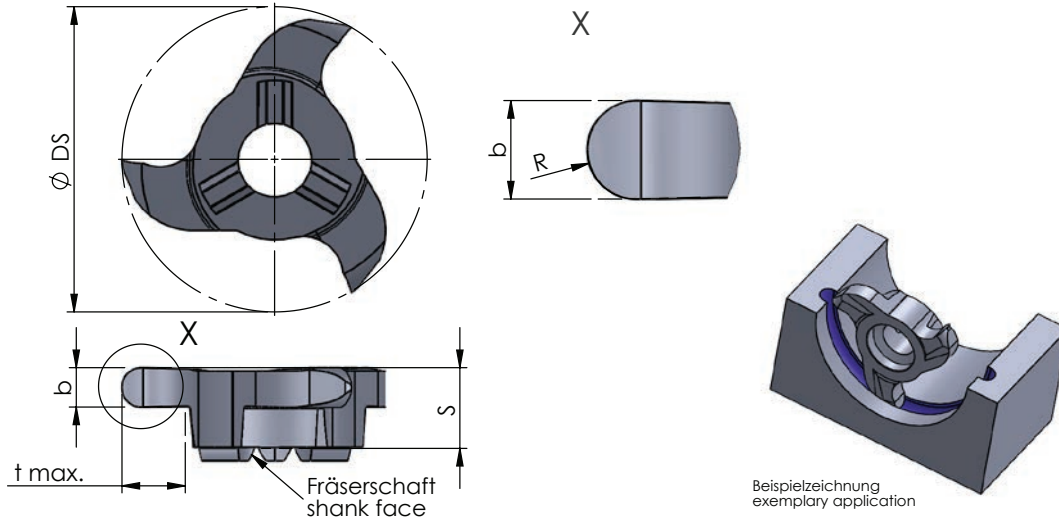

Abmessungen in mm

dimensions in mm

Bestellnummer part number	D min.	S	R	Ø DS	b +0.03	b (inch)	t max.	Zähnezahl number of teeth				für Fräterschaft for milling shank
									K10F	AL41F	P18C	
Z18.0010.20	18	5.75	1.0	17.7	2.0		3.5	3	●			ZH18...
Z18.0011.22	18	5.75	1.1	17.7	2.2		3.5	3		●		
Z18.U011.23	18	5.75	1.19	17.7	2.38	0.094"	3.5	3	●	●		
Z18.0015.30	18	5.75	1.5	17.7	3.0		3.5	3		●		

Weitere HM Sorten können Sie in der Sortenübersicht im Kapitel "Technische Hinweise" und der Preisliste finden.

Bestellbeispiel:  
für Sorte AL41F:  
Z18.0010.20/AL41F

More carbide grades you can find in the grades summary in the chapter "technical instructions" and in the price list.

order-example:  
grade AL41F:  
Z18.0010.20/AL41F



**MINIMILL**

Nut- und Formzirkularfräsen

groove milling by circular interpolation

**Typ Z22**

Vollradius

D min. 22 mm  
t max. = 4.5

full radius

D min. 22 mm  
t max. = 4.5

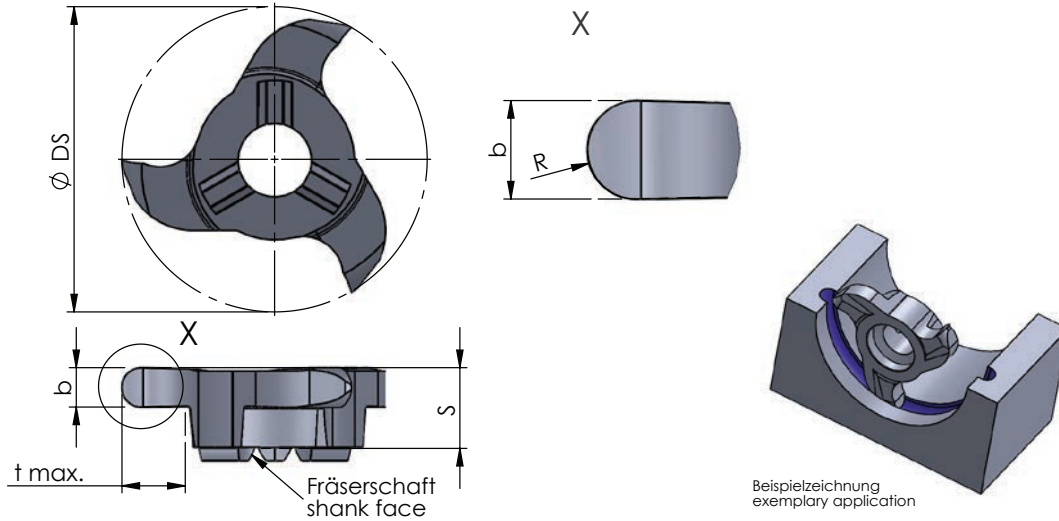

Abmessungen in mm

dimensions in mm

Bestellnummer part number	D min.	S	R	Ø DS	b +0.03	b (inch)	t max.	Zähnezahl number of teeth				für Fräseschaft for milling shank
									K10F	AL41F	P18C	
Z22.0005.10	22	5.75	0.5	21.7	1.0		4.5	3				ZH22...
Z22.0008.16	22	5.75	0.8	21.7	1.6		4.5	3				
Z22.0010.20	22	5.75	1.0	21.7	2.0		4.5	3	●			
Z22.0012.24	22	5.75	1.2	21.7	2.4		4.5	3		●		
Z22.0014.28	22	5.75	1.4	21.7	2.8		4.5	3		●		
Z22.0015.30	22	5.75	1.5	21.7	3.0		4.5	3		●		
Z22.U015.31	22	5.75	1.57	21.7	3.17	0.125"	4.5	3		●		
Z22.0020.40	22	5.75	2.0	21.7	4.0		4.5	3		●		
Z22.0022.44	22	5.75	2.2	21.7	4.4		4.5	3		●		
Z22.0025.50	22	5.75	2.5	21.7	5.0		4.5	3		●		

Weitere HM Sorten können Sie in der Sortenübersicht im Kapitel "Technische Hinweise" und der Preisliste finden.

Bestellbeispiel:  
für Sorte AL41F:  
Z22.0025.50/AL41F

More carbide grades you can find in the grades summary in the chapter "technical instructions" and in the price list.

order-example:  
grade AL41F:  
Z22.0025.50/AL41F



## MINIMILL

Nut- und Formzirkularfräsen

groove milling by circular interpolation

## Impressionen

impressions



## MINIMILL

Nut- und Formzirkularfräsen

groove milling by circular interpolation

## Typ Z610

metrisches ISO-Gewinde, Teilprofil, innen

metric ISO-thread, partial profile, internal

ab Gewindegröße M12 x 1.0

starting at thread size M12 x 1.0

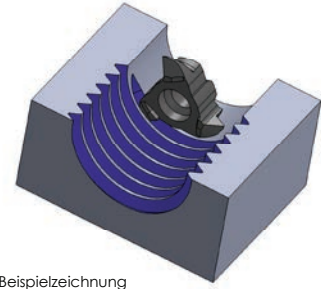
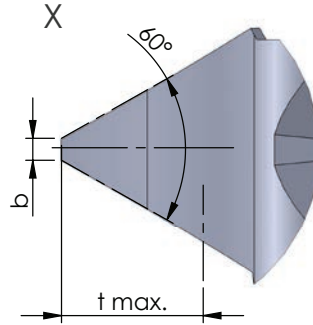
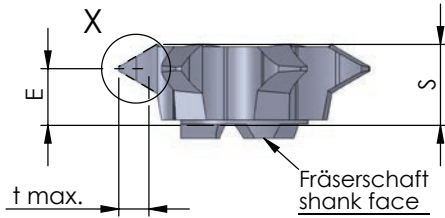
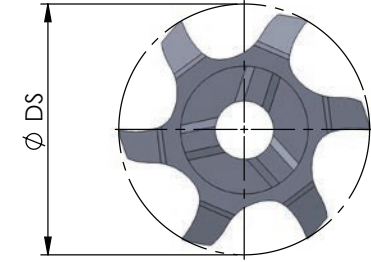

Beispielzeichnung  
exemplary application

Abmessungen in mm

dimensions in mm

Bestellnummer part number	min. Gewindegröße min. thread size	Steigung P pitch P	S	E	Ø DS	b	t max.	Zähnezahl number of teeth	K10F AL41F P18C	für Fräaserschaft for milling shank
Z610.0510.01	M12	1.0-1.75	3.2	2.4	9.8	0.13	1.08	6	●	ZH10...
Z610.0720.01	M14	1.0-2.0	3.2	2.2	10.1	0.13	1.25	6	●	
Z610.0815.01	M16	1.5-2.75	3.2	2.0	11.0	0.19	1.67	6	●	
Z610.2530.01	M16	2.0-3.0	3.2	1.9	11.1	0.25	1.78	6	●	

Weitere HM Sorten können Sie in der Sortenübersicht im Kapitel "Technische Hinweise" und der Preisliste finden.

Bestellbeispiel:  
für Sorte AL41F:  
Z610.0510.01/AL41F

More carbide grades you can find in the grades summary in the chapter "technical instructions" and in the price list.

order example:  
grade AL41F:  
Z610.0510.01/AL41F

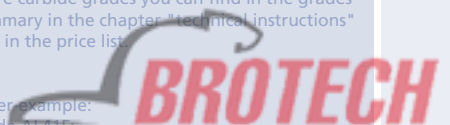

# MINIMILL

Nut- und Formzirkularfräsen

groove milling by circular interpolation

# Typ Z10

metrisches ISO-Gewinde, Vollprofil, innen

metric ISO-thread, full profile, internal

ab Gewindegröße M12 x 0.75

starting at thread size M12 x 0.75

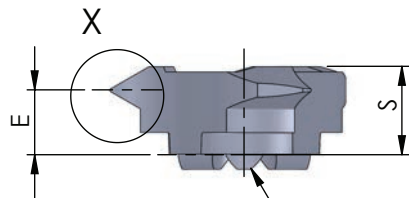
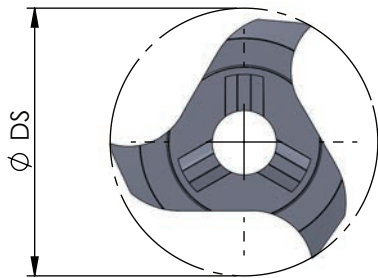

Fräseschaft  
shank face

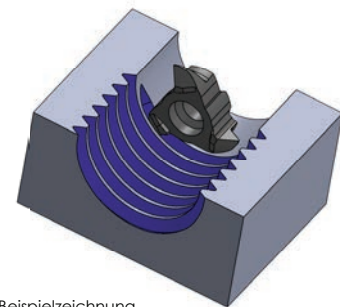
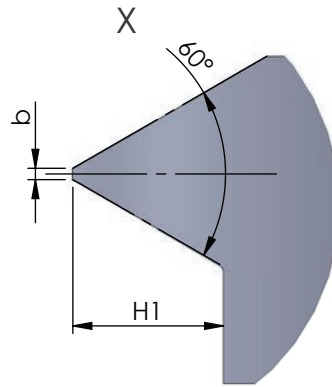

Beispielzeichnung  
exemplary application

Abmessungen in mm

dimensions in mm



Bestellnummer part number	min. Gewindegröße min. thread size	Steigung P pitch P	S	E	Ø DS	b	H1	Zähnezahl number of teeth	K10F AL41F P18C	für Fräseschaft for milling shank
Z10.0407.02	M12	0.75	3.6	3.1	9.7	0.09	0.41	3	●	ZH10...
Z10.0510.02	M12	1.00	3.6	3.0	9.7	0.13	0.54	3	●	
Z10.0815.02	M14	1.50	3.6	2.8	9.7	0.19	0.81	3	●	
Z10.0917.02	M14	1.75	3.6	2.7	9.7	0.20	0.95	3	●	
Z10.1020.02	M14	2.00	3.6	2.6	9.7	0.25	1.08	3	●	
Z10.1325.02	M16	2.50	3.6	2.4	9.7	0.31	1.35	3	●	

Weitere HM Sorten können Sie in der Sortenübersicht im Kapitel "Technische Hinweise" und der Preisliste finden.

Bestellbeispiel:  
für Sorte AL41F:  
Z10.0407.02/AL41F

More carbide grades you can find in the grades summary in the chapter "technical instructions" and in the price list.

order example:  
grade AL41F:  
Z10.0407.02/AL41F





**MINIMILL**

Nut- und Formzirkularfräsen

groove milling by circular interpolation

**Typ Z12**

metrisches ISO-Gewinde, Teilprofil, innen

metric ISO-thread, partial profile, internal

ab Gewindegröße M14 x 1.0

starting at thread size M14 x 1.0

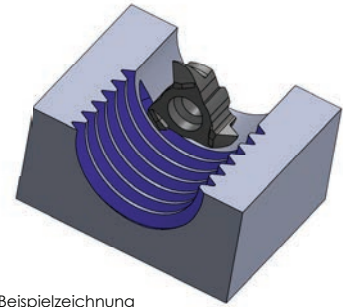
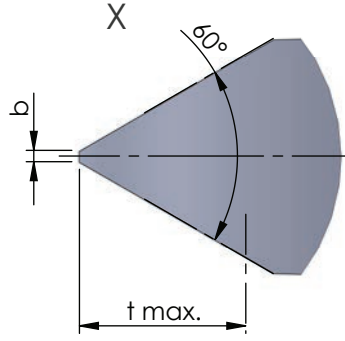
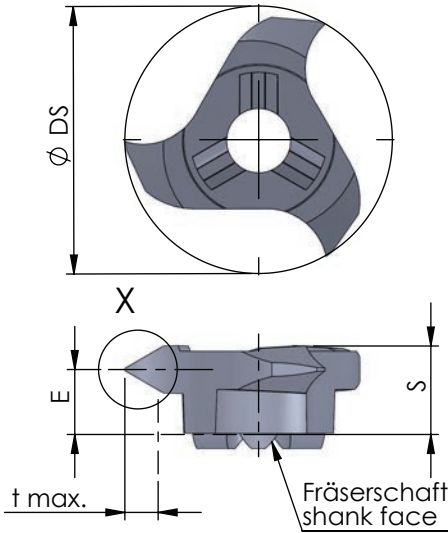

Beispielzeichnung  
exemplary application

Abmessungen in mm

dimensions in mm

Bestellnummer part number	min. Gewindegröße min. thread size	Steigung P pitch P	S	E	Ø DS	b	t max.	Zähnezahl number of teeth	K10F AL41F P18C	für Fräaserschaft for milling shank
Z12.0510.01	M14	1.0-1.75	3.6	2.8	11.7	0.13	1.08	3	●	ZH10...
Z12.0720.01	M14	1.0-2.0	3.6	2.8	11.7	0.13	1.25	3	●	
Z12.0815.01	M16	1.5-2.75	3.6	2.4	11.7	0.19	1.67	3	●	
Z12.2530.01	M16	2.0-3.0	3.6	2.2	11.7	0.25	1.78	3	●	

Weitere HM Sorten können Sie in der Sortenübersicht im Kapitel "Technische Hinweise" und der Preisliste finden.

Bestellbeispiel:  
für Sorte AL41F:  
Z12.0510.01/AL41F

More carbide grades you can find in the grades summary in the chapter "technical instructions" and in the price list.

order example:  
grade AL41F:  
Z12.0510.01/AL41F



# MINIMILL

Nut- und Formzirkularfräsen

groove milling by circular interpolation

# Typ Z614

metrisches ISO-Gewinde, Teilprofil, innen

metric ISO-thread, partial profile, internal

ab Gewindegröße M16 x 1.0

starting at thread size M16 x 1.0

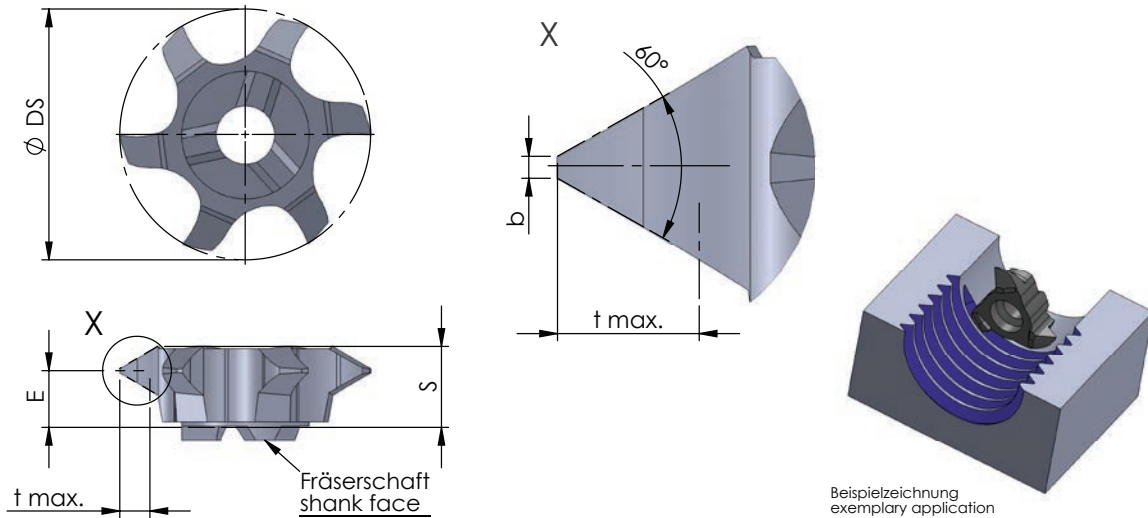

Abmessungen in mm

dimensions in mm

Bestellnummer part number	min. Gewindegröße min. thread size	Steigung P pitch P	S	E	$\varnothing DS$	b	t max.	Zähnezahl number of teeth	K10F AL41F P18C	für Fräaserschaft for milling shank
Z614.0510.01	M16	1.0-1.75	4.2	3.4	12.0	0.13	1.08	6	●	ZH14...
Z614.0720.01	M16	1.0-2.0	4.2	3.6	12.3	0.13	1.25	6	●	
Z614.0815.01	M18	1.5-2.75	4.2	3.0	13.2	0.19	1.67	6	●	
Z614.2530.01	M18	2.0-3.0	4.2	2.8	13.3	0.25	1.78	6	●	

Weitere HM Sorten können Sie in der Sortenübersicht im Kapitel "Technische Hinweise" und der Preisliste finden.

Bestellbeispiel:  
für Sorte AL41F:  
Z614.0510.01/AL41F

More carbide grades you can find in the grades summary in the chapter "technical instructions" and in the price list.

order example:  
grade AL41F:  
Z614.0510.01/AL41F



**MINIMILL**

Nut- und Formzirkularfräsen

groove milling by circular interpolation

**Typ Z14**

metrisches ISO-Gewinde, Vollprofil, innen

metric ISO-thread, full profile, internal

ab Gewindegröße M16 x 1.0

starting at thread size M16 x 1.0

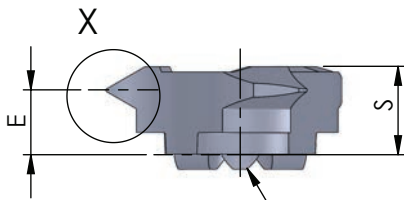
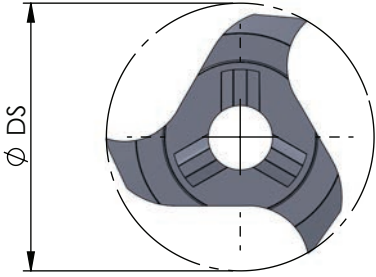

Fräseschaft  
shank face

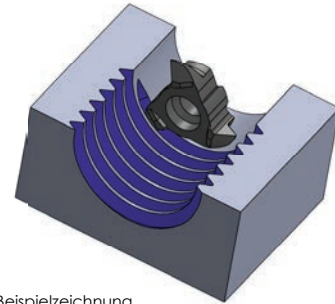
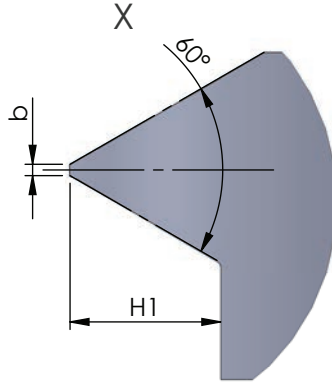

Beispielzeichnung  
exemplary application

Abmessungen in mm

dimensions in mm

Bestellnummer part number	min. Gewindegröße min. thread size	Steigung P pitch P	S	E	Ø DS	b	H1	Zähnezahl number of teeth	K10F AL41F P18C	für Fräseschaft for milling shank
Z14.0510.02	M16	1.00	4.5	3.6	13.7	0.13	0.54	3	●	ZH14...
Z14.0815.02	M18	1.50	4.5	3.5	13.7	0.19	0.81	3	●	
Z14.0917.02	M18	1.75	4.5	3.4	13.7	0.20	0.95	3	●	
Z14.1020.02	M18	2.00	4.5	3.3	13.7	0.25	1.08	3	●	
Z14.1325.02	M20	2.50	4.5	3.1	13.7	0.31	1.35	3	●	
Z14.1630.02	M22	3.00	4.5	2.9	13.7	0.37	1.62	3	●	

Weitere HM Sorten können Sie in der Sortenübersicht im Kapitel "Technische Hinweise" und der Preisliste finden.

Bestellbeispiel:  
für Sorte AL41F:  
Z14.0510.02/AL41F

More carbide grades you can find in the grades summary in the chapter "technical instructions" and in the price list.

order example:  
grade AL41F:  
Z14.0510.02/AL41F



# MINIMILL

Nut- und Formzirkularfräsen

groove milling by circular interpolation

# Typ Z16

metrisches ISO-Gewinde, Teilprofil, innen

metric ISO-thread, partial profile, internal

ab Gewindegröße M18 x 1.0

starting at thread size M18 x 1.0

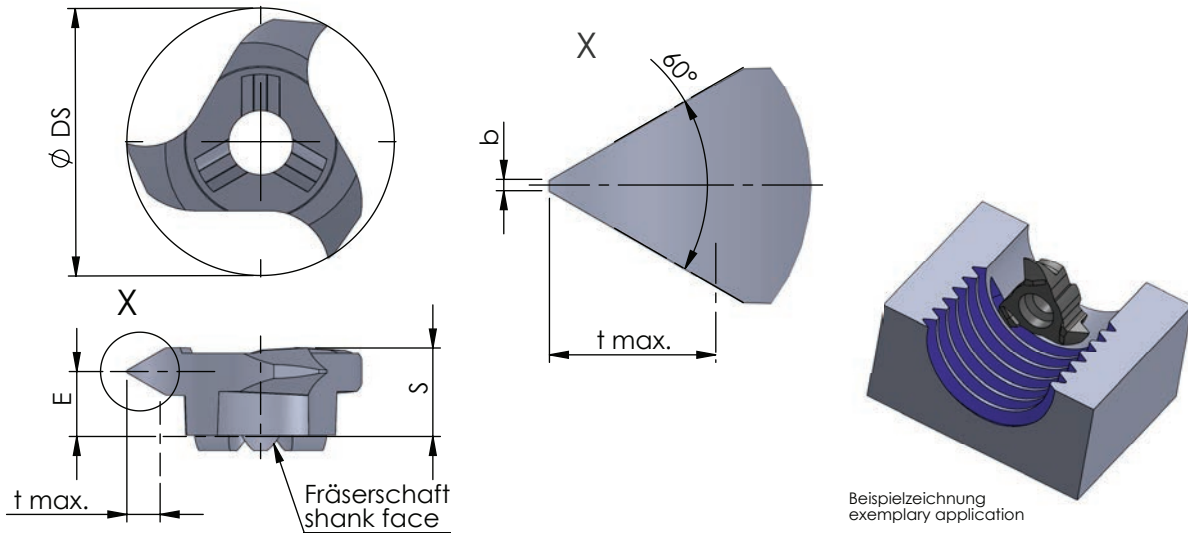

Abmessungen in mm

dimensions in mm

Bestellnummer part number	min. Gewindegröße min. thread size	Steigung P pitch P	S	E	$\varnothing DS$	b	t max.	Zähnezahl number of teeth	K10F AL41F P18C	für Fräaserschaft for milling shank
Z16.0510.01	M18	1.0-1.75	4.6	3.8	15.7	0.12	1.08	3	●	ZH14...
Z16.0720.01	M18	1.0-2.0	4.6	3.5	15.7	0.12	1.25	3	●	
Z16.0815.01	M20	1.5-2.75	4.6	3.5	15.7	0.19	1.67	3	●	
Z16.2530.01	M22	2.5-3.0	4.6	3.4	15.7	0.31	1.78	3	●	

Weitere HM Sorten können Sie in der Sortenübersicht im Kapitel "Technische Hinweise" und der Preisliste finden.

Bestellbeispiel:  
für Sorte AL41F:  
Z16.0510.01/AL41F

More carbide grades you can find in the grades summary in the chapter "technical instructions" and in the price list.

order example:  
grade AL41F:  
Z16.0510.01/AL41F



**MINIMILL**

Nut- und Formzirkularfräsen

groove milling by circular interpolation

**Typ Z18**

metrisches ISO-Gewinde, Teilprofil, innen

metric ISO-thread, partial profile, internal

ab Gewindegröße M22 x 1.0

starting at thread size M22 x 1.0

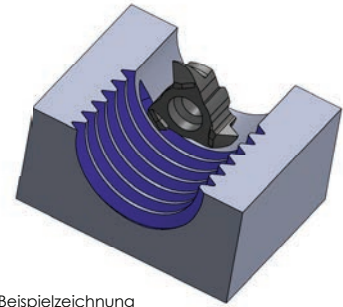
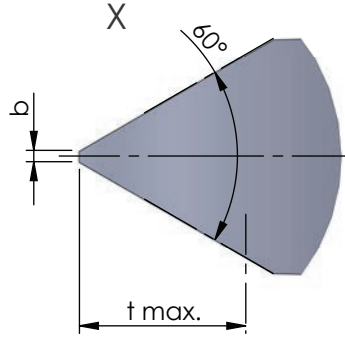
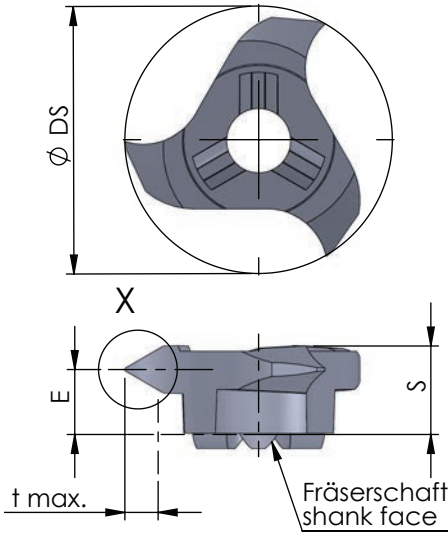

Beispielzeichnung  
exemplary application

Abmessungen in mm

dimensions in mm

Bestellnummer part number	min. Gewindegröße min. thread size	Steigung P pitch P	S	E	Ø DS	b	t max.	Zähnezahl number of teeth	K10F AL41F P18C	für Fräaserschaft for milling shank
Z18.0510.01	M22	1.0-1.75	5.85	5.0	17.7	0.12	1.03	3	●	ZH18...
Z18.0720.01	M22	1.0-2.0	5.85	4.7	17.7	0.12	1.19	3	●	
Z18.0815.01	M22	1.5-2.75	5.85	4.6	17.7	0.19	1.62	3	●	
Z18.1020.01	M24	2.0-3.75	5.85	4.2	17.7	0.25	2.22	3	●	
Z18.1325.01	M24	2.0-3.0	5.85	4.4	17.7	0.25	1.73	3	●	
Z18.1630.01	M24	2.5-5.0	5.85	3.8	17.7	0.31	2.98	3	●	
Z18.1835.01	M24	3.0-5.5	5.85	3.6	17.7	0.38	3.25	3	●	
Z18.2535.01	M24	2.0-3.5	5.85	4.2	17.7	0.25	2.06	3	●	

Weitere HM Sorten können Sie in der Sortenübersicht im Kapitel "Technische Hinweise" und der Preisliste finden.

Bestellbeispiel:  
für Sorte AL41F:  
Z18.0510.01/AL41F

More carbide grades you can find in the grades summary in the chapter "technical instructions" and in the price list.

order example:  
grade AL41F:  
Z18.0510.01/AL41F



# MINIMILL

Nut- und Formzirkularfräsen

groove milling by circular interpolation

# Typ Z618

metrisches ISO-Gewinde, Teilprofil, innen

metric ISO-thread, partial profile, internal

ab Gewindegröße M22 x 1.0

starting at thread size M22 x 1.0

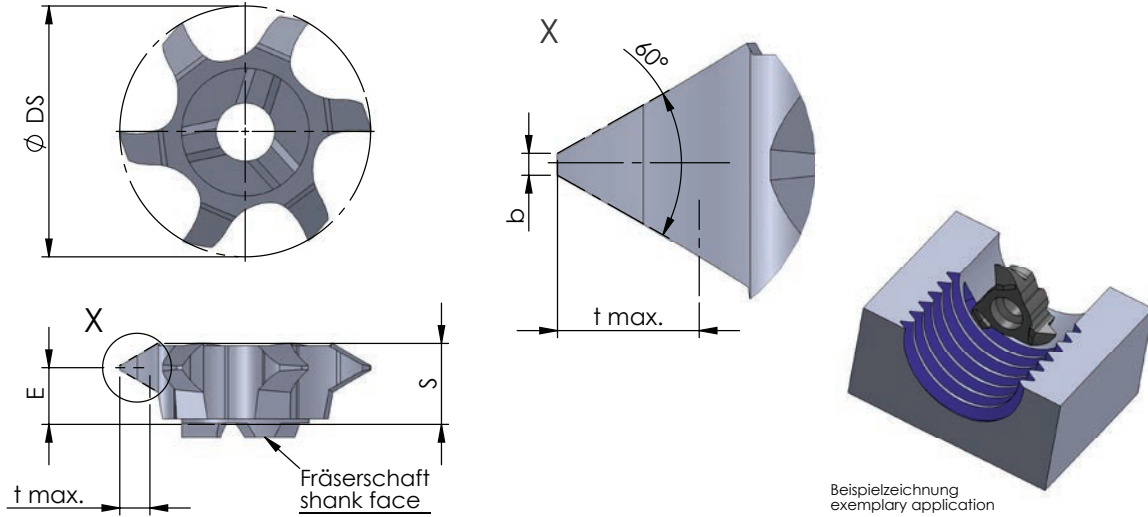

Abmessungen in mm

dimensions in mm

Bestellnummer part number	min. Gewindegröße min. thread size	Steigung P pitch P	S	E	$\varnothing DS$	b	t max.	Zähnezahl number of teeth	K10F AL41F P18C	für Fräaserschaft for milling shank
Z618.0720.01	M22	1.0-2.0	5.85	4.6	17.7	0.12	1.19	6	●	ZH18...
Z618.2545.01	M24	2.0-3.5	5.85	4.0	17.7	0.25	2.57	6	●	

Weitere HM Sorten können Sie in der Sortenübersicht im Kapitel "Technische Hinweise" und der Preisliste finden.

Bestellbeispiel:  
für Sorte AL41F:  
Z618.0720.01/AL41F

More carbide grades you can find in the grades summary in the chapter "technical instructions" and in the price list.

order example:  
grade AL41F:  
Z618.0720.01/AL41F

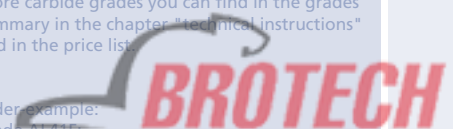

**MINIMILL**

Nut- und Formzirkularfräsen

groove milling by circular interpolation

**Typ Z18**

metrisches ISO-Gewinde, Vollprofil, innen

metric ISO-thread, full profile, internal

ab Gewindegröße M22 x 1,5

starting at thread size M22 x 1,5

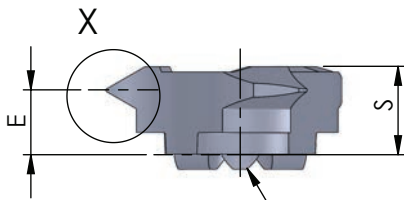
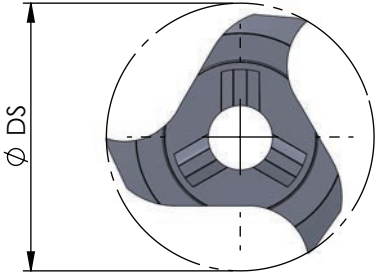

Fräseschaft  
shank face

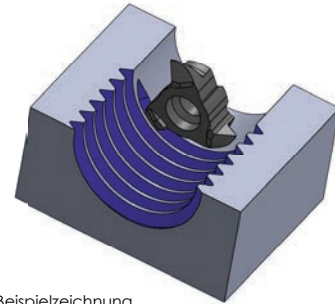
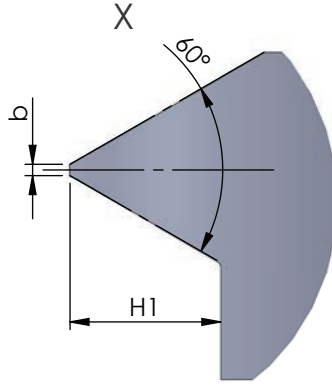

Beispielzeichnung  
exemplary application

Abmessungen in mm

dimensions in mm

Bestellnummer part number	min. Gewindegröße min. thread size	Steigung P pitch P	S	E	Ø DS	b	H1	Zähnezahl number of teeth	K10F AL41F P18C	für Fräseschaft for milling shank
Z18.0815.02	M22	1.50	5.85	4.8	17.7	0.18	0.81	3	●	ZH18...
Z18.0917.02	M22	1.75	5.85	4.7	17.7	0.20	0.95	3	●	
Z18.1020.02	M22	2.00	5.85	4.6	17.7	0.25	1.08	3	●	
Z18.1325.02	M24	2.50	5.85	4.4	17.7	0.31	1.35	3	●	
Z18.1630.02	M27	3.00	5.85	4.3	17.7	0.37	1.62	3	●	
Z18.1835.02	M27	3.50	5.85	4.0	17.7	0.43	1.895	3	●	

Weitere HM Sorten können Sie in der Sortenübersicht im Kapitel "Technische Hinweise" und der Preisliste finden.

Bestellbeispiel:  
für Sorte AL41F:  
Z18.0815.02/AL41F

More carbide grades you can find in the grades summary in the chapter "technical instructions" and in the price list.

order example:  
grade AL41F:  
Z18.0815.02/AL41F



# MINIMILL

Nut- und Formzirkularfräsen

groove milling by circular interpolation

# Typ Z618

metrisches ISO-Gewinde, Vollprofil, innen

metric ISO-thread, full profile, internal

ab Gewindegröße M22 x 1,5

starting at thread size M22 x 1,5

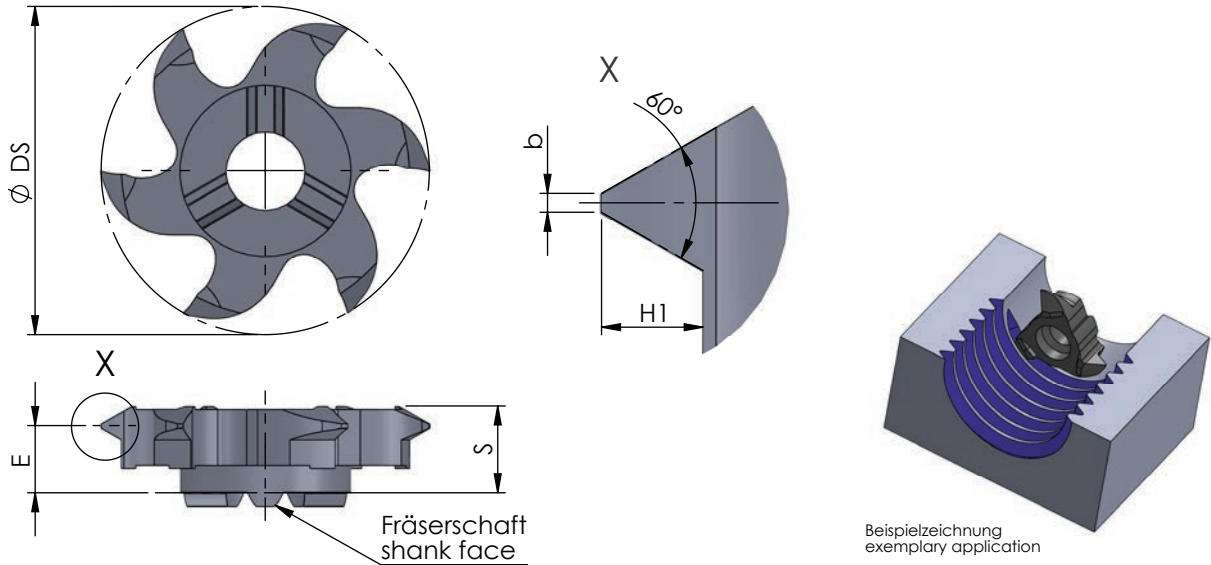

Beispielzeichnung  
exemplary application

Abmessungen in mm

dimensions in mm

Bestellnummer part number	min. Gewindegröße min. thread size	Steigung P pitch P	S	E	Ø DS	b	H1	Zähnezahl number of teeth	K10F AL41F P18C	für Fräterschaft for milling shank
neu Z618.0815.02	M22	1.50	5.85	5.0	17.7	0.19	0.81	6	●	ZH18...
neu Z618.1020.02	M22	2.00	5.85	4.8	17.7	0.25	1.083	6	●	
neu Z618.1630.02	M27	3.00	5.85	4.6	17.7	0.38	1.62	6	●	
neu Z618.1835.02	M27	3.50	5.85	4.0	17.7	0.44	1.89	6	●	

Weitere HM Sorten können Sie in der Sortenübersicht im Kapitel "Technische Hinweise" und der Preisliste finden.

Bestellbeispiel:  
für Sorte AL41F:  
Z618.0815.02/AL41F

More carbide grades you can find in the grades summary in the chapter "technical instructions" and in the price list.

order-example:  
grade AL41F:  
Z618.0815.02/AL41F





**MINIMILL**

Nut- und Formzirkularfräsen

groove milling by circular interpolation

**Typ Z22**

metrisches ISO-Gewinde, Teilprofil, innen

metric ISO-thread, partial profile, internal

ab Gewindegröße M27 x 1,0

starting at thread size M27 x 1,0

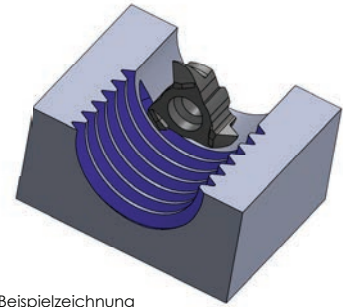
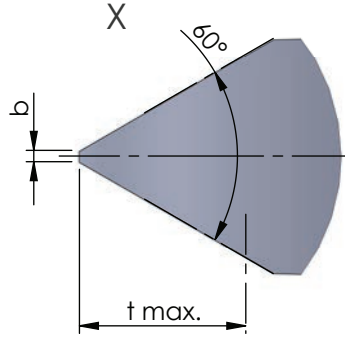
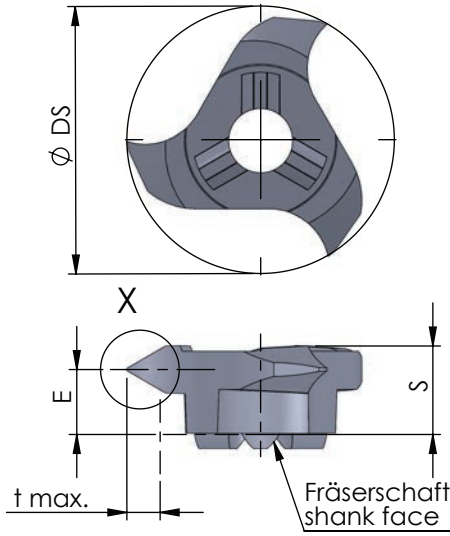

Beispielzeichnung  
exemplary application

Abmessungen in mm

dimensions in mm

Bestellnummer part number	min. Gewindegröße min. thread size	Steigung P pitch P	S	E	Ø DS	b	t max.	Zähnezahl number of teeth	K10F AL41F P18C	für Fräaserschaft for milling shank
Z22.0720.01	M27	1.0-2.0	5.85	4.6	21.7	0.12	1.19	3	●	ZH22...
Z22.0815.01	M27	1.5-2.75	5.85	4.5	21.7	0.18	1.62	3	●	
Z22.1020.01	M27	2.0-3.75	5.85	4.2	21.7	0.25	2.22	3	●	
Z22.1630.01	M30	2.5-5.0	5.85	3.8	21.7	0.31	2.98	3	●	
Z22.2140.01	M30	3.5-6.0	5.85	3.4	21.7	0.44	3.52	3	●	
Z22.2445.01	M30	3.5-6.5	5.85	3.2	21.7	0.44	3.84	3	●	
Z22.2545.01	M27	2.5-4.5	5.85	3.7	21.7	0.31	2.70	3	●	

Weitere HM Sorten können Sie in der Sortenübersicht im Kapitel "Technische Hinweise" und der Preisliste finden.

Bestellbeispiel:  
für Sorte AL41F:  
Z22.0720.01/AL41F

More carbide grades you can find in the grades summary in the chapter "technical instructions" and in the price list.

order example:  
grade AL41F:  
Z22.0720.01/AL41F

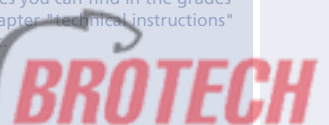

# MINIMILL

Nut- und Formzirkularfräsen

groove milling by circular interpolation

# Typ Z622

metrisches ISO-Gewinde, Teilprofil, innen

metric ISO-thread, partial profile, internal

ab Gewindegröße M27 x 1,0

starting at thread size M27 x 1,0

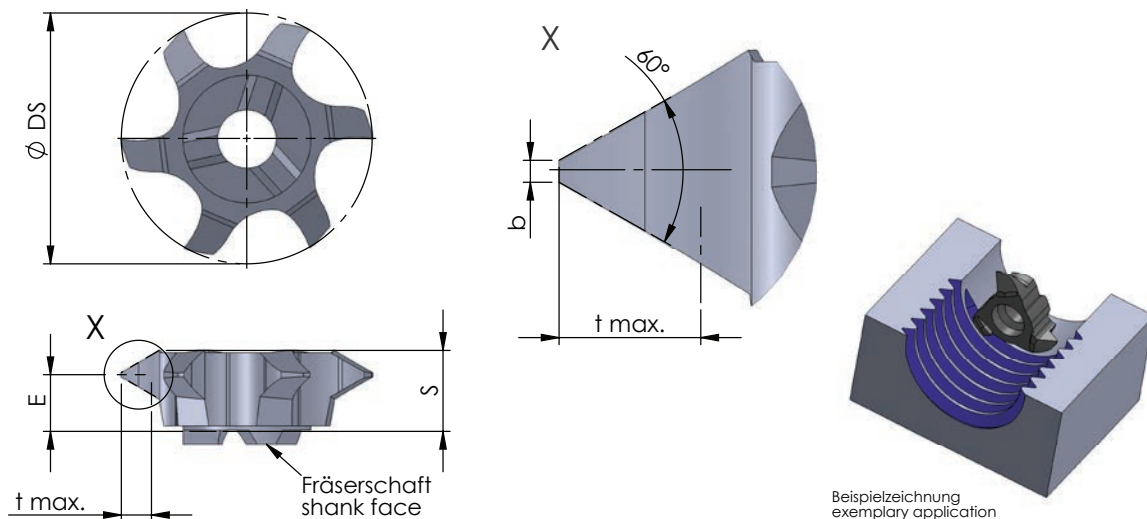

Abmessungen in mm

dimensions in mm

Bestellnummer part number	min. Gewindegröße min. thread size	Steigung P pitch P	S	E	Ø DS	b	t max.	Zähnezahl number of teeth	K10F AL41F P18C	für Fräterschaft for milling shank
Z622.0720.01	M27	1.0-2.0	6.2	5.0	21.7	0.12	1.19	6	●	ZH22...
Z622.2545.01	M27	2.0-4.5	6.05	4.2	21.7	0.25	2.7	6	●	

Weitere HM Sorten können Sie in der Sortenübersicht im Kapitel "Technische Hinweise" und der Preisliste finden.

Bestellbeispiel:  
für Sorte AL41F:  
Z622.0720.01/AL41F

More carbide grades you can find in the grades summary in the chapter "technical instructions" and in the price list.

order example:  
grade AL41F:  
Z622.0720.01/AL41F

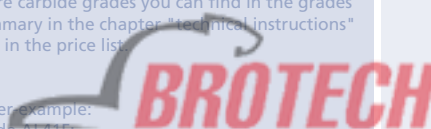

**MINIMILL**

Nut- und Formzirkularfräsen

groove milling by circular interpolation

**Typ Z22**

metrisches ISO-Gewinde, Vollprofil, innen

metric ISO-thread, full profile, internal

ab Gewindegröße M24 x 1,5

starting at thread size M24 x 1,5

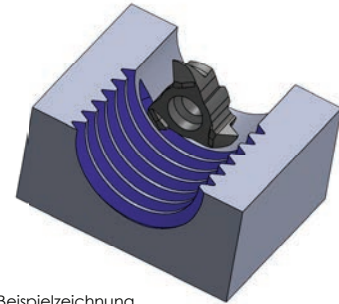
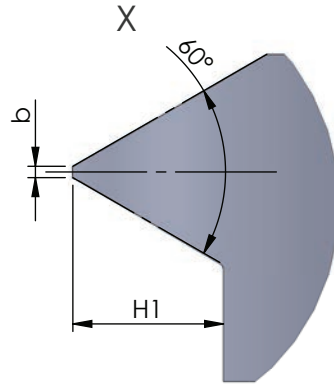
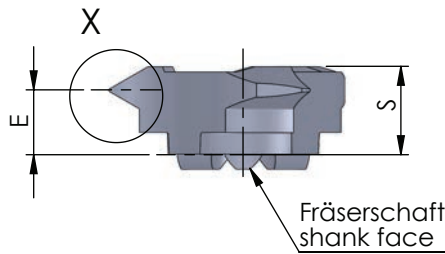
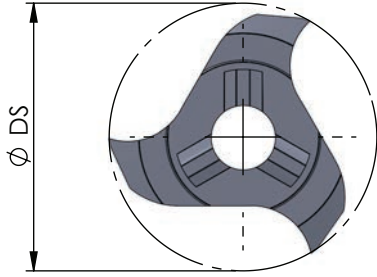

Beispielzeichnung  
exemplary application

Abmessungen in mm

dimensions in mm

Bestellnummer part number	min. Gewindegröße min. thread size	Steigung P pitch P	S	E	Ø DS	b	H1	Zähnezahl number of teeth	K10F AL41F P18C	für Fräuserschaft for milling shank
Z22.0815.02	M24	1.50	5.85	4.8	21.7	0.19	0.81	3	●	ZH22...
Z22.0917.02	M27	1.75	5.85	4.7	21.7	0.22	0.95	3	●	
Z22.1020.02	M27	2.00	5.85	4.6	21.7	0.25	1.08	3	●	
Z22.1630.02	M30	3.00	5.85	4.3	21.7	0.37	1.62	3	●	
Z22.1835.02	M30	3.50	5.85	4.0	21.7	0.43	1.89	3	●	
Z22.2140.02	M33	4.00	5.85	3.9	21.7	0.50	2.16	3	●	
Z22.2445.02	M33	4.50	5.85	3.7	21.7	0.56	2.43	3	●	

Weitere HM Sorten können Sie in der Sortenübersicht im Kapitel "Technische Hinweise" und der Preisliste finden.

Bestellbeispiel:  
für Sorte AL41F:  
Z22.0815.02/AL41F

More carbide grades you can find in the grades summary in the chapter "technical instructions" and in the price list.

order example:  
grade AL41F:  
Z22.0815.02/AL41F

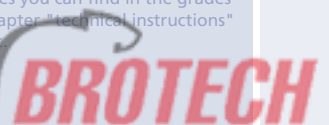

# MINIMILL

Nut- und Formzirkularfräsen

groove milling by circular interpolation

# Typ Z622

metrisches ISO-Gewinde, Vollprofil, innen

metric ISO-thread, full profile, internal

ab Gewindegröße M24 x 1,5

starting at thread size M24 x 1,5

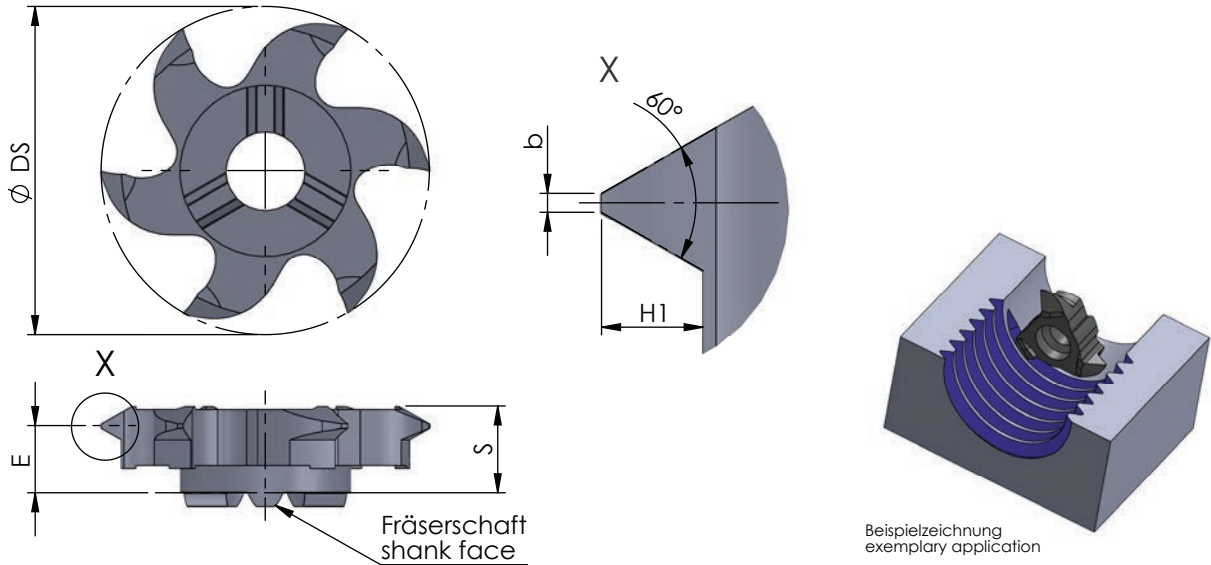

Beispielzeichnung  
exemplary application

Abmessungen in mm

dimensions in mm

Bestellnummer part number	min. Gewindegröße min. thread size	Steigung P pitch P	S	E	Ø DS	b	H1	Zähnezahl number of teeth	K10F AL41F P18C	für Frärschaft for milling shank
Z622.0815.02	M24	1.50	6.2	5.3	21.7	0.19	0.81	6	●	ZH22...
Z622.0917.02	M27	1.75	6.2	5.2	21.7	0.22	0.95	6	●	
Z622.1020.02	M27	2.00	6.2	5.0	21.7	0.25	1.08	6	●	
Z622.1630.02	M30	3.00	6.2	4.8	21.7	0.37	1.62	6	●	
Z622.2140.02	M33	4.00	6.2	4.4	21.7	0.50	2.16	6	●	

Weitere HM Sorten können Sie in der Sortenübersicht im Kapitel "Technische Hinweise" und der Preisliste finden.

Bestellbeispiel:  
für Sorte AL41F:  
Z622.0815.02/AL41F

More carbide grades you can find in the grades summary in the chapter "technical instructions" and in the price list.

order example:  
grade AL41F:  
Z622.0815.02/AL41F

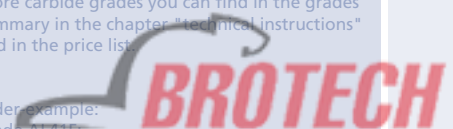

**MINIMILL**

Nut- und Formzirkularfräsen

groove milling by circular interpolation

**Typ Z28**

metrisches ISO-Gewinde, Teilprofil, innen

metric ISO-thread, partial profile, internal

ab Gewindegröße M33 x 1,0

starting at thread size M33 x 1,0

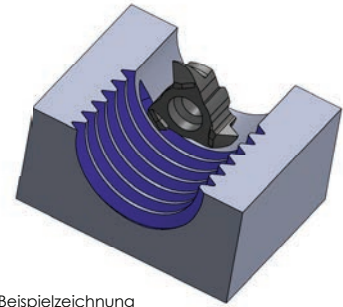
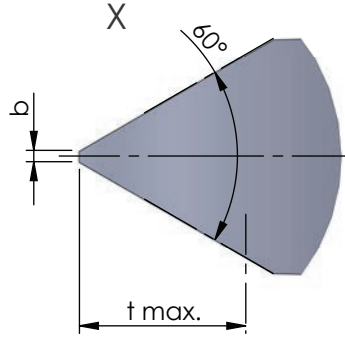
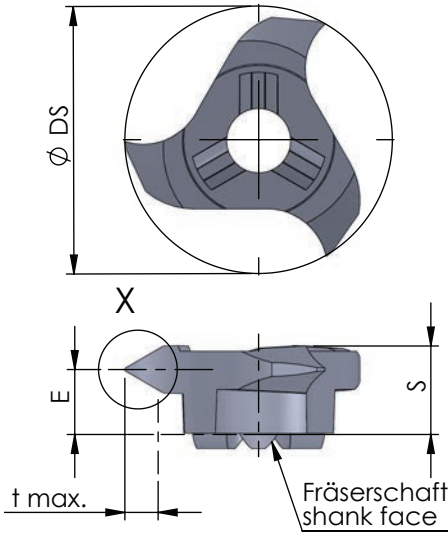

Beispielzeichnung  
exemplary application

Abmessungen in mm

dimensions in mm

Bestellnummer part number	min. Gewindegröße min. thread size	Steigung P pitch P	S	E	Ø DS	b	t max.	Zähnezahl number of teeth	K10F AL41F P18C	für Fräaserschaft for milling shank
Z28.0720.01	M33	1.0-2.0	6.6	4.6	27.7	0.12	1.20	3	●	ZH28...
Z28.1525.01	M33	1.5-2.5	6.6	4.3	27.7	0.18	1.49	3	●	
Z28.3050.01	M36	2.5-5.0	6.6	4.0	27.7	0.37	2.93	3	●	
Z28.5060.01	M39	4.0-6.0	6.6	3.6	27.7	0.50	4.60	3	●	

Weitere HM Sorten können Sie in der Sortenübersicht im Kapitel "Technische Hinweise" und der Preisliste finden.

Bestellbeispiel:  
für Sorte AL41F:  
Z28.0720.01/AL41F

More carbide grades you can find in the grades summary in the chapter "technical instructions" and in the price list.

order example:  
grade AL41F:  
Z28.0720.01/AL41F



# MINIMILL

Nut- und Formzirkularfräsen

groove milling by circular interpolation

# Typ Z628

metrisches ISO-Gewinde, Teilprofil, innen

metric ISO-thread, partial profile, internal

ab Gewindegröße M33 x 1,5

starting at thread size M33 x 1,5

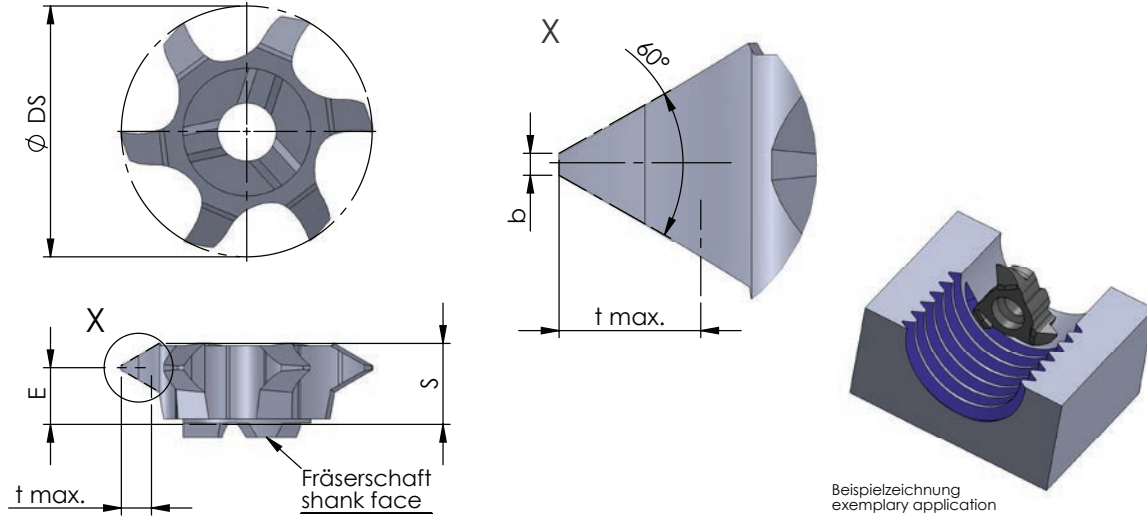

Abmessungen in mm

dimensions in mm

Bestellnummer part number	min. Gewindegröße min. thread size	Steigung P pitch P	S	E	Ø DS	b	t max.	Zähnezahl number of teeth	K10F AL41F P18C	für Fräterschaft for milling shank
Z628.1525.01	M33	1.5-2.5	6.5	5.0	27.7	0.19	1.6	6	●	ZH28....
Z628.3050.01	M36	2.5-5.0	6.1	3.9	27.7	0.38	2.93	6	●	

Weitere HM Sorten können Sie in der Sortenübersicht im Kapitel "Technische Hinweise" und der Preisliste finden.

Bestellbeispiel:  
für Sorte AL41F:  
Z628.1525.01/AL41F

More carbide grades you can find in the grades summary in the chapter "technical instructions" and in the price list.

order example:  
grade AL41F:  
Z628.1525.01/AL41F

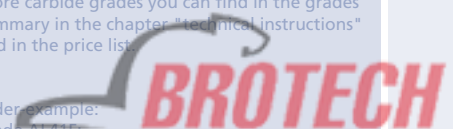

**MINIMILL**

Nut- und Formzirkularfräsen

groove milling by circular interpolation

**Typ Z622**

metrisches ISO-Gewinde, Vollprofil, außen

metric ISO-thread, full profile, external

Steigung 1.5 - 4.0

pitch 1.5 - 4.0

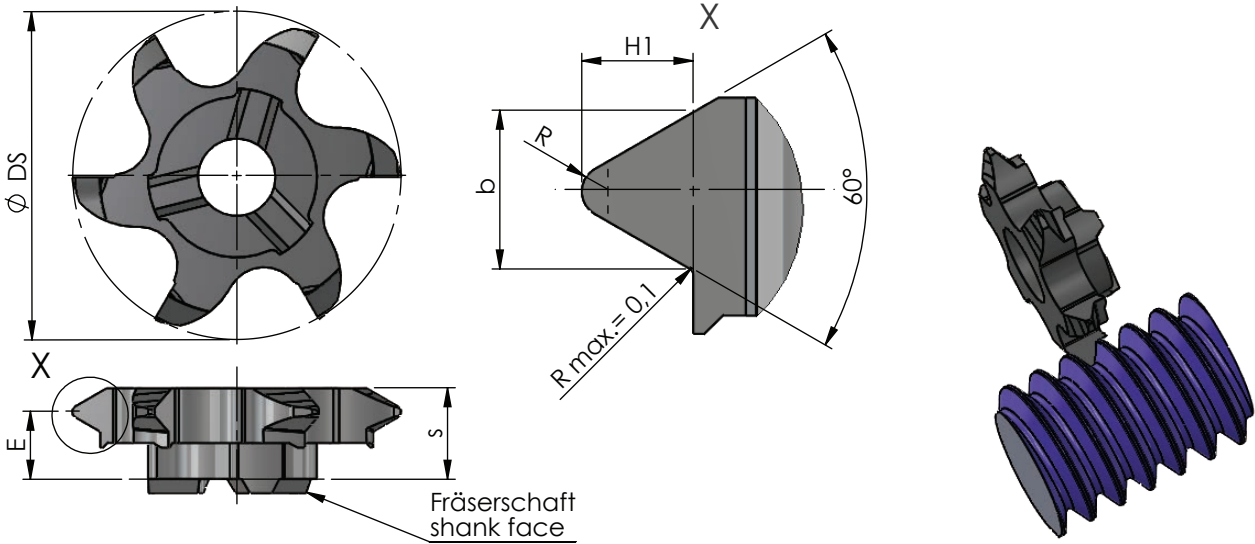

Abmessungen in mm

dimensions in mm

Bestellnummer part number	Steigung P pitch P	S	E	R	$\varnothing DS$	$b \pm 0.01$	H1	Zähnezahl number of teeth	K10F AL41F P18C	für Fräaserschaft for milling shank
Z622.E0815.02	1.50	6.25	5.35	0.22	21.7	1.316	0.92	6	●	ZH22...
Z622.E0917.02	1.75	6.25	5.25	0.25	21.7	1.524	1.07	6	●	
Z622.E1020.02	2.00	6.25	5.10	0.29	21.7	1.755	1.23	6	●	
Z622.E1630.02	3.00	6.05	4.50	0.43	21.7	2.621	1.84	6	●	
Z622.E2140.02	4.00	6.05	4.00	0.58	21.7	3.499	2.45	6	●	

Weitere HM Sorten können Sie in der Sortenübersicht im Kapitel "Technische Hinweise" und der Preisliste finden.

Bestellbeispiel:  
für Sorte AL41F:  
Z622.E0815.02/AL41F

More carbide grades you can find in the grades summary in the chapter "technical instructions" and in the price list.

order example:  
grade AL41F:  
Z622.E0815.02/AL41F



# MINIMILL

Nut- und Formzirkularfräsen

groove milling by circular interpolation

# Typ Z12

Whitworth-Gewinde, Vollprofil, innen

Whitworth thread, full profile, internal

ab Gewindegröße G 3/8"

starting at thread size G 3/8"

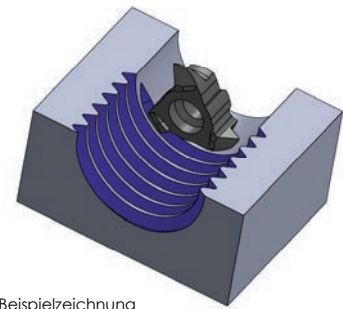
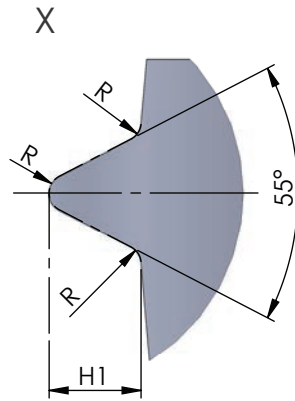
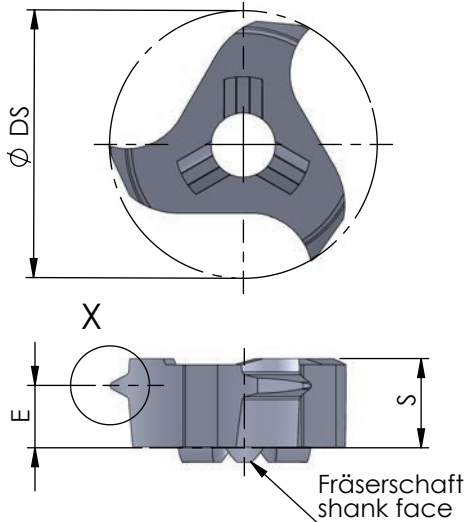

Beispielzeichnung  
exemplary application

Abmessungen in mm

dimensions in mm

Bestellnummer part number	min. Gewindegröße min. thread size	Gang / Zoll threads / inch	S	E	Ø DS	H1	R	Zähnezahl number of teeth	Material			für Frärschaft for milling shank
									K10F	AL41F	P18C	
Z12.0813.19	G 3/8"	19	3.6	2.5	11.7	0.86	0.18	3	●			
Z12.1118.14	G 1/2"	14	3.6	2.3	11.7	1.16	0.24	3	●			ZH10...
Z12.1423.11	G 1"	11	3.6	2.0	11.7	1.48	0.31	3	●			

Weitere HM Sorten können Sie in der Sortenübersicht im Kapitel "Technische Hinweise" und der Preisliste finden.

Bestellbeispiel:  
für Sorte AL41F:  
Z12.1423.11/AL41F

More carbide grades you can find in the grades summary in the chapter "technical instructions" and in the price list.

order example:  
grade AL41F:  
Z12.1423.11/AL41F





**MINIMILL**

Nut- und Formzirkularfräsen

groove milling by circular interpolation

**Typ Z614**

Whitworth-Gewinde,  
Vollprofil, innen

Whitworth thread,  
full profile, internal

ab Gewindegröße G 3/4"

starting at thread size G 3/4"

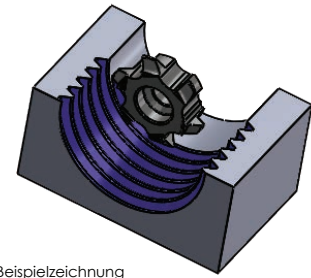
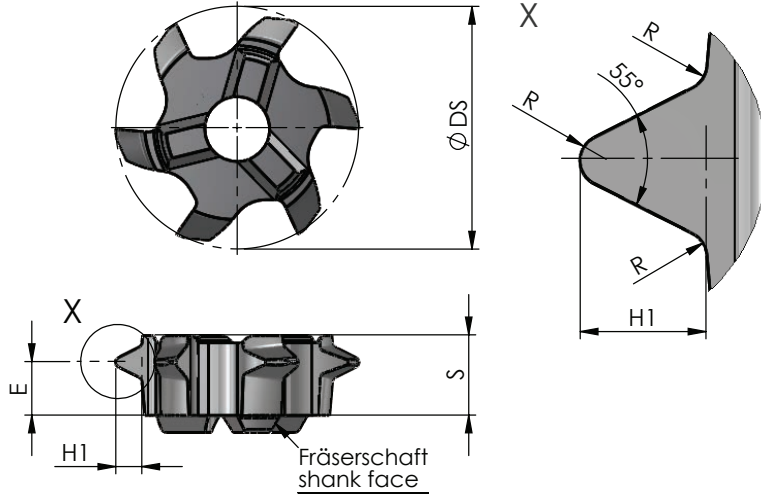

Beispielzeichnung  
exemplary application

Abmessungen in mm

dimensions in mm

Bestellnummer part number	min. Gewindegröße min. thread size	Gang / Zoll threads / inch	S	E	$\varnothing DS$	H1	R	Zähnezahl number of teeth				für Fräterschaft for milling shank
									K10F	AL41F	P18C	
Z614.5514.02	G 3/4"	14	4.6	3.3	13.7	1.16	0.24	6	●			
Z614.5511.02	G 1"	11	4.6	3.1	13.7	1.48	0.31	6	●			ZH14...

Weitere HM Sorten können Sie in der Sortenübersicht im Kapitel "Technische Hinweise" und der Preisliste finden.

Bestellbeispiel:  
für Sorte AL41F:  
Z614.5514.02/AL41F

More carbide grades you can find in the grades summary in the chapter "technical instructions" and in the price list.

order example:  
grade AL41F:  
Z614.5514.02/AL41F

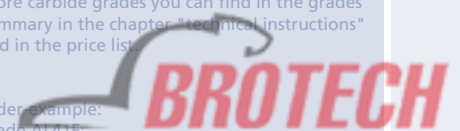

# MINIMILL

Nut- und Formzirkularfräsen

groove milling by circular interpolation

# Typ Z16

Whitworth-Gewinde, Vollprofil, innen

Whitworth thread, full profile, internal

ab Gewindegröße G 5/8"

starting at thread size G 5/8"

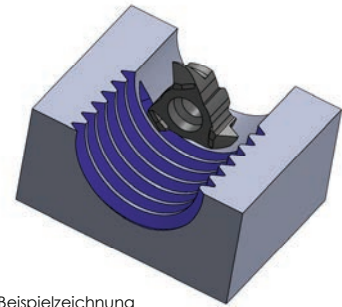
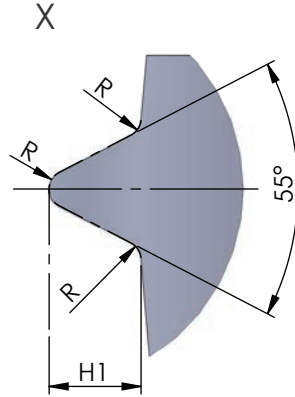
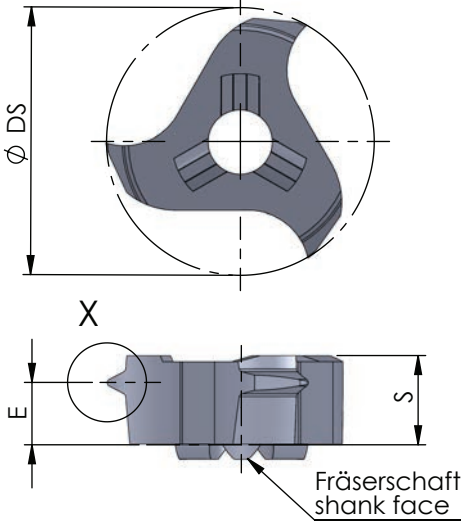

Beispielzeichnung  
exemplary application

Abmessungen in mm

dimensions in mm

neu  
neu

Bestellnummer part number	min. Gewindegröße min. thread size	Gang / Zoll threads / inch	S	E	Ø DS	H1	R	Zähnezahl number of teeth	K10F AL41F P18C	für Frälerschaft for milling shank
Z16.5514.02	G 5/8"	14	4.5	3.0	15.7	1.17	0.24	3	●	
Z16.5511.02	G 1"	11	4.5	2.8	15.7	1.48	0.31	3	●	ZH14...

Weitere HM Sorten können Sie in der Sortenübersicht im Kapitel "Technische Hinweise" und der Preisliste finden.

Bestellbeispiel:  
für Sorte AL41F:  
Z16.5514.02/AL41F

More carbide grades you can find in the grades summary in the chapter "technical instructions" and in the price list.

order-example:  
grade AL41F:  
Z16.5514.02/AL41F



**MINIMILL**

Nut- und Formzirkularfräsen

groove milling by circular interpolation

**Typ Z18**

Whitworth-Gewinde,  
Vollprofil, innen

Whitworth thread,  
full profile, internal

ab Gewindegröße G 3/4"

starting at thread size G 3/4"

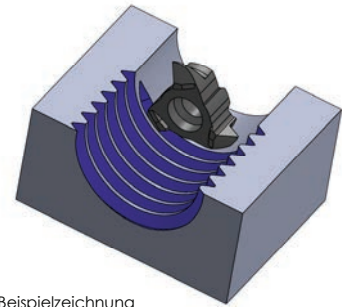
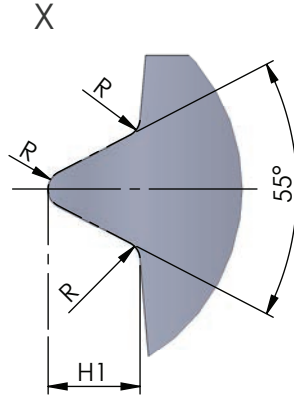
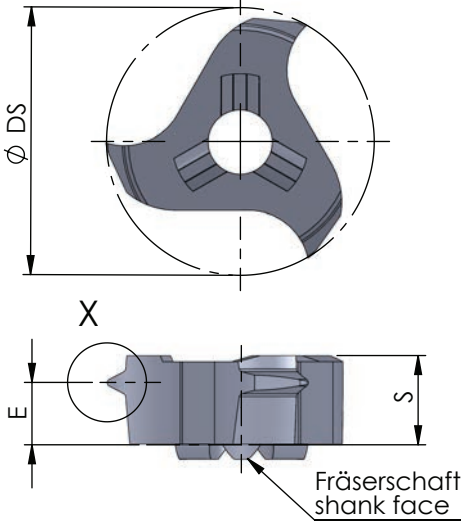

Beispielzeichnung  
exemplary application

Abmessungen in mm

dimensions in mm

Bestellnummer part number	min. Gewindegröße min. thread size	Gang / Zoll threads / inch	S	E	Ø DS	H1	R	Zähnezahl number of teeth	Material			für Frärschaft for milling shank
									K10F	AL41F	P18C	
Z18.5511.02	G 1"	11	5.85	4.4	17.7	1.48	0.32	3	●			
Z18.5514.02	G ¾"	14	5.85	4.6	17.7	1.16	0.25	3	●			ZH18...
Z18.5519.02	-	19	5.85	4.9	17.7	0.857	0.18	3	●			

Weitere HM Sorten können Sie in der Sortenübersicht im Kapitel "Technische Hinweise" und der Preisliste finden.

Bestellbeispiel:  
für Sorte AL41F:  
Z18.5519.02/AL41F

More carbide grades you can find in the grades summary in the chapter "technical instructions" and in the price list.

order example:  
grade AL41F:  
Z18.5519.02/AL41F



# MINIMILL

Nut- und Formzirkularfräsen

groove milling by circular interpolation

# Typ Z22

Whitworth-Gewinde, Vollprofil, innen

Whitworth thread, full profile, internal

ab Gewindegröße G 1"

starting at thread size G 1"

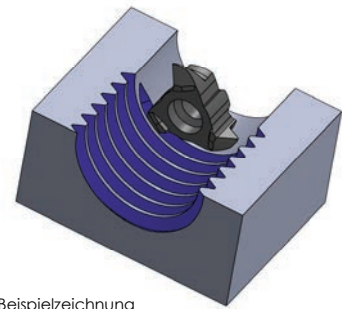
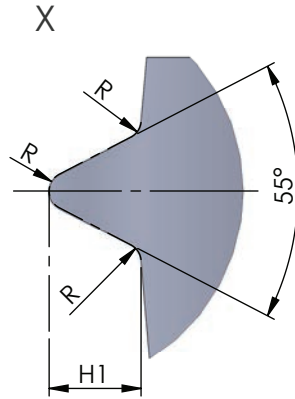
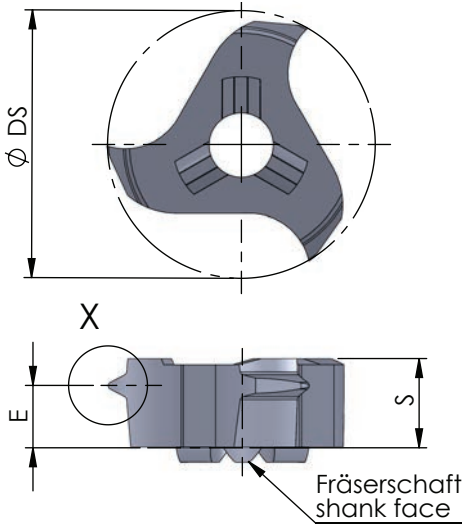

Beispielzeichnung  
exemplary application

Abmessungen in mm

dimensions in mm

Bestellnummer part number	min. Gewindegröße min. thread size	Gang / Zoll threads / inch	S	E	Ø DS	H1	R	Zähnezahl number of teeth	Material			für Frärschaft for milling shank
									K10F	AL41F	P18C	
Z22.5506.02	BSW 1½"	6	5.85	3.1	21.7	2.71	0.58	3	●			
Z22.5508.02	-	8	5.85	3.5	21.7	2.03	0.43	3	●			ZH22...
Z22.5511.02	G 1"	11	5.85	4.0	21.7	1.48	0.31	3	●			

Weitere HM Sorten können Sie in der Sortenübersicht im Kapitel "Technische Hinweise" und der Preisliste finden.

Bestellbeispiel:  
für Sorte AL41F:  
Z22.5508.02/AL41F

More carbide grades you can find in the grades summary in the chapter "technical instructions" and in the price list.

order example:  
grade AL41F:  
Z22.5508.02/AL41F



**MINIMILL**

Nut- und Formzirkularfräsen

groove milling by circular interpolation

**Typ Z622**

Whitworth-Gewinde, Vollprofil, innen

Whitworth thread, full profile, internal

ab Gewindegröße G 1"

starting at thread size G 1"

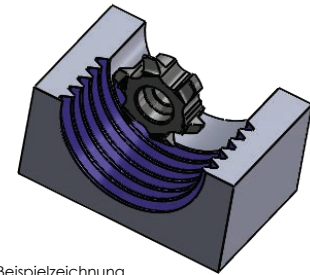
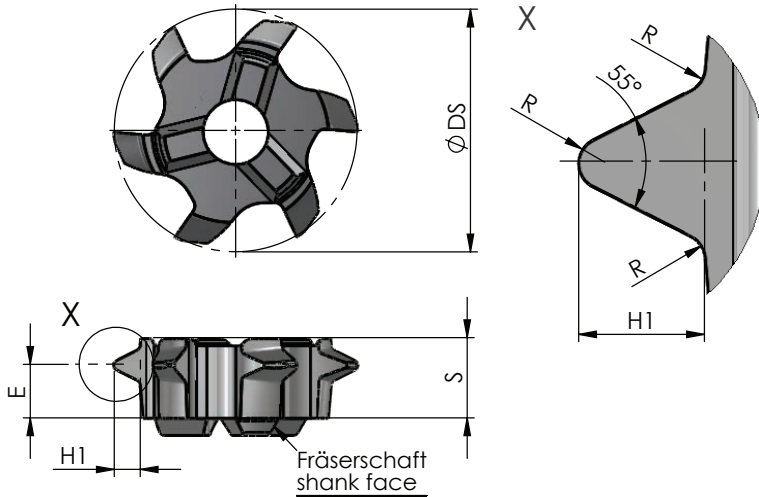

Beispielzeichnung  
exemplary application

Abmessungen in mm

dimensions in mm

Bestellnummer part number	min. Gewindegröße min. thread size	Gang / Zoll threads / inch	S	E	$\varnothing DS$	H1	R	Zähnezahl number of teeth	K10F	AL41F	P18C	für Frälerschaft for milling shank
Z622.5506.02	BSW 1½"	6	6.05	3.8	21.7	2.71	0.58	6	●			
Z622.5508.02	-	8	6.31	4.2	21.7	2.03	0.43	6	●			ZH22...
Z622.5511.02	G 1"	11	6.35	4.8	21.7	1.48	0.31	6	●			

Weitere HM Sorten können Sie in der Sortenübersicht im Kapitel "Technische Hinweise" und der Preisliste finden.

Bestellbeispiel:  
für Sorte AL41F:  
Z622.5506.02/AL41F

More carbide grades you can find in the grades summary in the chapter "technical instructions" and in the price list.

order example:  
grade AL41F:  
Z622.5506.02/AL41F

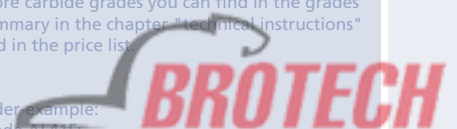

# MINIMILL

Nut- und Formzirkularfräsen

groove milling by circular interpolation

# Typ Z10 / Z12

Vorwärts- und Rückwärtsfasen

forward & backward chamfering

D min. 10 / 12 mm

D min. 10 / 12 mm

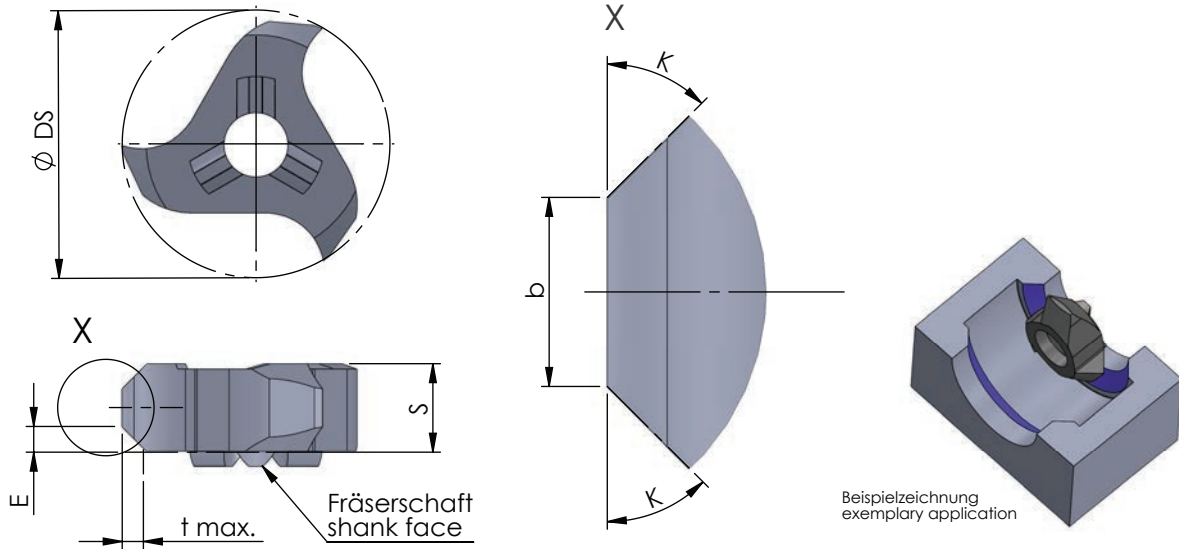

Abmessungen in mm

dimensions in mm

Bestellnummer part number	K	D min.	S	E	$\varnothing DS$	b	t max.	Zähnezahl number of teeth	Material			für Fräseschaft for milling shank
									K10F	AL41F	P18C	
Z10.4545.35	45°	10	3.5	1.4	9.7	0.9	1.0	3	●			
Z12.4545.35	45°	12	3.5	1.2	11.7	1.2	0.8	3	●			ZH10...

Weitere HM Sorten können Sie in der Sortenübersicht im Kapitel "Technische Hinweise" und der Preisliste finden.

Bestellbeispiel:  
für Sorte AL41F:  
Z12.4545.35/AL41F

More carbide grades you can find in the grades summary in the chapter "technical instructions" and in the price list.

order example:  
grade AL41F:  
Z12.4545.35/AL41F

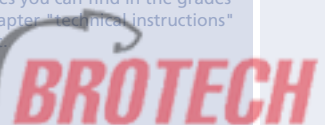

**MINIMILL**

Nut- und Formzirkularfräsen

groove milling by circular interpolation

**Typ Z610**

Vorwärts- und Rückwärtsfasen

forward & backward chamfering

D min. 10 mm

D min. 10 mm

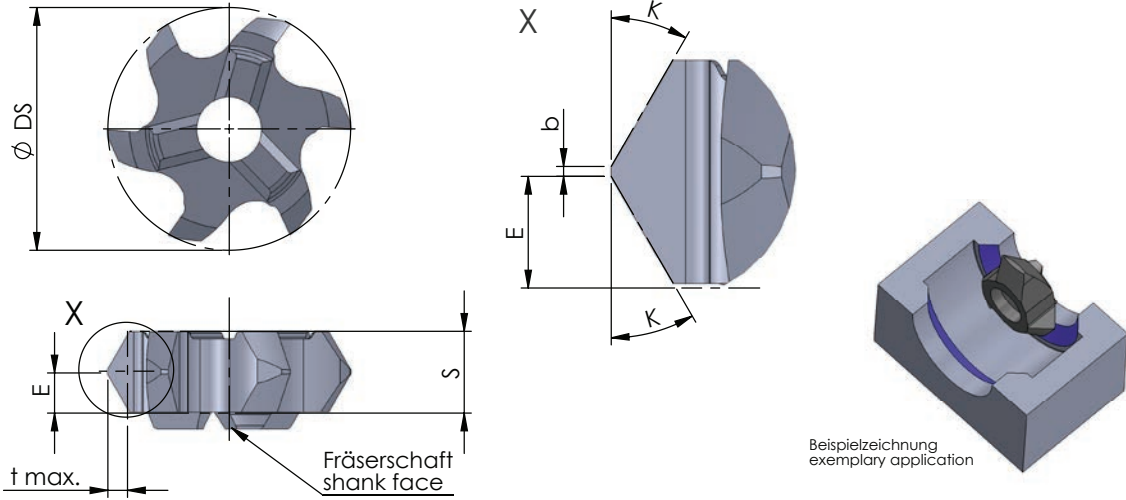

Abmessungen in mm

dimensions in mm

Bestellnummer part number	K	D min.	S	E	$\varnothing DS$	b	t max.	Zähnezahl number of teeth	Material			für Fräseschaft for milling shank
									K10F	AL41F	P18C	
Z610.1515.02	15°	10	3.6	1.8	9.7	0.2	0.35	6	●			ZH10...
Z610.2020.02	20°	10	3.6	1.8	9.7	0.2	0.45	6	●			
Z610.3030.02	30°	10	3.6	1.8	9.7	0.2	0.7	6	●			
Z610.4545.02	45°	10	3.6	1.8	9.7	0.2	1.2	6	●			

Weitere HM Sorten können Sie in der Sortenübersicht im Kapitel "Technische Hinweise" und der Preisliste finden.

Bestellbeispiel:  
für Sorte AL41F:  
Z610.1515.02/AL41F

More carbide grades you can find in the grades summary in the chapter "technical instructions" and in the price list.

order example:  
grade AL41F:  
Z610.1515.02/AL41F



# MINIMILL

Nut- und Formzirkularfräsen

groove milling by circular interpolation

# Typ Z614

Vorwärts- und Rückwärtsfasen

forward & backward chamfering

D min. 14 mm

D min. 14 mm

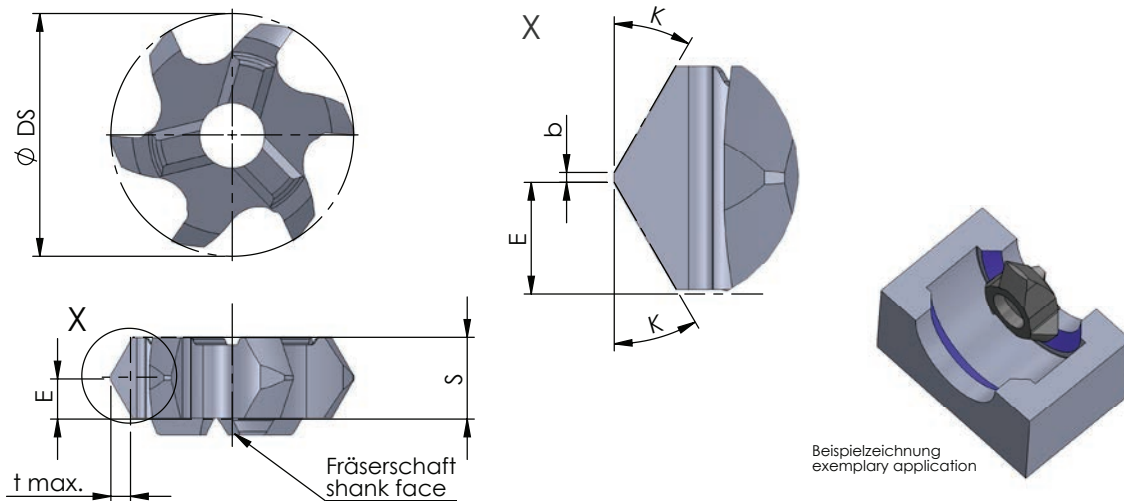

Abmessungen in mm

dimensions in mm

Bestellnummer part number	K	D min.	S	E	$\varnothing DS$	b	t max.	Zähnezahl number of teeth	Material			für Fräterschaft for milling shank
									K10F	AL41F	P18C	
Z614.1515.02	15°	14	4.6	2.3	13.7	0.2	0.35	6	●			
Z614.2020.02	20°	14	4.6	2.3	13.7	0.2	0.45	6	●			
Z614.3030.02	30°	14	4.6	2.3	13.7	0.2	0.7	6	●			
Z614.4545.02	45°	14	4.6	2.3	13.7	0.2	1.8	6	●			ZH14...

Weitere HM Sorten können Sie in der Sortenübersicht im Kapitel "Technische Hinweise" und der Preisliste finden.

Bestellbeispiel:  
für Sorte AL41F:  
Z614.1515.02/AL41F

More carbide grades you can find in the grades summary in the chapter "technical instructions" and in the price list.

order example:  
grade AL41F:  
Z614.1515.02/AL41F

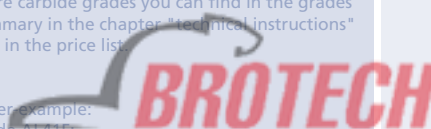



**MINIMILL**

Nut- und Formzirkularfräsen

groove milling by circular interpolation

**Typ Z16**

Vorwärts- und Rückwärtsfasen

forward & backward chamfering

D min. 16 mm

D min. 16 mm

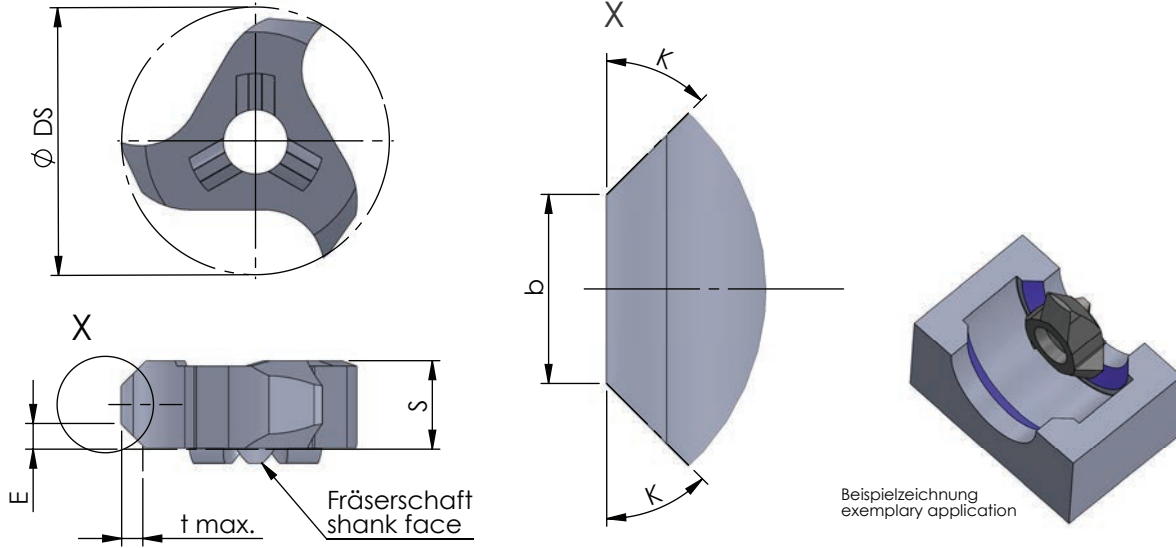

Abmessungen in mm

dimensions in mm

Bestellnummer part number	K	D min.	S	E	$\varnothing DS$	b	t max.	Zähnezahl number of teeth	Material			für Frälerschaft for milling shank
									K10F	AL41F	P18C	
Z16.4545.35	45°	16	4.5	1.6	15.7	1.4	1.4	3	●			
Z16.4545.02	45°	16	4.5	2.2	15.7	0.2	1.8	3	●			ZH14...

Weitere HM Sorten können Sie in der Sortenübersicht im Kapitel "Technische Hinweise" und der Preisliste finden.

Bestellbeispiel:  
für Sorte AL41F:  
Z16.4545.35/AL41F

More carbide grades you can find in the grades summary in the chapter "technical instructions" and in the price list.

order example:  
grade AL41F:  
Z16.4545.35/AL41F

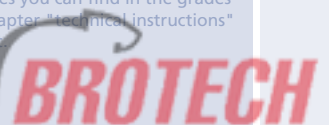

# MINIMILL

Nut- und Formzirkularfräsen

groove milling by circular interpolation

# Typ Z18

Vorwärts- und Rückwärtsfasen

forward & backward chamfering

D min. 15 mm

D min. 15 mm

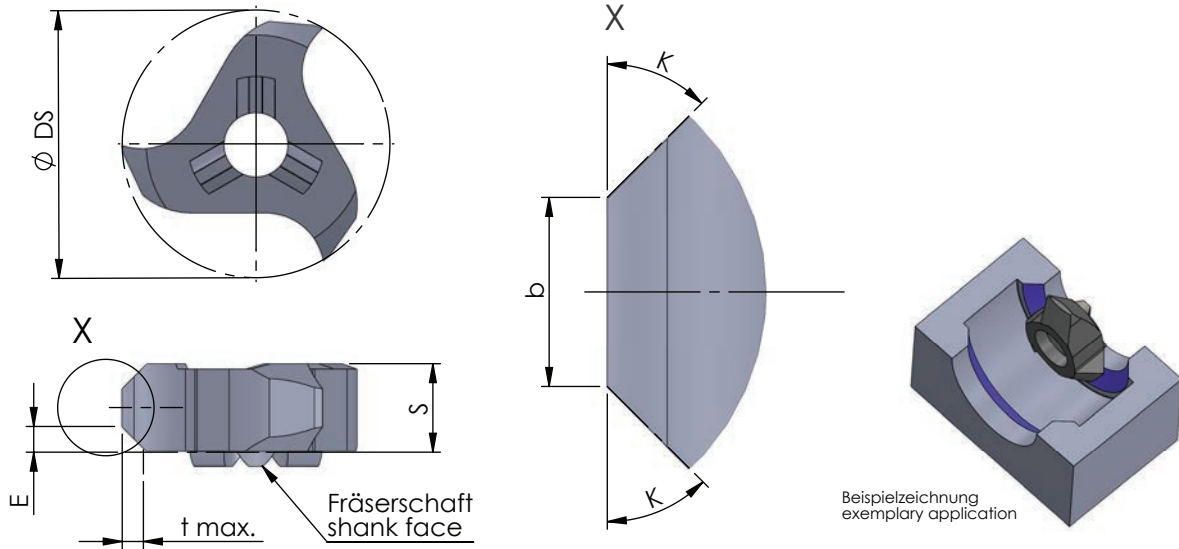

Abmessungen in mm

dimensions in mm

Bestellnummer part number	K	D min.	S	E	$\varnothing DS$	b	t max.	Zähnezahl number of teeth	Material			für Fräseschaft for milling shank
									K10F	AL41F	P18C	
Z18.4545.DS15	45°	15	5.85	2.9	14.7	0.2	2.5	3	●			
Z18.4545.58	45°	18	5.85	1.75	17.7	2.5	1.4	3	●			ZH18...

Weitere HM Sorten können Sie in der Sortenübersicht im Kapitel "Technische Hinweise" und der Preisliste finden.

Bestellbeispiel:  
für Sorte AL41F:  
Z18.4545.58/AL41F

More carbide grades you can find in the grades summary in the chapter "technical instructions" and in the price list.

order example:  
grade AL41F:  
Z18.4545.58/AL41F



**MINIMILL**

Nut- und Formzirkularfräsen

groove milling by circular interpolation

**Typ Z18**

Vorwärts- und Rückwärtsfasen mit Radius

forward & backward chamfering with radius

D min. 18 mm

D min. 18 mm

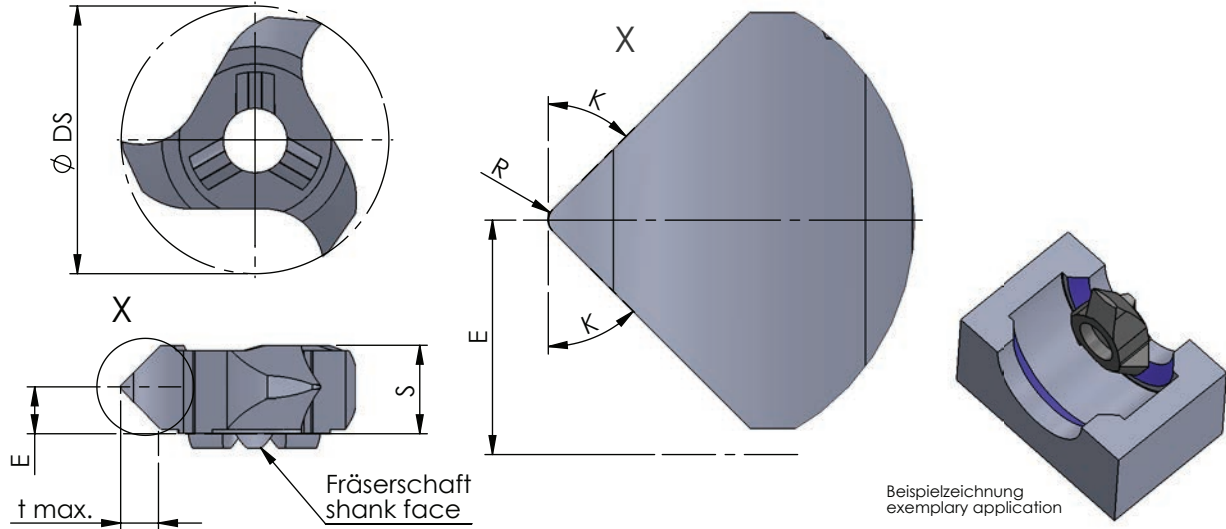

Abmessungen in mm

dimensions in mm

Bestellnummer part number	K	D min.	S	E	R	$\varnothing DS$	t max.	Zähnezahl number of teeth	K10F AL41F P18C	für Frälerschaft for milling shank
Z18.4545.02	45°	18	5.85	3.0	0.2	17.7	2.5	3	●	ZH18...

Weitere HM Sorten können Sie in der Sortenübersicht im Kapitel "Technische Hinweise" und der Preisliste finden.

Bestellbeispiel:  
für Sorte AL41F:  
Z18.4545.02/AL41F

More carbide grades you can find in the grades summary in the chapter "technical instructions" and in the price list.

order example:  
grade AL41F:  
Z18.4545.02/AL41F



# MINIMILL

Nut- und Formzirkularfräsen

groove milling by circular interpolation

# Typ Z22

Vorwärts- und Rückwärtsfasen

forward & backward chamfering

D min. 22 mm

D min. 22 mm

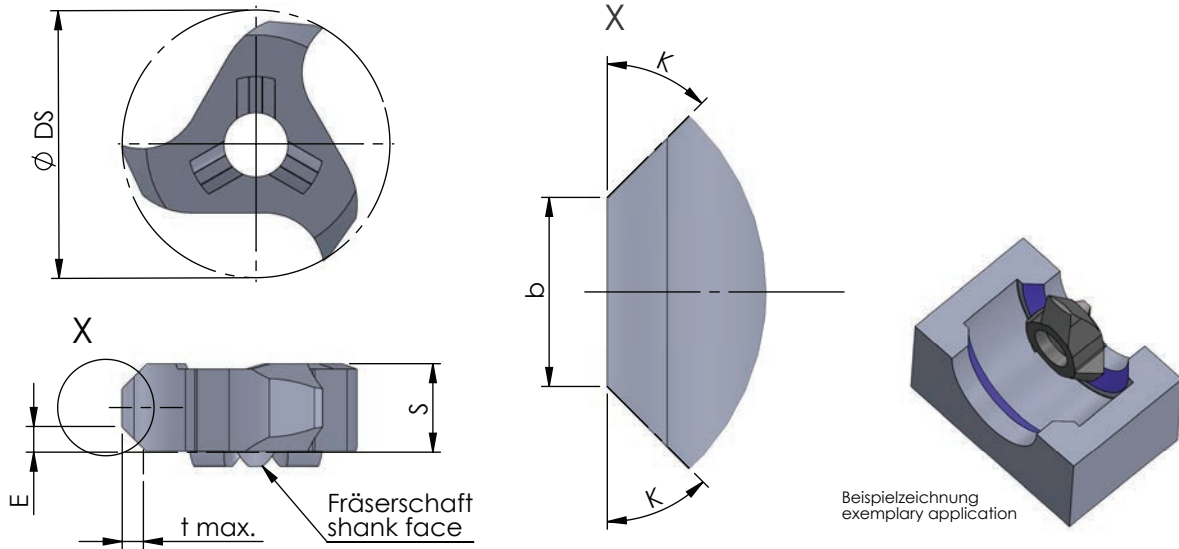

Abmessungen in mm

dimensions in mm

Bestellnummer part number	K	D min.	S	E	$\varnothing DS$	b	t max.	Zähnezahl number of teeth	Material			für Fräseschaft for milling shank
									K10F	AL41F	P18C	
Z22.4545.58	45°	22	5.85	2.0	21.7	2.0	1.7	3	●			
Z22.4545.94 *	45°	22	9.4	3.25	21.7	3.0	3.0	3	●			ZH22...

Weitere HM Sorten können Sie in der Sortenübersicht im Kapitel "Technische Hinweise" und der Preisliste finden.

\*Achtung: für diesen Schneideinsatz Sonderschraube M5/16-MM

Best.beisp.: für Sorte AL41F: Z22.4545.58/AL41F

More carbide grades you can find in the grades summary in the chapter "technical instructions" and in the price list.

\*attention: this insert needs special screw M5/16-MM

order-example: grade AL41F: Z22.4545.58/AL41F

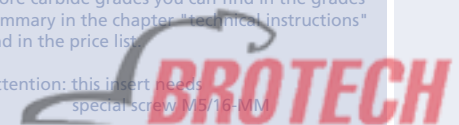

**MINIMILL**

Nut- und Formzirkularfräsen

groove milling by circular interpolation

**Typ Z618 / Z622 / Z628**

Vorwärts- und Rückwärtsfasen

forward & backward chamfering

D min. 15 - 28 mm

D min. 15 - 28 mm

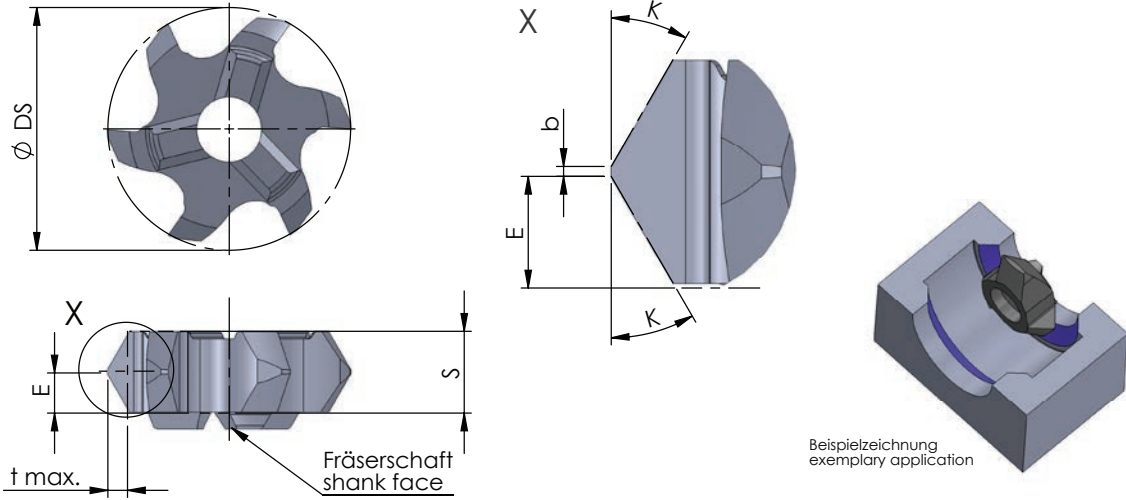

Abmessungen in mm

dimensions in mm

Bestellnummer part number	K	D min.	S	E	Ø DS	b	t max.	Zähnezahl number of teeth				für Fräseschaft for milling shank
									K10F	AL41F	P18C	
Z618.4545.DS15	45°	15	5.75	2.75	14.7	0.5	1.6	6	●			ZH18...
Z618.4545.58	45°	18	5.75	2.9	17.7	0.2	2.2	6	●			ZH18...
Z622.4545.63	45°	22	6.05	3.7	21.7	0.2	2.0	6	●			ZH22...
Z628.4545.02	45°	28	6.50	3.7	27.7	0.2	2.0	6	●			ZH28...

Weitere HM Sorten können Sie in der Sortenübersicht im Kapitel "Technische Hinweise" und der Preisliste finden.

Bestellbeispiel:  
für Sorte AL41F:  
Z618.4545.58/AL41F

More carbide grades you can find in the grades summary in the chapter "technical instructions" and in the price list.

order example:  
grade AL41F:  
Z618.4545.58/AL41F



# MINIMILL

Nut- und Formzirkularfräsen

groove milling by circular interpolation

# Typ Z620 / Z628

Stirn- und Planfräsen

face milling

D min. 20 / 28 mm

D min. 20 / 28 mm

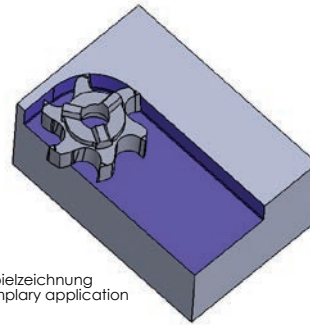
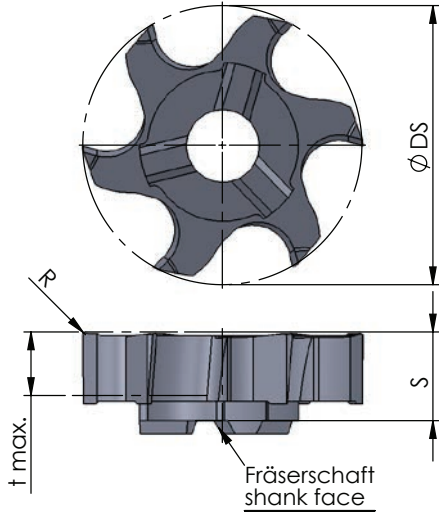

Beispielzeichnung  
exemplary application

Abmessungen in mm

dimensions in mm

Bestellnummer part number	D min.	S	R	Ø DS	t max.	Zähnezahl number of teeth	Material			für Frälerschaft for milling shank
							K10F	AL41F	P18C	
Z620.SP50.02	20	6.2	0.2	19.7	5.0	6	●			ZH22...
Z628.SP50.02	28	6.2	0.2	27.7	5.0	6		●		ZH28...

Weitere HM Sorten können Sie in der Sortenübersicht im Kapitel "Technische Hinweise" und der Preisliste finden.

Bestellbeispiel:  
für Sorte AL41F:  
Z620.SP50.02/AL41F

More carbide grades you can find in the grades summary in the chapter "technical instructions" and in the price list.

order example:  
grade AL41F:  
Z620.SP50.02/AL41F



## MINIMILL

Nut- und Formzirkularfräsen

groove milling by circular interpolation

## Sets

D min. 12 mm

D min. 18 mm

Bestellnummer  
part number

Inhalt  
Content

K10F  
AL41F  
P18C

### SET-MINI-MILLZ12



- Sicherungsringe DIN471/472 und Nutfräsen allgemein
- Nutfräsen Vollradius
- Vorwärts- und Rückwärtsfasen

- for circlips DIN471/472, groove milling general use
- groove milling full radius
- forward & backward chamfering

**Fräseschaft / milling shank:**

1 x ZH10.1606.12.B.ST

**Schneideinsatz / insert:**

1 x Z12.0150.02

1 x Z12.0200.00

1 x Z12.0011.22

1 x Z12.4545.35



Bestellnummer  
part number

Inhalt  
Content

K10F  
AL41F  
P18C

### SET-MINI-MILLZ18



- Sicherungsringe DIN471/472 und Nutfräsen allgemein
- Nutfräsen Vollradius
- Vorwärts- und Rückwärtsfasen

- for circlips DIN471/472, groove milling general use
- groove milling full radius
- forward & backward chamfering

**Fräseschaft / milling shank:**

1 x ZH18.1609.18.B.ST

**Schneideinsatz / insert:**

1 x Z18.0150.00

1 x Z18.0300.02

1 x Z18.0011.22

1 x Z18.4545.58



## MINIMILL

Nut- und Formzirkularfräsen

groove milling by circular interpolation

## Sets

D min. 22 mm

D min. 37 mm



	Bestellnummer part number	Inhalt Content	K10F AL41F P18C
	<p><b>SET-MINI-MILLZ22</b></p> <ul style="list-style-type: none"> <li>• Nutfräsen allgemein</li> <li>• Nutfräsen Vollradius</li> <li>• Vorwärts- und Rückwärtsfasen</li> </ul> <ul style="list-style-type: none"> <li>• groove milling general use</li> <li>• groove milling full radius</li> <li>• forward &amp; backward chamfering</li> </ul>	<p><b>Frälerschaft / milling shank:</b> 1 x ZH22.1612.24.B.ST</p> <p><b>Schneideinsatz / insert:</b> 1 x Z622.0150.01 1 x Z622.0400.02 1 x Z22.0014.28 1 x Z22.4545.58</p>	<p>● ● ● ●</p>
	<p><b>SET-MINI-MILLZ637</b></p> <ul style="list-style-type: none"> <li>• Nutfräsen allgemein</li> <li>• Spannschraube Klemmhalter</li> </ul> <ul style="list-style-type: none"> <li>• groove milling general use</li> <li>• screw milling shank</li> </ul>	<p><b>Frälerschaft / milling shank:</b> 1 x ZH22.1612.24.B.ST</p> <p><b>Schneideinsatz / insert:</b> 2 x Z637.0150.01</p> <p><b>Spannschraube / screw:</b> 1x M5-MM</p>	<p>●</p>

Bestellbeispiel:  
SET-MINI-MILLZ22



## MINIMILL

Nut- und Formzirkularfräsen

groove milling by circular interpolation

## Impressionen

impressions

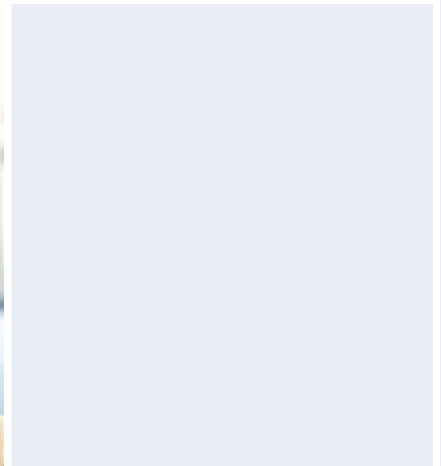
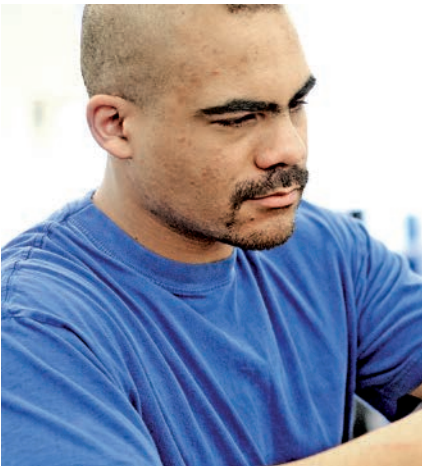
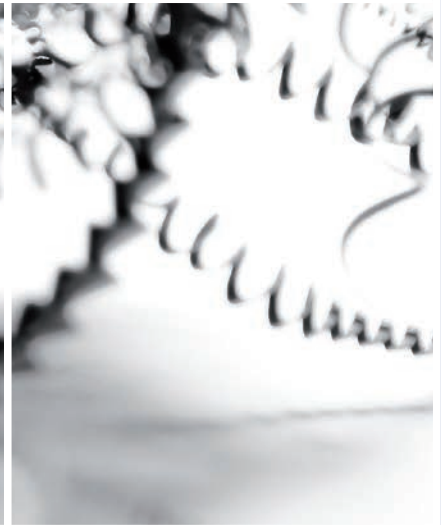
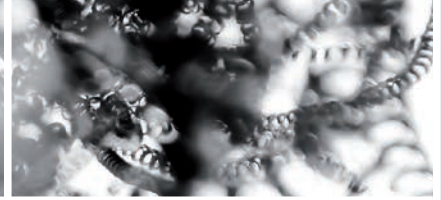

## MINIMILL

Nut- und Formzirkularfräsen

groove milling by circular interpolation

## Technische Hinweise

Grundsätzliche Informationen zum Gewindefräsen

Technical instructions,  
basic informations about thread milling

### Vor- und Nachschnitt

Beim Zirkularfräsen von Gewinden entsteht durch die Steigung ein Vor- und Nachschnitt. Um hier die Verletzung des Gewindepfels so gering wie möglich zu halten muß ein Werkzeug mit einem möglichst kleinen Schneidkreis gewählt werden.

Die nachfolgende Skizze zeigt die Verhältnisse bei der Bearbeitung:

(Grün: Konturverletzung X gering = gut; Rot: Konturverletzung X erheblich = schlecht)

#### Thread profile violation

Thread milling by interpolation causes a profile violation. To keep the violation minimal you should use the cutting circle as small as possible.

The following sketch shows the relations during the process:

(green: profile violation X low = good; red: profile violation X big = bad)

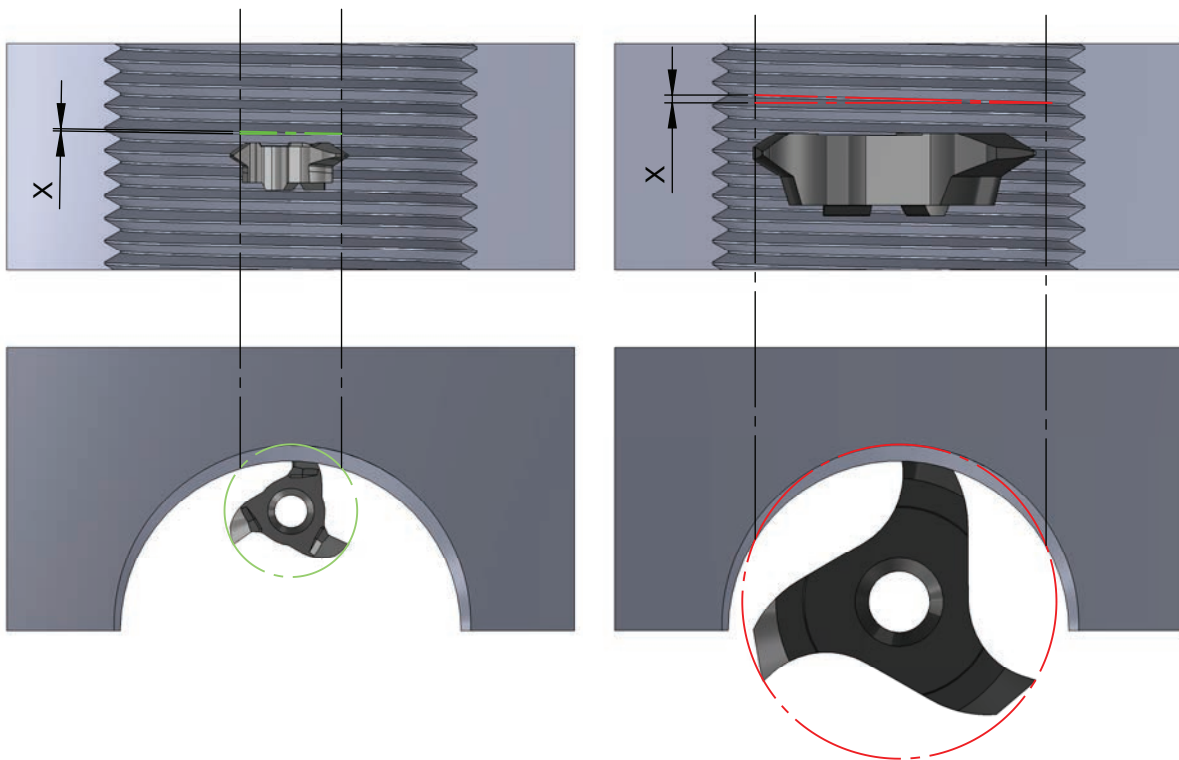

## MINIMILL

Nut- und Formzirkularfräsen

groove milling by circular interpolation

## Technische Hinweise

Grundsätzliche Informationen zum Gewindefräsen

Technical instructions,  
basic informations about thread milling

### Teilprofil

Werkzeuge mit Teilprofil sind Mehrbereichswerkzeuge, d.h. mit diesem Werkzeug können Gewinde mit unterschiedlichen Steigungen hergestellt werden. Dies ist aber nur mit einer kleinen Abweichung vom Normprofil möglich. Abgestimmt ist das Werkzeug auf die kleinste angegebene Steigung, dieses Profil kann ohne Abweichung produziert werden. Alle weiteren Steigungen können ebenfalls produziert werden, hier weicht aber das gefertigte Profil gegenüber der Norm durch eine höhere Gewindetiefe ab. In der Regel ist dies unproblematisch, muß aber gegebenenfalls im Einzelfall genauer betrachtet werden.

#### Partial profile

Tools with partial profile are multi-purpose tools, that means you can process several pitches with one tool. The processed shape has a small difference to the standard profile. Created is that tool for the smallest pitch, this profile depends to the standard.

All other pitches are producible, but only with a small deviation. Normally this causes no problem, but sometimes you have to decide case by case.

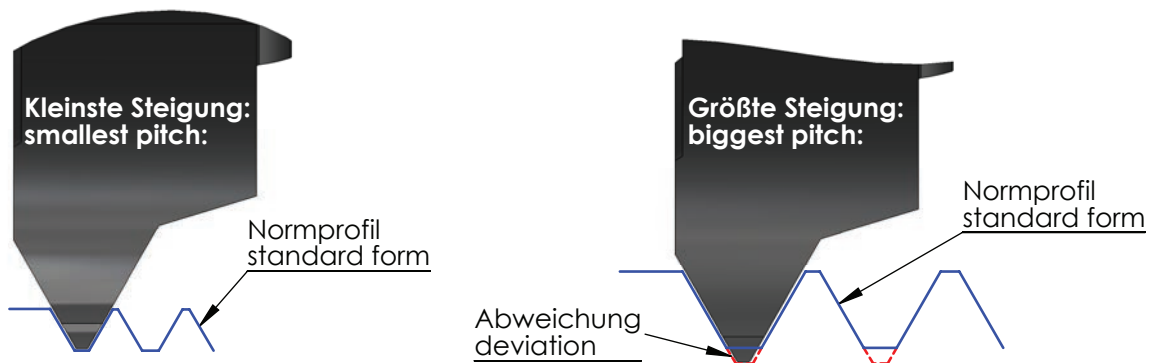

## MINIMILL

Nut- und Formzirkularfräsen

groove milling by circular interpolation

## Technische Hinweise

Grundsätzliche Informationen zum Gewindefräsen

Technical instructions, basic informations about thread milling

## Auswahlhilfe Mehrbereichswerkzeuge

In der nachfolgenden Tabelle sind alle DÜMMEL - Mehrbereichswerkzeuge aufgeführt. Anhand dieser Tabelle können Sie den jeweiligen Einsatzbereich entnehmen (blau= optimale Kontur, grau= mögliche Konturen):

### Selection guide multi-purpose-tools

In the following chart are all DÜMMEL - multi-purpose-tools listed. This chart shows the possible area of application (blue= optimal profile; grey= possible profiles):



ab Gewindegröße / starting with thread-size	Steigung (mm)/ pitch (mm)															
	1	1,25	1,5	1,75	2	2,5	2,75	3	3,5	3,75	4	4,5	5	5,5	6	
Z610.0510.01	M12	M13	M14	M14												
Z610.0720.01	M13	M13	M14	M14	M15											
Z610.0815.01			M15	M15	M16	M18	M18									
Z610.2530.01					M16	M18	M18	M19								
Z12.0510.01	M14	M15	M15	M16												
Z12.0720.01	M14	M15	M15	M16	M16											
Z12.0815.01			M15	M16	M16	M17	M17									
Z12.2530.01					M16	M17	M17	M18								
Z614.0510.01	M15	M15	M16	M16												
Z614.0720.01	M15	M15	M16	M17	M17											
Z614.0815.01			M17	M17	M18	M20	M21									
Z614.2530.01					M18	M20	M21	M21								
Z16.0510.01	M18	M19	M20	M20												
Z16.0720.01	M18	M19	M20	M20	M21											
Z16.0815.01			M20	M20	M21	M21	M22									
Z16.2530.01					M21	M21	M22	M22								
Z18.0510.01	M21	M21	M22	M22												
Z18.0720.01/Z618.0720.01	M21	M21	M22	M22	M23											
Z18.0815.01			M22	M22	M23	M24	M24									
Z18.1325.01					M23	M24	M24	M24								
Z18.2535.01/Z618.2545.01					M23	M24	M24	M24	M25							
Z18.1020.01					M23	M24	M24	M24	M25	M26						
Z18.1630.01						M24	M24	M24	M25	M26	M26	M27	M28			
Z18.1835.01								M24	M25	M26	M26	M27	M28	M28		
Z22.0720.01/Z622.0720.01	M25	M25	M25	M26	M27											
Z22.0815.01			M26	M26	M27	M28	M28									
Z22.1020.01					M27	M28	M28	M29	M30	M30						
Z22.2545.01/Z622.2545.01					M27	M28	M28	M29	M30	M30	M30	M31				
Z22.1630.01						M28	M28	M29	M30	M30	M30	M31	M32			
Z22.2140.01									M30	M30	M30	M31	M32	M33	M34	
Z22.2445.01									M30	M30	M30	M31	M32	M33	M34	
Z28.0720.01	M31	M31	M32	M32	M33											
Z28.1525.01/Z628.1525.01			M32	M32	M33	M34										
Z28.3050.01/Z628.3050.01						M34	M35	M35	M36	M36	M37	M38	M39			
Z28.5060.01											M37	M38	M39	M39	M40	

## MINIMILL

Nut- und Formzirkularfräsen

groove milling by circular interpolation

## Technische Hinweise

Hartmetallsorten und Beschichtungen

Technical instructions, carbide grades and coatings

### K10F

Universell einsetzbares Feinkornhartmetall mit guter Verschleißfestigkeit. Unbeschichtet geeignet für Anwendungen mit niedrigen und mittleren Schnittgeschwindigkeiten, sowie die Bearbeitung von Nicht-eisenmetallen.

All purpose micrograin carbide with good abrasion resistance. Uncoated for applications with low or medium cutting speeds and machining of non-ferrous materials.

### CBN

Zähe CBN-Sorte für Anwendungen mit niedrigen Schnittgeschwindigkeiten. Geeignet für gehärtete Stähle, unterbrochene Schnitte und Grauguss.

Ductile CBN grade for applications with lower cutting speed. Suitable for hardened steel, interrupted cuts and cast iron.

### CN45F

Universell einsetzbare PVD-TiN-Beschichtung. Diese Allround-Sorte ist für niedrige und mittlere Schnittgeschwindigkeiten mit Einschränkung bei NE-Metallen

PVD-TiN coating - all purpose, all around grade is suitable for low and medium cutting speed with restrictions on non-ferrous materials.

### AL41F

Sehr universell einsetzbare TiAlN-Beschichtung mit hoher Temperaturbeständigkeit bei hoher Härte. Sehr gut geeignet auch für NE-Metalle.

TiAlN coating - very universal with a high resistance to high temperature and hardness. Very suitable also for non-ferrous metals.

### PD2F

Beschichtung für den universellen Einsatz bei niedrigen und mittleren Schnittgeschwindigkeiten.

Coating for universal use with medium and low speed.

### XC2A

Beschichtung mit einer excellenten Warmhärte, Oxidationsbeständigkeit und thermischen Isolationsfähigkeit. Ideal für Hartzerspannung >60HRC

Coating with excellent hot hardness, high oxidation resistance and thermal insulation capacity. Perfect for hard machining >60 HRC.

## MINIMILL

Nut- und Formzirkularfräsen

groove milling by circular interpolation

## Technische Hinweise

Hartmetallsorten und Beschichtungen

Technical instructions, carbide grades and coatings

### P01C

Beschichtung für die Bearbeitung in zähen Materialien bei niedrigen und mittleren Schnittgeschwindigkeiten.

Coating for the processing in tough material with medium or low cutting speed

### P03C

Beschichtung für die Bearbeitung von schwer zerspanbaren Materialien. Sehr gut auch für die Trockenbearbeitung geeignet.

Coating for materials which are difficult to machine. Perfect to use for dry machining.

### P07C

Beschichtung für die Bearbeitung von Titan, Edelstahl und Molybdän.

Coating to machine titanium, stainless steel and molybdenum.

### P18C

Universell einsetzbare Hochleistungsschicht mit hoher Oxidationsbeständigkeit, Verschleißfestigkeit und Warmhärte.

Very universal high performance coating with high oxidation resistance, wear resistance and hot hardness resistance.

### NEME

Beschichtung für die Bearbeitung von Aluminium, Al-Legierungen, NE-Metallen und Composite-Werkstoffen.

Coating for machining aluminium, alloys, non-ferrous metals and composite materials.



## MINIMILL

Nut- und Formzirkularfräsen

groove milling by circular interpolation

## Technische Hinweise

Ermittlung der Schnittdaten für das Nut- und Formzirkularfräsen

Technical instructions, evaluation of the cutting data for groove milling

$$n = \frac{V_c \cdot 1000}{d \cdot \pi} \quad V_{\text{eff}} = f_z \cdot z \cdot n \quad f_z = h_m \sqrt{\frac{d}{a_e}}$$

Fräsen Außenkontur  
milling external

$$V_{\text{prog}} = \frac{V_{\text{eff}} \cdot (D + d)}{D}$$

$$V_{\text{eff}} = \frac{D \cdot V_{\text{prog}}}{(D + d)}$$

Fräsen Innenkontur  
milling internal

$$V_{\text{prog}} = \frac{V_{\text{eff}} \cdot (D - d)}{D}$$

$$V_{\text{eff}} = \frac{D \cdot V_{\text{prog}}}{(D - d)}$$

Formel-Zeichen  
formula characters

Bezeichnungen  
specifications

Einheit  
unit

**d**

Fräserdurchmesser  
milling diameter

mm

**D**

Gewindedurchmesser  
thread diameter

mm

**V<sub>eff</sub>**

effektive Vorschubgeschwindigkeit  
(auf / an der Kontur)  
feed rate of tool tip

mm / min

**V<sub>eint</sub>**

programmierter Eintauchvorschub  
programmed plunge feed

mm / min

**V<sub>prog</sub>**

programmierte Vorschubgeschwindigkeit  
feed rate of tool center

mm / min

**z**

Schneidenzahl Fräser  
number of cutting edges

Stk.  
pcs.

Nach Möglichkeit immer im Kreisbogen eintauchen.

Always plunge in a circular arc where possible.

Beim geraden Eintauchen nur 1/3 des Vorschubs verwenden und erst beim Erreichen der Frästiefe vollen Vorschub fahren.

When plunging straight use only 1/3 of the feed and do not traverse full feed until reaching the milling depth.

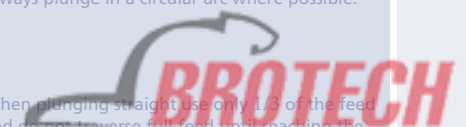

## MINIMILL

Nut- und Formzirkularfräsen

groove milling by circular interpolation

## Technische Hinweise

Ermittlung der Schnittdaten für das Nut- und Formzirkularfräsen

Technical instructions, evaluation of the cutting data for groove milling

$$n = \frac{V_c \cdot 1000}{d \cdot \pi}$$

$$V_f = n \cdot z \cdot f_z \text{ mm/min}$$

$$f_z = h_m \sqrt{\frac{2r}{a_e}}$$

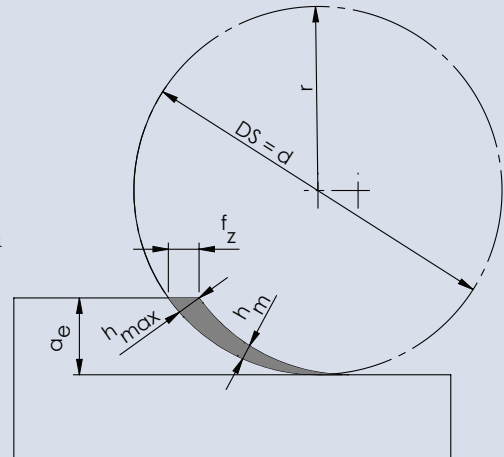

Formel-Zeichen  
formula characters

Bezeichnungen  
specifications

Einheit  
unit

$a_e$

Spantiefe radial  
radial depth of cut

mm

$f_z$

Vorschub pro Zahn  
feed / tooth

mm

$h_m$

mittlere Spandicke  
medium thickness of chip

mm

$h_{max}$

maximale Spandicke  
maximum thickness of chip

mm

$n$

Spindeldrehzahl  
revolutions

U / min

$r$

Radius Fräser  
radius of cutter

mm

$V_c$

Schnittgeschwindigkeit  
cutting speeds

m / min

$V_f$

Vorschubgeschwindigkeit  
feed rate of tool center

mm / min

$z$

Schneidenzahl Fräser  
number of cutting edges

Stk.  
pcs.



# MINIMILL

Nut- und Formzirkularfräsen

groove milling by circular interpolation

# Technische Hinweise

Schnittdaten

Technical instructions, cutting data

	Werkstoff	Festigkeit	Werkstoff-Nr	Werkstoffbezeichnung	Werkstoff-Nr	
P	Allgemeiner Baustahl	< 800 N/mm <sup>2</sup>	1.0037	St37-2	1.0570	
	Automatenstahl	< 800 N/mm <sup>2</sup>	1.0718	9SMnPb28	1.0727	
	Einsatzstahl unlegiert	< 800 N/mm <sup>2</sup>	1.0401	C15	1.0481	
	Einsatzstahl legiert	< 1000 N/mm <sup>2</sup>	1.7331	16MnCr5 (EC80)	1.7015	
	Vergütungsstahl unlegiert	< 850 N/mm <sup>2</sup>	1.0503	C45	1.1191	
	Vergütungsstahl unlegiert	< 1000 N/mm <sup>2</sup>	1.0601	C60	1.1221	
	Vergütungsstahl legiert	< 800 N/mm <sup>2</sup>	1.5131	50MnSi4	1.7030	
	Vergütungsstahl legiert	< 1300 N/mm <sup>2</sup>	1.5755	31NiCr14	1.7033	
	Stahlguss	< 850 N/mm <sup>2</sup>	0.9650	G-X260Cr27	1.6750	
	Nitrierstahl	< 1000 N/mm <sup>2</sup>	1.8504	34CrAl6	1.8507	
	Nitrierstahl	< 1200 N/mm <sup>2</sup>	1.8515	31CrMo12	1.8523	
	Wälzlagerstahl	< 1200 N/mm <sup>2</sup>	1.3505	100Cr6 (W3)	1.3543	
	Federstahl	< 1200 N/mm <sup>2</sup>	1.5026	55Si7	1.7176	
	Schnellarbeitsstahl	< 1300 N/mm <sup>2</sup>	1.3344	S 6-5-3	1.3255	
	Werkzeugstahl für Kaltarbeit	< 1300 N/mm <sup>2</sup>	1.2312	40CrMnMoS8 6	1.2379	
	Werkzeugstahl für Warmbeit	< 1300 N/mm <sup>2</sup>	1.2343	X38CrMoV 5 1	1.2767	
	M	Stahl und Stahlguss rostfrei geschwefelt	< 850 N/mm <sup>2</sup>	1.4305	X8CrNiS18 9	1.4105
		Nichtrostender Stahl, ferritisch	< 750 N/mm <sup>2</sup>	1.4510	X3CrTi17	1.4528
Nichtrostender Stahl, martensitisch		< 900 N/mm <sup>2</sup>	1.4034	X46Cr13	1.4116	
Nichtrost. Stahl, ferritisch/martensit.		<1100 N/mm <sup>2</sup>	1.4313	X3CrNi13-4	1.4028	
Nichtrost. Stahl, austenitisch/ferritisch		< 850 N/mm <sup>2</sup>	1.4460	X8CrNiMo27 5	1.4821	
Nichtrostender Stahl, austenitisch		< 750 N/mm <sup>2</sup>	1.4301	X5CrNi18-10	1.4571	
Hitzebeständig		< 1100 N/mm <sup>2</sup>	1.4747	X80CrNiSi20	1.4876	
K	Grauguss mit Lammellengraphit	100-350N/mm <sup>2</sup>	0.6010	GG10	0.6025	
	Grauguss mit Lammellengraphit	300-1000N/mm <sup>2</sup>	0.6030	GG30	0.6045	
	Kugelgraphitguss	300-500N/mm <sup>2</sup>	0.7040	GGG40	0.7050	
	Kugelgraphitguss	550-800N/mm <sup>2</sup>	0.7060	GGG60	0.7080	
	Temperguss weis	350-450N/mm <sup>2</sup>	0.8035	GTW35	0.8045	
	Temperguss weis	500-650N/mm <sup>2</sup>	0.8055	GTW55	0.8065	
	Temperguss schwarz	350-450N/mm <sup>2</sup>	0.8135	GTS35	0.8145	
Temperguss schwarz	500-700N/mm <sup>2</sup>	0.8155	GTS55	0.8170		
N	Aluminium ( unlegiert, niedrig legiert )	< 350 N/mm <sup>2</sup>	3.0255	Al99,5	3.3308	
	Aluminiumlegierungen < 0,5% Si	< 500 N/mm <sup>2</sup>	3.0515	AlMn1	3.1355	
	Aluminiumlegierungen 0,5-10% Si	< 400 N/mm <sup>2</sup>	3.2152	GD-AlSi6Cu4	3.2373	
	Aluminiumlegierungen 10-15% Si	< 400 N/mm <sup>2</sup>	3.2381	G-AlSi10Mg	3.5562	
	Aluminiumlegierungen > 15% Si	< 400 N/mm <sup>2</sup>		G-AlSi17Cu4		
	Kupfer ( unlegiert, niedrig legiert )	< 350 N/mm <sup>2</sup>	2.0060	E-Cu57	2.0090	
	Kupfer-Knetlegierungen	< 700 N/mm <sup>2</sup>	2.0240	CuZn15	2.0265	
	Kupfer-Sonderlegierungen	< 200 HB	2.0916	CuAl5	2.1525	
	Kupfer-Sonderlegierungen	< 300HB	2.0978	CuAl11Ni6Fe5		
	Kupfer-Sonderlegierungen	> 300 HB	2.1247	CuBe2F125		
	Messing kurzspanend, Bronze, Rotguss	< 600 N/mm <sup>2</sup>	2.0360	CuZn40 (Ms60)	2.0380	
	Messing langspanend	< 600 N/mm <sup>2</sup>	2.0335	CuZn36 (Ms63)	2.1293	
	Thermoplaste			Delrin, Hostalen		
	Duroplaste			Ferrozell, Bakelit		
	Faserverstärkte Kunststoffe			GFK (Glasfaserverstärkt )		
	Magnesium und Magnesiumlegierungen	< 850 N/mm <sup>2</sup>	3.5200	M2, MgMn2	3.5612	
	Graphit			C8000, R8500X		
	Wolfram und Wolframlegierungen			W-NiFe (Densimet W)		
Molybdän und Molybdänlegierungen			Mo , Mo-50Re			
S	Reinnickel		1.3911	RNi24	1.3927	
	Nickellegierungen		1.3912	Ni36 (Invar)	1.3924	
	Nickellegierungen	< 850 N/mm <sup>2</sup>	2.4360	S-NiCu 30 Fe		
	Nickel-Chromlegierungen		2.4886	SG-NiMo16Cr16W	2.4610	
	Nickel- und Kobaltlegierungen	< 1300 N/mm <sup>2</sup>	2.4632	NiCr20Co18Ti	2.4631	
	Nickel- und Kobaltlegierungen	< 1300 N/mm <sup>2</sup>	2.4634	NiCo20Cr15MoAlTi	2.4654	
	Hochwärmefeste Legierungen	< 1300 N/mm <sup>2</sup>		Hardox 400	1.4939	
	Nickel-Kobalt-(Chrom-)legierungen	< 1400 N/mm <sup>2</sup>	2.4806	SG-NiCr20Nb, Inconel 82	2.4851	
	Reintitan	< 900 N/mm <sup>2</sup>	3.7025	Ti99,8	3.7034	
	Titanlegierungen	< 700 N/mm <sup>2</sup>	3.7114	TiAl5Sn2	3.7174	
	Titanlegierungen	< 1200 N/mm <sup>2</sup>	3.7164	TiAl5V4	3.7144	
H	Stahl gehärtet	< 45 HRc				
		46-55HRc				
		56-60 HRc				
		61-65 HRc				
		65-70 HRc				

# MINIMILL

Nut- und Formzirkularfräsen

groove milling by circular interpolation

# Technische Hinweise

Schnittdaten

Technical instructions, cutting data



Werkstoffbezeichnung	Werkstoff- Nr	Werkstoffbezeichnung	Vc (m/min.)	fz (mm)	h max. (mm)	mit/with AL41F		
St52-3	1.0060	St60-2	80-200	0,03 - 0,10	0,03-0,05	Haupt-Anwendung		
45S20	1.0757	46SPb2		0,03 - 0,10	0,03-0,05			
17Mn4	1.1141	C15E (CK15)		0,03 - 0,10	0,03-0,05			
13Cr3 (EC60)	1.5919	15CrNi6	60-180	0,03 - 0,08	0,03-0,05			
Ck45	1.0535	C55		0,03 - 0,08	0,03-0,05			
Ck60	1.0540	C50		0,03 - 0,08	0,03-0,05			
28Cr4	1.7225	42CrMo4	60-160	0,03 - 0,10	0,03-0,05			
34Cr4	1.3565	48CrMo4		0,02 - 0,07	0,03-0,05			
GS-20NiCrMo3 7	1.6582	GS-34 CrNiMo 6		0,03 - 0,10	0,03-0,05			
34AlMo5	1.8509	41CrAlMo7	30-100	0,03 - 0,10	0,03-0,05			
39CrMoV19 3	1.8550	34 CrAlNi 7		0,02 - 0,08	0,03-0,05			
X192CrMo17	1.3520	100 CrMn 6 (W4)		0,02 - 0,07	0,03-0,05			
55Cr3	1.7701	51CrMoV4	80-120	0,02 - 0,07	0,03-0,05	Haupt-Anwendung		
S 18-1-2-5	1.3294	PMH56-5-3-8; ASP30		0,02 - 0,07	0,03-0,05			
X155CrVMo12 1	1.2316	X38CrMo16; RAMAX		0,02 - 0,07	0,03-0,05			
X45NiCrMo4	1.2842	90MnCrV8	100-170	0,02 - 0,07	0,03-0,05			
X4CrMoS18	1.4107	GX8CrNi12		0,03 - 0,08	0,03-0,05			
X105CrCoMo18 2	1.4016	X6Cr17		0,03 - 0,10	0,03-0,05			
X50CrMoV15	1.4106	X2CrMoSiS18-2-1	250-800	0,02 - 0,07	0,03-0,05		Haupt-Anwendung	
X30Cr13	1.4104	X14CrMoS17		0,02 - 0,07	0,03-0,05			
X20CrNiSi25 4	1.4462	X2CrNiMoN22-5-3 (Duplex)		0,02 - 0,07	0,03-0,05			
X6CrNiMoTi17 12 2	1.4449	X3CrNiMo18-12-3	200-500	0,02 - 0,07	0,03-0,05			
X10NiCrAlTi32-21	1.4825	GX25CrNiSi18-9		0,04 - 0,15	0,03-0,05			
GG25				0,03 - 0,10	0,03-0,05			
GG45			150-180	0,03 - 0,10	0,03-0,05	Haupt-Anwendung		
GGG50				0,03 - 0,10	0,03-0,05			
GGG80				0,03 - 0,10	0,03-0,05			
GTW45			10-100	0,03 - 0,10	0,03-0,05			Neben-Anwendung
GTW65				0,03 - 0,10	0,03-0,05			
GTS45				0,03 - 0,10	0,03-0,05			
GTS70			20-100	0,03 - 0,10	0,03-0,05			
Al99,9Mg0,5	3.0256	E-Al H		0,04 - 0,15	0,03-0,05			
AlCuMg2	3.3315	AlMg1		0,04 - 0,15	0,03-0,05			
GD-AlSi9Mg	3.2134	GD-AlSi5Cu1Mg	10-60	0,04 - 0,15	0,03-0,05		Neben-Anwendung	
G-MgAl6	3.2525	S-AlSi12		0,04 - 0,15	0,03-0,05			
G-AlSi25CuNiMg		G-AlSi21CuNiMg		0,04 - 0,15	0,03-0,05			
SF-Cu	2.1522	CuSi2Mn	-	0,04 - 0,15	0,03-0,05			
CuZn30	2.0321	CuZn37		0,04 - 0,15	0,03-0,05			
CuSi3Mn		Ampco 8-16		0,04 - 0,15	0,03-0,05			
		Ampco18-26	-	0,04 - 0,15	0,03-0,05			
		Ampco M-4		0,04 - 0,15	0,03-0,05			
CuZn39Pb2 (Ms58)	2.0410	CuZn44Pb2		0,04 - 0,15	0,03-0,05			
CuCrZr	2.1080	CuSn6Zn6	-	0,04 - 0,15	0,03-0,05			
Makrolon, Novodur		Acrylglas, Polystyrol		0,04 - 0,15	0,03-0,05			
Pertinax		Resopal		0,04 - 0,15	0,03-0,05			
CFK (Kohlefaserverstärkt)		AFK (Amidfaserverstärkt)	-	0,04 - 0,15	0,03-0,05			
MgAl6Zn1	3.5812	MgAl8Zn1		0,02 - 0,10	0,03-0,05			
R8650		Technograph15		0,04 - 0,15	0,03-0,05			
W-Cu80/20		W93NiFe (DENAL)	-	0,02 - 0,10	0,03-0,05			
TZC, TZM		MHC , ODS		0,02 - 0,10	0,03-0,05			
RNi8	1.3926	RNi12	10-100	0,005 - 0,05	0,03-0,05	Neben-Anwendung		
Ni54	1.3921	Ni49		0,005 - 0,05	0,03-0,05			
NiCu 30 Fe		Monel 400		0,005 - 0,05	0,03-0,05			
NiMo16Cr16Ti		Hastelloy C-276		0,005 - 0,05	0,03-0,05			
NiCr20TiAl		Nimonic 80		0,005 - 0,05	0,03-0,05			
NiCr19Co14Mo4Ti		Waspaloy		0,005 - 0,05	0,03-0,05			
X12CrNiMo12	1.4980	X6NiCrTiMoVB25-15-2		0,005 - 0,05	0,03-0,05			
NiCr23Fe, Inconel 601	2.4667	SG-NiCr19NbMoTi		0,005 - 0,05	0,03-0,05			
Ti99,7	3.7064	Ti99,5		0,005 - 0,05	0,03-0,05			
TiAl6V6Sn2	3.7124	TiCu2		0,005 - 0,05	0,03-0,05			
TiAl6Sn2Zr4Mo2	3.7154	TiAl6Zr5		0,005 - 0,05	0,03-0,05			
				-	0,002 - 0,05			
			0,002 - 0,05					
			0,002 - 0,05					





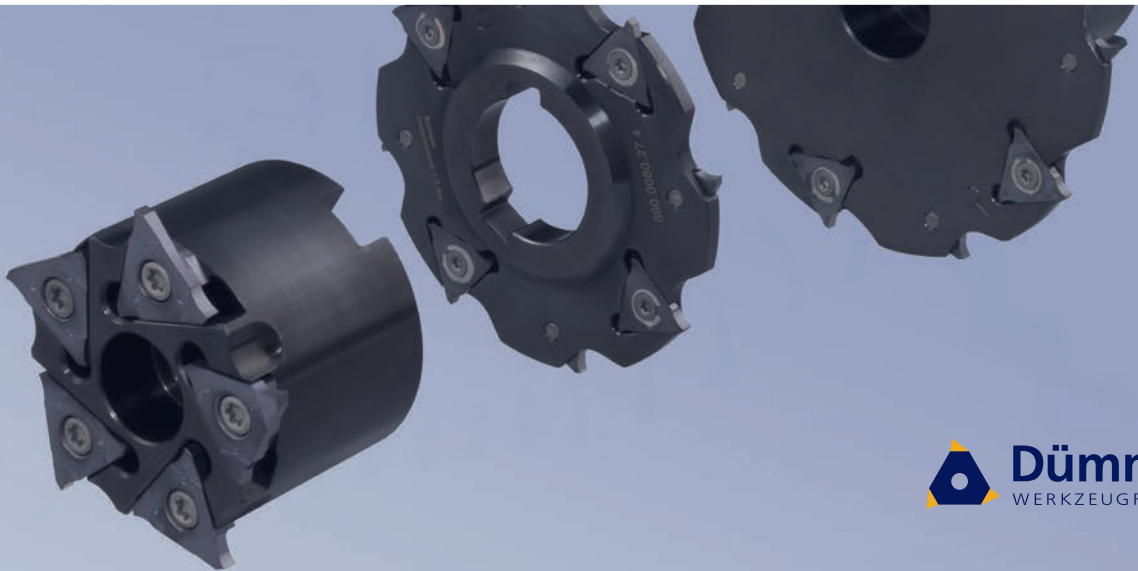

**SYSTEM 500**



**Nut- und Formfräsen  
Nut- und Trennfräsen**

**Groove milling by circular interpolation  
Groove milling and slotting cutter**



## SYSTEM 500

Nut- und Trennfräsen

groove milling  
and slotting cutter

## Übersicht

summary

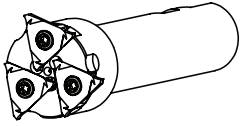

Allgemeine Beschreibung

general instructions

... 434

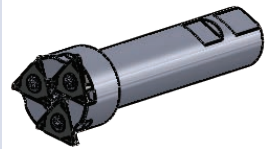

### Messerköpfe

### milling cutter type

### Maße dimensions

### Seite page

<b>500.44.3</b>	Fräuserschaft	milling shank	D min. 45 t max. 4.0	... 435
<b>510.0063.05-D</b>	Messerkopf	milling cutter	D min. 64 t max. 5.0	... 436
<b>510.0080.08-D</b>	Messerkopf	milling cutter	D min. 81 t max. 5.0	... 437
<b>581...</b>	Messerkopf	milling cutter	D min. 64 t max. 5.0	... 438



### Fräswendeschneidplatten

### indexable milling inserts

### Maße dimensions

### Seite page

<b>Typ 514</b>	für Sicherungsringe DIN 471/472 für Typ 500 / Typ 510 / Typ 581	for circlips DIN 471/472 for type 500 / Typ 510 / Typ 581		... 439
<b>Typ 514</b>	für Sicherungsringe DIN 471/472, mit Nutaußenkantenfasung für Typ 500 / Typ 510 / Typ 581	for circlips DIN 471/472, with chamfer for type 500 / type 510 / type 581		... 440
<b>Typ 514</b>	metrisches ISO-Gewinde, Teilprofil, innen für Typ 500 / Typ 510 / Typ 581	metric ISO-thread, partial profile, internal for type 500 / type 510 / type 581	Steigung / pitch P = 1.5 - 6.0	... 441
<b>Typ 514</b>	metrisches ISO-Gewinde, Vollprofil, innen für Typ 500 / Typ 510 / Typ 581	metric ISO-thread, full profile, internal for type 500 / type 510 / type 581	Steigung / pitch P = 1.5 - 5.5	... 442

## SYSTEM 500

Nut- und Trennfräsen

groove milling  
and slotting cutter

## Übersicht

summary

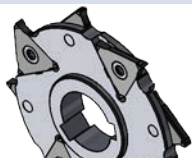

**Hochleistungsscheibenfräser  
mit Wendeschneidplatten  
Breite 6 / 8 / 10 mm**

**high performance  
disk-milling cutter  
with indexable inserts  
width 6 / 8 / 10 mm**

**Maße  
dimensions**

**Seite  
page**

**Typ 590... .6  
Typ 590... .8  
Typ 590... .10**

Hochleistungsscheibenfräser

high performance  
disk-milling cutter

b = 6 / 8 / 10 mm ... **443**

**Typ 591... .6**

Hochleistung Aufsteck-Scheibenfräser

high performance arbour mounted  
disk-milling cutter

b = 6 mm ... **444**



**Fräswendeschneidplatten**

**indexable milling inserts**

**Maße  
dimensions**

**Seite  
page**

**Typ R/L 514**

Fräswendeschneidplatten:  
für Hochleistungsscheibenfräser  
Typ 590... .6 / Typ 591... .6  
Typ 590... .8 / Typ 591... .8  
Typ 590... .10 / Typ 591... .10

indexable milling inserts:  
for high performance  
disk-milling cutter  
Typ 590... .6 / Typ 591... .6  
Typ 590... .8 / Typ 591... .8  
Typ 590... .10 / Typ 591... .10

b = 6 / 8 / 10 mm ... **445**



## SYSTEM 500

Nut- und Trennfräsen

groove milling  
and slotting cutter

## Übersicht

summary

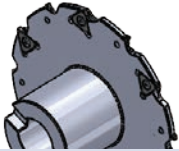

**Hochleistungstrennfräser  
mit Wendeschneidplatten  
Breite 3 / 4 / 5 mm**

**high performance  
slotting cutter  
with indexable inserts  
width 3 / 4 / 5 mm**

**Maße  
dimensions**

**Seite  
page**

Typ 590... .3  
Typ 590... .4  
Typ 590... .5

Hochleistungstrennfräser

high performance  
slotting cutter

b = 3 / 4 / 5 mm ... 446

Typ 591... .3

Hochleistungs Aufsteck-Trennfräser

high performance arbour mounted  
slotting cutter

b = 3 mm ... 447

Typ 591... .4

Hochleistungs Aufsteck-Trennfräser

high performance arbour mounted  
slotting cutter

b = 4 mm ... 448

Typ 591... .5

Hochleistungs Aufsteck-Trennfräser

high performance arbour mounted  
slotting cutter

b = 5 mm ... 449

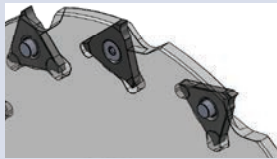

**Fräswendeschneidplatten**

**indexable milling inserts**

**Maße  
dimensions**

**Seite  
page**

Typ R/L 510

Fräswendeschneidplatten:  
für Hochleistungs (Aufsteck)-  
Trennfräser

Typ 590... .3 / Typ 591... .3  
Typ 590... .4 / Typ 591... .4  
Typ 590... .5 / Typ 591... .5

indexable milling inserts:  
for high performance  
(arbour mounted) slotting cutter  
Typ 590... .3 / Typ 591... .3  
Typ 590... .4 / Typ 591... .4  
Typ 590... .5 / Typ 591... .5

b = 3 / 4 / 5 mm ... 450

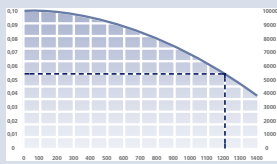

**Technische Hinweise**

**Technical Instructions**

**Seite  
page**

Grundsätzliche Informationen  
zum Gewindefräsen

basic informations about  
thread milling

... 451

Hartmetallsorten und  
Beschichtungen

Carbide grades and coatings

...453

Ermittlung der Schnittdaten

evaluation of the cutting data

...455

Schnittdaten

cutting data

... 457

## SYSTEM 500

Nut- und Trennfräsen

groove milling  
and slotting cutter

## Allgemeine Beschreibung

general instruction

Sehr scharf geschliffene dreischneidige Wendschneidplatten garantieren beste Ergebnisse auch bei hochfesten Materialien.

extremely sharp grinded inserts with three-cutting edges guarantees best results, even at high-strength materials.

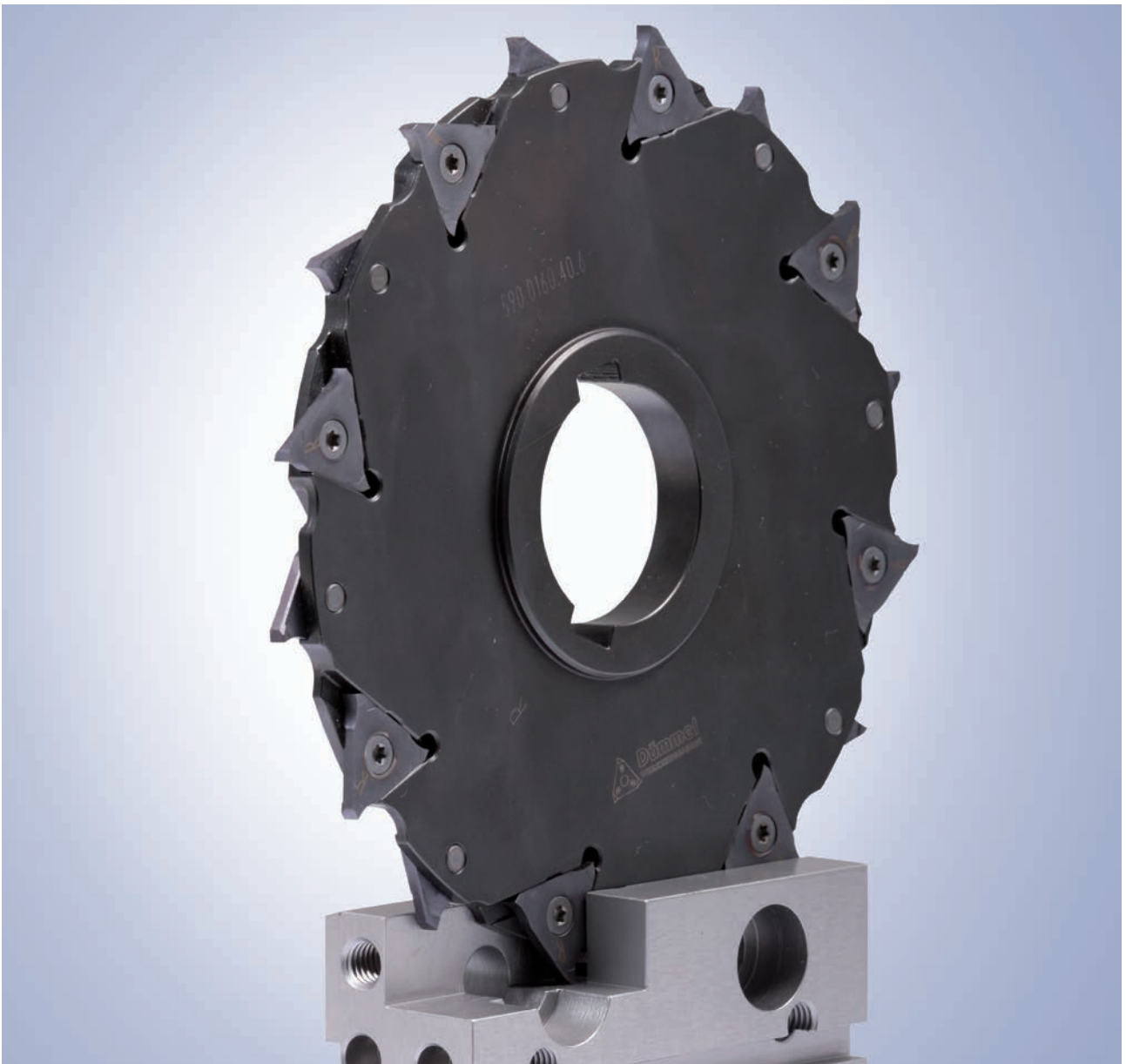



## SYSTEM 500

Nut- und Trennfräsen

groove milling  
and slotting cutter

## Typ 500.44.3

Frälerschaft

D min. 45 mm  
t max. 4.0

milling shank

D min. 45 mm  
t max. 4.0

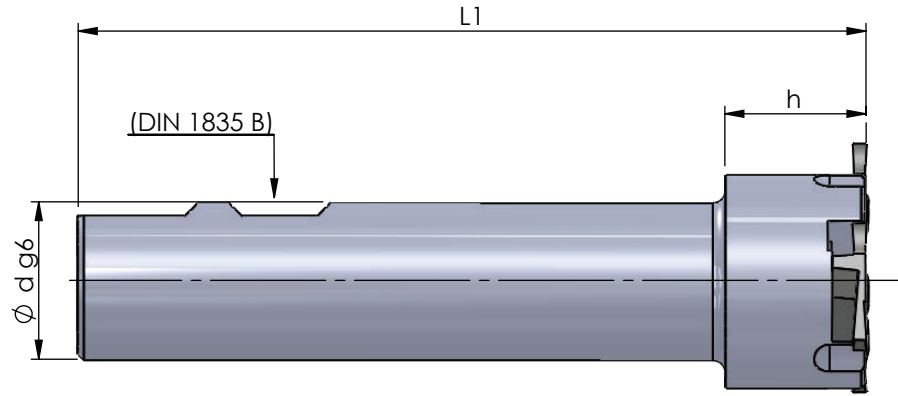
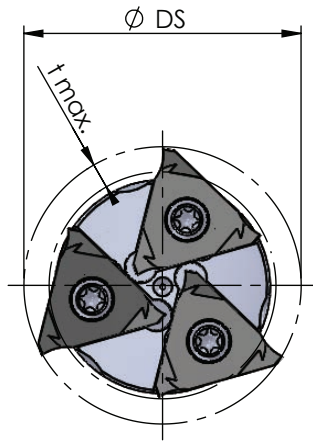

Abmessungen in mm

dimensions in mm

Bestellnummer part number	Ø DS	Ø d g6	t max.	L1	h	Schneidenzahl number of cutting edges	Spannschraube screw	Schraubenschlüssel wrench	Anzugs- drehmoment torque	für Schneidplatten for insert
500.44.3	44	25	4	125	22.4	3	85.818	TX-20/80	3.0 Nm	514....

Achtung:  
Frälerschaft ist ohne Schneidplatten!

Bestellbeispiel:  
500.44.3

attention:  
Milling shank is without inserts!

order-example:  
500.44.3



# SYSTEM 500

Nut- und Trennfräsen

groove milling  
and slotting cutter

# Typ 510.0063.05-D

Messerkopf

milling cutter

D min. 64 mm  
t max. 5.0

D min. 64 mm  
t max. 5.0

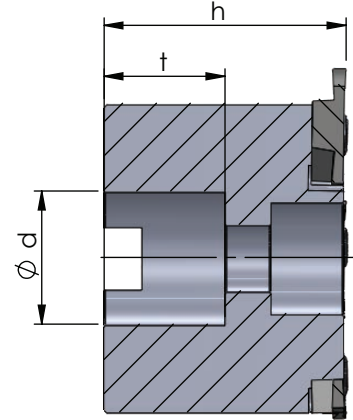
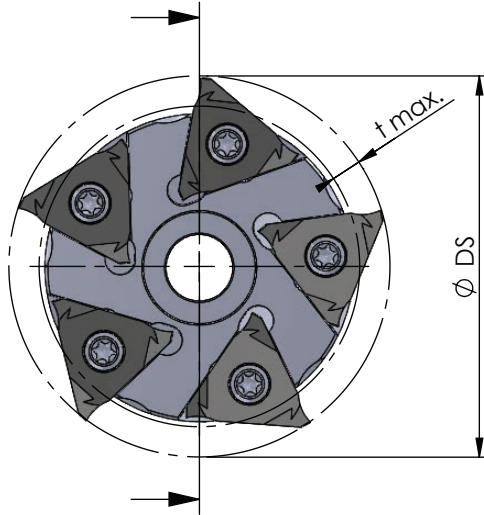

Abmessungen in mm

dimensions in mm



Bestellnummer part number	Ø DS	Ø d x t	t max.	h	Schneidenzahl number of cutting edges	Spannschraube screw	Schraubenschlüssel wrench	Anzugs- drehmoment torque	für Schneidplatten for insert
510.0063.05-D	63	Ø22 x 20	5	40	5	85.818	TX-20/80	3.0 Nm	514....

Achtung:  
Messerkopf ist ohne Schneidplatten!

Bestellbeispiel:  
510.0063.05-D

attention:  
Milling cutter is without inserts!

order-example:  
510.0063.05-D



**SYSTEM 500**

Nut- und Trennfräsen

groove milling  
and slotting cutter

**Typ 510.0080.08-D**

Messerkopf

D min. 81 mm  
t max. 5.0

milling cutter

D min. 81 mm  
t max. 5.0

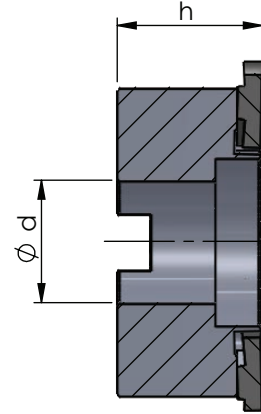
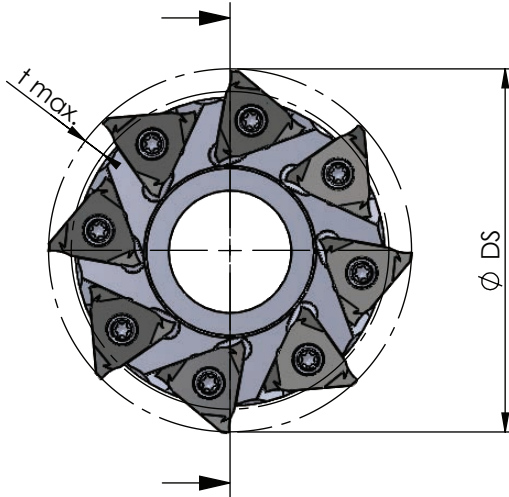

Abmessungen in mm

dimensions in mm

Bestellnummer part number	Ø DS	Ø d	t max.	h	Schneidenzahl number of cutting edges	Spannschraube screw	Schraubenschlüssel wrench	Anzugs- drehmoment torque	für Schneidplatten for insert
510.0080.08-D	80	27	5	32	8	85.818	TX-20/80	3.0 Nm	514....

Achtung:  
Messerkopf ist ohne Schneidplatten!

Bestellbeispiel:  
510.0080.08-D

attention:  
Milling cutter is without inserts!

order-example:  
510.0080.08-D



# SYSTEM 500

Nut- und Trennfräsen

groove milling  
and slotting cutter

# Typ 581

Messerkopf

milling cutter

D min. 64 mm  
t max. 5.0

D min. 64 mm  
t max. 5.0

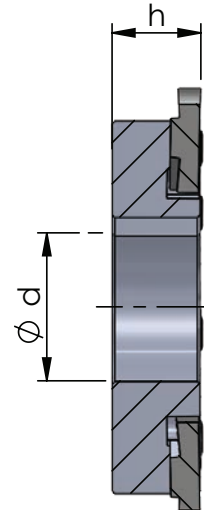
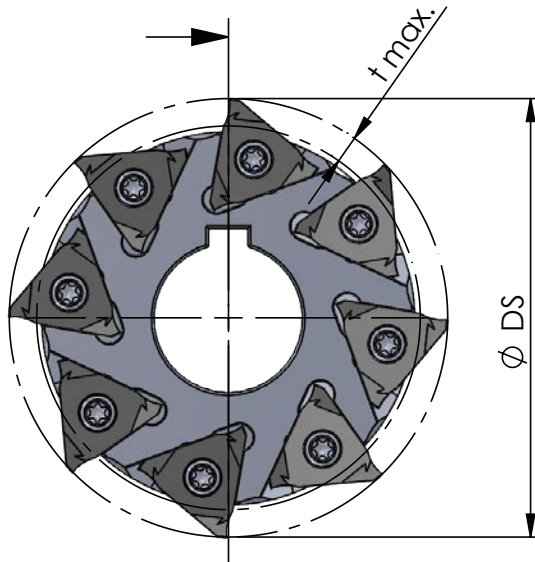

Abmessungen in mm

dimensions in mm

Bestellnummer part number	Ø DS	Ø d	t max.	h	Schneidenzahl number of cutting edges	Spannschraube screw	Schraubenschlüssel wrench	Anzugs- drehmoment torque	für Schneidplatten for insert
581.0063.05-D	63	22	5	14.2	5				
581.0080.08-D	80	27	5	16.2	8	85.818	TX-20/80	3.0 Nm	514....
581.0100.10-D	100	32	5	20.2	10				

Achtung:  
Messerkopf ist ohne Schneidplatten!

Bestellbeispiel:  
581.0063.05-D

attention:  
Milling cutter is without inserts!

order-example:  
581.0063.05-D



## SYSTEM 500

Nut- und Trennfräsen

groove milling  
and slotting cutter

## Typ 514

Fräswendeschneidplatte,  
für Sicherungsringe DIN 471 / 472

indexable milling insert,  
for circlip groove DIN 471 / 472

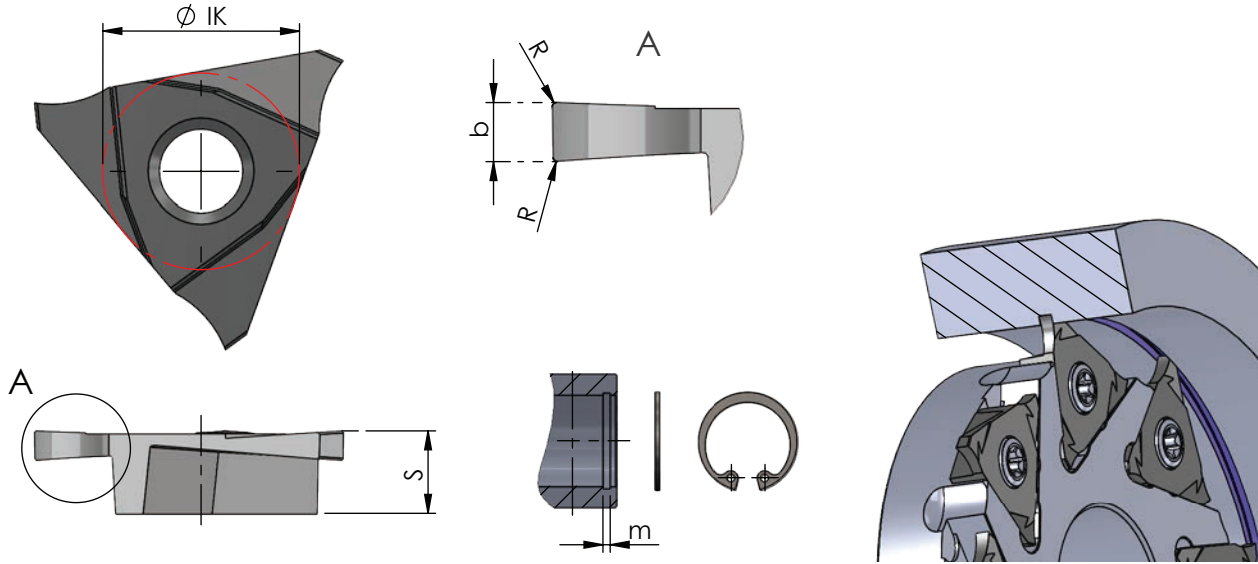

Abmessungen in mm

dimensions in mm

Bestellnummer part number	Nut-Maß m groove dim. m DIN 471 / DIN 472		S	b -0.02	R	Ø IK -0.03	K10F	AL41F	CN45F	für Fräferschaft / Messerkopf for milling shank / milling cutter
514.0130.00	1.3	☉	5.4	1.41	0.1	13	●	●	●	500... 510... 581...
514.0160.00	1.6	☉	5.4	1.71	0.15	13	●	●	●	
514.0185.00	1.85	☉	5.4	1.96	0.15	13	●	●	●	
514.0215.00	2.15	☉	5.4	2.26	0.15	13	●	●	●	
514.0265.00	2.65	☉	5.4	2.76	0.15	13	●	●	●	
514.0315.00	3.15	☉	5.4	3.26	0.15	13	●	●	●	
514.0415.00	4.15	☉	5.4	4.26	0.15	13	●	●	●	
514.0515.00	5.15	☉	5.4	5.26	0.15	13	●	●	●	

Weitere HM Sorten können Sie in der Sortenübersicht im Kapitel "Technische Hinweise" und der Preisliste finden.

Bestellbeispiel für Sorte AL41F:  
Rechts: 514.0130.00/AL41F  
Links: L514.0130.00/AL41F (auf Anfrage)

More carbide grades you can find in the grades summary in the chapter "technical instructions" and in the price list.

order-example grade AL41F:  
right: 514.0130.00/AL41F  
left: L514.0130.00/AL41F (on demand)

# SYSTEM 500

Nut- und Trennfräsen

groove milling  
and slotting cutter

# Typ 514

Fräswendeschnidplatte,  
für Sicherungsringe DIN 471 / 472,  
mit Nutaußenkantenfasung

indexable milling insert,  
for circlip groove DIN 471 / 472,  
with chamfer

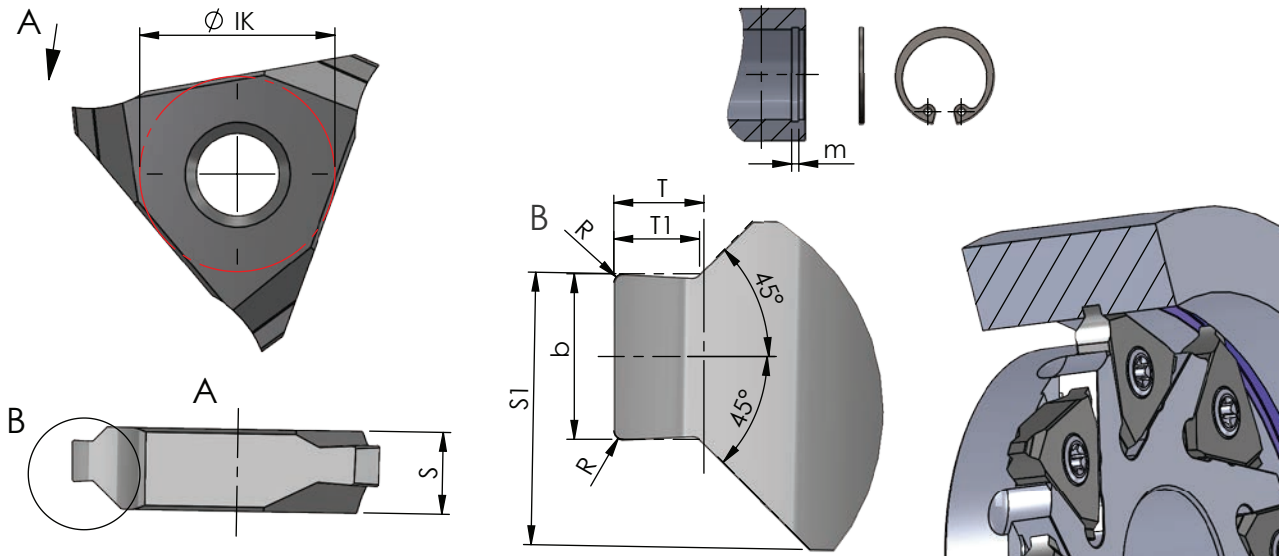

Abmessungen in mm

dimensions in mm



Bestellnummer part number	Nut-Maß m groove dim. m DIN 471 / DIN 472	S	S1 ±0.01	b -0.02	R	T1 -0.04 Formtiefe depth of form	T	Ø IK -0.03	K10F	AL41F	CN45F	für Fräseschaft / Messerkopf for milling shank / milling cutter
514.1105.35	1.1	5.4	4.52	1.21	0.1	0.49	0.50	13	●	●	●	500... 510... 581...
514.1307.35	1.3	5.4	4.62	1.41	0.1	0.67	0.70	13	●	●	●	
514.1308.35	1.3	5.4	4.62	1.41	0.1	0.83	0.85	13	●	●	●	
514.1609.35	1.6	5.4	4.52	1.71	0.15	0.83	0.85	13	●	●	●	
514.1610.35	1.6	5.4	4.52	1.71	0.15	0.97	1.00	13	●	●	●	
514.1812.35	1.85	5.4	4.64	1.96	0.15	1.23	1.25	13	●	●	●	
514.2115.43	2.15	5.4	4.79	2.26	0.15	1.47	1.50	13	●	●	●	
514.2616.43	2.65	5.4	4.54	2.76	0.15	1.47	1.50	13	●	●	●	
514.2617.43	2.65	5.4	4.54	2.76	0.15	1.72	1.75	13	●	●	●	
514.3118.53	3.15	5.4	4.79	3.26	0.15	1.72	1.75	13	●	●	●	
514.4120.53	4.15	5.4	4.99	4.26	0.15	1.97	2.00	13	●	●	●	
514.4125.53	4.15	5.4	4.99	4.26	0.15	2.47	2.50	13	●	●	●	
514.5130.61	5.15	6.1	5.85	5.26	0.15	2.97	3.00	13	●	●	●	

Weitere HM Sorten können Sie in der Sortenübersicht im Kapitel "Technische Hinweise" und der Preisliste finden.

Bestellbeispiel für Sorte AL41F:  
Rechts: 514.1105.35/AL41F  
Links: L514.1105.35/AL41F (auf Anfrage)

More carbide grades you can find in the grades summary in the chapter "technical instructions" and in the price list.

order-example grade AL41F:  
right: 514.1105.35/AL41F  
left: L514.1105.35/AL41F (on demand)

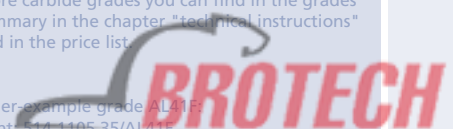

## SYSTEM 500

Nut- und Trennfräsen

groove milling  
and slotting cutter

## Typ 514

Fräswendeschnleidplatte,  
für metrisches ISO-Gewinde,  
Teilprofil, innen

indexable milling insert,  
metric ISO-thread,  
partial profile, internal

Steigung P = 1.5 - 6.0

pitch P = 1.5 - 6.0

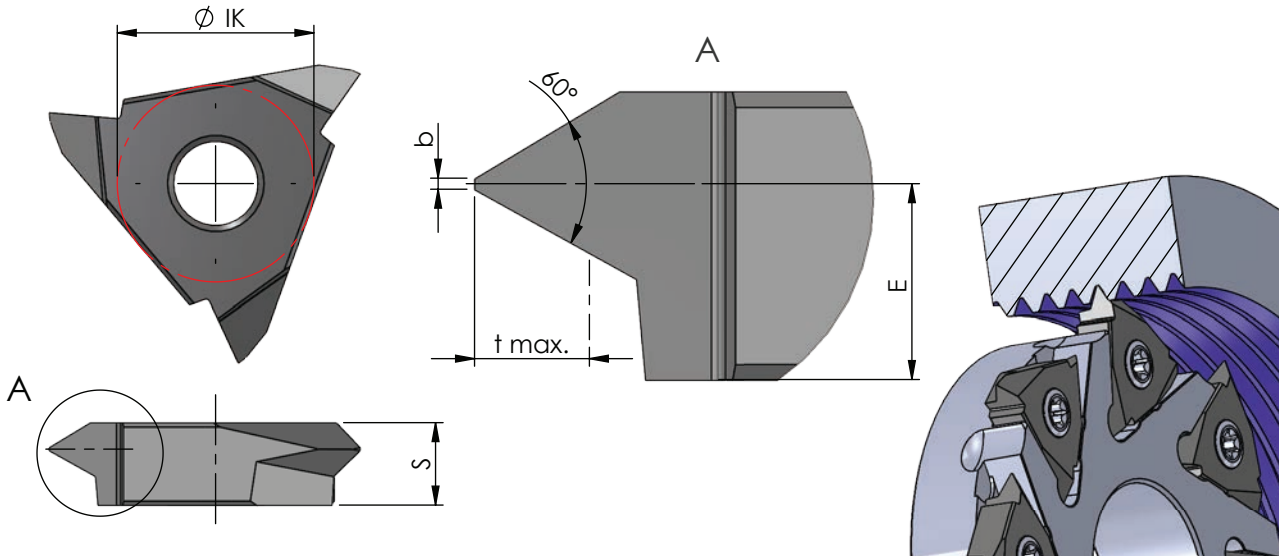

Abmessungen in mm

dimensions in mm

Bestellnummer part number	Steigung P pitch P	S	E	b	t max.	Ø IK -0.03	K10F	AL41F	P18C	für Fräseschaft / Messerkopf for milling shank / milling cutter
514.0815.01	1.5-1.5	5.4	4.60	0.19	0.81	13	●			
514.1020.01	2.0-2.0	5.4	4.40	0.25	1.08	13	●			
514.1535.01	1.5-3.5	5.4	3.90	0.18	1.89	13	●			
514.2140.01	3.5-4.0	5.4	3.70	0.43	2.17	13	●			500...
514.2445.01	3.75-4.5	5.4	3.40	0.47	2.44	13	●			510...
514.2750.01	4.0-5.0	5.4	3.35	0.50	2.70	13	●			581...
514.3260.01	4.5-6.0	5.4	3.00	0.56	3.25	13	●			
514.4060.01	3.5-6.0	5.4	3.00	0.44	3.52	13	●			

Weitere HM Sorten können Sie in der Sortenübersicht im Kapitel "Technische Hinweise" und der Preisliste finden.

Bestellbeispiel:  
für Sorte AL41F:  
514.0815.01/AL41F

More carbide grades you can find in the grades summary in the chapter "technical instructions" and in the price list.

order-example:  
grade AL41F:  
514.0815.01/AL41F

**BROTECH**

# SYSTEM 500

Nut- und Trennfräsen

groove milling  
and slotting cutter

# Typ 514

Fräswendeschnleidplatte,  
für metrisches ISO-Gewinde,  
Vollprofil, innen

indexable milling insert,  
metric ISO-thread,  
full profile, internal

Steigung P = 1.5 - 5.5

pitch P = 1.5 - 5.5

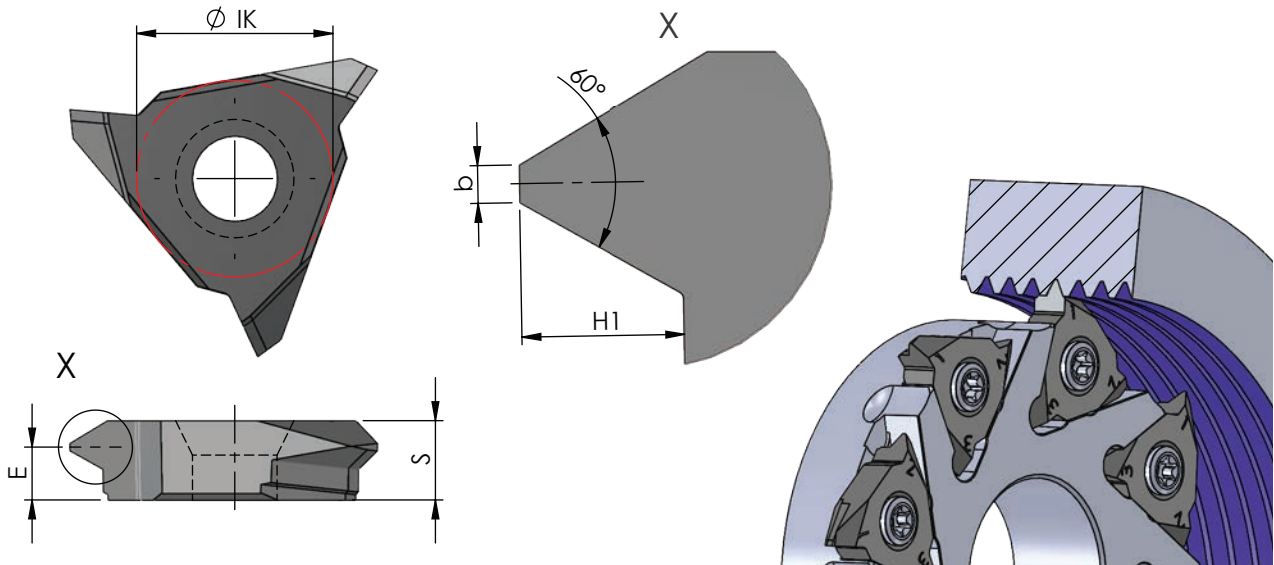

Abmessungen in mm

dimensions in mm



Bestellnummer part number	Steigung P pitch P	S	E	b	H1	Ø IK -0.03	K10F AL41F P18C	für Fräserchaft / Messerkopf for milling shank / milling cutter
514.0815.02	1.5	5.25	4.4	0.19	0.81	13	●	
514.1020.02	2.0	5.25	4.2	0.25	1.08	13	●	
514.1630.02	3.0	5.25	3.9	0.38	1.62	13	●	
514.1835.02	3.5	5.25	3.7	0.44	1.89	13	●	500...
514.2140.02	4.0	5.25	3.5	0.5	2.17	13	●	510...
514.2445.02	4.5	5.25	3.3	0.56	2.44	13	●	581...
514.2750.02	5.0	5.85	3.8	0.62	2.71	13	●	
514.2955.02	5.5	5.85	3.6	0.69	2.98	13	●	

Weitere HM Sorten können Sie in der Sortenübersicht im Kapitel "Technische Hinweise" und der Preisliste finden.

Bestellbeispiel:  
für Sorte AL41F:  
514.0815.02/AL41F

More carbide grades you can find in the grades summary in the chapter "technical instructions" and in the price list.

order-example:  
grade AL41F:  
514.0815.02/AL41F





# SYSTEM 500

Nut- und Trennfräsen

groove milling  
and slotting cutter

# Typ 590... .6 / .8 / .10

Hochleistungsscheibenfräser  
mit Bohrung und  
Längsnut nach DIN 138

high performance  
disk-milling cutter with bore  
and longitudinal keyway  
according DIN 138

Nutbreite b 6 / 8 / 10 mm  
Nuttiefe t max. 50 mm  
Schneidkreis-Ø Ds ab 80 mm

width of groove b 6 / 8 / 10 mm  
depth of groove t max. 50 mm  
cutting edge-Ø Ds starting at 80 mm

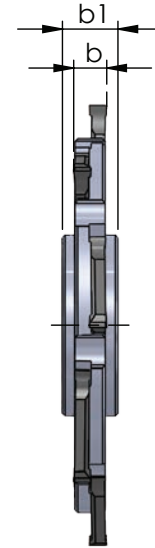
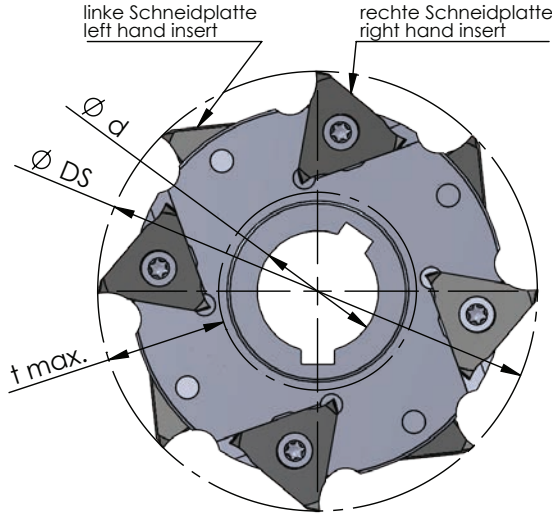

weitere Abmessungen auf  
Anfrage

further sizes upon request

Abmessungen in mm

dimensions in mm

Bestellnummer part number	Ø DS	Ø d	b	b1	t max.	Spannschraube screw	Schraubenschlüssel key driver	Anzugs- drehmoment torque	Anzahl Schneidplatten R/L number inserts R/L	Schneidplatte insert type
590.0080.22.6	80	22	6	10	22	5.06.25F	Tr15	2.0	4/4	R/L 514.0632.00
590.0080.27.6	80	27	6	10	21	5.06.25F	Tr15	2.0	4/4	R/L 514.0632.00
590.0080.27.8	80	27	8	12	21	5.08.25F	Tr20	2.8	4/4	R/L 514.0843.00
590.0080.27.10	80	27	10	12	21	5.10.25	Tr20	3.0	4/4	R/L 514.1054.00
590.0100.32.6	100	32	6	10	25.5	5.06.25F	Tr15	2.0	5/5	R/L 514.0632.00
590.0100.32.8	100	32	8	12	25.5	5.08.25F	Tr20	2.8	5/5	R/L 514.0843.00
590.0100.32.10	100	32	10	12	25.5	5.10.25	Tr20	3.0	5/5	R/L 514.1054.00
590.0125.40.6	125	40	6	10	32.5	5.06.25F	Tr15	2.0	6/6	R/L 514.0632.00
590.0125.40.8	125	40	8	12	32.5	5.08.25F	Tr20	2.8	6/6	R/L 514.0843.00
590.0125.40.10	125	40	10	14	32.5	5.10.25	Tr20	3.0	6/6	R/L 514.1054.00
590.0160.40.6	160	40	6	10	50	5.06.25F	Tr15	2.0	8/8	R/L 514.0632.00
590.0160.40.8	160	40	8	12	50	5.08.25F	Tr20	2.8	8/8	R/L 514.0843.00
590.0160.40.10	160	40	10	14	50	5.10.25	Tr20	3.0	8/8	R/L 514.1054.00

Achtung:  
Scheibenfräser ist ohne Schneidplatten!

attention:  
disk-milling cutter is without inserts!

Bestellbeispiel:  
590.0080.22.6

order-example:  
590.0080.22.6



# SYSTEM 500

Nut- und Trennfräsen

groove milling  
and slotting cutter

# Typ 591... .6

Hochleistungs  
Aufsteck-Scheibenfräser

high performance  
arbour mounted  
disk-milling cutter

Nutbreite b 6 mm  
Nuttiefe t max. 37.5 mm  
Schneidkreis-Ø Ds 125 mm

width of groove b 6 mm  
depth of groove t max. 37.5 mm  
cutting edge-Ø Ds 125 mm

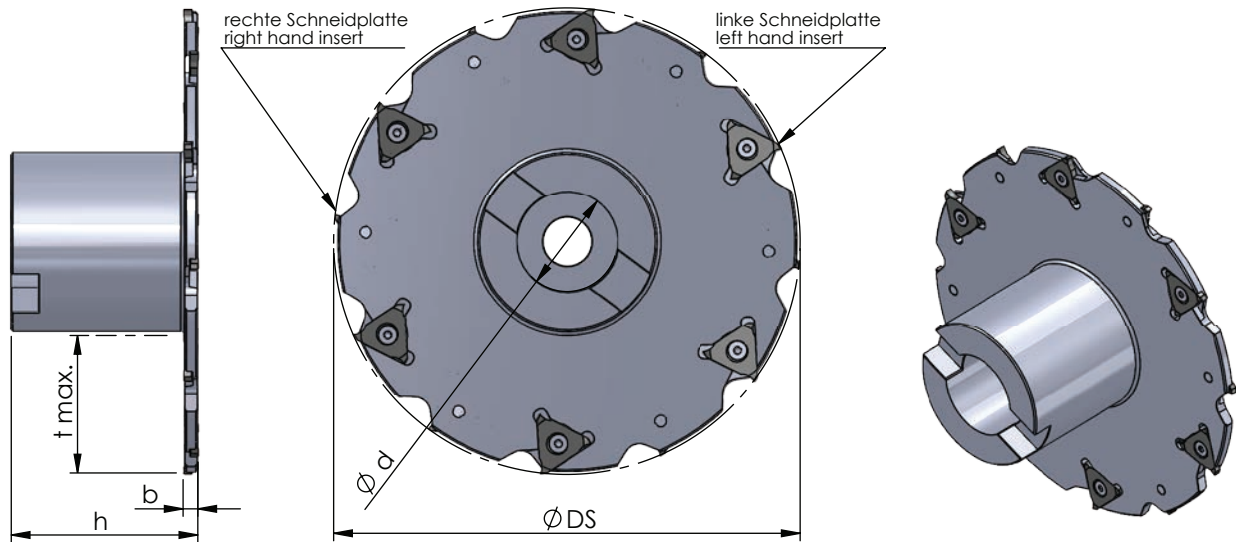

weitere Abmessungen auf  
Anfrage

further sizes upon request

Abmessungen in mm

dimensions in mm



Bestellnummer part number	Ø DS	Ø d	b	Ø d1	h	t max.	Befestigung/fixing			Anzahl Schneidplatten R/L number inserts R/L	Schneidplatte insert type		
							Spannschraube screw	Schraubenschlüssel wrench	Anzugs- drehmoment torque				
591.0125.27.6	125	27	6	48	50	37.5	5.06.25F	Tr15	2.0	DIN 912 M12x35	DIN 433- 13-2	6/6	R/L 514.0632.00

Achtung:  
Scheibenfräser ist ohne Schneidplatten!

attention:  
disk-milling cutter is without inserts!

Bestellbeispiel:  
591.0125.27.6

order-example:  
591.0125.27.6



# SYSTEM 500

Nut- und Trennfräsen

groove milling  
and slotting cutter

# Typ 514

Fräswendeschnidplatte

indexable milling insert

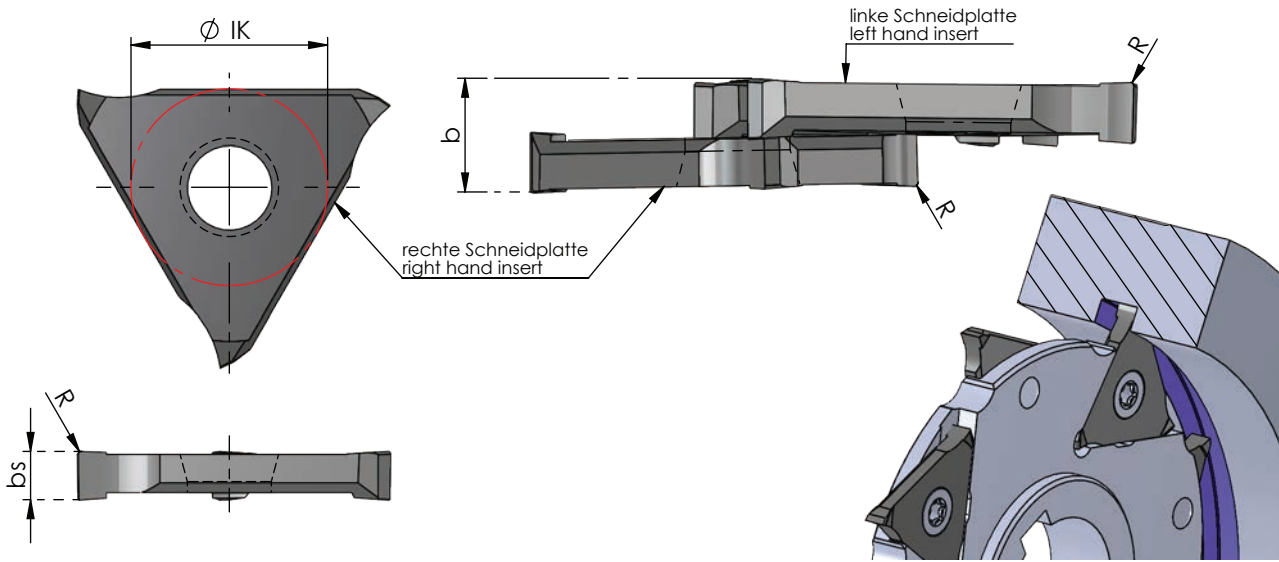

Rechts (R): wie gezeichnet  
Links (L): spiegelbildlich

righthand (R): as shown  
lefthand (L): mirror image

Abmessungen in mm

dimensions in mm

Bestellnummer part number	b für Nutbreite b width of groove	bs	R	Ø IK	K10F AL41F CN45F	für Scheibenfräser for disk milling cutter
R/L 514.0632.00	6	3.2	0.2	13	● ● ●	
R/L 514.0843.00	8	4.3	0.2	13	● ● ●	590,...
R/L 514.1054.00	10	5.4	0.2	13	● ● ●	591,...

Weitere HM Sorten können Sie in der Sortenübersicht im Kapitel "Technische Hinweise" und der Preisliste finden.

Bestellbeispiel:  
für rechte Ausführung und Sorte  
R514.0632.00/AL41F

More carbide grades you can find in the grades summary in the chapter "technical instructions" and in the price list.

order-example:  
righthand version and grade  
R514.0632.00/AL41F

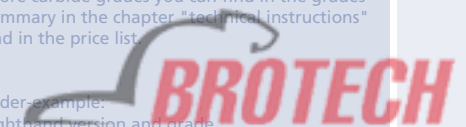

# SYSTEM 500

Nut- und Trennfräsen

groove milling  
and slotting cutter

# Typ 590... .3 / .4 / .5

Hochleistungstrennfräser  
mit Bohrung und  
Längsnut nach DIN 138

high performance  
slotting cutter with bore  
and longitudinal keyway  
according DIN 138

Nutbreite b 3 / 4 / 5 mm  
Nuttiefe t max. 50 mm  
Schneidkreis-Ø Ds ab 80 mm

width of groove b 3 / 4 / 5 mm  
depth of groove t max. 50 mm  
cutting edge-Ø Ds starting at 80 mm

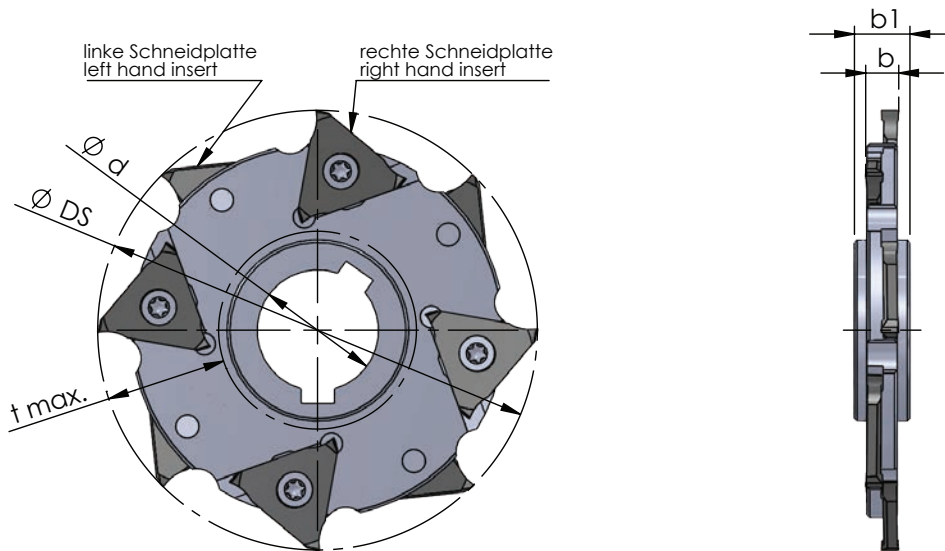

weitere Abmessungen auf  
Anfrage

further sizes upon request

Abmessungen in mm

dimensions in mm

Bestellnummer part number	Ø DS	Ø d	b	b1	t max.	Spannschraube screw	Schraubenschlüssel key driver	Anzugs- drehmoment torque	Anzahl Schneidplatten R/L number inserts R/L	Schneidplatte insert type
590.0080.27.3	80	27	3	8	18	025.03F	DSD-TX7/07	0.7	4/4	R/L 510.0317
590.0100.32.3	100	32	3	8	25	025.03F	DSD-TX7/07	0.7	5/5	R/L 510.0317
590.0125.40.3	125	40	3	10	32	025.03F	DSD-TX7/07	0.7	6/6	R/L 510.0317
590.0160.40.3	160	40	3	10	50	025.03F	DSD-TX7/07	0.7	8/8	R/L 510.0317
590.0080.27.4	80	27	4	8	18	035.04F	TR8	1.3	4/4	R/L 510.0423
590.0100.32.4	100	32	4	8	25	035.04F	TR8	1.3	5/5	R/L 510.0423
590.0125.40.4	125	40	4	10	32	035.04F	TR8	1.3	6/6	R/L 510.0423
590.0160.40.4	160	40	4	10	50	035.04F	TR8	1.3	8/8	R/L 510.0423
590.0080.27.5	80	27	5	8	18	035.05F	TR8	1.3	4/4	R/L 510.0528
590.0100.32.5	100	32	5	8	25	035.05F	TR8	1.3	5/5	R/L 510.0528
590.0125.40.5	125	40	5	10	32	035.05F	TR8	1.3	6/6	R/L 510.0528
590.0160.40.5	160	40	5	10	50	035.05F	TR8	1.3	8/8	R/L 510.0528

Achtung:  
Trennfräser ist ohne Schneidplatten!

attention:  
slotting cutter is without inserts!

Bestellbeispiel:  
590.0080.27.3

order-example:  
590.0080.27.3



## SYSTEM 500

Nut- und Trennfräsen

groove milling  
and slotting cutter

## Typ 591... .3

Hochleistungs Aufsteck-Trennfräser  
mit Bohrung und  
Quernut nach DIN 138

high performance arbour mounted  
slotting cutter with bore and cross  
keyway according DIN 138

Nutbreite b 3 mm  
Nuttiefe t max. 44 mm  
Schneidkreis-Ø Ds ab 63 mm

width of groove b 3 mm  
depth of groove t max. 44 mm  
cutting edge-Ø Ds starting at 63 mm

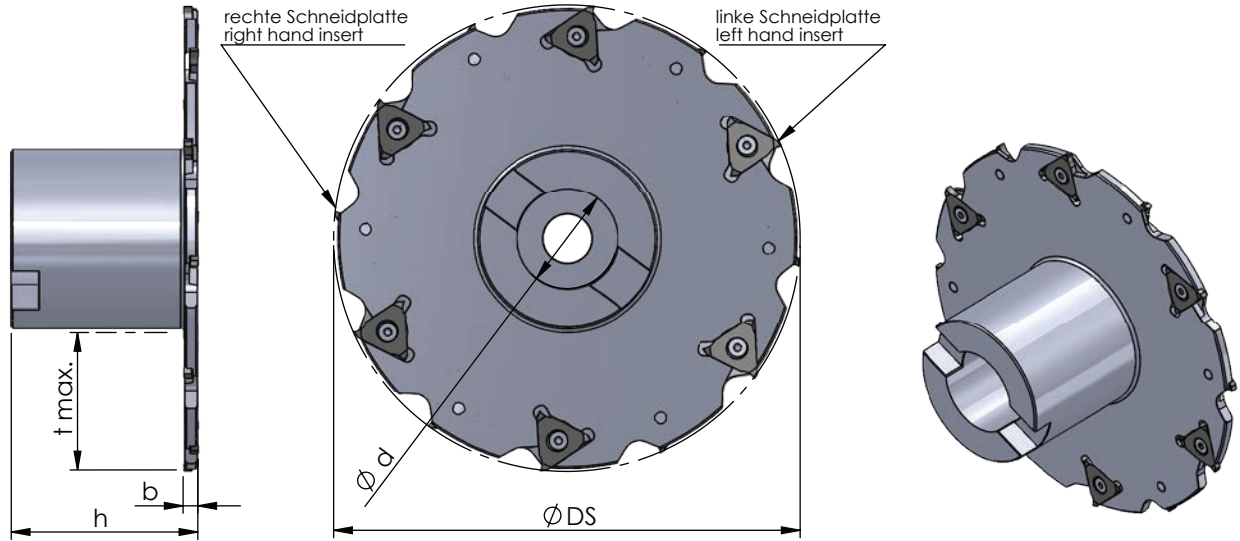

weitere Abmessungen auf  
Anfrage

further sizes upon request

Abmessungen in mm

dimensions in mm

Bestellnummer part number	Ø DS	Ø d	b	Ø d1	h	t max.	Spannschraube screw	Schraubenschlüssel wrench	Anzugs- drehmoment torque	Befestigung/fixing		Anzahl Schneidplatten R/L number inserts R/L	Schneidplatte insert type
										Spannschraube screw	Unterleg- scheibe washer		
591.0063.16.3	63	16	3	27	50	17.5	025.03F	DSD- TX7/07	0.7 Nm	DIN 912-	DIN125-	4/4	R/L 510.0317
591.0080.16.3	80	16	3	28	50	25				M8 x 40	8.4/5	4/4	
591.0100.27.3	100	27	3	48	50	25				DIN 912-	DIN433-	5/5	
591.0125.27.3	125	27	3	48	50	37.5				M12 x 35	13-2	6/6	
591.0160.40.3	160	40	3	70	50	44				M20 x 40	DIN433- 21-3	8/8	

Achtung:  
Trennfräser ist ohne Schneidplatten!

attention:  
slotting cutter is without inserts!

Bestellbeispiel:  
591.0063.16.3

order-example:  
591.0063.16.3



# SYSTEM 500

Nut- und Trennfräsen

groove milling  
and slotting cutter

# Typ 591... .4

Hochleistungs Aufsteck-Trennfräser  
mit Bohrung und  
Quernut nach DIN 138

high performance arbour mounted  
slotting cutter with bore and cross  
keyway according DIN 138

Nutbreite b 4 mm  
Nuttiefe t max. 64 mm  
Schneidkreis-Ø Ds ab 63 mm

width of groove b 4 mm  
depth of groove t max. 64 mm  
cutting edge-Ø Ds starting at 63 mm

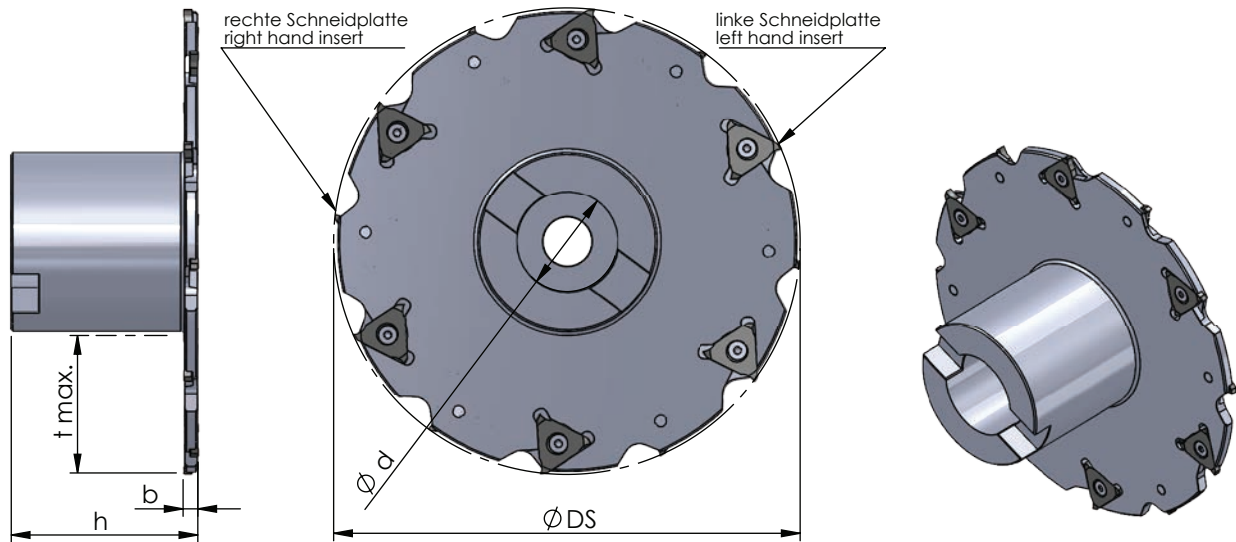

weitere Abmessungen auf  
Anfrage

further sizes upon request

Abmessungen in mm

dimensions in mm



Bestellnummer part number	Ø DS	Ø d	b	Ø d1	h	t max.	Spannschraube screw	Schraubenschlüssel wrench	Anzugs- drehmoment torque	Befestigung/fixing		Anzahl Schneidplatten R/L number inserts R/L	Schneidplatte insert type
										Spannschraube screw	Unterleg- scheibe washer		
591.0063.16.4	63	16	4	27	50	17.5	035.04F	TR8	1.3 Nm	DIN 912- M8 x 40	DIN125- 8.4/5	4/4	R/L 510.0423
591.0080.16.4	80	16	4	28	50	25				DIN 912- M12 x 35	DIN433- 13-2	5/5	
591.0100.27.4	100	27	4	48	50	25				DIN 912- M20 x 40	DIN433- 21-3	6/6	
591.0125.27.4	125	27	4	48	50	37.5				DIN 912- M12 x 35	DIN433- 13-2	6/6	
591.0125.40.4	125	40	4	70	50	26.5				DIN 912- M20 x 40	DIN433- 21-3	6/6	
591.0160.27.4	160	27	4	48	50	55				DIN 912- M12 x 35	DIN433- 13-2	8/8	
591.0160.40.4	160	40	4	70	50	44				DIN 912- M20 x 40	DIN433- 21-3	8/8	
591.0180.40.4	180	40	4	70	50	54				DIN 912- M20 x 40	DIN433- 21-3	9/9	
591.0200.40.4	200	40	4	70	50	64				DIN 912- M20 x 40	DIN433- 21-3	10/10	

Achtung:  
Trennfräser ist ohne Schneidplatten!

attention:  
slotting cutter is without inserts!

Bestellbeispiel:  
591.0063.16.4

order-example:  
591.0063.16.4



# SYSTEM 500

Nut- und Trennfräsen

groove milling  
and slotting cutter

## Typ 591... .5

Hochleistungs Aufsteck-Trennfräser  
mit Bohrung und  
Quernut nach DIN 138

high performance arbour mounted  
slotting cutter with bore and cross  
keyway according DIN 138

Nutbreite b 5 mm  
Nuttiefe t max. 37.5 mm  
Schneidkreis-Ø Ds ab 100 mm

width of groove b 5 mm  
depth of groove t max. 37.5 mm  
cutting edge-Ø Ds starting at 100 mm

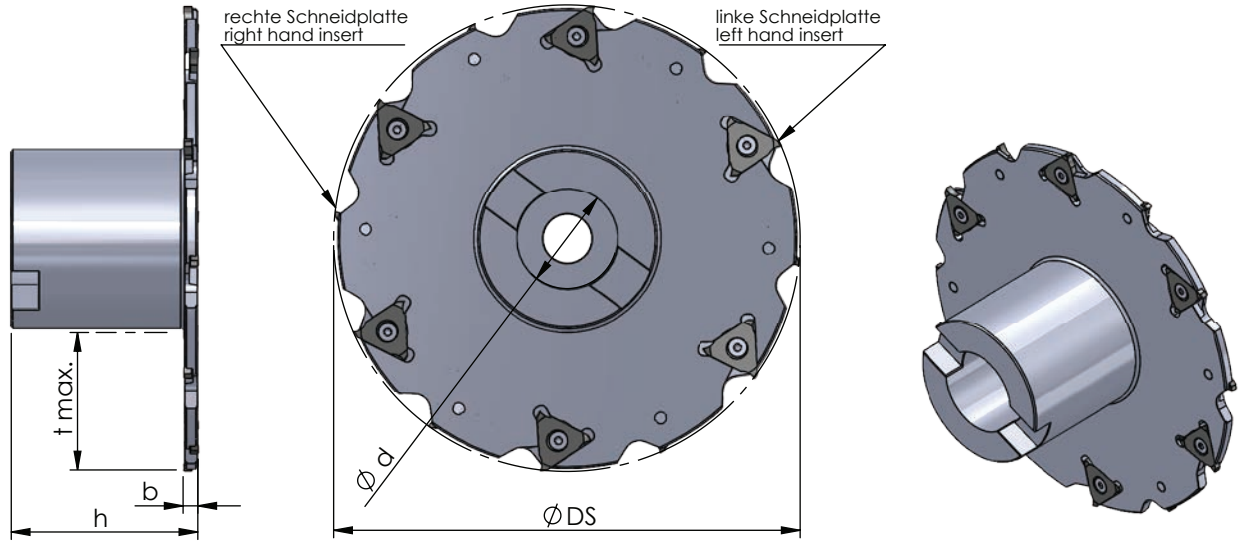

weitere Abmessungen auf  
Anfrage

further sizes upon request

Abmessungen in mm

dimensions in mm

Bestellnummer part number	Ø DS	Ø d	b	Ø d1	h	t max.	Befestigung/fixing			Anzahl Schneidplatten R/L number inserts R/L	Schneidplatte insert type		
							Spannschraube screw	Schraubenschlüssel wrench	Anzugs- drehmoment torque				
591.0100.27.5	100	27	5	48	50	25	035.05F	TR8	1.3 Nm	DIN 912- M12 x 35	DIN433- 13-2	5/5	R/L 510.0528
591.0125.27.5	125	27	5	48	50	37.5	035.05F	TR8	1.3 Nm			6/6	R/L 510.0528

Achtung:  
Trennfräser ist ohne Schneidplatten!

attention:  
slotting cutter is without inserts!

Bestellbeispiel:  
591.0100.27.5

order-example:  
591.0100.27.5



# SYSTEM 500

Nut- und Trennfräsen

groove milling  
and slotting cutter

# Typ R/L 510

Fräswendeschnidplatte

indexable milling inset

für Trennfräser Typ 590 und  
Aufsteck-Trennfräser Typ 591

for slotting cutter type 590 and  
arbor mounted slotting cutter  
type 591

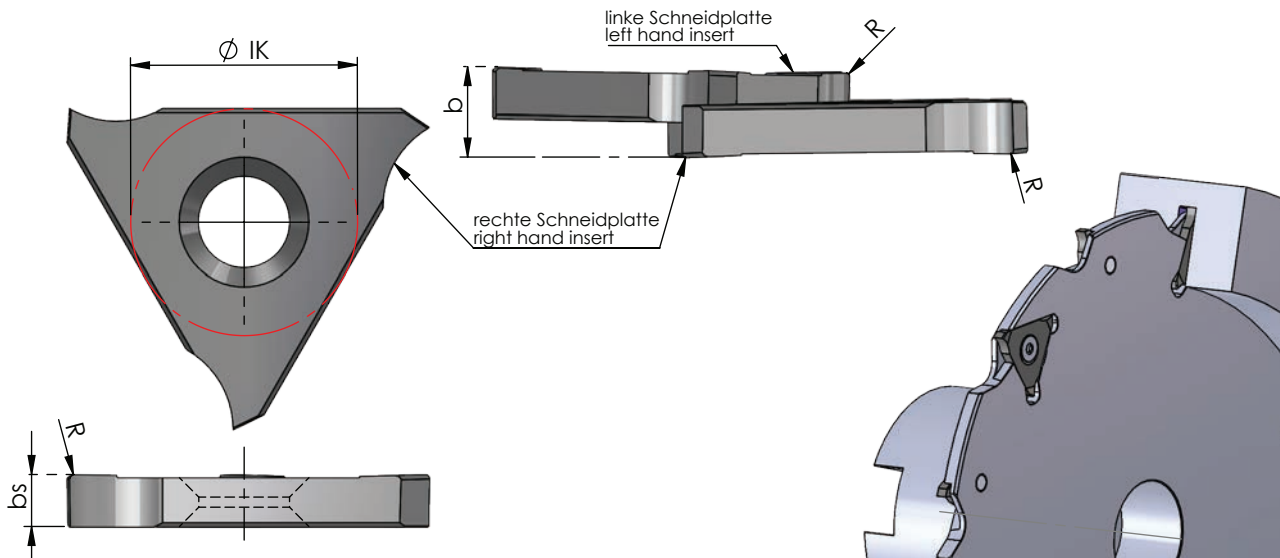

Rechts (R): wie gezeichnet  
Links (L): spiegelbildlich

righthand (R): as shown  
lefthand (L): mirror image

Abmessungen in mm

dimensions in mm

Bestellnummer part number	b für Nutbreite b width of groove	bs	R	Ø IK	Material			für Trennfräser for slotting cutter
					K10F	AL41F	P18C	
R/L 510.0317	3	1.7	0.15	10	●	●		590.....3 591.....3
R/L 510.0423	4	2.3	0.2	10	●	●		590.....4 591.....4
R/L 510.0528	5	2.8	0.2	10	●	●		590.....5 591.....5

Weitere HM Sorten können Sie in der Sortenübersicht im Kapitel "Technische Hinweise" und der Preisliste finden.

Bestellbeispiel:  
für Sorte AL41F:  
R510.0317/AL41F

More carbide grades you can find in the grades summary in the chapter "technical instructions" and in the price list.

order example:  
grade AL41F:  
R510.0317/AL41F



## SYSTEM 500

Nut- und Trennfräsen

groove milling  
and slotting cutter

## Technische Hinweise

Grundsätzliche Informationen zum Gewindefräsen

Technical instructions,  
basic informations about thread milling

### Vor- und Nachschnitt

Beim Zirkularfräsen von Gewinden entsteht durch die Steigung ein Vor- und Nachschnitt. Um hier die Verletzung des Gewindeprofils so gering wie möglich zu halten muß ein Werkzeug mit einem möglichst kleinen Schneidkreis gewählt werden. Die nachfolgende Skizze zeigt die Verhältnisse bei der Bearbeitung:  
(Grün: Konturverletzung X gering = gut; Rot: Konturverletzung X erheblich = schlecht)

#### Thread profile violation

Thread milling by interpolation causes a profile violation. To keep the violation minimal you should use the cutting circle as small as possible.

The following sketch shows the relations during the process:

(green: profile violation X low = good; red: profile violation X big = bad)

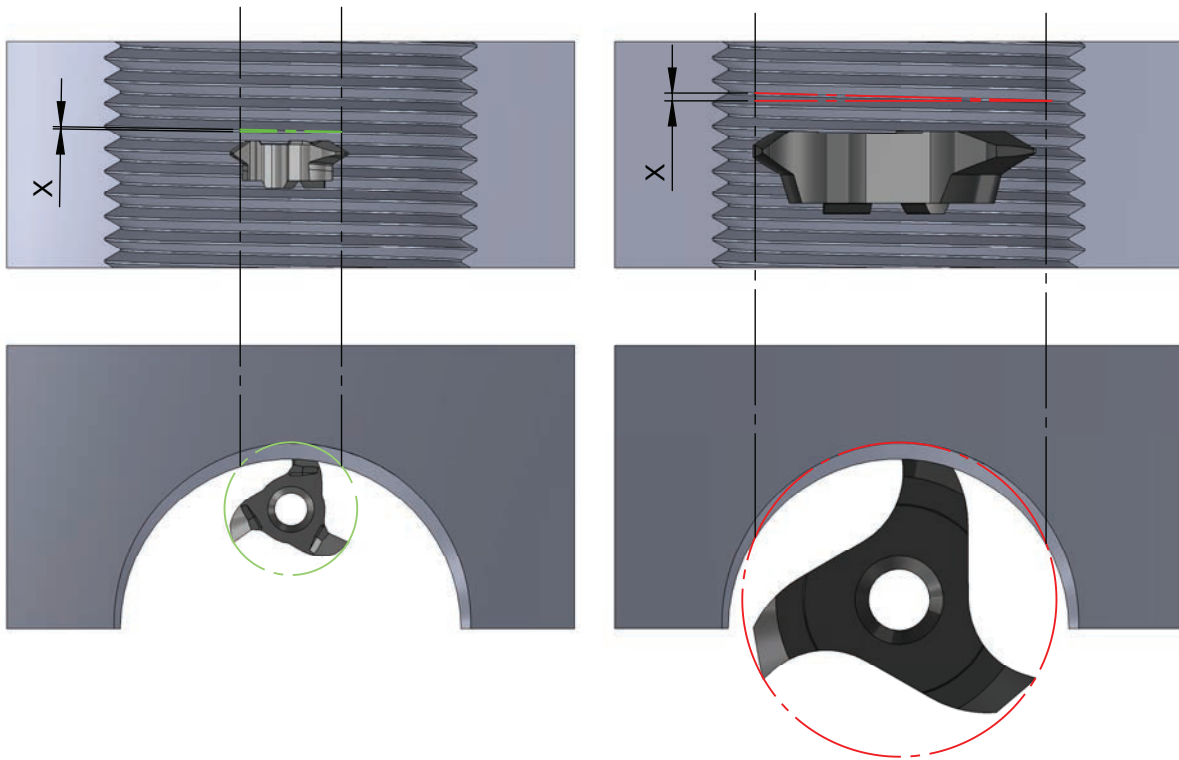

## SYSTEM 500

Nut- und Trennfräsen

groove milling  
and slotting cutter

## Technische Hinweise

Grundsätzliche Informationen zum Gewindefräsen

Technical instructions,  
basic informations about thread milling

### Teilprofil

Werkzeuge mit Teilprofil sind Mehrbereichswerkzeuge, d.h. mit diesem Werkzeug können Gewinde mit unterschiedlichen Steigungen hergestellt werden. Dies ist aber nur mit einer kleinen Abweichung vom Normprofil möglich. Abgestimmt ist das Werkzeug auf die kleinste angegebene Steigung, dieses Profil kann ohne Abweichung produziert werden. Alle weiteren Steigungen können ebenfalls produziert werden, hier weicht aber das gefertigte Profil gegenüber der Norm durch eine höhere Gewindetiefe ab. In der Regel ist dies unproblematisch, muß aber gegebenenfalls im Einzelfall genauer betrachtet werden.

#### Partial profile

Tools with partial profile are multi-purpose tools, that means you can process several pitches with one tool. The processed shape has a small difference to the standard profile. Created is that tool for the smallest pitch, this profile depends to the standard.

All other pitches are producible, but only with a small deviation. Normally this causes no problem, but sometimes you have to decide case by case.

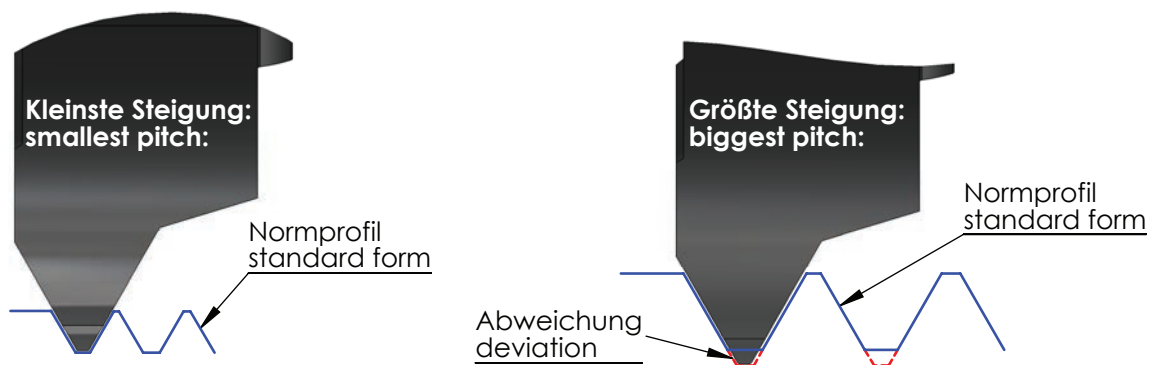

## SYSTEM 500

Nut- und Trennfräsen

groove milling  
and slotting cutter

## Technische Hinweise

Hartmetallsorten und Beschichtungen

Technical instructions,  
carbide grades and coatings

### K10F

Universell einsetzbares Feinkornhartmetall mit guter Verschleißfestigkeit. Unbeschichtet geeignet für Anwendungen mit niedrigen und mittleren Schnittgeschwindigkeiten, sowie die Bearbeitung von Nicht-eisenmetallen.

All purpose micrograin carbide with good abrasion resistance. Uncoated for applications with low or medium cutting speeds and machining of non-ferrous materials.

### CBN

Zähe CBN-Sorte für Anwendungen mit niedrigen Schnittgeschwindigkeiten. Geeignet für gehärtete Stähle, unterbrochene Schnitte und Grauguss.

Ductile CBN grade for applications with lower cutting speed. Suitable for hardened steel, interrupted cuts and cast iron.

### CN45F

Universell einsetzbare PVD-TiN-Beschichtung. Diese Allround-Sorte ist für niedrige und mittlere Schnittgeschwindigkeiten mit Einschränkung bei NE-Metallen

PVD-TiN coating - all purpose, all around grade is suitable for low and medium cutting speed with restrictions on non-ferrous materials.

### AL41F

Sehr universell einsetzbare TiAlN-Beschichtung mit hoher Temperaturbeständigkeit bei hoher Härte. Sehr gut geeignet auch für NE-Metalle.

TiAlN coating - very universal with a high resistance to high temperature and hardness. Very suitable also for non-ferrous metals.

### PD2F

Beschichtung für den universellen Einsatz bei niedrigen und mittleren Schnittgeschwindigkeiten.

Coating for universal use with medium and low speed.

### XC2A

Beschichtung mit einer excellenten Warmhärte, Oxidationsbeständigkeit und thermischen Isolationsfähigkeit. Ideal für Hartzerspannung >60HRC

Coating with excellent hot hardness, high oxidation resistance and thermal insulation capacity. Perfect for hard machining >60 HRC.

## SYSTEM 500

Nut- und Trennfräsen

groove milling  
and slotting cutter

## Technische Hinweise

Hartmetallsorten und Beschichtungen

Technical instructions,  
carbide grades and coatings

### P01C

Beschichtung für die Bearbeitung in zähen Materialien bei niedrigen und mittleren Schnittgeschwindigkeiten.

Coating for the processing in tough material with medium or low cutting speed

### P03C

Beschichtung für die Bearbeitung von schwer zerspanbaren Materialien. Sehr gut auch für die Trockenbearbeitung geeignet.

Coating for materials which are difficult to machine. Perfect to use for dry machining.

### P07C

Beschichtung für die Bearbeitung von Titan, Edelstahl und Molybdän.

Coating to machine titanium, stainless steel and molybdenum.

### P18C

Universell einsetzbare Hochleistungsschicht mit hoher Oxidationsbeständigkeit, Verschleißfestigkeit und Warmhärte.

Very universal high performance coating with high oxidation resistance, wear resistance and hot hardness resistance.

### NEME

Beschichtung für die Bearbeitung von Aluminium, Al-Legierungen, NE-Metallen und Composite-Werkstoffen.

Coating for machining aluminium, alloys, non-ferrous metals and composite materials.



## SYSTEM 500

Nut- und Trennfräsen

groove milling  
and slotting cutter

## Technische Hinweise

Ermittlung der Schnittdaten  
für das Zirkularfräsen

Technical instructions,  
evaluation of the cutting data for groove milling

Fräsen Außenkontur  
milling external

$$n = \frac{V_c \cdot 1000}{d \cdot \pi} \quad V_{\text{eff}} = f_z \cdot z \cdot n \quad f_z = h_m \sqrt{\frac{d}{a_e}}$$

$$V_{\text{prog}} = \frac{V_{\text{eff}} \cdot (D + d)}{D} \quad V_{\text{eff}} = \frac{D \cdot V_{\text{prog}}}{(D + d)}$$

Fräsen Innenkontur  
milling internal

$$V_{\text{prog}} = \frac{V_{\text{eff}} \cdot (D - d)}{D} \quad V_{\text{eff}} = \frac{D \cdot V_{\text{prog}}}{(D - d)}$$

Formel-Zeichen  
formula characters

Bezeichnungen  
specifications

Einheit  
unit

**d**

Fräserdurchmesser  
milling diameter

mm

**D**

Gewindedurchmesser  
thread diameter

mm

**V<sub>eff</sub>**

effektive Vorschubgeschwindigkeit  
(auf / an der Kontur)  
feed rate of tool tip

mm / min

**V<sub>eint</sub>**

programmierter Eintauchvorschub  
programmed plunge feed

mm / min

**V<sub>prog</sub>**

programmierte Vorschubgeschwindigkeit  
feed rate of tool center

mm / min

**z**

Schneidenzahl Fräser  
number of cutting edges

Stk.  
pcs.

Nach Möglichkeit immer im Kreisbogen  
eintauchen.

Always plunge in a circular arc where possible.

Beim geraden Eintauchen nur 1/3 des Vorschubs  
verwenden und erst beim Erreichen der Frästie-  
fe vollen Vorschub fahren.

When plunging straight use only 1/3 of the feed  
and do not traverse full feed until reaching the  
milling depth.

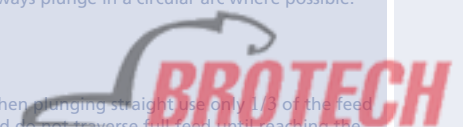

## SYSTEM 500

Nut- und Trennfräsen

groove milling  
and slotting cutter

## Technische Hinweise

Ermittlung der Schnittdaten  
für das Trennfräsen

Technical instructions,  
evaluation of the cutting data for groove milling  
and slotting cutter

$$z = \frac{\text{Fräswendeschnidplatten/} \\ \text{quantity of cutting inserts}}{2}$$

$$n = \frac{V_c \cdot 1000}{d \cdot \pi}$$

$$V_f = n \cdot z \cdot f_z \text{ mm/min}$$

$$f_z = h_m \sqrt{\frac{2r}{a_e}}$$

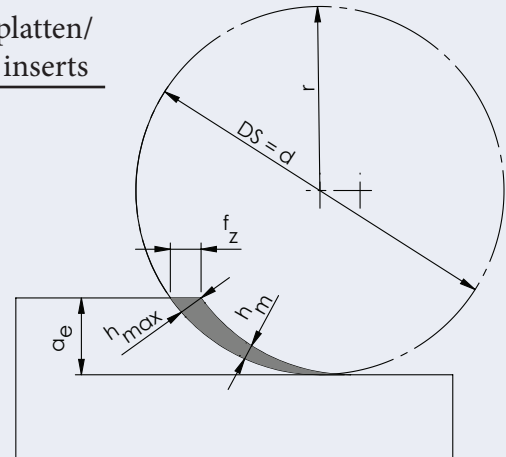

Formel-Zeichen  
formula characters

Bezeichnungen  
specifications

Einheit  
unit

$a_e$

Spantiefe radial  
radial depth of cut

mm

$f_z$

Vorschub pro Zahn  
feed / tooth

mm

$h_m$

mittlere Spandicke  
medium thickness of chip

mm

$h_{max}$

maximale Spandicke  
maximum thickness of chip

mm

$n$

Spindeldrehzahl  
revolutions

U / min

$r$

Radius Fräser  
radius of cutter

mm

$V_c$

Schnittgeschwindigkeit  
cutting speeds

m / min

$V_f$

Vorschubgeschwindigkeit  
feed rate of tool center

mm / min

$z$

Schneidzahl Fräser  
number of cutting edges

Stk.  
pcs.

# SYSTEM 500

Nut- und Trennfräsen

groove milling  
and slotting cutter

# Technische Hinweise

Schnittdaten

Technical instructions,  
cutting data

	Werkstoff	Festigkeit	Werkstoff-Nr	Werkstoffbezeichnung	Werkstoff-Nr
P	Allgemeiner Baustahl	< 800 N/mm2	1.0037	St37-2	1.0570
	Automatenstahl	< 800 N/mm2	1.0718	9SMnPb28	1.0727
	Einsatzstahl unlegiert	< 800 N/mm2	1.0401	C15	1.0481
	Einsatzstahl legiert	< 1000 N/mm2	1.7331	16MnCr5 (EC80)	1.7015
	Vergütungsstahl unlegiert	< 850 N/mm2	1.0503	C45	1.1191
	Vergütungsstahl unlegiert	< 1000 N/mm2	1.0601	C60	1.1221
	Vergütungsstahl legiert	< 800 N/mm2	1.5131	50MnSi4	1.7030
	Vergütungsstahl legiert	< 1300 N/mm2	1.5755	31NiCr14	1.7033
	Stahlguss	< 850 N/mm2	0.9650	G-X260Cr27	1.6750
	Nitrierstahl	< 1000 N/mm2	1.8504	34CrAl6	1.8507
	Nitrierstahl	< 1200 N/mm2	1.8515	31CrMo12	1.8523
	Wälzlagerstahl	< 1200 N/mm2	1.3505	100Cr6 (W3)	1.3543
	Federstahl	< 1200 N/mm2	1.5026	55Si7	1.7176
	Schnellarbeitsstahl	< 1300 N/mm2	1.3344	S 6-5-3	1.3255
	Werkzeugstahl für Kaltarbeit	< 1300 N/mm2	1.2312	40CrMnMoS8 6	1.2379
	Werkzeugstahl für Warmbeit	< 1300 N/mm2	1.2343	X38CrMoV 5 1	1.2767
	M	Stahl und Stahlguss rostfrei geschwefelt	< 850 N/mm2	1.4305	X8CrNiS18 9
Nichtrostender Stahl, ferritisch		< 750 N/mm2	1.4510	X3CrTi17	1.4528
Nichtrostender Stahl, martensitisch		< 900 N/mm2	1.4034	X46Cr13	1.4116
Nichtrost. Stahl, ferritisch/martensit.		<1100 N/mm2	1.4313	X3CrNi13-4	1.4028
Nichtrost. Stahl, austenitisch/ferritisch		< 850 N/mm2	1.4460	X8CrNiMo27 5	1.4821
Nichtrostender Stahl, austenitisch		< 750 N/mm2	1.4301	X5CrNi18-10	1.4571
Hitzebeständig		< 1100 N/mm2	1.4747	X80CrNiSi20	1.4876
K	Grauguss mit Lammellengraphit	100-350N/mm2	0.6010	GG10	0.6025
	Grauguss mit Lammellengraphit	300-1000N/mm2	0.6030	GG30	0.6045
	Kugelgraphitguss	300-500N/mm2	0.7040	GGG40	0.7050
	Kugelgraphitguss	550-800N/mm2	0.7060	GGG60	0.7080
	Temperguss weis	350-450N/mm2	0.8035	GTW35	0.8045
	Temperguss weis	500-650N/mm2	0.8055	GTW55	0.8065
	Temperguss schwarz	350-450N/mm2	0.8135	GTS35	0.8145
Temperguss schwarz	500-700N/mm2	0.8155	GTS55	0.8170	
N	Aluminium ( unlegiert, niedrig legiert )	< 350 N/mm2	3.0255	Al99,5	3.3308
	Aluminiumlegierungen < 0,5% Si	< 500 N/mm2	3.0515	AlMn1	3.1355
	Aluminiumlegierungen 0,5-10% Si	< 400 N/mm2	3.2152	GD-AlSi6Cu4	3.2373
	Aluminiumlegierungen 10-15% Si	< 400 N/mm2	3.2381	G-AlSi10Mg	3.5562
	Aluminiumlegierungen > 15% Si	< 400 N/mm2		G-AlSi17Cu4	
	Kupfer ( unlegiert, niedrig legiert )	< 350 N/mm2	2.0060	E-Cu57	2.0090
	Kupfer-Knetlegierungen	< 700 N/mm2	2.0240	CuZn15	2.0265
	Kupfer-Sonderlegierungen	< 200 HB	2.0916	CuAl5	2.1525
	Kupfer-Sonderlegierungen	< 300HB	2.0978	CuAl11Ni6Fe5	
	Kupfer-Sonderlegierungen	> 300 HB	2.1247	CuBe2F125	
	Messing kurzspanend, Bronze, Rotguss	< 600 N/mm2	2.0360	CuZn40 (Ms60)	2.0380
	Messing langspanend	< 600 N/mm2	2.0335	CuZn36 (Ms63)	2.1293
	Thermoplaste			Delrin, Hostalen	
	Duroplaste			Ferrozell, Bakelit	
	Faserverstärkte Kunststoffe			GFK (Glasfaserverstärkt )	
	Magnesium und Magnesiumlegierungen	< 850 N/mm2	3.5200	M2, MgMn2	3.5612
	Graphit			C8000, R8500X	
Wolfram und Wolframlegierungen			W-NiFe (Densimet W)		
Molybdän und Molybdänlegierungen			Mo , Mo-50Re		
S	Reinnickel		1.3911	RNi24	1.3927
	Nickellegierungen		1.3912	Ni36 (Invar)	1.3924
	Nickellegierungen	< 850 N/mm2	2.4360	S-NiCu 30 Fe	
	Nickel-Chromlegierungen		2.4886	SG-NiMo16Cr16W	2.4610
	Nickel- und Kobaltlegierungen	< 1300 N/mm2	2.4632	NiCr20Co18Ti	2.4631
	Nickel- und Kobaltlegierungen	< 1300 N/mm2	2.4634	NiCo20Cr15MoAlTi	2.4654
	Hochwärmefeste Legierungen	< 1300 N/mm2		Hardox 400	1.4939
	Nickel-Kobalt-(Chrom-)legierungen	< 1400 N/mm2	2.4806	SG-NiCr20Nb, Inconel 82	2.4851
	Reintitan	< 900 N/mm2	3.7025	Ti99,8	3.7034
	Titanlegierungen	< 700 N/mm2	3.7114	TiAl5Sn2	3.7174
Titanlegierungen	< 1200 N/mm2	3.7164	TiAl5V4	3.7144	
H	Stahl gehärtet	< 45 HRc			
		46-55HRc			
		56-60 HRc			
		61-65 HRc			
	65-70 HRc				

# SYSTEM 500

Nut- und Trennfräsen

groove milling  
and slotting cutter

# Technische Hinweise

Schnittdaten

Technical instructions,  
cutting data

Werkstoffbezeichnung	Werkstoff- Nr	Werkstoffbezeichnung	Vc (m/min.)	fz (mm)	mit/with AL41F
St52-3	1.0060	St60-2	160-240	0,05 - 0,15	Haupt- Anwendung
45S20	1.0757	46SPb2		0,05 - 0,15	
17Mn4	1.1141	C15E (CK15)		0,05 - 0,15	
13Cr3 (EC60)	1.5919	15CrNi6	70-150	0,05 - 0,12	
Ck45	1.0535	C55	50-70	0,05 - 0,12	
Ck60	1.0540	C50		0,05 - 0,12	
28Cr4	1.7225	42CrMo4		0,05 - 0,15	
34Cr4	1.3565	48CrMo4	80-120	0,02 - 0,1	
GS-20NiCrMo3 7	1.6582	GS-34 CrNiMo 6		0,05 - 0,15	
34AlMo5	1.8509	41CrAlMo7		0,03 - 0,12	
39CrMoV19 3	1.8550	34 CrAlNi 7	60-130	0,02 - 0,1	
X192CrMo17	1.3520	100 CrMn 6 (W4)		0,02 - 0,1	
55Cr3	1.7701	51CrMoV4		0,02 - 0,1	
S 18-1-2-5	1.3294	PMHS6-5-3-8; ASP30	80-150	0,02 - 0,1	
X155CrVMo12 1	1.2316	X38CrMo16; RAMAX		0,02 - 0,1	
X45NiCrMo4	1.2842	90MnCrV8		0,02 - 0,1	
X4CrMoS18	1.4107	GX8CrNi12	Haupt- Anwendung	0,03 - 0,12	
X105CrCoMo18 2	1.4016	X6Cr17		0,05 - 0,15	
X50CrMoV15	1.4106	X2CrMoSi18-2-1		0,02 - 0,1	
X30Cr13	1.4104	X14CrMoS17	Haupt- Anwendung	0,02 - 0,1	
X20CrNiSi25 4	1.4462	X2CrNiMoN22-5-3 (Duplex)		0,02 - 0,1	
X6CrNiMoTi17 12 2	1.4449	X3CrNiMo18-12-3		0,02 - 0,1	
X10NiCrAlTi32-21	1.4825	GX25CrNiSi18-9	Haupt- Anwendung	0,02 - 0,1	
GG25				0,03 - 0,15	
GG45				0,03 - 0,15	
GGG50			Haupt- Anwendung	0,03 - 0,15	
GGG80				0,03 - 0,15	
GTW45				0,03 - 0,15	
GTW65			Haupt- Anwendung	0,03 - 0,15	
GTS45				0,03 - 0,15	
GTS70				0,03 - 0,15	
Al99,9Mg0,5	3.0256	E-Al H	500-700	0,05 - 0,15	
AlCuMg2	3.3315	AlMg1		0,05 - 0,15	
GD-AlSi9Mg	3.2134	GD-AlSi5Cu1Mg		0,05 - 0,15	
G-MgAl6	3.2525	S-AlSi12	Haupt- Anwendung	0,05 - 0,15	
G-AlSi25CuNiMg		G-AlSi21CuNiMg		0,05 - 0,15	
SF-Cu	2.1522	CuSi2Mn		0,05 - 0,15	
CuZn30	2.0321	CuZn37	200-500	0,05 - 0,15	
CuSi3Mn		Ampco 8-16		0,05 - 0,15	
		Ampco18-26		0,05 - 0,15	
		Ampco M-4	80-220	0,05 - 0,15	
CuZn39Pb2 (Ms58)	2.0410	CuZn44Pb2		0,05 - 0,15	
CuCrZr	2.1080	CuSn6Zn6		0,05 - 0,15	
Makrolon, Novodur		Acrylglas, Polystyrol	Haupt- Anwendung	0,05 - 0,25	
Pertinax		Resopal		0,05 - 0,25	
CFK (Kohlefaserverstärkt)		AFK (Amidfaserverstärkt)		0,05 - 0,15	
MgAl6Zn1	3.5812	MgAl8Zn1	100-350	0,02 - 0,1	
R8650		Technograph15		0,05 - 0,15	
W-Cu80/20		W93NiFe (DENAL)		0,02 - 0,1	
TZC, TZM		MHC, ODS	Haupt- Anwendung	0,02 - 0,1	
RNi8	1.3926	RNi12		0,005 - 0,07	
Ni54	1.3921	Ni49		0,005 - 0,07	
NiCu 30 Fe		Monel 400	40-120	0,005 - 0,07	
NiMo16Cr16Ti		Hastelloy C-276		0,005 - 0,07	
NiCr20TiAl		Nimonic 80		0,005 - 0,07	
NiCr19Co14Mo4Ti		Waspaloy	Haupt- Anwendung	0,005 - 0,07	
X12CrNiMo12	1.4980	X6NiCrTiMoVB25-15-2		0,005 - 0,07	
NiCr23Fe, Inconel 601	2.4667	SG-NiCr19NbMoTi		0,005 - 0,07	
Ti99,7	3.7064	Ti99,5	Haupt- Anwendung	0,005 - 0,07	
TiAl6V6Sn2	3.7124	TiCu2		0,005 - 0,07	
TiAl6Sn2Zr4Mo2	3.7154	TiAl6Zr5		0,005 - 0,07	
			30-80	0,003 - 0,05	
				0,002 - 0,05	
				0,001 - 0,05	
			-	-	Neben- Anwendung
			-	-	









 **Dümmel**  
WERKZEUGFABRIK

rotaline



Ausspindeln ab  $\varnothing$  0.4 mm

Precision boring starting at  $\varnothing$  0.4 mm

 **BROTECH**

## ROTALINE

Ausspindeln  
ab  $\varnothing 0.4$  mm

precision boring  
starting at  $\varnothing 0.4$  mm

## Übersicht

summary



Allgemeine Beschreibung

general instructions

... 462



**Rotaline**

**Rotaline**

**Maße  
dimensions**

**Seite  
page**

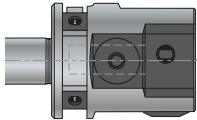

**ROTA-HSP0410**

Abmessungen und Merkmale

**ROTA-HSP0410**

characteristics

... 463

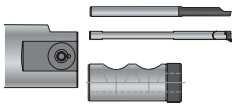

**Aufbau  
Reduzierhülsen**

**configuration  
reducing sleeves**

... 464



**HM-Ausdrehschneiden**

D min. 0.4 – 10.4 mm

**carbide mini boring tool**

D min. 0.4 – 10.4 mm

... 465



**HM-Ausdrehschneiden**

D min. 9.3 – 15.8 mm

**carbide mini boring tool**

D min. 9.3 – 15.8 mm

... 466

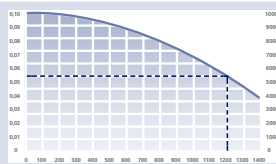

**Technische Hinweise**

**Technical Instructions**

**Seite  
page**

Ersatzteile /  
maximale Drehzahlen

spare parts /  
max. rpm

... 467

Schnittdaten

cutting data

... 468

Hartmetallsorten und Beschichtungen

carbide grades and coatings

... 469

## ROTALINE

Ausspindeln  
ab  $\varnothing$  0.4 mm

precision boring  
starting at  $\varnothing$  0.4 mm

## Allgemeine Beschreibung

general instruction

### rotaline

ROTA-HSP0410 Anwendungsbeispiel

ROTA-HSP0410 exemplary application



Verbessern Sie jetzt Präzision, Qualität und Effizienz bei der Fertigbearbeitung kleinster Bohrungen. Mit unserem neuen, universellen Highspeed Feindrehwerkzeug mit integrierter Digitalanzeige für die Bearbeitung von Bohrungen ab  $\varnothing$  0.4 mm.

- Max. zulässige Drehzahl 35 000/min
- Körperdurchmesser 40 mm
- Auf Grund geringer Baumaße hervorragend geeignet zum Einsatz auf kompakten Maschinen ab Spindelgröße HSK 40.

Ergänzt werden die Werkzeuge durch ein komplettes Zubehörprogramm, das eigens für dieses Werkzeug konzipiert wurde – flexibel, effizient,  $\mu$ -genau.

Überzeugen Sie sich selbst von der Leistungsfähigkeit des Highspeed Werkzeugs.

You can now improve precision, quality and efficiency when finish boring smallest diameters. With our new, universal high speed precision boring tool with integrated digital display for boring operations from a diameter of 0.4 mm.

- Max. permissible speed of 35 000/min
- Body diameter 40 mm
- Due to its small size this tool is ideally suited for compact machines from a spindle size of HSK 40.

The tool is augmented by a complete range of accessories, which have been designed for this tool – flexible, efficient and extremely accurate.

Check out the performance of the high-speed tools for yourself – come and try us out!

## ROTALINE

Ausspindeln  
ab  $\varnothing 0.4$  mm

precision boring  
starting at  $\varnothing 0.4$  mm

## Abmessungen und Merkmale

characteristics

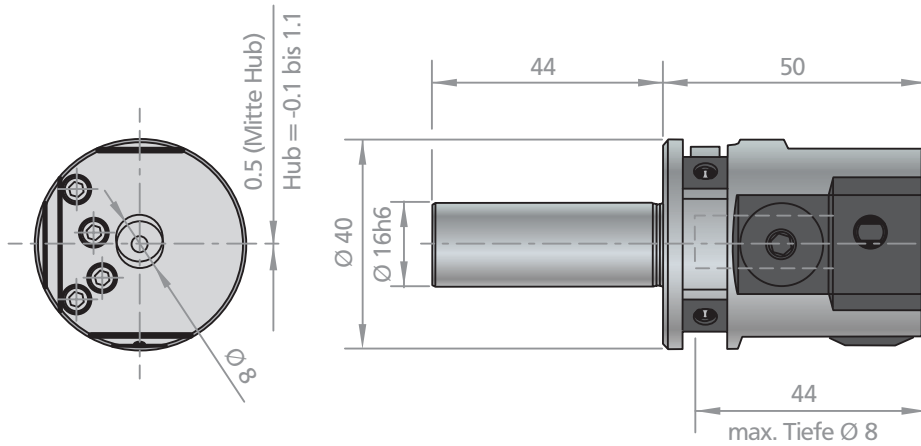

**Gewicht / weight**  
kg

0.42

**Ausdrehbereich / boring range**  
A

$\varnothing 0.4 - \varnothing 15$

- Einfachste Handhabung dank Digitalanzeige.
- Zustellgenauigkeit 0.002 mm im Durchmesser.
- 1,2 mm radiale Hubverstellung.
- Stufenlos axial einstellbare Schneiden.
- Automatisch definierte Schneidenlage.
- Zylindrischer Schaft für flexible Anwendungen.
- Innere Kühlschmierstoffzufuhr (max. 40 bar).
- Manuelle Feinwuchtung über Ausgleichgewichte.
- Wasser- und staubgeschützt gemäß IP65.
- Nicht im Hydrodehnspannfutter einsetzen!

- Easiest possible handling thanks to digital display.
- Feed-in accuracy 0.002 mm in diameter.
- 1.2 mm radial stroke adjustment.
- Continuously variable axially-adjustable cutting tools.
- Automatically defined cutting edge position.
- Cylindrical shaft for flexible applications.
- Internal coolant supply (max. 40 bar).
- Manual precision balancing through balancing weights.
- Protected against water and dust according to IP65
- Don't use in a hydraulic expansion chuck!

# ROTALINE

Ausspindeln  
ab  $\varnothing 0.4$  mm

precision boring  
starting at  $\varnothing 0.4$  mm

# Aufbau / Reduzierhülse

configuration / reducing sleeves

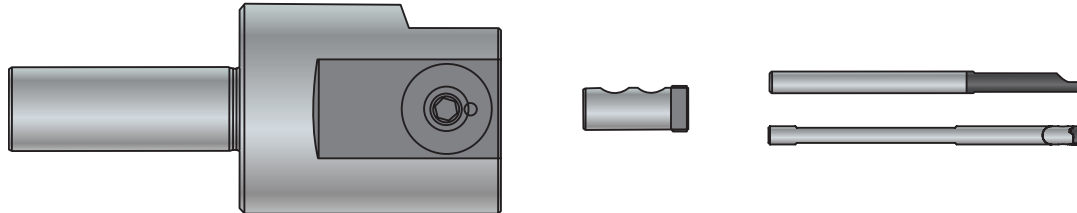

Ausspindelkopf precision boring tool	Reduzierhülse reducing sleeve	HM-Ausdrehschneide mini boring tool	
ROTA-HSP0410	RB04-ROTA	ROTA04-020 R ROTA06-030 R ROTA08-040 R ROTA10-050 R ROTA15-075 R ROTA20-100 R ROTA25-125 R ROTA28-140 R ROTA35-180 R ROTA40-200 R	
	RB05-ROTA	ROTA50-255 R	
	RB06-ROTA	ROTA60-320 R	
	RB07-ROTA	ROTA70-405 R	
	—	ROTA80-505 R	
	RB06-ROTA	V08.006.2 HM	RS08.1846.02
		V11.008.2 HM	RS11.1855.02 RS11.1867.02

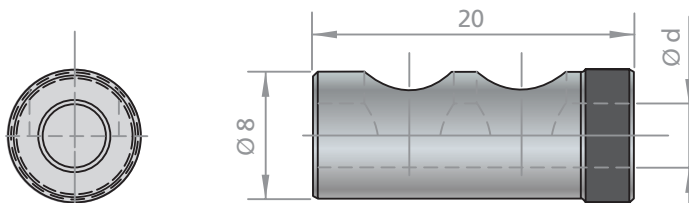

Best. Nummer part number	d		
-----------------------------	---	--	--

RB04-ROTA	4
RB05-ROTA	5
RB06-ROTA	6
RB07-ROTA *	7

\* ohne IK      \* without IK

## ROTALINE

Ausspindeln  
ab  $\varnothing$  0.4 mm

precision boring  
starting at  $\varnothing$  0.4 mm

## HM-Ausdrehschneiden

D min. 0.4 - 10.4 mm

carbide mini boring tool

D min. 0.4 - 10.4 mm

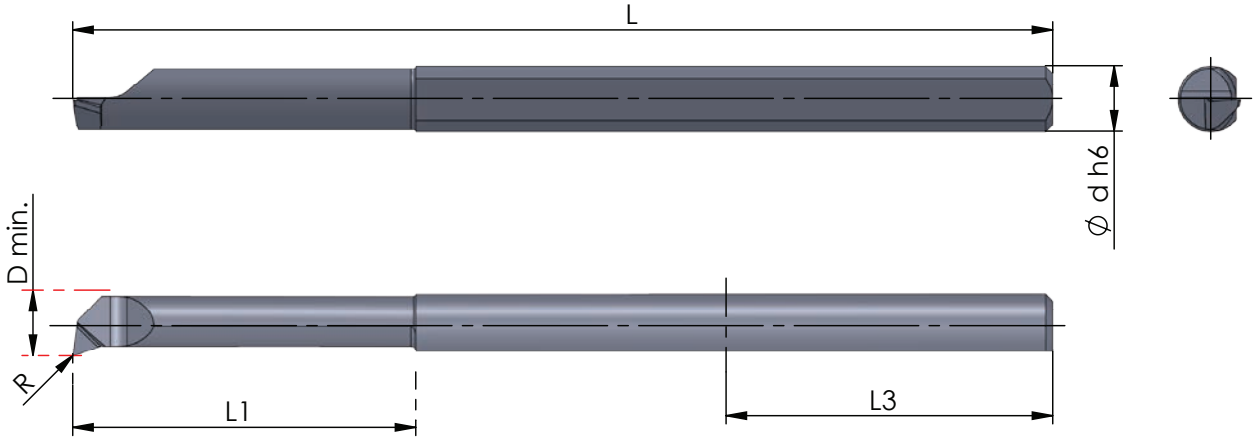

Best. Nummer part number	D min.	$\varnothing d h6$	L	L1	R	L3 Mindest- einspannlänge min. clamping length	Standard Ausführung basic version
ROTA04-020 R	0.4	4	42.0	2.0	0.03	20	AL41F XC2A-NH
ROTA06-030 R	0.6	4	43.0	3.0	0.04	20	
ROTA08-040 R	0.8	4	44.0	4.0	0.04	20	
ROTA10-050 R	1.0	4	45.0	5.0	0.05	20	
ROTA15-075 R	1.5	4	47.5	7.5	0.05	20	
ROTA20-100 R	2.0	4	50.0	10.0	0.05	20	
ROTA25-125 R	2.5	4	52.5	12.5	0.05	20	
ROTA28-140 R	2.8	4	54.0	14.0	0.07	20	
ROTA35-180 R	3.5	4	58.0	18.0	0.10	20	
ROTA40-200 R	4.0	4	60.0	20.0	0.10	20	
ROTA50-255 R	5.0	5	66.0	25.5	0.12	20	
ROTA60-320 R	6.0	6	75.0	32.0	0.15	20	
ROTA70-405 R	7.0	7	82.0	40.5	0.20	20	
ROTA80-505 R	8.0	8	92.0	50.5	0.20	20	

AL41F  
XC2A-NH

Standardausführung  
für die Hartbearbeitung bis 66 HRC

basic version  
for hard machining up to 66 HRC

Weitere HM Sorten können Sie in der Sorten-  
übersicht im Kapitel "Technische Hinweise" und  
der Preisliste finden.

Bestellbeispiel:  
für rechte Ausführung und Sorte  
ROTA04-020R/AL41F

More carbide grades you can find in the grades  
summary in the chapter "technical instructions"  
and in the price list.

order-example:  
righthand version and grade  
ROTA04-020R/AL41F

**BROTECH**

# ROTALINE

Ausspindeln  
ab Ø 0.4 mm

precision boring  
starting at Ø 0.4 mm

# HM-Ausdrehschneiden

carbide mini boring tool

D min. 9.3 - 15.8 mm

D min. 9.3 - 15.8 mm

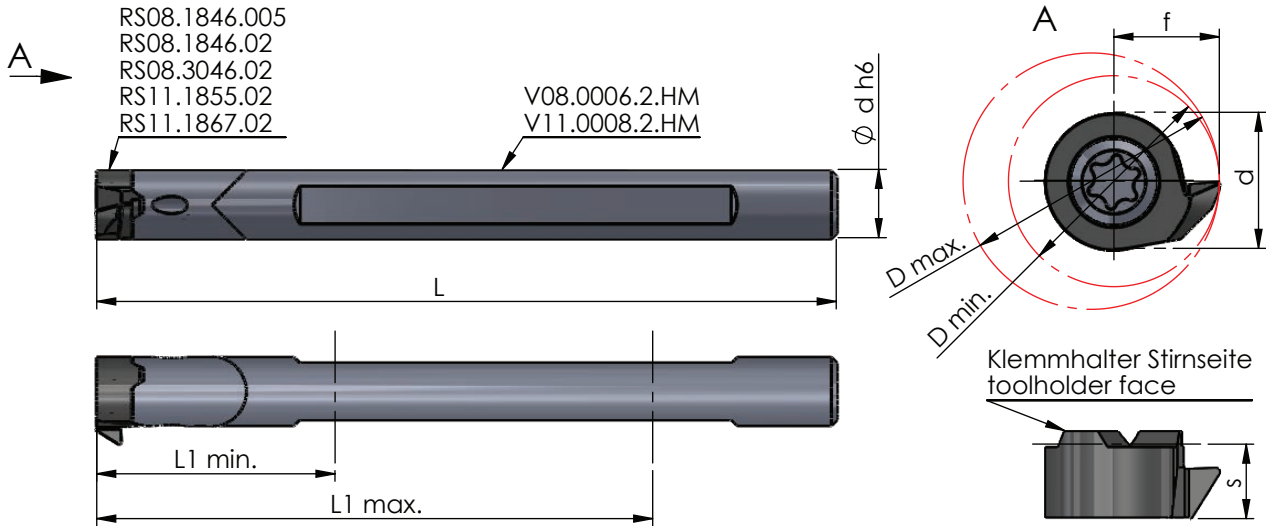

Ausführung rechts (R)

state right (R) version

Abmessungen in mm

dimensions in mm



Bestellnummer part number	D min.	D max.	Ø d h6	L	L1 min.	L1 max.		für Schneidplatte use with insert
V08.0006.2HM	9.3	11.7	6	65	21	49	- IK	RS08,...
V11.0008.2HM	11	15.8	8	79	35	63	+ IK	RS11,...

Bestellnummer part number	D min.	D max.	f	s	d	Ap max.*	R	für Halter for holder
RS08.1846.005	9.3	11.7	4.65	3.5	6	0.6	0.5	V08.0006.2HM
RS08.1846.02	9.3	11.7	4.65	3.5	6	0.6	0.2	
RS08.3046.02	9.3	11.7	4.65	3.5	6	0.6	0.2	
RS11.1855.02	11.0	13.4	5.5	4.2	8	1.0	0.2	V11.0008.2HM
RS11.1867.02	13.4	15.8	6.7	4.2	8	1.0	0.2	

\* Ap max. = maximale Schnitttiefe  
(werkstoffabhängig)

Achtung: Schneide muss in Richtung  
Spannschrauben zeigen!

Ab Ø 12 mm Schneidwerte  
um ca. 30% reduzieren!

Weitere HM Sorten können Sie in der Sorten-  
übersicht im Kapitel "Technische Hinweise" und  
der Preisliste finden.

Bestellbeispiel:  
für rechte Ausführung und Sorte AL41F:  
RS08.1846.02/AL41F

\* Ap. max = maximum depth of cut  
(depending on material)

Attention: cutting edge has to face  
towards the clamp screw!

From diameter 12 mm reduce cutting  
data about 30%!

More carbide grades you can find in the  
grades summary in the chapter "technical  
instructions" and in the price list.

order example:  
righthand version and grade AL41F:  
RS08.1846.02/AL41F



## ROTALINE

Ausspindeln  
ab  $\varnothing$  0.4 mm

precision boring  
starting at  $\varnothing$  0.4 mm

## Technische Hinweise

Ersatzteile / Maximale Drehzahlen

Technical instructions,  
spare parts / max. rpm

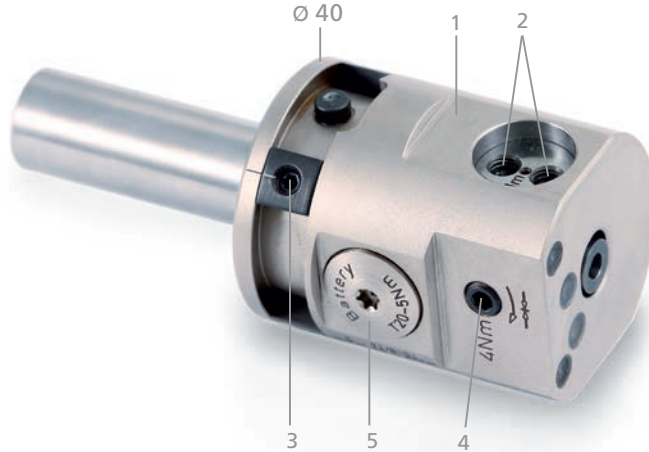

### Ersatzteile

### spare parts

Teil part	Best. Nummer part number	Schlüssel key	Nummer number	Moment Nm moment Nm
Batterie	ROTA-BAT			
1 Ausspindelkopf	ROTA-HSP0410			
2 Gewindestift	ROTA-M5	T-Schlüssel SW2.5	DS SW25	3
3 Gewindestift	ROTA-M4	T-Schlüssel SW2	DS SW20	2.5
4 Gewindestift	ROTA-M6	T-Schlüssel SW3	DS SW30	4
5 Batteriefachdeckel	ROTA-DCK	Torx T20	TORX T20F	5
Dichtung für Batteriefachdeckel	ROTA-DIC			

### Maximale Drehzahl

### max. rpm

Ausdrehbereich boring range $\varnothing$ mm	Auskraglänge overhang length	Max. zulässige Drehzahl max. rpm (1/min)
0.4 - 6.0	max. zulässig max.	35.000
6.0 - 12.0	< 5x Schaft- $\varnothing$ < 5x shank- $\varnothing$	35.000
6.0 - 12.0	> 5x Schaft- $\varnothing$ > 5x shank- $\varnothing$	25.000

## ROTALINE

Ausspindeln  
ab Ø 0.4 mm

precision boring  
starting at Ø 0.4 mm

## Technische Hinweise

Schnittdaten

Technical instructions,  
cutting data

zu bearbeitender Werkstoff	Ausdrehbereich	Schnittgeschw. Vc = m/min (gilt für ausgewuchtete Werkzeuge)	Vorschub
machining material	boring range	cutting speeds Vc = m/min (only for balanced tools)	feed
<b>Stahl unlegiert</b> steel unalloyed	0.4 - 1.0 1.0 - 8.0	30 - 100 60 - 180	0.01 - 0.02 0.02 - 0.06
<b>Stahl legiert</b> steel alloyed	0.4 - 1.0 1.0 - 8.0	30 - 100 60 - 150	0.01 - 0.02 0.02 - 0.06
<b>Stahl hochlegiert</b> steel high alloyed	0.4 - 1.0 1.0 - 8.0	30 - 100 60 - 120	0.01 - 0.02 0.02 - 0.06
<b>Stahl rostfrei</b> steel stainless	0.4 - 1.0 1.0 - 8.0	30 - 80 40 - 130	0.01 - 0.02 0.02 - 0.06
<b>Grauguß</b> cast iron	0.4 - 1.0 1.0 - 8.0	30 - 100 50 - 170	0.01 - 0.02 0.02 - 0.06
<b>Sphäroguß</b> spheroidal graphite cast iron	0.4 - 1.0 1.0 - 8.0	30 - 100 50 - 170	0.01 - 0.02 0.02 - 0.06
<b>Aluminium Leg. langspanend</b> aluminium alloy, long-chipped	0.4 - 1.0 1.0 - 8.0	40 - 200 180 - 600	0.01 - 0.02 0.02 - 0.06
<b>Aluminium Leg. kurzspanend</b> aluminium alloy, short-chipped	0.4 - 1.0 1.0 - 8.0	40 - 200 180 - 600	0.01 - 0.02 0.02 - 0.06
<b>Warmfeste Legierungen</b> high temperature alloy	0.4 - 1.0 1.0 - 8.0	20 - 60 30 - 80	0.01 - 0.02 0.02 - 0.06
<b>geh. Stahl bis 66 HRC</b> hardend steel to 66 HRC	0.4 - 1.0 1.0 - 8.0	50 - 100 50 - 100	0.01 - 0.02 0.02 - 0.06



Nicht ausgewuchtete Werkzeuge sollten mit stark reduzierter Schnittgeschwindigkeit gefahren werden.

Not balanced tools should work with drastically reduced cutting speed.

## ROTALINE

Ausspindeln  
ab Ø 0.4 mm

precision boring  
starting at Ø 0.4 mm

## Technische Hinweise

Hartmetallsorten und Beschichtungen

Technical instructions,  
carbide grades and coatings

### K10F

Universell einsetzbares Feinkornhartmetall mit guter Verschleißfestigkeit. Unbeschichtet geeignet für Anwendungen mit niedrigen und mittleren Schnittgeschwindigkeiten, sowie die Bearbeitung von Nicht-eisenmetallen.

All purpose micrograin carbide with good abrasion resistance. Uncoated for applications with low or medium cutting speeds and machining of non-ferrous materials.

### CBN

Zähe CBN-Sorte für Anwendungen mit niedrigen Schnittgeschwindigkeiten. Geeignet für gehärtete Stähle, unterbrochene Schnitte und Grauguss.

Ductile CBN grade for applications with lower cutting speed. Suitable for hardened steel, interrupted cuts and cast iron.

### CN45F

Universell einsetzbare PVD-TiN-Beschichtung. Diese Allround-Sorte ist für niedrige und mittlere Schnittgeschwindigkeiten mit Einschränkung bei NE-Metallen

PVD-TiN coating - all purpose, all around grade is suitable for low and medium cutting speed with restrictions on non-ferrous materials.

### AL41F

Sehr universell einsetzbare TiAlN-Beschichtung mit hoher Temperaturbeständigkeit bei hoher Härte. Sehr gut geeignet auch für NE-Metalle.

TiAlN coating - very universal with a high resistance to high temperature and hardness. Very suitable also for non-ferrous metals.

### PD2F

Beschichtung für den universellen Einsatz bei niedrigen und mittleren Schnittgeschwindigkeiten.

Coating for universal use with medium and low speed.

### XC2A

Beschichtung mit einer excellenten Warmhärte, Oxidationsbeständigkeit und thermischen Isolationsfähigkeit. Ideal für Hartzerspannung >60HRC

Coating with excellent hot hardness, high oxidation resistance and thermal insulation capacity. Perfect for hard machining >60 HRC.

## ROTALINE

Ausspindeln  
ab  $\varnothing$  0.4 mm

precision boring  
starting at  $\varnothing$  0.4 mm

## Technische Hinweise

Hartmetallsorten und Beschichtungen

Technical instructions,  
carbide grades and coatings

### P01C

Beschichtung für die Bearbeitung in zähen Materialien bei niedrigen und mittleren Schnittgeschwindigkeiten.

Coating for the processing in tough material with medium or low cutting speed

### P03C

Beschichtung für die Bearbeitung von schwer zerspanbaren Materialien. Sehr gut auch für die Trockenbearbeitung geeignet.

Coating for materials which are difficult to machine. Perfect to use for dry machining.

### P07C

Beschichtung für die Bearbeitung von Titan, Edelstahl und Molybdän.

Coating to machine titanium, stainless steel and molybdenum.

### P18C

Universell einsetzbare Hochleistungsschicht mit hoher Oxidationsbeständigkeit, Verschleißfestigkeit und Warmhärte.

Very universal high performance coating with high oxidation resistance, wear resistance and hot hardness resistance.

### NEME

Beschichtung für die Bearbeitung von Aluminium, Al-Legierungen, NE-Metallen und Composite-Werkstoffen.

Coating for machining aluminium, alloys, non-ferrous metals and composite materials.



Notiz

notice



A large area of the page is filled with horizontal dotted lines, providing a space for writing notes.



Notiz

notice



# Jahre

**Dümme** WERKZEUGFABRIK

Zertifiziert nach / certified to  
DIN EN ISO 9001: 2015

**MINDESTBESTELLMENGE**  
für Schneidplatten beträgt  
die Mindestbestellmenge  
2 Stück, für Halter 1 Stück.

**MINIMUM ORDER QUANTITY**  
for inserts the minimum order  
quantity is 2 pieces,  
for toolholders 1 piece.

**MINDESTBESTELLWERT**  
der Mindestbestellwert pro  
Auftrag beträgt € 80,- Netto  
(ausschließlich Umsatzsteuer).  
Für Aufträge unter € 80,-  
berechnen wir einen Zuschlag  
für Kleinaufträge in Höhe  
von € 20,-.

**MINIMUM ORDER VALUE**  
the minimum order value for  
one order is € 80,- net.  
(excluded sales tax).  
For orders less than € 80,-  
we have an additional order  
charge of € 20,-.

© Stand 09/2018  
Urheberrechtlich geschützt.

© edition 09/2018  
copyright reserved.

Katalognachdruck oder  
Veröffentlichung auch  
auszugsweise verboten.

reprint or publishing of the  
catalogue complete or in  
extracts prohibited.

Technische Änderungen und  
Irrtümer vorbehalten, keine  
Gewährleistung für  
Druckfehler.

technical changes and errors  
reserved, no warranty for  
missprints.

