

Saw Man-X

Insert: N Chip breaker (basic/lead angle type ^{New}), S Chip breaker ^{New}

Holder: Blade (basic/high pressure coolant ^{New}), shank type

A solution for parting and deep grooving

- Stable machining in deep grooving applying clamping system with strong three-way V-Rail
- Improving clamping precision and convenient replacing of inserts with using the exclusive wrench

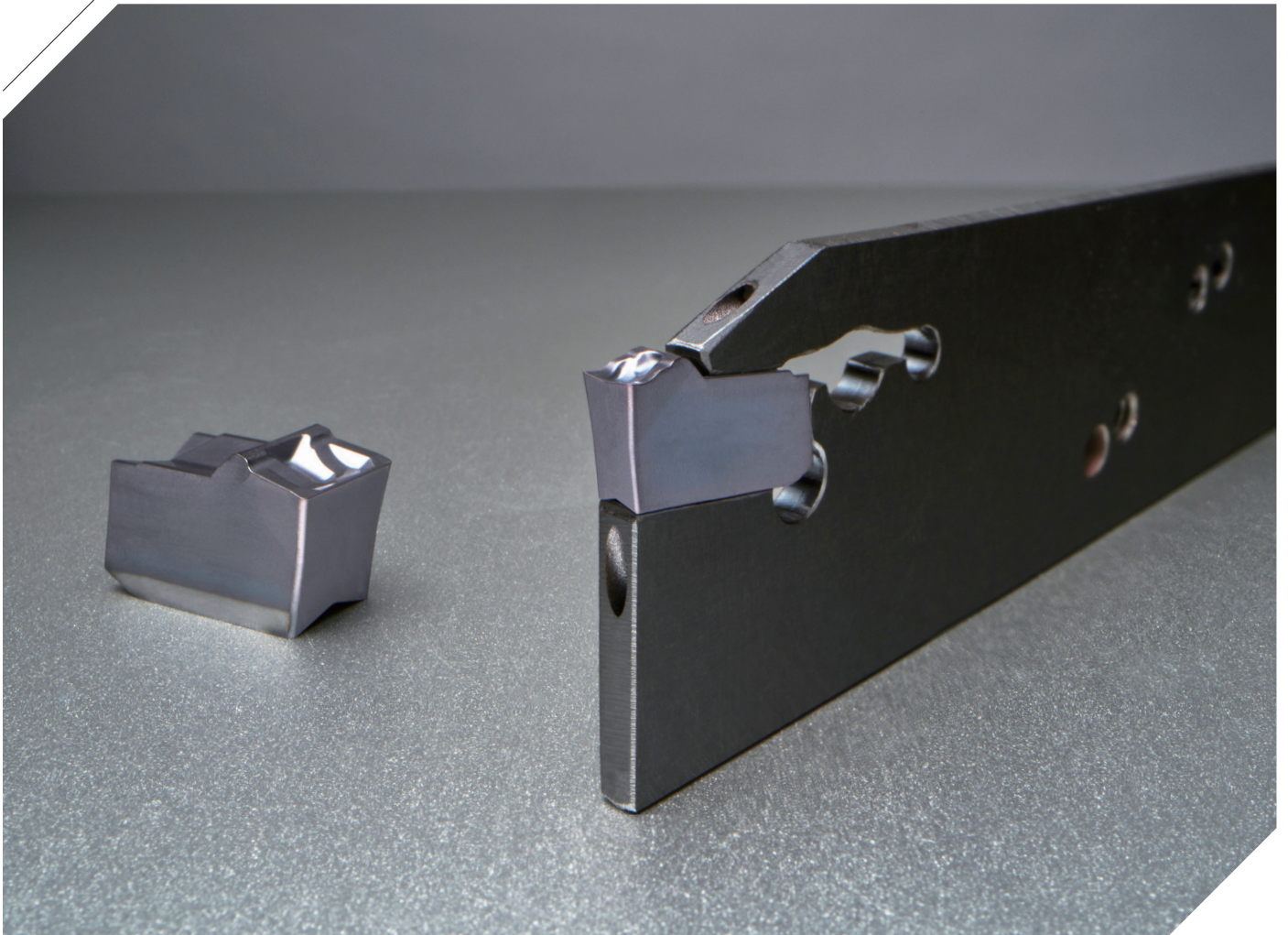

A solution for parting and deep grooving

Saw Man-X

The stable clamping system of an insert and a holder is the most important factor in parting and deep grooving due to vibration from long overhang, and narrow machining width making unexpected fracture of insert and breakage of holder.

Saw Man-X insert with specially designed three-way (top, bottom and back side) concave V-Rail increases the clamping force. In addition, the optimal chip breaker and bump in the back side of insert reduce chip width effectively and minimize scratch and chip curling due to controlling chip radius.

Saw Man-X holder has strong clamping structure due to three-way convex V-Rail ensuring perfect clamping insert in the seat of holder. Therefore, it realizes stable clamping in high speed and high feed cutting. Especially blade and block with high pressure internal spraying can maximize cooling efficiency when machining HRSA.

In addition, the exclusive self-clamping structure ensures stable clamping and durability of holder in machining with long overhang. The application of stopper in the back side and exclusive wrench increase repeated clamping precision and make replacing insert easy.

Saw Man-X ensures stable quality of machining, long tool life and convenient clamping system in high speed and high feed machining due to applying three-way V-Rail shape, differentiated chip breaker design and exclusive wrench. Through these advantages, Saw Man-X provides effective and economical solutions in parting and deep grooving.

» **Stable clamping system in high speed and high feed machining**

- Three-way V-Rail structure

» **Enhanced convenience in insert replacement**

- Using the exclusive wrench

» **Optimal chip breaker by workpieces**

- N Chip breaker : steel, cast iron
- S Chip breaker : Stainless steel, HRSA

» **More efficient cooling in applying high pressure inner coolant**

- 2 channel direct spraying on cutting edge
- Longer tool life in HRSA cutting

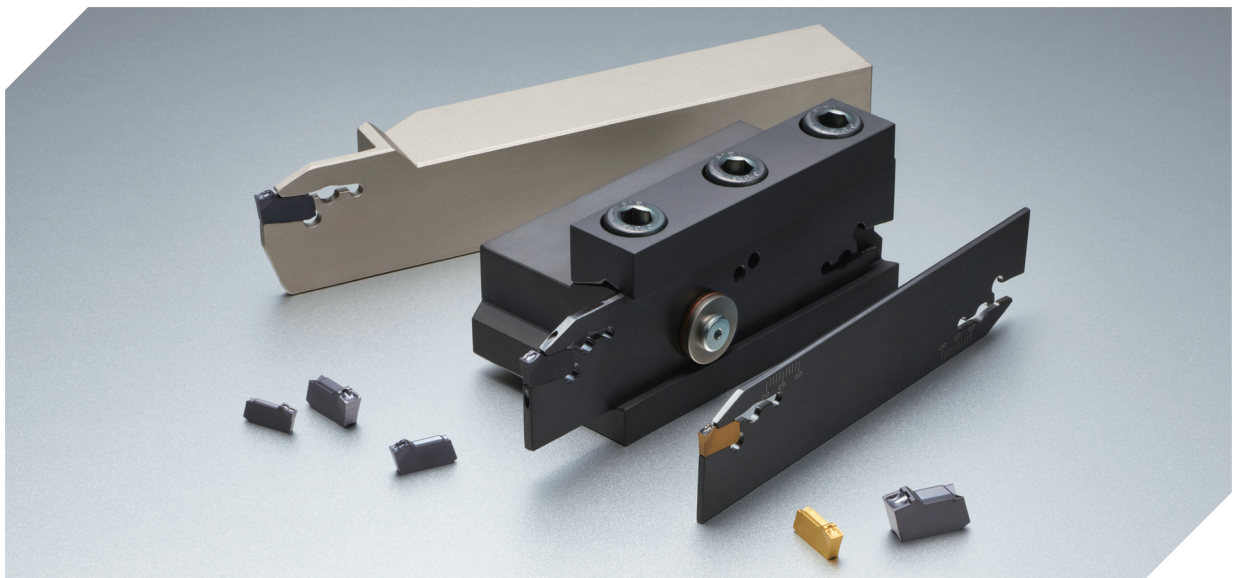

Code system

Insert (Basic)

KSP	300	-	020	-	N
KORLOY Saw Man-X Parting	Cutting width 200: 2 mm 300: 3 mm 400: 4 mm		Nose r 020: 0.2 mm 030: 0.3 mm		Chip breaker N: P, K series S: M, S series

Insert (Lead angle type)

KSP	300	R	-	6D	-	N
KORLOY Saw Man-X Parting	Cutting width 200: 2 mm 300: 3 mm 400: 4 mm	Hand R: Right handed L: Left handed		Lead angle 4D: 4° 6D: 6°		Chip breaker N: P, K series S: M, S series

Blade

KSPB	30	32	-	(KHP)
KORLOY Saw Man-X Parting Blade	Cutting width 20: 2 mm 30: 3 mm 40: 4 mm	Blade height 26: 26 mm 32: 32 mm		Oil hole None: Without oil hole KHP: High pressure coolant

Shank

KSPH	3	-	25	R
KORLOY Saw Man-X Parting Holder	Cutting width 2: 2 mm 3: 3 mm 4: 4 mm		Shank size 16: 1616 20: 2020 25: 2525	Hand R: Right handed L: Left handed

Features

- Three-way V-Rail - More stable clamping system
- Superior chip breaker - Better chip control
- Exclusive wrench - More convenient clamping system
- 2 channel spraying through high pressure coolant - More efficient cooling

Three-way V-Rail

- Tightly clamped inset in the tip seat
- Increased stability by minimized vibration during the machining
- Available for stable high speed, high feed and high depth of cut machining

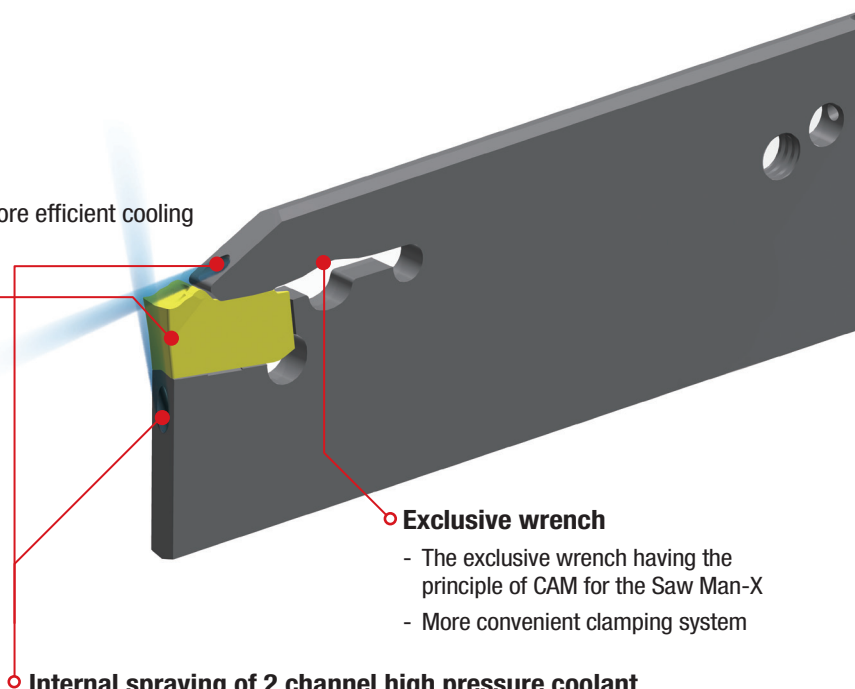
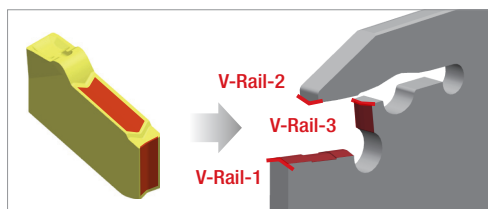

Internal spraying of 2 channel high pressure coolant

- Direct spraying of cutting edge coolant for effective coolant
- Longer tool life in HRSA cutting
(*need for exclusive blade and block for high pressure coolant)

✔ How to clamp insert

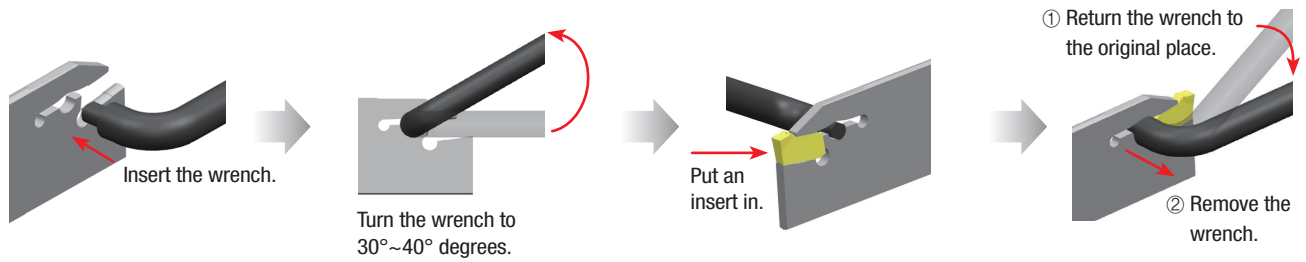

✔ Chip breaker features

Type	Shape	Cutting edge	Features
N Chip breaker			<ul style="list-style-type: none"> • 1st recommended in steel and cast iron cutting • Negative land cutting edge • For interrupted and high feed cutting
S Chip breaker <i>New</i>			<ul style="list-style-type: none"> • 1st recommended in Stainless steel and HRSA cutting • Sharp cutting edge • For high speed and continuous cutting
N Chip breaker <i>New</i> (Lead angle type)			<ul style="list-style-type: none"> • Optimal for pipe and round bar cutting • Negative land cutting edge applying lead angle • Minimized burr and size of PIP

✔ Effect of applying lead angle

Insert	Right-handed lead angle	Left-handed lead angle
Controlling PIP size		
Effect	Minimizing PIP size to the direction of cutting part	Minimizing PIP size to the direction of workpiece

Recommended cutting conditions _ N Chip breaker

Workpiece				Specific cutting force (N/mm ²)	Brinell hardness (HB)	Wear resistance ← • → Toughness			Grooving /parting
ISO	Workpiece materials	ISO (DIN)	AISI			High speed and continuous cutting	Medium, interrupted and continuous cutting	Low speed, interrupted and continuous cutting	
						Grade			N
						PC8110	PC3035	PC5300	N
vc (m/min)							fn (mm/rev)		
P	Non-alloy steel	C35	1035	1600	150	-	140	120	0.28
						-	170	150	0.18
						-	200	180	0.08
		C45	1045	1700	170	-	120	100	0.25
						-	150	120	0.15
	Alloy steel	42CrMo4	4140	1700	180	-	180	160	0.08
						-	120	100	0.25
						-	150	120	0.15
		-	4145	2050	350	-	180	160	0.08
						-	100	80	0.25
M	Austenite series	X5CrNi18-9 (X2CrNi19-11)	304	2000	180	-	150	140	0.08
						80	-	60	0.20
						130	-	120	0.15
		X5CrNiMo17-12-2	316	2000	180	170	-	160	0.06
						80	-	60	0.20
	Gray cast iron	250 (GG25)	No35B	1100	245	130	-	120	0.15
						170	-	160	0.06
						80	-	60	0.20
						100	-	80	0.28
						150	-	120	0.18
Ductile cast iron	450-10	80-55-06	1440	230	200	-	180	0.10	
					80	-	70	0.25	
					130	-	110	0.15	
					180	-	160	0.10	

Recommended cutting conditions _ S Chip breaker

Workpiece				Specific cutting force (N/mm ²)	Brinell hardness (HB)	Wear resistance ← • → Toughness		Grooving /parting
ISO	Workpiece materials	ISO (DIN)	AISI			High speed and continuous cutting	Low speed, interrupted and continuous cutting	
						Grade		S
						PC8110	PC5300	S
vc (m/min)							fn (mm/rev)	
M	Austenite series	X5CrNi18-9 (X2CrNi19-11)	304	2000	180	80	60	0.20
						150	130	0.15
						180	160	0.06
	X5CrNiMo17-12-2	316	2000	180	80	60	0.20	
					150	130	0.15	
					180	160	0.06	
S	Steel series	-	Inconel909	2400	200	65	55	0.15
						80	70	0.10
						95	85	0.05
	Ni series	15156-3	Inconel625	2650	250	45	35	0.15
						60	50	0.10
						75	65	0.05
		9723	Inconel718	2900	350	30	25	0.15
						40	35	0.10
						50	45	0.05
	Titanium alloy	-	B265 (ASTM)	1300	400	45	35	0.15
						60	50	0.10
						75	65	0.05
5832-11		Ti-6Al-4V	1400	950	35	25	0.15	
					50	40	0.10	
65	55	0.05						

Performance evaluation

N Chip breaker

Workpiece	Alloy steel (42CrMo4), Ø100		
Cutting conditions	vc(m/min) = 150, fn(mm/rev) = 0.15, ap(mm) = 15, wet		
Tools	Insert KSP300-020-N(PC5300)	Holder KSPB3026	

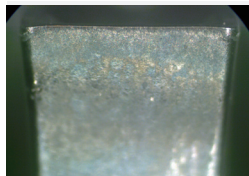

[Saw Man-X]



[Competitor]

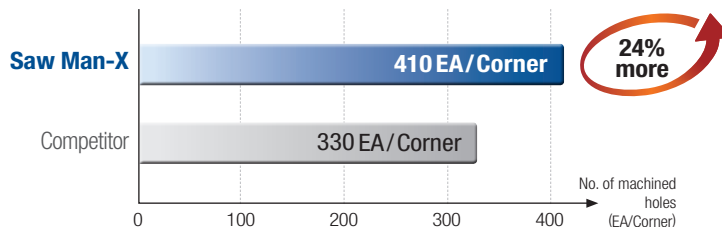

S Chip breaker

Workpiece	Stainless steel (X5CrNi18-9), Ø100		
Cutting conditions	vc(m/min) = 120, fn(mm/rev) = 0.15, ap(mm) = 7, wet		
Tools	Insert KSP300-02-S(PC5300)	Holder KSPB3026	



[Saw Man-X]



[Competitor]

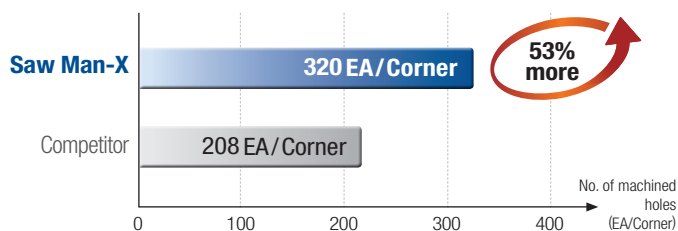

N Chip breaker (Lead angle type)

Workpiece	Alloy steel (42CrMo4), Ø100		
Cutting conditions	vc(m/min) = 120, fn(mm/rev) = 0.12, ap(mm) = 10 (Parting), wet		
Tools	Insert KSP300R-6D-N(PC5300)	Holder KSPB3026	



[Saw Man-X]

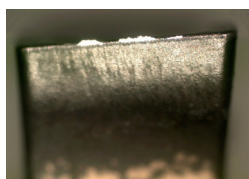

[Competitor]

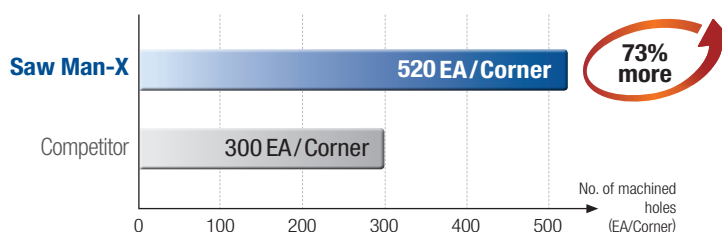

High pressure coolant

Workpiece	HRSA (9723), Ø50		
Cutting conditions	vc(m/min) = 50, fn(mm/rev) = 0.10, ap(mm) = 3, wet		
Tools	Insert KSP300-020-S(PC5300)	Holder KSPB3026-KHP	

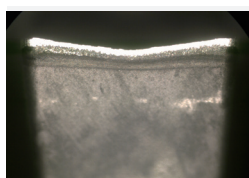

[70 bar internal spraying]

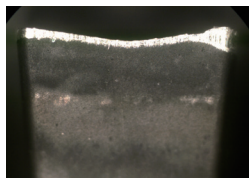

[External spraying]

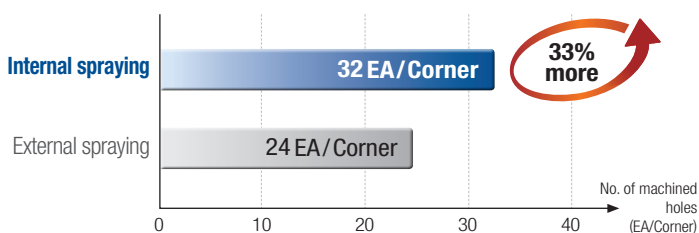

Tool selection guide

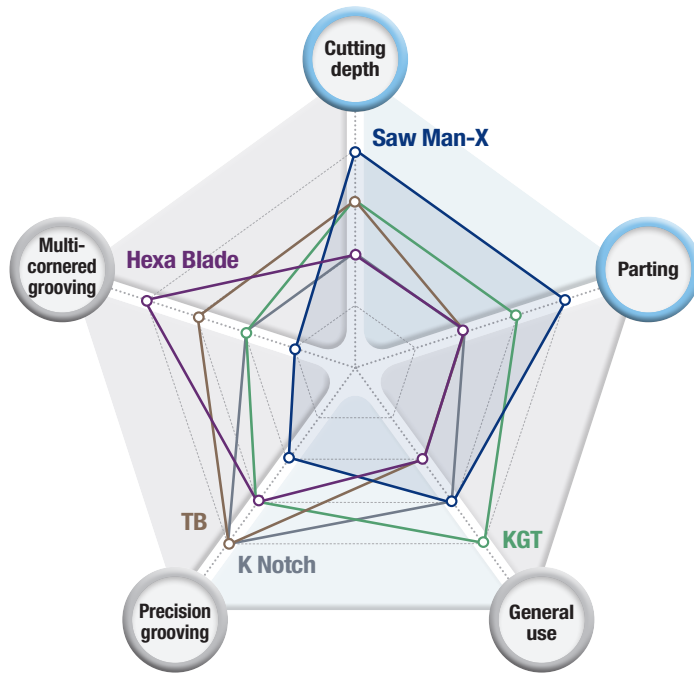

Saw Man-X ^{New}

- 1 cornered insert
- Optimal for interrupted and high feed parting
- Deep grooving



Hexa Blade ^{New}

- Precision typed and 6 cornered insert
- High cost efficiency
- Precision grooving and multi-cornered grooving

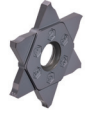

TB

- Precision typed and 3 cornered insert
- Optimal for automatic cutting
- Precision grooving

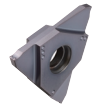

KGT

- 2 cornered insert
- Various applications
- For general use



K Notch

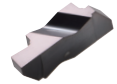

- Precision typed and 2 cornered insert
- Strong clamping system
- Precision grooving







Tools	Cutting depth	Parting	General use	Precision grooving	Multi-cornered grooving
Saw Man-X ^{New}	★★★★★	★★★★★	★★★	★★	★
Hexa Blade ^{New}	★★	★★	★★	★★★★	★★★★★
TB	★★★	★★	★★	★★★★★	★★★
KGT	★★★	★★★	★★★★★	★★★	★★
K Notch	★★	★★	★★★	★★★★★	★★

✓ Cutting width and cutting depth by tools

⊙: 1st recommendation ○: 2nd recommendation

Tools	Cutting width (mm)				No. of edges	Machining				Features
	2	4	6	8		External	Internal	Facing	Parting	
	5	10	20	60						
Cutting depth maximum (mm)										
Saw Man-X  <i>New</i>	2.0	6.0		60.0	1	○			⊙	<ul style="list-style-type: none"> • Various lead angles • Minimizing burr
Hexa Blde  <i>New</i>	1.78	4.0		5.0	6	⊙			○	<ul style="list-style-type: none"> • Precision type • High cost efficient cutting
TB 	1.25	6.0		6.5	3	⊙			○	<ul style="list-style-type: none"> • Precision type • Optimal for automated machining
KGT 	1.5	8.0		28.0	2	⊙	○	○	⊙	<ul style="list-style-type: none"> • For various kinds of cutting • For general cutting range
K Notch 	0.75	6.3		6.5	2	⊙				<ul style="list-style-type: none"> • Precision type • Strong clamping system

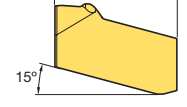
✓ Insert

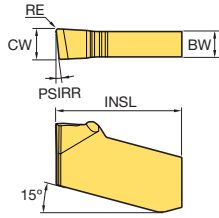
Picture	Designation	Coated			Dimensions (mm)					Geometries
		PC3035	PC5300	PC8110	CW	RE	INSL	PSIRR	BW	
	KSP 200-020-N	●	●	●	2.0	0.20	11.0	-	1.6	
	300-020-N	●	●	●	3.0	0.20	12.0	-	2.5	
	400-025-N	●	●	●	4.0	0.25	12.5	-	3.3	
	500-025-N	●	●	●	5.0	0.25	13.5	-	4.3	
	600-035-N	●	●	●	6.0	0.35	14.5	-	5.3	
 <i>New</i>	KSP 200-020-S		●	●	2.0	0.20	11.1	-	1.6	
	300-020-S		●	●	3.0	0.20	12.1	-	2.5	
	400-025-S		●	●	4.0	0.25	12.6	-	3.3	
	500-025-S		●	●	5.0	0.25	13.5	-	4.3	
	600-035-S		●	●	6.0	0.35	14.5	-	5.3	
 <i>New</i>	KSP 200R-6D-N	●	●	●	2.0	0.20	11.1	6°	1.6	
	200L-6D-N	●	●	●	2.0	0.20	11.1	6°	1.6	
	300R-6D-N	●	●	●	3.0	0.20	12.1	6°	2.5	
	300L-6D-N	●	●	●	3.0	0.20	12.1	6°	2.5	
	400R-4D-N	●	●	●	4.0	0.25	12.6	4°	3.3	
	400L-4D-N	●	●	●	4.0	0.25	12.6	4°	3.3	

●: Stock item

KSPB (Blade)

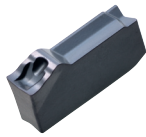

KSP

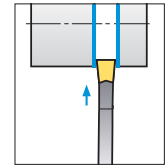
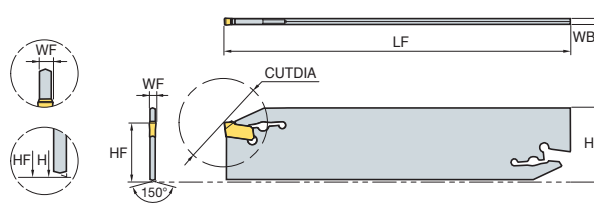

Designation		Stock	Cutting width	CUTDIA	H	WB	LF	HF	WF	Wrench
KSPB	2026	●	2	50	26	1.6	110	21	1.8	CW08
	2032	●	2	52	32	1.6	150	25	1.8	
	3026	●	3	72	26	2.4	110	21	2.7	
	3032	●	3	120	32	2.4	150	25	2.7	
	4026	●	4	72	26	3.2	110	21	3.6	
	4032	●	4	120	32	3.2	150	25	3.6	
	5026		5	80	26	4.0	110	21	4.5	CW10
	5032	●	5	120	32	4.0	150	25	4.5	
	6026		6	120	26	5.2	110	21	5.6	
	6032	●	6	120	32	5.2	150	25	5.6	

(mm)

●: Stock item

SMBB (Block)



KSPB□□□□
 SPB□□□(-S)
 KGTB□□□□(S)

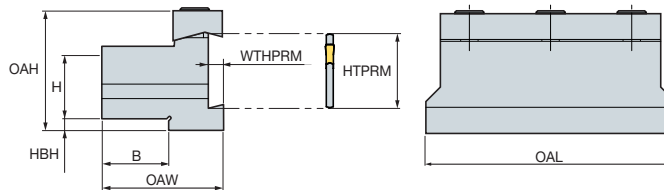

Designation		Stock	H	B	HTPRM	OAL	OAH	HBH	OAW	WTHPRM	Screw	Wrench
SMBB	1626	●	16	12	26	86	43	13	30	5.3	3-M6	HW50L
	2026	●	20	19	26	86	43	9	38	5.3	3-M6	
	2032	●	20	19	32	100	50	13	38	5.3	4-M6	
	2526	●	25	23	26	86	43	4	42	5.3	4-M6	
	2532	●	25	23	32	110	50	8	42	5.3	4-M6	
	3232	●	32	30	32	110	54	5	48	5.3	4-M6	

(mm)

●: Stock item

KSPH (Shank)

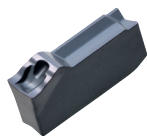

KSP

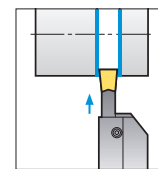
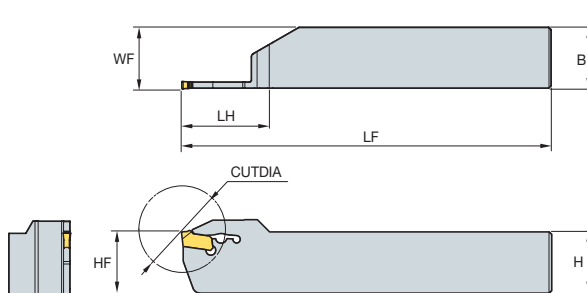

• R type insert

(mm)

Designation	Stock		Cutting width	H=(HF)	B	LH	LF	CUTDIA	WF	Wrench
	R	L								
KSPH	216R/L		2	16	16	31	100	46	16.2	CW08
	220R/L		2	20	20	32	120	48	20.2	
	225R/L	●	2	25	25	33	150	50	25.2	
	316R/L		3	16	16	34	100	52	16.2	
	320R/L	●	3	20	20	35	120	54	20.2	
	325R/L	●	3	25	25	36	150	56	25.2	
	420R/L	●	4	20	20	40	120	64	20.4	
	425R/L	●	4	25	25	41	150	66	25.4	
520R/L		5	20	20	45	120	74	20.4	CW10	
525R/L	●	5	25	25	46	150	76	25.4		
625R/L	●	6	25	25	46	150	76	25.4		

●: Stock item

KSPB (Blade) New!

High pressure coolant



KSP

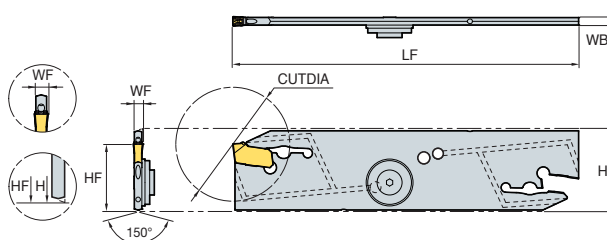

Recommended pressure: 70 bar

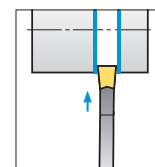

(mm)

Designation	Stock	Cutting width	CUT DIA	H	WB	LF	HF	WF	Wrench	Copper washer	Sealing plate	Sealing screw	
													KSPB
	4026-KHP	●	4	72	26	3.4	110	21	3.7				

●: Stock item

SMBB (Block) New!

High pressure coolant

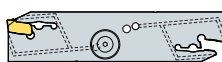

KSPB□□□□-KHP

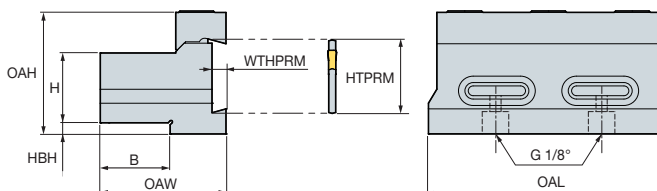







Recommended pressure: 70 bar

(mm)

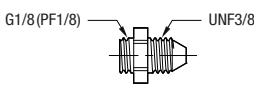

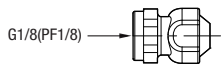
Designation	Stock	H	B	HTPRM	OAL	OAH	HBH	OAW	WTHPRM	Screw	Wrench	O-ring	
													SMBB
	2526-KHP	●	25	25	26	86	43.5	4	45	5			

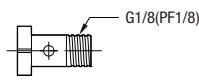
●: Stock item

Connecting parts

Parts	Designation	Shape of parts	
Adaptor	HPA3/8UNF1/8PF		
Blank	HPB1/8PF		
Banjo screw	HPZ1/8PF		
Copper washer	HPW1/8PF		

High pressure hose

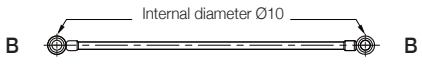
The shape of the high pressure hose		Length	Standard S	Standard B
Straight to straight (HPH3/8UNF)		200 mm	UNF3/8	-
		250 mm		
Straight to banjo (HPH3/8UNF1/8PF)		200 mm	UNF3/8	Internal diameter Ø10
		250 mm		
Banjo to banjo (HPH1/8PF)		200 mm	-	Internal diameter Ø10
		250 mm		

Notice

- Use a proper spanner for clamping up to the specs.
- Be careful of coolant injection by the residual pressure while using high pressure coolant.
- Clamp the parts completely before usage.
- Clean the turning machine before clamping.
- The O-ring is included in the parts. Don't have to purchase it separately.

⚠ For the safe metalcutting

- Use safety supplies such as protective gloves to prevent possible injury while touching the edge of tools.
- Use safety glasses or safety cover to hedge possible dangers. Inappropriate usage or excessive cutting condition may lead tool's breakage or even the fragment's scattering.
- Clamp the workpiece tightly enough to prevent its movement while its machining.
- Properly manage the tool change phase because the inordinately used tool can be easily broken under the excessive cutting load or severe wear, and it may threat the operator's safety.
- Use safety cover because chips evacuated during cutting are hot and sharp and may cause burns and cuts. To remove chips safely, stop machining, put on protective gloves, and use a hook or other tools.
- Prepare for fire prevention measures as the use of the non-water soluble cutting oil may cause fire.
- Use safety cover and other safety supplies because the spare parts or the inserts can be pulled out due to centrifugal force while high speed machining.



Head Office: Holystar B/D, 326, Seocho-daero, Seocho-gu, Seoul, 06633, Republic of Korea
Tel: +82-2-522-3181 Fax: +82-2-522-3184, +82-2-3474-4744 Web: www.korloy.com E-mail: sales.khq@korloy.com

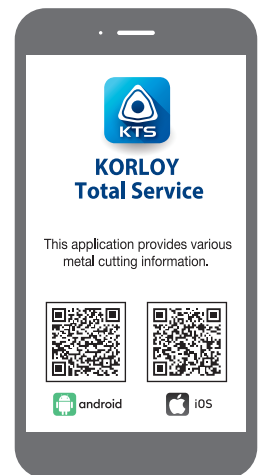

KORLOY AMERICA

620 Maple Avenue, Torrance, CA 90503, USA
Tel: +1-310-782-3800 Toll Free: +1-888-711-0001 Fax: +1-310-782-3885
E-mail: sales.kai@korloy.com

KORLOY INDIA

Plot No. 415, Sector 8, IMT Manesar, Gurgaon 122051, Haryana, India
Tel: +91-124-4391790 Fax: +91-124-4050032
E-mail: sales.kip@korloy.com

KORLOY TURKIYE

Serifali Mahallesi, Burhan Sokak NO: 34
Dudullu OSB/Umraniye/Istanbul, 34775, Turkey
Tel: +90-216-415-8874 E-mail: sales.ktl@korloy.com

KORLOY RUSSIA

Krasivy Dom office No. 305, Bld. 5, Novovladykinskiy proezd 8, 127106,
Moscow, Russia
Tel: +7-495-280-1458 Fax: +7-495-280-1459 E-mail: sales.krc@korloy.com

KORLOY FACTORY INDIA

Plot No. 415, Sector 8, IMT Manesar, Gurgaon 122051, Haryana, India
Tel: +91-124-4391790 Fax: +91-124-4050032
E-mail: pro.kim@korloy.com

KORLOY EUROPE

Gablonzer Str. 25-27, 61440 Oberursel, Germany
Tel: +49-6171-277-83-0 Fax: +49-6171-277-83-59
E-mail: sales.keg@korloy.com

KORLOY BRASIL

Av. Aruana 280, conj.12, WLC, Alphaville, Barueri,
CEP06460-010, SP, Brasil
Tel: +55-11-4193-3810 E-mail: sales.kbl@korloy.com

KORLOY CHILE

Av. Providencia 1650, Office 1009, 7500027
Providencia-Santiago, Chile
Tel: +56-229-295-490 E-mail: sales.kcs@korloy.com

KORLOY MEXICO

Calle R. M. Clemencia Borja Taboada 522, Jurica Acueducto,
76230 Juriquilla, Qro., Mexico
Tel: +52-442-673-7388 E-mail: sales.kml@korloy.com

