

ТРЦР

Tangen-Pro series

Tangential Double-Sided 4-Corner Shoulder Milling Tool

- High depth-of-cut (up to 12mm) shoulder milling by high helix chip-breaking double-sided inserts
- Enhanced productivity through strong clamping force of the tangential type and multi-insert application

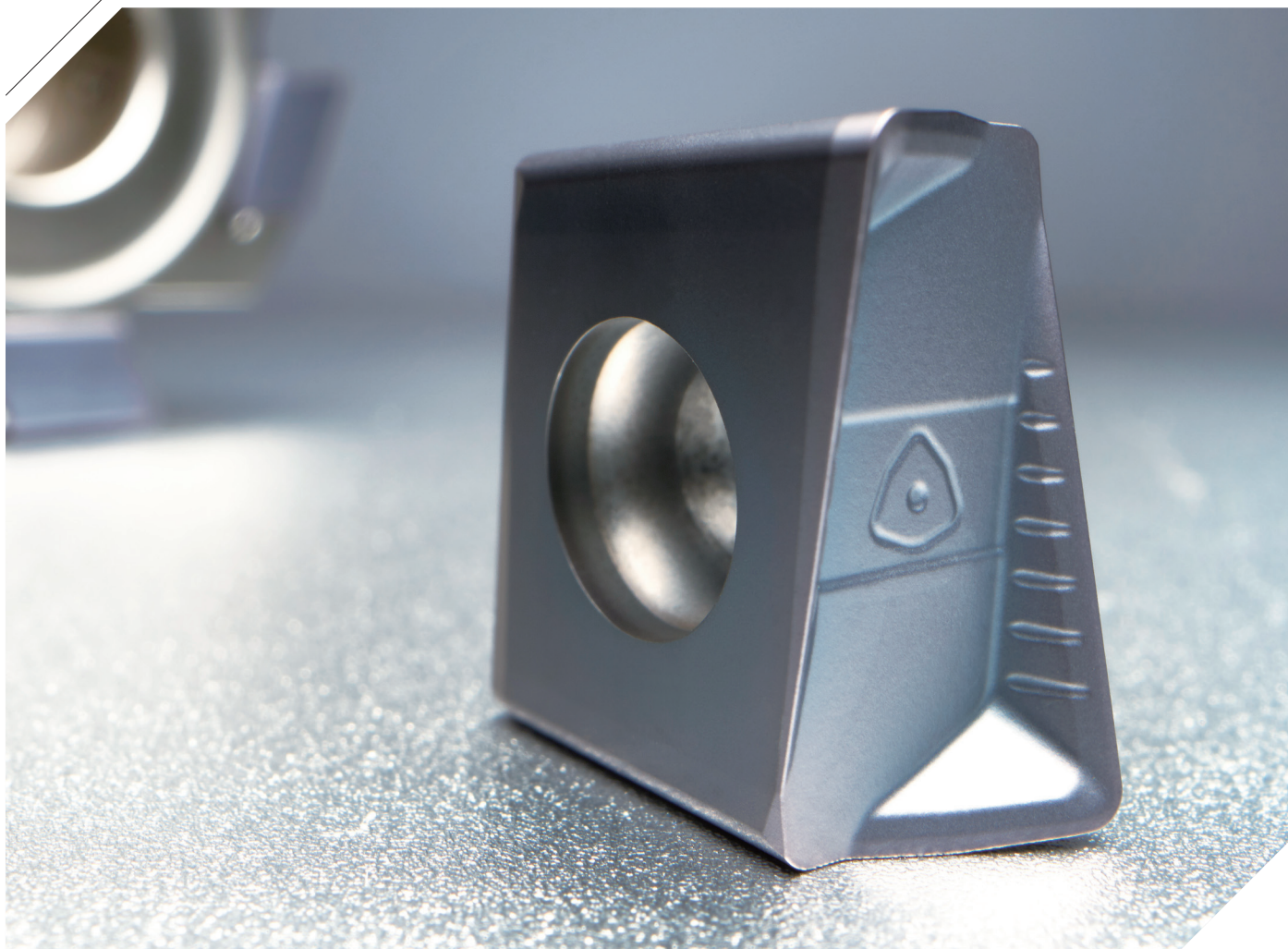

TP4P (Tangen-Pro series)

Based on KORLOY's differentiated manufacturing technology, we have launched Tangen-Pro TP4P, a tangential double-sided and 4-corner shoulder milling cutter.

Generally, the tangential type makes it easier to secure chip pocket space compared to the radial type, offers excellent clamping stability, and enables multi-insert clamping for the same cutting diameter, resulting in improved productivity through high table feed rates.

TP4P is equipped with the advantages of the tangential type but also features a chip-breaking edge design that effectively reduces vibration and cutting forces, providing superior machinability. Its optimized wide base and side clamping structure maintain strong clamping force even in high-speed/high-feed machining, ensuring stable machining.

In addition, the combination with KORLOY's various specialized grades makes it applicable not only to steel and cast iron but also to various workpieces such as stainless steel and titanium alloys. It demonstrates outstanding performance, especially in roughing.

Thus, TP4P provides over 30% productivity improvement compared to the radial type through high speed / high feed machining by increasing table feed, stable clamping, and a chip-breaking edge.

» **Excellent cutting performance**

- Application of High Helix and Chip-breaking Chip Breakers

» **Various holder lineup**

- Enhanced adaptability through a diverse lineup of holders

» **Stable clamping**

- Ensures wide clamping side

» **Excellent Economical Efficiency**

- Up to 4 usable corners due to double-sided design

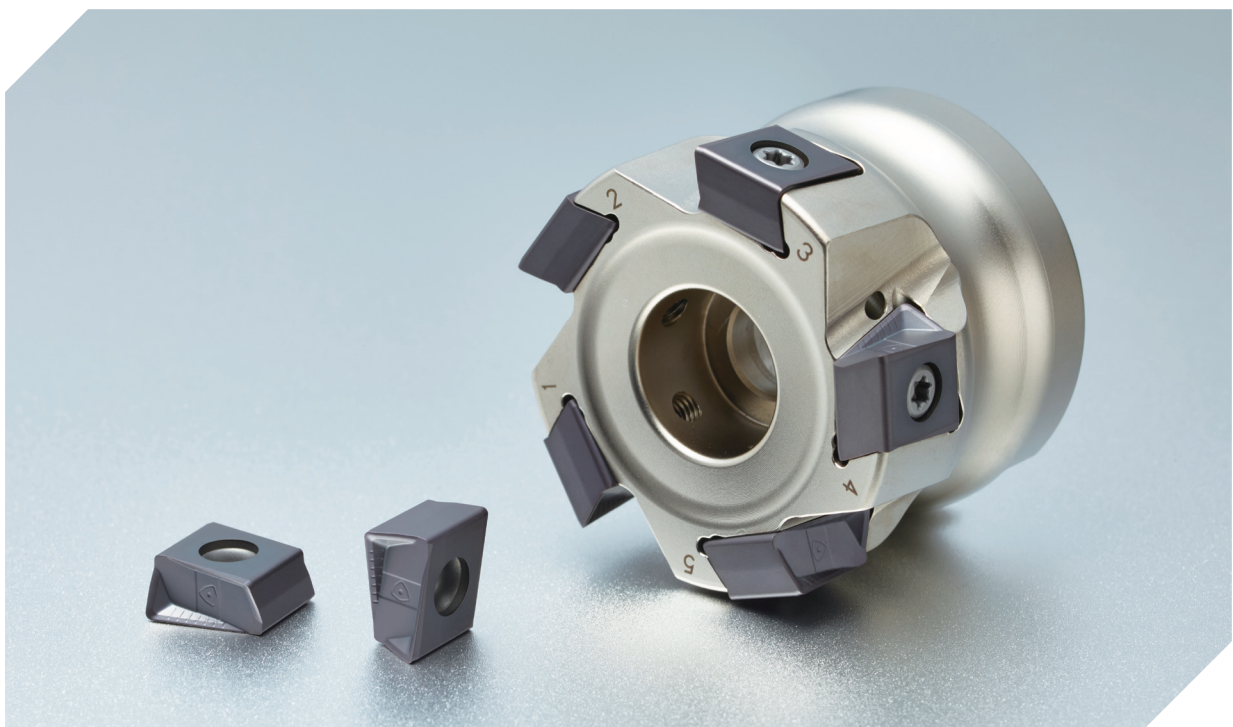

Code system

Cutter type (Single-edge)

TP4	P	C	M	063	R	-	22	-	6	-	LN13
TP4 (Tangen-Pro)	KAPR P: 90°	Type C: Cutter	Arbor M: Metric A: Inch None: Asia	Machining diameter 063: Ø63 mm	Oil hole & hand R: With oil hole, right-handed NR: Without oil hole, right-handed			Internal diameter 22: Ø22 mm	No. of tooth 6: 6 tooth		Available insert LN13: LNGX13

Cutter type (Multi-edge)

TP4	P	C	M	050	M	-	22	-	4F	-	47	LN13
TP4 (Tangen-Pro)	KAPR P: 90°	Type C: Cutter	Arbor M: Metric A: Inch None: Asia	Machining diameter 050: Ø50 mm	Oil hole & hand M: With oil hole, Multi-edge NM: Without oil hole, Multi-edge			Internal diameter 22: Ø22 mm	No. of flute 4F: 4 Flute		APMX 47: 47 mm	Available insert LN13: LNGX13

Shank type

TP4	P	S	032	R	-	3	W	32	-	110	-	LN13
TP4 (Tangen-Pro)	KAPR P: 90°	Type S: Shank	Machining diameter 032: Ø32 mm	Oil hole & hand R: With oil hole, right-handed NR: Without oil hole, right-handed			No. of tooth 3: 3 tooth	Shank diameter 32: Ø32 mm	Shank type W: Weldon C: Cylinder		Overall length 110: 110 mm	Available insert LN13: LNGX13

Features

Heat Dispersion

Chip Breaker Structure

- Installation of multiple dimples
- Prevents thermal cracks and Increases tool life

KORLOY Identity symbol mark

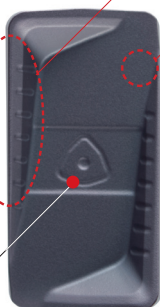

Excellent Clamping Stability

- Ensures a large clamping surface area

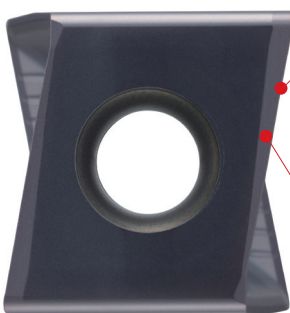

High Depth-of-Cut Structure and Optimized Perpendicularity

- APMX 12 mm
- Perpendicularity within 30 μm

Reinforced Edge Geometry



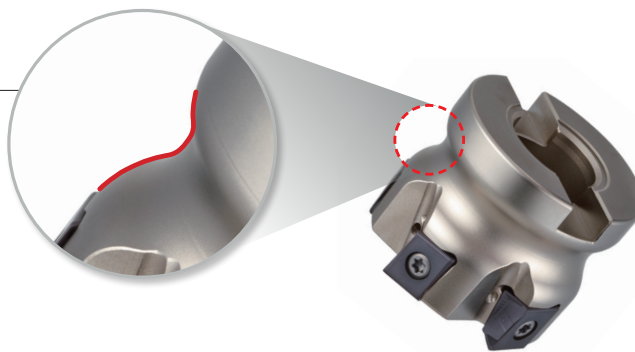

- Double Negative-Positive Edge Structure
- Improves chipping resistance and Prevents from sudden breakage

Streamlined holder Structure

- Smooth chip evacuation

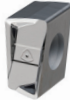
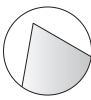

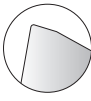
Application and features of chip breakers

Chip breaker		Cutting edge	Application	Feature
MA			For Aluminum	<ul style="list-style-type: none"> Sharp cutting edges for excellent cutting performance in aluminum machining Buffed surface for excellent chip flow and welding resistance
ML			For HRSA and Titanium	<ul style="list-style-type: none"> Guarantees high quality of performance from applying suitable for low cutting resistance chip breaker for HRSA cutting and high hardness cutting edge
MM			For general cutting	<ul style="list-style-type: none"> Suitable for general cutting range from design structure for general high feed cutting

Recommended grade and cutting edge

Recommended grade and cutting edge (●: 1 st recommendation)									
P		M		K		S		N	
C/B	Grade	C/B	Grade	C/B	Grade	C/B	Grade	C/B	Grade
● MM ○ ML	● PC3700 ○ PC5300	● ML	● PC9540 ○ PC5300	● ML ○ MM	● PC6100 ○ PC5300	● ML	● UNC840 ○ UPC845 ○ PC5300	● MA	● H05

Recommended cutting conditions

Workpiece				Specific cutting force (N/mm ²)	Brinell hardness (HB)	Grade	Chip breaker		Grade	Chip breaker		MM/ML APMX(mm)
ISO	Workpiece material	ISO	AISI			PC3700	MM	ML	PC5300	MM	ML	
						vc(m/min)	fz(mm/t)		vc(m/min)	fz(mm/t)		
P	Non-ferrous alloy steel Mn < 1.65	C25	1025	1500	125	230	0.3	0.3	210	0.3	0.3	12
						305	0.2	0.2	280	0.2	0.2	
						380	0.1	0.1	350	0.1	0.1	
		C45	1045	1700	190	210	0.3	0.3	190	0.3	0.3	
						280	0.2	0.2	255	0.2	0.2	
						350	0.1	0.1	320	0.1	0.1	
	Low alloy steel ≤ 5%	42CrMo4	4140	1700	175	160	0.3	0.3	150	0.3	0.3	
						215	0.2	0.2	195	0.2	0.2	
						270	0.1	0.1	240	0.1	0.1	
						120	0.3	0.3	110	0.3	0.3	
High alloy steel > 5%	X40CrMoV5-1	D2, H13	1950	200	160	0.2	0.2	150	0.2	0.2		
					200	0.1	0.1	190	0.1	0.1		

Workpiece				Specific cutting force (N/mm ²)	Brinell hardness (HB)	Grade	Chip breaker		Grade	Chip breaker		MM/ML APMX(mm)
ISO	Workpiece material	ISO	AISI			PC5535	MM	ML	PC5300	MM	ML	
						vc(m/min)	fz(mm/t)		vc(m/min)	fz(mm/t)		
M	Ferritic/ martensitic	X6CrAl13 X6Cr17	405,430	1800	200	120	0.2	0.2	130	0.2	0.2	12
						160	0.15	0.15	170	0.15	0.15	
						200	0.1	0.1	210	0.1	0.1	
		X12CrS13 X6CrMo17-1	416,434	2850	330	110	0.2	0.2	120	0.2	0.2	
						150	0.15	0.15	160	0.15	0.15	
						190	0.1	0.1	200	0.1	0.1	
		X12Cr13	403, 410	2350	330	110	0.2	0.2	120	0.2	0.2	
						150	0.15	0.15	160	0.15	0.15	
		Austenitic	X5CrNi18-9 X2CrNi18-9 X5CrNiMo17-12-2 XCrNiMo17-12-3	304, 316	2000	180	190	0.1	0.1	200	0.1	
	100						0.2	0.2	105	0.2	0.2	
	135						0.15	0.15	140	0.15	0.15	
	Austenitic/ ferritic (Duplex)	-	S31803, S32750	2450	260	170	0.1	0.1	175	0.1	0.1	
						75	0.2	0.2	80	0.2	0.2	
						105	0.15	0.15	110	0.15	0.15	

Recommended cutting conditions

Workpiece				Specific cutting force (N/mm ²)	Brinell hardness (HB)	Grade	Chip breaker		Grade	Chip breaker		MM/ML
ISO	Workpiece material	ISO	AISI			PC6100	MM	ML	PC5535	MM	ML	APMX(mm)
						vc(m/min)	fz(mm/t)		vc(m/min)	fz(mm/t)		
K	Gray cast iron	200	No 30 B	900	180	180	0.3	0.3	150	0.3	0.3	12
						240	0.2	0.2	200	0.2	0.2	
						300	0.1	0.1	250	0.1	0.1	
	Nodular graphite cast iron	500-7	80-55-06	870	155	120	0.3	0.3	100	0.3	0.3	
						160	0.2	0.2	150	0.2	0.2	
						200	0.1	0.1	200	0.1	0.1	

Workpiece				Specific cutting force (N/mm ²)	Brinell hardness (HB)	Grade	Chip breaker		MM/ML	
ISO	Workpiece material	ISO	AISI			UPC830	MM	ML	APMX(mm)	
						vc(m/min)	fz(mm/t)			
S	Nickel based	15156-3	15156-3	2650	250	30	0.2	0.2	12	
						40	0.15	0.15		
		9723	9723	3000	320	50	0.1	0.1		
						35	0.15	0.15		
	Cobalt based alloy	Stellite	Stellite	3000 ~3100	300 ~320	25	0.2	0.2		
						35	0.15	0.15		
		Titanium alloy steel	5832-3	ASTM B265	1400	320	45	0.1		0.1
							55	0.15		0.15
							45	0.2		0.2
							65	0.1		0.1

Workpiece				Specific cutting force (N/mm ²)	Brinell hardness (HB)	Grade	Chip breaker	MA
ISO	Workpiece material	ISO	AISI			H05	MA	APMX(mm)
						vc(m/min)	fz(mm/t)	
N	Aluminum	AlMg1SiCu	6061	125 ~310	30 ~65	500	0.25	12
						700	0.15	
						1,000	0.05	
	AlZn5.5MgCu	7075	230 ~570	60 ~150	500	0.25		
					700	0.15		
					1,000	0.05		

Performance evaluation

Chipping resistance

Workpiece Titanium alloy (5832-3), 100 (L) × 100 (W) × 100 (H), Steel rectangular tube

Cutting condition vc (m/min) = 50, fz (mm/t) = 0.15, ap (mm) = 10, ae (mm) = 5, wet

Tool **Insert** LNGX130608PNR-ML (PC5300) **Holder** TP4PCM050R-22-5-LN13



Performance evaluation

Wear resistance

Workpiece Alloy steel (SCM440), 300 (L) × 200 (W) × 100 (H), Steel rectangular tube

Cutting condition vc (m/min) = 200, fz (mm/t) = 0.15, ap (mm) = 7, ae (mm) = 10, dry

Tool **Insert** LNGX130608PNR-MM (PC5300) **Holder** TP4PCM050R-22-5-LN13



Tool selection guide

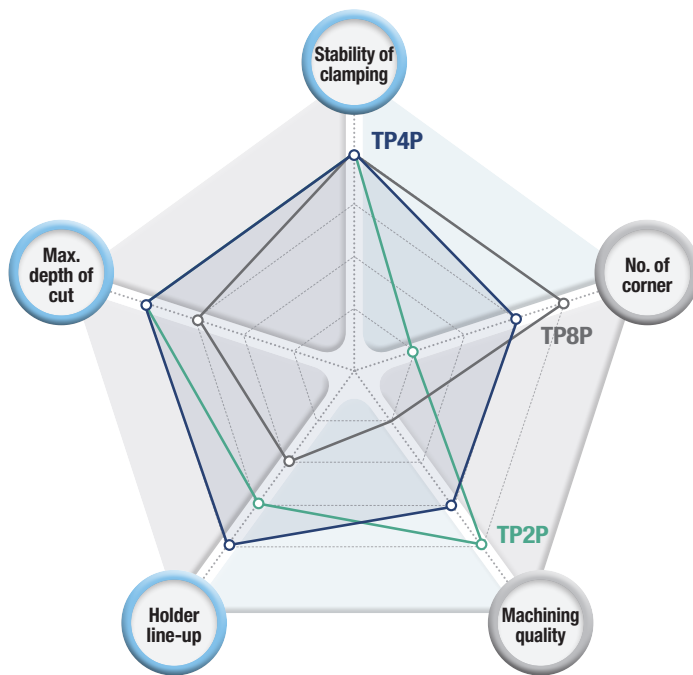

TP4P *New!*

- Standard Type
- Excellent machinability
- High clamping stability



TP8P

- Maximum no. of corners
- Highly stable clamping

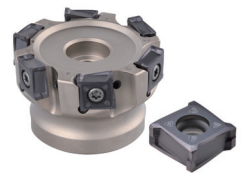

TP2P

- Highly stable clamping
- Good cutting performance
- Excellent surface finish



Tools	Stability of clamping	No. of corner	Machining quality	Holder line-up	Max. depth of cut
TP4P <i>New!</i>	★★★★★	★★★	★★★	★★★★★	★★★★★
TP8P	★★★★★	★★★★★	★	★★	★★★
TP2P	★★★★★	★	★★★★★	★★★	★★★★★

✓ Ramping and helical cutting

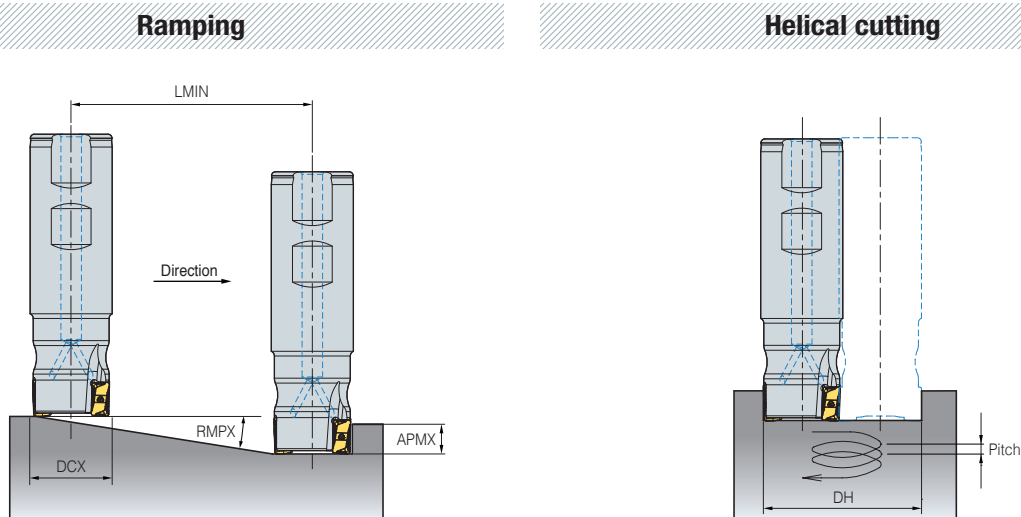

(mm)

Designation	DCX	APMX	Ramping		Helical cutting			
			RMPX(°)	LMIN	Min diameter (DHmin)	Max pitch	Max diameter (DHmax)	Max pitch
LNGX13	25	12	1.42	484	42	1.31	48	1.82
	32	12	0.9	765	56	1.18	62	1.5
	40	12	0.62	1,104	72	1.09	78	1.31
	50	12	0.46	1,488	92	1.06	98	1.23
	63	12	0.36	1,926	118	1.07	124	1.2
	80	12	0.27	2,528	152	1.07	158	1.17
	100	12	0.21	3,274	192	1.06	198	1.13
	125	12	0.17	4,068	242	1.08	248	1.14

- When ramping and helical milling, table feed, vf (ipm) should be lower than 70% of the recommended cutting conditions.
- When helical milling, Max. pitch, DHmax should be lower than max. depth of cut, APMX.
- When ramping, the depth of cut should be lower than max. depth of cut, APMX.

- $L_{min} = APMX / \tan(RMPX)$ (mm)
- **Lmin**: Min. length of ramping
- **APMX**: depth of cut Maximum
- **RMPX**: Max. rake angle in ramping

✓ Inserts

Picture	Designation	Coated						Uncoated	Dimension (mm)					Geometry
		PC3700	PC6100	PC5300	PC5535	PC5400	UPC830	H05	INSL	S	W1	RE	APMX	
	LNGX 130608PNR-MA							●	13.35	13.011	6.8	0.8	12	
	LNGX 130608PNR-ML	●	●	●	●	●	●		13.35	13.011	6.8	0.8	12	
	LNGX 130608PNR-MM	●	●	●	●	●	●		13.35	13.011	6.8	0.8	12	

●: Stock item

TP4PC(M)-LN13 (Single-edge)



KAPR
90°

• GAMP: -6°
• GAMF: -19° ~ -17°

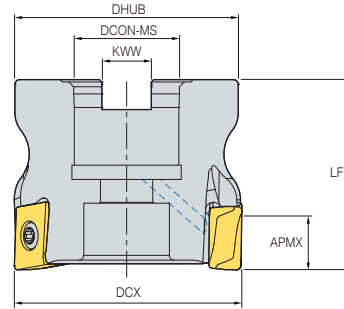
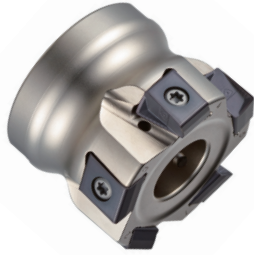

(mm)

	Designation	Stock	DCX	CICT	DCON-MS	DHUB	LF	KWW	APMX
TP4PCM	040R-16-4-LN13	●	40	4	16	38	40	8.4	12
	040R-16-5-LN13	●	40	5	16	38	40	8.4	12
	050R-22-5-LN13	●	50	5	22	47	40	10.4	12
	050R-22-6-LN13	●	50	6	22	47	40	10.4	12
	063R-22-6-LN13	●	63	6	22	55	40	10.4	12
	063R-22-8-LN13	●	63	8	22	55	40	10.4	12
	080R-27-7-LN13	●	80	7	27	70	50	12.4	12
	080R-27-10-LN13	●	80	10	27	70	50	12.4	12
	100R-32-8-LN13	●	100	8	32	78	50	14.4	12
	100R-32-13-LN13	●	100	13	32	78	50	14.4	12
	125R-40-9-LN13	●	125	9	40	82	63	16.4	12
	125R-40-17-LN13	●	125	17	40	82	63	16.4	12
TP4PC	080R-25.4-7-LN13	●	80	7	25.4	70	50	9.5	12
	080R-25.4-10-LN13	●	80	10	25.4	70	50	9.5	12
	100R-31.75-8-LN13	●	100	8	31.75	78	63	12.7	12
	100R-31.75-13-LN13	●	100	13	31.75	78	63	12.7	12
	125R-38.1-9-LN13	●	125	9	38.1	82	63	15.9	12
	125R-38.1-17-LN13	●	125	17	38.1	82	63	15.9	12

●: Stock item

Available inserts

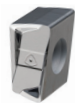

LNGX-MA



LNGX-ML



LNGX-MM

Designation	Coated						Uncoated
	PC3700	PC6100	PC5300	PC5535	PC5400	UPC830	H05
LNGX 130608PNR-MA							●
130608PNR-ML	●	●	●	●	●	●	
130608PNR-MM	●	●	●	●	●	●	

●: Stock item

Parts

Parts	Screw	Wrench
Specification		
Ø40	FTKA0410	TW15S
Ø50 ~ Ø125	FTKA0412B	TW15S

TP4PCM-LN13 (Multi-edge)



KAPR 90°
 • GAMP: -6°
 • GAMF: -21° ~ -17°

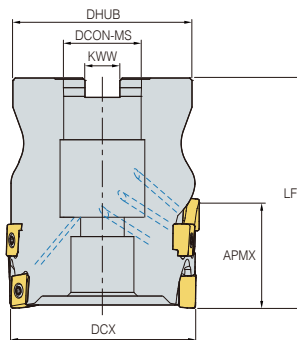
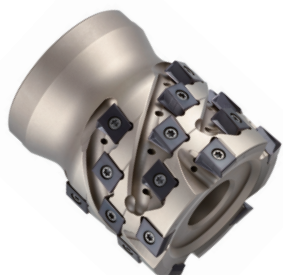

(mm)

Designation	Stock	DCX	CICT	ZEFF	DCON-MS	DHUB	LF	KWW	APMX
TP4PCM 050M-22-3F32-LN13		50	9	3	22	48	56	10.4	32
050M-22-4F43-LN13		50	16	4	22	48	68	10.4	43
063M-27-5F53-LN13		63	25	5	27	58	80	12.4	53
080M-32-5F64-LN13		80	30	5	32	74	111	14.4	64

●: Stock item

Available inserts



Designation	Coated						Uncoated
	PC3700	PC6100	PC5300	PC5535	PC5400	UPC830	H05
LNGX 130608PNR-MA							●
130608PNR-ML	●	●	●	●	●	●	
130608PNR-MM	●	●	●	●	●	●	

●: Stock item

Parts

Parts	Screw	Wrench
Specification		
Ø50 ~ Ø80	FTKA0412B	TW15S



TP4PS-LN13



KAPR
90°

- GAMP: -6°
- GAMF: -32° ~ -21°

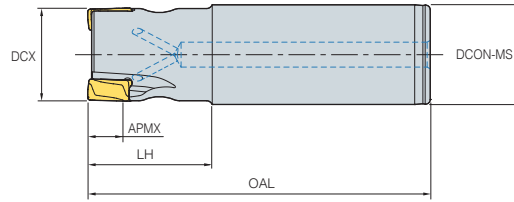

(mm)

	Designation	Stock	DCX	CICT	DCON-MS	OAL	LH	APMX
TP4PS	025R-2C25-120-LN13	●	25	2	25	120	35	12
	025R-2W25-95-LN13	●	25	2	25	95	35	12
	032R-2C32-250-LN13	●	32	2	32	250	50	12
	032R-2W32-110-LN13	●	32	2	32	110	40	12
	032R-3C32-250-LN13	●	32	3	32	250	50	12
	032R-3W32-110-LN13	●	32	3	32	110	40	12
	040R-3C32-250-LN13	●	40	3	32	250	50	12
	040R-3W32-115-LN13	●	40	3	32	115	40	12
	040R-4C32-250-LN13	●	40	4	32	250	50	12
	040R-4W32-115-LN13	●	40	4	32	115	40	12

●: Stock item

Available inserts

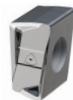

LNGX-MA



LNGX-ML



LNGX-MM

Designation	Coated						Uncoated
	PC3700	PC6100	PC5300	PC5535	PC5400	UPC830	H05
LNGX 130608PNR-MA							●
130608PNR-ML	●	●	●	●	●	●	
130608PNR-MM	●	●	●	●	●	●	

●: Stock item

Parts

Parts	Screw	Wrench
Specification		
Ø25	FTKA0410	TW15S
Ø32 ~ Ø40	FTKA0412B	TW15S

⚠ For the safe metalcutting

- Use safety supplies such as protective gloves to prevent possible injury while touching the edge of tools.
- Use safety glasses or safety cover to hedge possible dangers. Inappropriate usage or excessive cutting condition may lead tool's breakage or even the fragment's scattering.
- Clamp the workpiece tightly enough to prevent its movement while its machining.
- Properly manage the tool change phase because the inordinately used tool can be easily broken under the excessive cutting load or severe wear, and it may threat the operator's safety.
- Use safety cover because chips evacuated during cutting are hot and sharp and may cause burns and cuts. To remove chips safely, stop machining, put on protective gloves, and use a hook or other tools.
- Prepare for fire prevention measures as the use of the non-water soluble cutting oil may cause fire.
- Use safety cover and other safety supplies because the spare parts or the tools can be pulled out due to centrifugal force while high speed machining.



Head Office: Holystar B/D, 326, Seocho-daero, Seocho-gu, Seoul, 06633, Republic of Korea
Tel: +82-2-522-3181 Fax: +82-2-522-3184, +82-2-3474-4744 Web: www.korloy.com E-mail: sales.khq@korloy.com

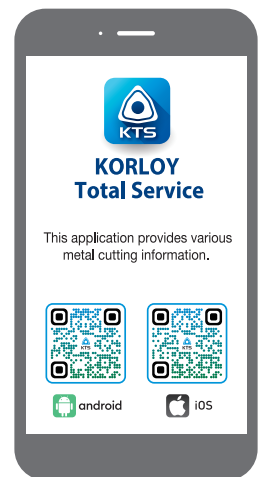

KORLOY AMERICA

620 Maple Avenue, Torrance, CA 90503, USA
Tel : +1-310-782-3800 / +1-888-711-0001 Fax : +1-310-782-3885
E-mail : sales.kai@korloy.com

KORLOY INDIA

Plot No. 415, Sector 8, IMT Manesar, Gurgaon 122051, Haryana, India
Tel : +91-124-4391790 Fax : +91-124-4050032
E-mail : sales.kip@korloy.com

KORLOY TURKIYE

Ziya Gokalp, Mah. Seyit Onbasi Cad. No:36, 3 Kat,
iC Kapi No : 5 Basaksehir/Istanbul, Turkiye
Tel : +90-212-813-8874 E-mail : sales.ktl@korloy.com

KORLOY RUSSIA

115280, Moscow, vn.ter.g. municipal district Danilovsky,
street Masterkova, house 4, premises 1/2
Tel : +7-495-280-1458 Fax : +7-495-280-1459 E-mail : sales.krc@korloy.com

KORLOY UK

13 Approach Rd, Raynes Park, London SW20 8BA, United Kingdom
E-mail : sales.kul@korloy.com

KORLOY EUROPE

Gablonzer Str. 25-27, 61440 Oberursel, Germany
Tel : +49-6171-27783-0 Fax : +49-6171-27783-59
E-mail : sales.keg@korloy.com

KORLOY BRASIL

Av. Aruana 280, conj.12, WLC, Alphaville, Barueri, CEP06460-010, SP, Brasil
Tel : +55-11-4193-3810 Fax : +55-11-4193-5837
E-mail : sales.kbl@korloy.com

KORLOY CHILE

Av. Providencia 1650, Office 1009, 7500027
Providencia-Santiago, Chile
Tel : +56-229-295-490 E-mail : sales.kcs@korloy.com

KORLOY MEXICO

Avenida de las Ciencias, No. 3015, Interior 406, Juriquilla Santa Fe,
C.P.76230 Querétaro, Mexico
Tel : +52-442-193-3600 E-mail : sales.kml@korloy.com

KORLOY FACTORY INDIA

Plot NO. 415, Sector 8, IMT Manesar, Gurgaon 122051, Haryana, India
Tel : +91-124-4391790 Fax : +91-124-4050032
E-mail : pro.kim@korloy.com

